

SimPowerSystems

For Use with Simulink®

Hydro-Québec

TransÉnergie Technologies

- Modeling
- Simulation
- Implementation

How to Contact The MathWorks:



www.mathworks.com
comp.soft-sys.matlab
www.mathworks.com/contact_TS.html

Web
Newsgroup
Technical support



suggest@mathworks.com
bugs@mathworks.com
doc@mathworks.com
service@mathworks.com
info@mathworks.com

Product enhancement suggestions
Bug reports
Documentation error reports
Order status, license renewals, passcodes
Sales, pricing, and general information



508-647-7000 (Phone)



508-647-7001 (Fax)



The MathWorks, Inc.
3 Apple Hill Drive
Natick, MA 01760-2098

For contact information about worldwide offices, see the MathWorks Web site.

SimPowerSystems User's Guide

© COPYRIGHT 1998-2006 TransÉnergie Technologies Inc., under sublicense from Hydro-Québec, and The MathWorks, Inc.

The software described in this document is furnished under a license agreement. The software may be used or copied only under the terms of the license agreement. No part of this manual may be photocopied or reproduced in any form without prior written consent from The MathWorks, Inc.

FEDERAL ACQUISITION: This provision applies to all acquisitions of the Program and Documentation by, for, or through the federal government of the United States. By accepting delivery of the Program or Documentation, the government hereby agrees that this software or documentation qualifies as commercial computer software or commercial computer software documentation as such terms are used or defined in FAR 12.212, DFARS Part 227.72, and DFARS 252.227-7014. Accordingly, the terms and conditions of this Agreement and only those rights specified in this Agreement, shall pertain to and govern the use, modification, reproduction, release, performance, display, and disclosure of the Program and Documentation by the federal government (or other entity acquiring for or through the federal government) and shall supersede any conflicting contractual terms or conditions. If this License fails to meet the government's needs or is inconsistent in any respect with federal procurement law, the government agrees to return the Program and Documentation, unused, to The MathWorks, Inc.

Trademarks

MATLAB, Simulink, Stateflow, Handle Graphics, Real-Time Workshop, and xPC TargetBox are registered trademarks of The MathWorks, Inc. Other product or brand names are trademarks or registered trademarks of their respective holders.

Patents

The MathWorks products are protected by one or more U.S. patents. Please see www.mathworks.com/patents for more information.

Revision History

January 1998	First printing	Version 1.0 (Release 10)
September 2000	Second printing	Revised for Version 2.1 (Release 12)
June 2001	Online only	Revised for Version 2.2 (Release 12.1)
July 2002	Online only	Revised for Version 2.3 (Release 13)
	(Renamed from <i>Power System Blockset User's Guide</i>)	
February 2003	Third printing	Revised for Version 3.0 (Release 13SP1)
June 2004	Online only	Revised for Version 3.1 (Release 14)
October 2004	Fourth printing	Revised for Version 4.0 (Release 14SP1)
March 2005	Online only	Revised for Version 4.0.1 (Release 14SP2)
May 2005	Online only	Revised for Version 4.1 (Release 14SP2+)
September 2005	Online only	Revised for Version 4.1.1 (Release 14SP3)
March 2006	Online only	Revised for Version 4.2 (Release 2006a)

Acknowledgments

SimPowerSystems Version 4 was developed by the following people and organizations.

Gilbert Sybille

Hydro-Québec Research Institute (IREQ), Varennes, Québec. Original author of SimPowerSystems, technical coordinator, author of phasor simulation, discretization techniques, and documentation. Technical supervision and design of the FACTS and Distributed Resources libraries, and documentation.

Louis-A. Dessaint

École de Technologie Supérieure, Montréal, Québec. Author of machine models. Technical supervision and design of the electric drive library contents, and documentation.

Pierre Giroux, Richard Gagnon, Silvano Casoria

Hydro-Québec Research Institute (IREQ), Varennes, Québec. Development of the FACTS and Distributed Resources libraries. Key beta testers and developers of several SimPowerSystems blocks, demos, and documentation.

Patrice Brunelle

TransÉnergie Technologies Inc., Montréal, Québec. Main software engineer. Author of graphical user interfaces, model integration into Simulink and Physical Modeling, and documentation.

Roger Champagne

École de Technologie Supérieure (ETS), Montréal, Québec. Authors of machine models, of revised state space formulation. Design of the graphical user interface of the electric drive library.

Hoang Lehuy

Université Laval, Québec City. Validation tests and author of several functions and documentation. Validation of the electric drives library.

Handy Fortin-Blanchette, Olivier Tremblay, Christophe Semaille

École de Technologie Supérieure, Montréal, Québec. Development of the AC and DC drives models.

Hassan Ouquelle, Jean-Nicolas Paquin

École de technologie supérieure, Montréal, Québec. Development of the Single-Phase Asynchronous Machine model and Saturation in Asynchronous Machine model.

Pierre Mercier

iOMEGAt. Project manager for the Power System Blockset 1 and 2 and for the electric drives library of SimPowerSystems.

The authors acknowledge the contributions of the following people:

Innocent Kamwa, Raymond Roussel, Kamal Al-Haddad, Mohamed Tou, Christian Dufour, Momcilo Gavrilovic, Christian Larose, David McCallum, Bahram Khodabakhchian, Manuel Alvarado Sandoval, and Stéphane Desjardins

Getting Started

1

What Is SimPowerSystems?	1-2
The Role of Simulation in Design	1-2
SimPowerSystems Libraries	1-3
Required and Related Products	1-3
Using This Guide	1-4
If You Are a New User	1-4
If You Are an Experienced Blockset User	1-4
All SimPowerSystems Users	1-4
Units	1-4
Building and Simulating a Simple Circuit	1-5
Building the Electrical Circuit with powerlib Library	1-6
Interfacing the Electrical Circuit with Simulink	1-10
Measuring Voltages and Currents	1-12
Basic Principles of Connecting Capacitors and Inductors ...	1-13
Using the Powergui Block to Simulate SimPowerSystems Models	1-14
Analyzing a Simple Circuit	1-16
Electrical State Variables	1-16
State-Space Representation Using power_analyze	1-16
Steady-State Analysis	1-17
Frequency Analysis	1-19
Specifying Initial Conditions	1-25
State Variables	1-25
Initial States	1-26
Specify Initial Electrical States with Powergui	1-27
Simulating Transients	1-30
Continuous, Variable Time Step Integration Algorithms ...	1-32
Discretizing the Electrical System	1-33

Introducing the Phasor Simulation Method	1-36
When to Use the Phasor Solution	1-36
Phasor Simulation of a Circuit Transient	1-37

Advanced Components and Techniques

2

Introducing Power Electronics	2-2
Simulation of the TCR Branch	2-4
Simulation of the TSC Branch	2-7
 Simulating Variable Speed Motor Control	 2-10
Building and Simulating the PWM Motor Drive	2-11
Using the Multimeter Block	2-18
Discretizing the PWM Motor Drive	2-20
Performing Harmonic Analysis Using the FFT Tool	2-20
 Three-Phase Systems and Machines	 2-23
Three-Phase Network with Electrical Machines	2-23
Load Flow and Machine Initialization	2-27
Using the Phasor Solution Method for Stability Studies	2-34
 Building and Customizing Nonlinear Models	 2-38
Modeling a Nonlinear Inductance	2-38
Customizing Your Nonlinear Model	2-44
Modeling a Nonlinear Resistance	2-46
Creating Your Own Library	2-51
Connecting Your Model with Other Nonlinear Blocks	2-51
 Building a Model Using Model Construction Commands .	 2-55

How SimPowerSystems Works	3-2
Choosing an Integration Method	3-5
Continuous Versus Discrete Solution	3-5
Phasor Solution Method	3-5
Simulating with Continuous Integration Algorithms	3-7
Choosing an Integration Algorithm	3-7
Simulating Switches and Power Electronic Devices	3-7
Simulating Discretized Electrical Systems	3-11
Limitations of Discretization with Nonlinear Models	3-11
Simulating Power Electronic Models	3-13
Circuit Using Forced-Commutated Power Electronics	3-13
Circuit Using Naturally Commutated Power Electronics	3-13
Increasing Simulation Speed	3-14
Using Accelerator Mode and Real-Time Workshop	3-14
The Nonlinear Model Library	3-16
The Continuous Library	3-16
The Discrete Library	3-16
The Phasors Library	3-16
The Switch Current Source Library	3-17
Limitations of the Nonlinear Models	3-17
Modifying the Nonlinear Models of the powerlib_models Library	3-17
Creating Your Own Library of Models	3-18
Changing Your Circuit Parameters	3-19
Example of MATLAB Script Performing a Parametric Study	3-19

About the Electric Drives Library	4-2
Getting Started with Electric Drives Library	4-4
What Is an Electric Drive?	4-4
Three Main Components of an Electric Drive	4-5
Multiquadrant Operation	4-7
Average-Value Models	4-8
User Interface	4-10
General Layout of the Library's GUIs	4-10
Features of the New GUIs	4-11
Advanced Usage	4-12
Simulating a DC Motor Drive	4-13
Regenerative Braking	4-14
Example: Thyristor Converter-Based DC Motor Drive	4-14
Simulating an AC Motor Drive	4-38
Dynamic Braking	4-38
Modulation Techniques	4-38
Open-Loop Volts/Hertz Control	4-43
Closed-Loop Speed Control with Slip Compensation	4-44
Flux-Oriented Control	4-44
Direct Torque Control	4-46
Example: AC Motor Drive	4-48
Mechanical Models	4-68
Mechanical Shaft Block	4-68
Speed Reducer Block	4-69
Mechanical Coupling of Two Motor Drives	4-71
System Description	4-71
Speed Regulated AC4 with Torque Regulated DC2	4-73
Torque Regulated AC4 with Speed Regulated DC2	4-74
Winding Machine	4-77
Description of the Winder	4-77
Block Description	4-79

Simulation Results	4-81
Robot Axis Control Using Brushless DC Motor Drive	4-84
Description of the Robot Manipulator	4-84
Position Control Systems for Joints 1 and 2	4-85
Modeling the Robot Position Control Systems	4-86
Tracking Performance of the Motor Drives	4-90
Building Your Own Drive	4-95
Description of the Drive	4-96
Modeling the Induction Motor Drive	4-97
Starting the Drive	4-101
Steady-State Voltage and Current Waveforms	4-102
Speed Regulation Dynamic Performance	4-102

Transients and Power Electronics in Power Systems

5

Series-Compensated Transmission System	5-2
Description of the Transmission System	5-2
Setting the Initial Load Flow and Obtaining Steady State	5-8
Transient Performance for a Line Fault	5-9
Frequency Analysis	5-13
Transient Performance for a Fault at Bus B2	5-17
Thyristor-Based Static Var Compensator	5-20
Description of the SVC	5-20
Steady State and Dynamic Performance of the SVC	5-24
Misfiring of TSC1	5-26
GTO-Based STATCOM	5-29
Description of the STATCOM	5-29
Steady State and Dynamic Performance of the STATCOM ..	5-35
Thyristor-Based HVDC Link	5-39
Description of the HVDC Transmission System	5-39
Frequency Response of the AC and DC Systems	5-41

Description of the Control and Protection Systems	5-43
System Startup/Stop — Steady State and Step Response	5-47
DC Line Fault	5-54
AC Line-to-Ground Fault at the Inverter	5-57
VSC-Based HVDC Link	5-61
Description of the HVDC Link	5-61
VSC Control System	5-65
Dynamic Performance	5-70

Transient Stability of Power Systems Using Phasor Simulation

6

Transient Stability of a Power System with SVC and PSS	6-2
Description of the Transmission System	6-2
Single-Phase Fault — Impact of PSS — No SVC	6-4
Three-Phase Fault — Impact of SVC — PSS in Service	6-6
Control of Power Flow Using a UPFC and a PST	6-8
Description of the Power System	6-8
Power Flow Control with the UPFC	6-11
UPFC P-Q Controllable Region	6-12
Power Flow Control Using a PST	6-13
Wind Farm Using Doubly-Fed Induction Generators	6-18
Turbine Response to a Change in Wind Speed	6-22
Simulation of a Voltage Sag on the 120-kV System	6-24
Simulation of a Fault on the 25-kV System	6-26

SimPowerSystems Block Reference

7

Blocks — By Category	7-2
Creating Electrical Sources	7-4
Creating Circuit Elements	7-4

Modeling Power Electronics Components	7-6
Modeling Electrical Machines	7-6
Modeling Electric Drives	7-7
Modeling FACTS Devices	7-8
Modeling Distributed Resources Devices	7-8
Measuring Electrical Circuits	7-9
Analyzing Electrical Circuits	7-9
Additional Useful Blocks	7-9
Blocks — Alphabetical List	7-11

SimPowerSystems Command Reference

8

Commands — Alphabetical List	8-2
---	------------

Technical Conventions

A

International System of Units	A-2
Per Unit	A-3
What Is the Per Unit System?	A-3
Example 1: Three-Phase Transformer	A-5
Example 2: Asynchronous Machine	A-6
Base Values for Instantaneous Voltage and Current Waveforms	A-7
Why Use the Per Unit System Instead of the Standard SI Units?	A-7

Index

Getting Started

What Is SimPowerSystems? (p. 1-2)	Use SimPowerSystems simulation with other MathWorks products to design electrical power systems
Using This Guide (p. 1-4)	Understand the expected background of users and how to most effectively use this guide
Building and Simulating a Simple Circuit (p. 1-5)	Build a simple circuit with SimPowerSystems blocks and connect it to other Simulink blocks
Analyzing a Simple Circuit (p. 1-16)	Use the Powergui block and analyze static and frequency-domain response
Specifying Initial Conditions (p. 1-25)	Learn about the state variables of a Simulink diagram and specifying initial conditions for the electrical state variables
Simulating Transients (p. 1-30)	Create an electrical subsystem, simulate transients, and discretize simple circuits
Introducing the Phasor Simulation Method (p. 1-36)	Use the phasor method to analyze magnitudes and phases in linear circuits

What Is SimPowerSystems?

SimPowerSystems and SimMechanics of the Physical Modeling product family work together with Simulink to model electrical, mechanical, and control systems.

SimPowerSystems operates in the Simulink® environment. Therefore, before starting this user's guide, you should be familiar with Simulink. For help with Simulink, see the Using Simulink documentation. Or, if you apply Simulink to signal processing and communications tasks (as opposed to control system design tasks), see Getting Started with the Signal Processing Blockset.

The Role of Simulation in Design

Electrical power systems are combinations of electrical circuits and electromechanical devices like motors and generators. Engineers working in this discipline are constantly improving the performance of the systems. Requirements for drastically increased efficiency have forced power system designers to use power electronic devices and sophisticated control system concepts that tax traditional analysis tools and techniques. Further complicating the analyst's role is the fact that the system is often so nonlinear that the only way to understand it is through simulation.

Land-based power generation from hydroelectric, steam, or other devices is not the only use of power systems. A common attribute of these systems is their use of power electronics and control systems to achieve their performance objectives.

SimPowerSystems is a modern design tool that allows scientists and engineers to rapidly and easily build models that simulate power systems. SimPowerSystems uses the Simulink environment, allowing you to build a model using simple *click and drag* procedures. Not only can you draw the circuit topology rapidly, but your analysis of the circuit can include its interactions with mechanical, thermal, control, and other disciplines. This is possible because all the electrical parts of the simulation interact with the extensive Simulink modeling library. Since Simulink uses MATLAB® as its computational engine, designers can also use MATLAB toolboxes and Simulink blocksets. SimPowerSystems and SimMechanics share a special Physical Modeling block and connection line interface.

SimPowerSystems Libraries

You can rapidly put SimPowerSystems to work. The libraries contain models of typical power equipment such as transformers, lines, machines, and power electronics. These models are proven ones coming from textbooks, and their validity is based on the experience of the Power Systems Testing and Simulation Laboratory of Hydro-Québec, a large North American utility located in Canada, and also on the experience of Ecole de Technologie supérieure and Université Laval. The capabilities of SimPowerSystems for modeling a typical electrical system are illustrated in demonstration files. And for users who want to refresh their knowledge of power system theory, there are also self-learning case studies.

Required and Related Products

You must have the following products installed to use SimPowerSystems:

- MATLAB 7.0
- Simulink 6.0

In addition to SimPowerSystems, the Physical Modeling product family includes SimMechanics, for modeling and simulating mechanical systems. Use these products together to model physical systems in Simulink.

There are also a number of closely related toolboxes and other products from the MathWorks that you can use with SimPowerSystems. For more information about any of these products, see the MathWorks Web site at <http://www.mathworks.com>; see the “Products” section.

Using This Guide

If You Are a New User

Begin with this chapter and also the next chapter to learn how to

- Build and simulate electrical circuits using the **powerlib** library
- Interface an electrical circuit with Simulink blocks
- Analyze the steady-state and frequency response of an electrical circuit
- Discretize your model to increase simulation speed, especially for power electronic circuits and large power systems
- Use the phasor simulation method
- Build your own nonlinear models

If You Are an Experienced Blockset User

See the Release Notes for details on the latest release.

Also, see these chapters:

- Chapter 1, “Getting Started” to learn how to simulate discretized electrical circuits
- Chapter 2, “Advanced Components and Techniques” to learn how to apply the phasor simulation to transient stability study of multimachine systems
- Chapter 3, “Improving Simulation Performance” to learn how to increase simulation speed

All SimPowerSystems Users

For reference information on blocks, simple demos, and GUI-based tools, use the “SimPowerSystems Block Reference.”

For commands, refer to the “SimPowerSystems Command Reference” for a synopsis of the command syntax, as well as a complete explanation of options and operation.

Units

This guide uses the International System of Units (SI) and the per unit (p.u.) system. See Appendix A, “Technical Conventions” for details.

Building and Simulating a Simple Circuit

SimPowerSystems allows you to build and simulate electrical circuits containing linear and nonlinear elements.

In this section you

- Explore the **powerlib** library of SimPowerSystems
- Learn how to build a simple circuit from the **powerlib** library
- Interconnect Simulink blocks with your circuit

The section contains discussion of the following topics:

- “Building the Electrical Circuit with powerlib Library” on page 1-6
- “Interfacing the Electrical Circuit with Simulink” on page 1-10
- “Measuring Voltages and Currents” on page 1-12
- “Basic Principles of Connecting Capacitors and Inductors” on page 1-13
- “Using the Powergui Block to Simulate SimPowerSystems Models” on page 1-14

The circuit below represents an equivalent power system feeding a 300 km transmission line. The line is compensated by a shunt inductor at its receiving end. A circuit breaker allows energizing and de-energizing of the line. To simplify matters, only one of the three phases is represented. The parameters shown in the figure are typical of a 735 kV power system.

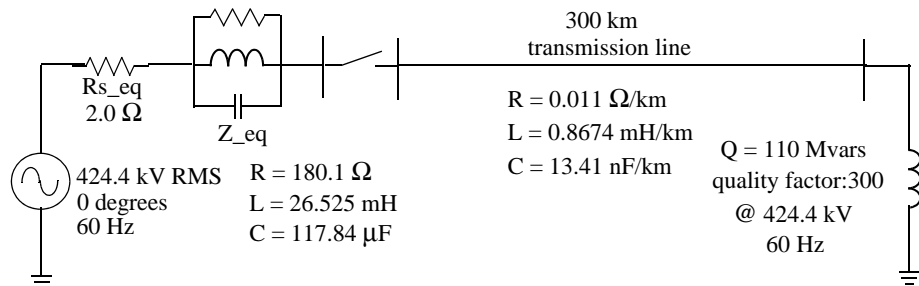

Figure 1-1: Circuit to Be Modeled with SimPowerSystems

Building the Electrical Circuit with powerlib Library

The graphical user interface makes use of the Simulink functionality to interconnect various electrical components. The electrical components are grouped in a library called **powerlib**.

- 1 Open the SimPowerSystems library by entering the following command at the MATLAB prompt.

```
powerlib
```

This command displays a Simulink window showing icons of different block libraries.

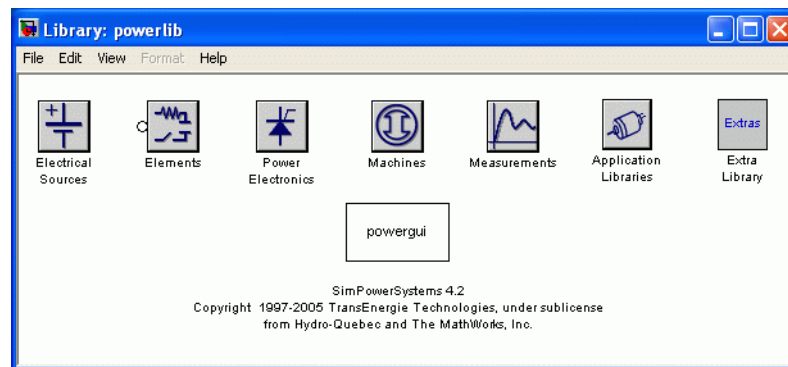

You can open these libraries to produce the windows containing the blocks to be copied into your circuit. Each component is represented by a special icon having one or several inputs and outputs corresponding to the different terminals of the component:

- 2 From the **File** menu of the **powerlib** window, open a new window to contain your first circuit and save it as **circuit1**.
- 3 Open the **Electrical Sources** library and copy the **AC Voltage Source** block into the **circuit1** window.
- 4 Open the **AC Voltage Source** dialog box by double-clicking the icon and enter the **Amplitude**, **Phase**, and **Frequency** parameters according to the values shown in Figure 1-1.

Note that the amplitude to be specified for a sinusoidal source is its peak value ($424.4e3*\sqrt{2}$ volts in this case).

- 5 Change the name of this block from AC Voltage Source to Vs.
- 6 Copy the Parallel RLC Branch block, which can be found in the Elements library of **powerlib**, set its parameters as shown in Figure 1-1, and name it Z_eq.
- 7 The resistance Rs_eq of the circuit can be obtained from the Parallel RLC Branch block. Duplicate the Parallel RLC Branch block, which is already in your **circuit1** window. Select R for the Branch Type parameter and set the R parameter according to Figure 1-1.

Once the dialog box is closed, notice that the L and C components have disappeared so that the icon now shows a single resistor.

Note With the Branch Type parameter set to RLC, setting L and C respectively to ∞ and zero in a parallel branch changes automatically the Branch Type to R and produces the same result. Similarly, with the Series RLC Branch block, setting R, L, and C respectively to zero, zero, and ∞ eliminates the corresponding element.

- 8 Name this block Rs_eq.
- 9 Resize the various components and interconnect blocks by dragging lines from outputs to inputs of appropriate blocks.

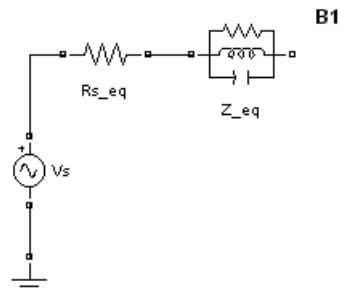

- 10** To complete the circuit of Figure 1-1, you need to add a transmission line and a shunt reactor. You add the circuit breaker later in “Simulating Transients” on page 1-30.

The model of a line with uniformly distributed R, L, and C parameters normally consists of a delay equal to the wave propagation time along the line. This model cannot be simulated as a linear system because a delay corresponds to an infinite number of states. However, a good approximation of the line with a finite number of states can be obtained by cascading several PI circuits, each representing a small section of the line.

A PI section consists of a series R-L branch and two shunt C branches. The model accuracy depends on the number of PI sections used for the model. Copy the PI Section Line block from the Elements library into the **circuit1** window, set its parameters as shown in Figure 1-1, and specify one line section.

- 11** The shunt reactor is modeled by a resistor in series with an inductor. You could use a Series RLC Branch block to model the shunt reactor, but then you would have to manually calculate and set the R and L values from the quality factor and reactive power specified in Figure 1-1.

Therefore, you might find it more convenient to use a Series RLC Load block that allows you to specify directly the active and reactive powers absorbed by the shunt reactor.

Copy the Series RLC Load block, which can be found in the Elements library of **powerlib**. Name this block 110 Mvar. Set its parameters as follows:

Vn 424.4e3 V
fn 60 Hz
P 110e6/300 W (quality factor = 300)
QL 110e6 vars
Qc 0

Note that, as no reactive capacitive power is specified, the capacitor disappears on the block icon when the dialog box is closed. Interconnect the new blocks as shown.

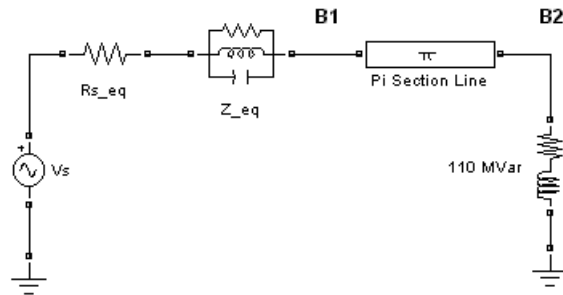

- 12** You need a Voltage Measurement block to measure the voltage at node B1. This block is found in the Measurements library of **powerlib**. Copy it and name it U1. Connect its positive input to the node B1 and its negative input to a new Ground block.
- 13** To observe the voltage measured by the Voltage Measurement block named U1, a display system is needed. This can be any device found in the Sinks library of Simulink.

Open the Sinks library of Simulink and copy the Scope block into your **circuit1** window. If the scope were connected directly at the output of the voltage measurement, it would display the voltage in volts. However, electrical engineers in power systems are used to working with normalized quantities (per unit system). The voltage is normalized by dividing the value in volts by a base voltage corresponding to the peak value of the system nominal voltage. In this case the scaling factor K is

$$K = \frac{1}{424.4 \times 10^3 \times \sqrt{2}}$$

- 14** Copy a Gain block from the Simulink library and set its gain as above. Connect its output to the Scope block and connect the output of the Voltage Measurement block to the Gain block. Duplicate this voltage measurement system at the node B2, as shown below.

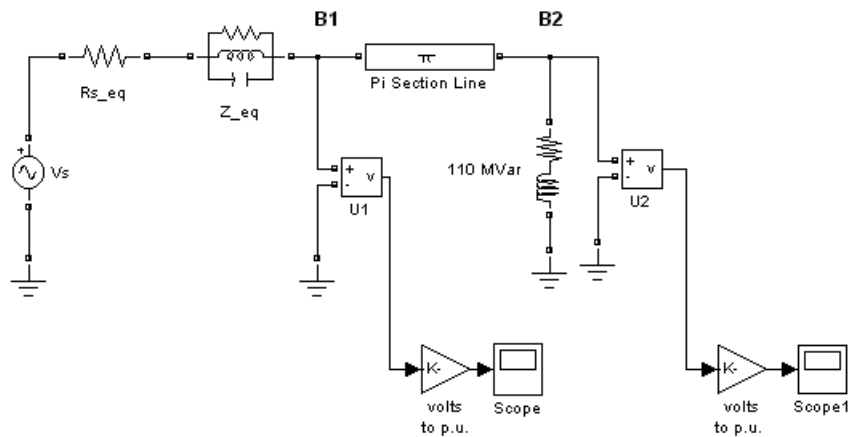

15 From the **Simulation** menu, select **Start**. In Microsoft Windows, you can also click the **Start** button in the model window toolbar. A Powergui block is automatically added to your model. The purpose of this block is discussed in “Using the Powergui Block to Simulate SimPowerSystems Models” on page 1-14.

16 Open the Scope blocks and observe the voltages at nodes B1 and B2.

17 While the simulation is running, open the Vs block dialog box and modify the amplitude. Observe the effect on the two scopes. You can also modify the frequency and the phase. You can zoom in on the waveforms in the scope windows by drawing a box around the region of interest with the left mouse button.

To simulate this circuit, the default integration algorithm (ode45) was used. However, for most applications of SimPowerSystems, your circuits contain switches and other nonlinear models. In such a case, you must specify a different integration algorithm. This is discussed in “Simulating Transients” on page 1-30, where a circuit breaker is added to your circuit.

Interfacing the Electrical Circuit with Simulink

The Voltage Measurement block acts as an interface between the SimPowerSystems blocks and the Simulink blocks. For the system shown above, you implemented such an interface from the electrical system to the

Simulink system. The Voltage Measurement block converts the measured voltages into Simulink signals.

Similarly, the Current Measurement block from the Measurements library of **powerlib** can be used to convert any measured current into a Simulink signal.

You can also interface from Simulink blocks to the electrical system. For example, you can use the Controlled Voltage Source block to inject a voltage in an electrical circuit, as shown in the following figure.

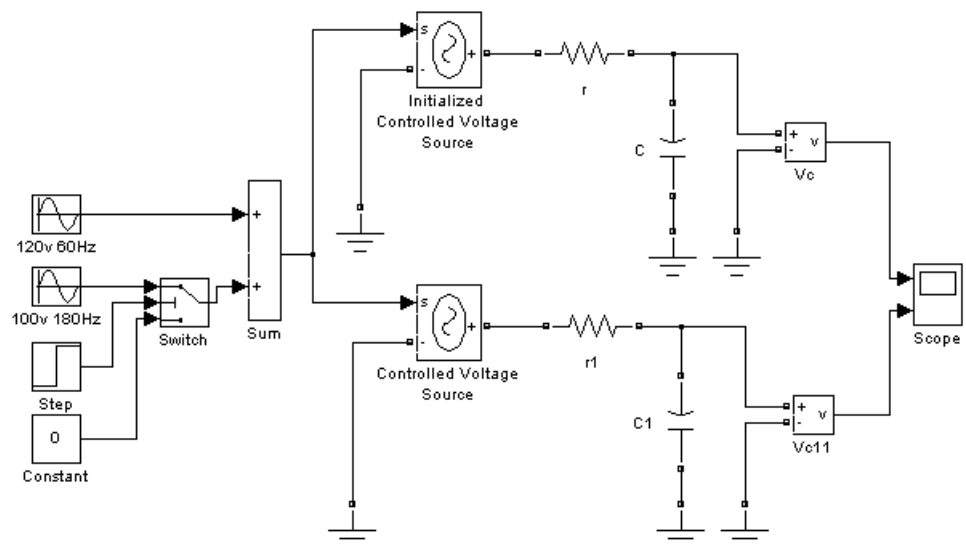

Electrical Terminal Ports and Connection Lines SimPowerSystems is part of the Physical Modeling environment. Its blocks often feature both normal Simulink input and output ports > and special electrical terminal ports □:

- Lines that connect normal Simulink ports > are directional signal lines.
- Lines that connect terminal ports □ are special electrical connection lines. These lines are nondirectional and can be branched, but you cannot connect them to Simulink ports > or to normal Simulink signal lines.
- You can connect Simulink ports > only to other Simulink ports and terminal ports □ only to other terminal ports.
- Converting Simulink signals to electrical connections or vice versa requires using a SimPowerSystems block that features both Simulink and terminal ports.

Some SimPowerSystems blocks feature only one type of port.

Measuring Voltages and Currents

When you measure a current using a Current Measurement block, the positive direction of current is indicated on the block icon (positive current flowing from + terminal to – terminal). Similarly, when you measure a voltage using a Voltage Measurement block, the measured voltage is the voltage of the + terminal with respect to the – terminal. However, when voltages and currents of blocks from the Elements library are measured using the Multimeter block, the voltage and current polarities are not immediately obvious because blocks might have been rotated and there are no signs indicating polarities on the block icons.

Unlike Simulink signal lines and input and output ports, the Physical Modeling connection lines and terminal ports □ of SimPowerSystems lack intrinsic directionality. The voltage and current polarities are determined, not by line direction, but instead by block orientation. To find out a block orientation, first click the block to select it. Then enter the following command.

```
get_param(gcf, 'Orientation')
```

The following table indicates the polarities of the currents and voltages measured with the Multimeter block for single-phase and three-phase RLC branch and loads (and of the polarity of the capacitor voltage and the inductor current), surge arresters, and single-phase and three-phase breakers.

Block Orientation	Positive Current Direction	Measured Voltage
right	left → right	$V_{\text{left}} - V_{\text{right}}$
left	right → left	$V_{\text{right}} - V_{\text{left}}$
down	top → bottom	$V_{\text{top}} - V_{\text{bottom}}$
up	bottom → top	$V_{\text{bottom}} - V_{\text{top}}$

The natural orientation of the blocks (that is, their orientation in the Element library) is *right* for horizontal blocks and *down* for vertical blocks.

For single-phase transformers (linear or saturable), with the winding connectors appearing on the left and right sides, the winding voltages are the voltages of the top connector with respect to the bottom connector, irrespective of the block orientation (*right* or *left*). The winding currents are the currents entering the top connector.

For three-phase transformers, the voltage polarities and positive current directions are indicated by the signal labels used in the Multimeter block. For example, $U_{\text{an_w2}}$ means phase A-to-neutral voltage of the Y connected winding #2, $I_{\text{ab_w1}}$ means winding current flowing from A to B in the delta-connected winding #1.

Basic Principles of Connecting Capacitors and Inductors

You have to pay particular attention when you connect capacitor elements together with voltage sources, or inductor elements in series with current sources. When you start the simulation, SimPowerSystems will signal an error if one of the following two connection errors are present in your diagram:

- 1 You have connected a voltage source in parallel with a capacitor, or a series of capacitor elements in series, like in the two examples below.

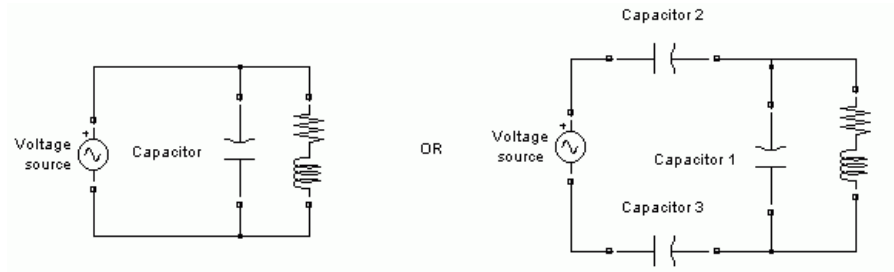

To fix this problem, you can add a small resistance in series between the voltage source and the capacitors.

- 2 You have connected a current source in series with an inductor, or a series of inductor elements connected in parallel, like in the example below.

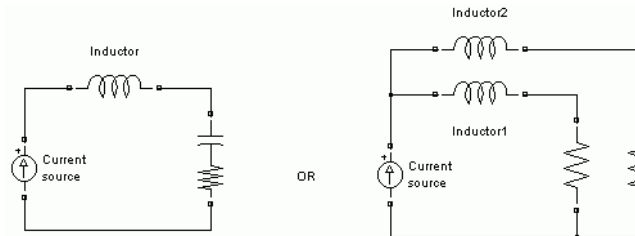

To fix this problem, you can add a large resistance in parallel with the inductor and the capacitors.

Using the Powergui Block to Simulate SimPowerSystems Models

The Powergui block is necessary for simulation of any Simulink model containing SimPowerSystems blocks. It is used to store the equivalent Simulink circuit that represents the state-space equations of the SimPowerSystems blocks.

You must follow these rules when using this block in a model:

- Place the Powergui block at the top level of diagram for optimal performance. However, you can place it anywhere inside subsystems for your convenience; its functionality will not be affected.
- You can have a maximum of one Powergui block per model
- You must name the block powergui

Note When you start the simulation, SimPowerSystems will automatically add a Powergui block at the top level of a diagram if no such block is found in your model.

Analyzing a Simple Circuit

In this section you

- Obtain the state-space representation of your model with the `power_analyze` command
- Compute the steady-state voltages and currents using the graphical user interface of the Powergui block
- Analyze an electrical circuit in the frequency domain

Electrical State Variables

The electrical state variables are the Simulink states of your diagram associated to the capacitor and inductor devices of the SimPowerSystems blocks. Inductors and capacitors elements are found in the RLC-branch type blocks such as the Series RLC Branch block, Three-Phase Parallel RLC Load block, in the transformer models, in the PI Section Line block, in the snubber devices of the power electronic devices, etc.

The electrical state variables consist of the inductor currents and the capacitor voltages. In SimPowerSystems, the electrical state variable names contain the name of the block where the inductor or capacitor is found, preceded by the `I1_` prefix for inductor currents or the `Uc_` prefix for capacitor voltages.

State-Space Representation Using `power_analyze`

You compute the state-space representation of the model `circuit1` with the `power_analyze` command. Enter the following command at the MATLAB prompt.

```
[A,B,C,D,x0,electrical_states,inputs,outputs]=power_analyze('circuit1')
```

The `power_analyze` command returns the state-space model of your circuit in the four matrices A, B, C, and D. `x0` is the vector of initial conditions of the electrical states of your circuit. The names of the electrical state variables, inputs, and outputs are returned in three string matrices.

```
electrical_states =  
  
I1_110 Mvars  
Uc_input PI Section Line
```

```
I1_sect1 PI Section Line
Uc_output PI Section Line
I1_Z_eq
Uc_Z_eq

inputs =

U_Vs

outputs =

U_U1
U_U2
```

Note that you could have obtained the names and ordering of the electrical states, inputs, and outputs directly from the Powergui block. See the `power_analyze` reference page for more details on how to use this function.

Steady-State Analysis

To facilitate the steady-state analysis of your circuit, the **powerlib** library includes a graphical user interface tool. If the Powergui block is not already present in your model, copy the block from the library into your **circuit1** model and double-click the block icon to open it.

From the **Analysis tools** menu of the Powergui block, select **Steady-State Voltages and Currents**. This opens the **Steady-State Tool** window where the steady-state phasors voltages measured by the two voltage measurement blocks of your model are displayed in polar form.

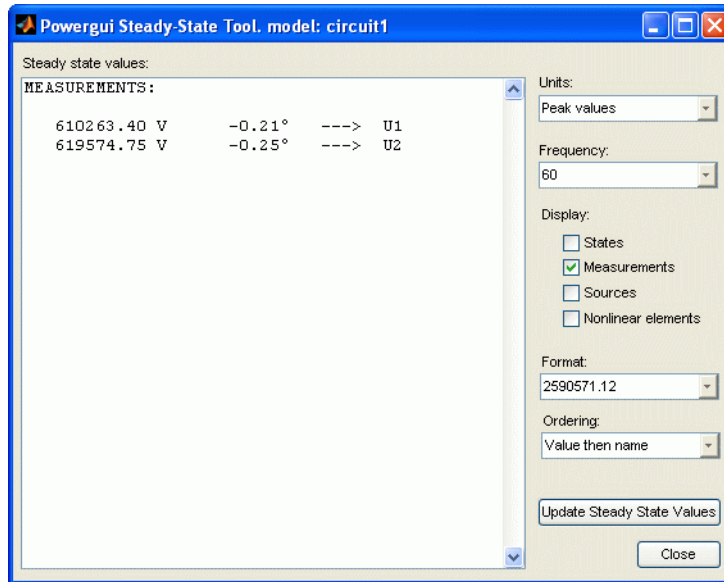

Each measurement output is identified by a string corresponding to the measurement block name. The magnitudes of the phasors U1 and U2 correspond to the peak value of the sinusoidal voltages.

From the **Steady-State Tool** window, you can also display the steady-state values of the source voltage or the steady-state values of the inductor currents and capacitor voltages by selecting either the **Sources** or the **States** check box.

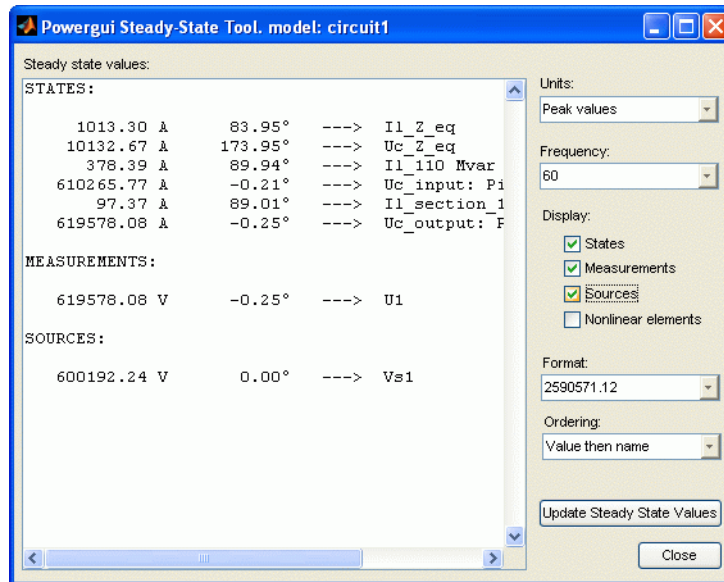

Note Depending on the order you added the blocks in your `circuit1` diagram, the electrical state variables might not be ordered in the same way as in the preceding figure.

Refer to the section “Measuring Voltages and Currents” on page 1-12 for more details on the sign conventions used for the voltages and currents of sources and electrical state variables listed in the **Steady-State Tool** window.

Frequency Analysis

The Measurements library of **powerlib** contains an Impedance Measurement block that measures the impedance between any two nodes of a circuit. In the following two sections, you measure the impedance of your circuit between node B2 and ground by using two methods:

- Calculation from the state-space model
- Automatic measurement using the Impedance Measurement block and the Powergui block

Obtaining the Impedance vs. Frequency Relation from the State-Space Model

To measure the impedance versus frequency at node B2, you need a current source at node B2 providing a second input to the state-space model. Open the Electrical Sources library and copy the AC Current Source block into your model. Connect this source at node B2, as shown below. Set the current source magnitude to zero and keep its frequency at 60 Hz. Rearrange the blocks as follows.

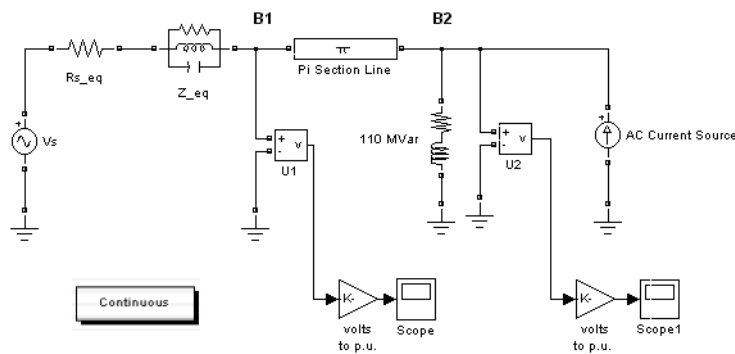

AC Current Source at the B2 Node

Now compute the state-space representation of the model circuit1 with the `power_analyze` command. Enter the following command at the MATLAB prompt.

```
[A,B,C,D]=power_analyze('circuit1')
```

Once the state-space model of the system is known, it can be analyzed in the frequency domain. For example, the modes of this circuit can be found from the eigenvalues of matrix A (use the MATLAB `eig` command).

```
eig(A)
ans =

1.0e+05 *
-2.4972
-0.0001 + 0.0144i <- 229 Hz
-0.0001 - 0.0144i
-0.0002 + 0.0056i <- 89 Hz
```

```
-0.0002 - 0.0056i
-0.0000
```

This system has two oscillatory modes at 89 Hz and 229 Hz. The 89 Hz mode is due to the equivalent source, which is modeled by a single pole equivalent. The 229 Hz mode is the first mode of the line modeled by a single PI section.

Note If you have Control System Toolbox installed, you can compute the impedance of the network as a function of frequency by using the bode function.

In the Laplace domain, the impedance Z_2 at node B2 is defined as the transfer function between the current injected at node B2 (input 2 of the system) and the voltage measured at node B2 (output 2 of the system).

$$Z_2(s) = \frac{U_2(s)}{I_2(s)}$$

The impedance at node B2 for the 0 to 1500 Hz range can be calculated and displayed as follows.

```
freq=0:1500;
w=2*pi*freq;
[mag1,phase1]=bode(A,B,C,D,2,w);
semilogy(freq,mag1(:,2));
```

Repeat the same process to get the frequency response with a 10 section line model. Open the **PI Section Line** dialog box and change the number of sections from 1 to 10. To calculate the new frequency response and superimpose it upon the one obtained with a single line section, enter the following commands.

```
[A,B,C,D]=power_analyze('circuit1');
[mag10,phase10]=bode(A,B,C,D,2,w);
semilogy(freq,mag1(:,2),freq,mag10(:,2));
```

This is the resulting plot.

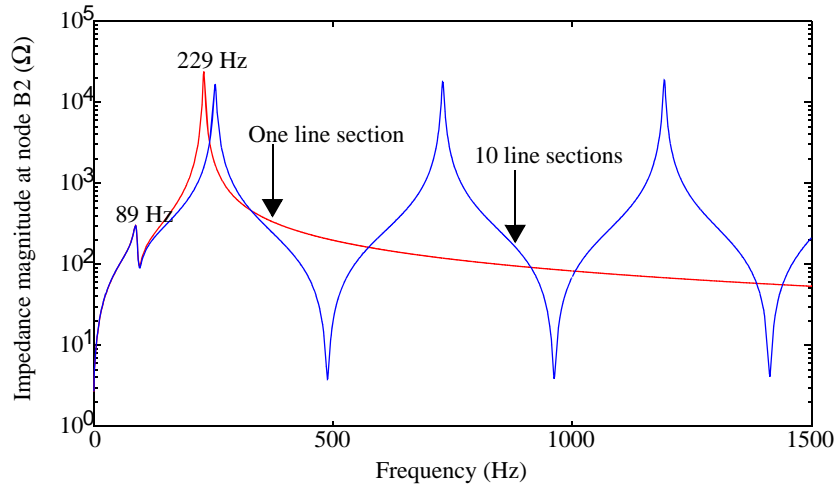

Figure 1-2: Impedance at Node B2 as Function of Frequency

This graph indicates that the frequency range represented by the single line section model is limited to approximately 150 Hz. For higher frequencies, the 10 line section model is a better approximation.

For a distributed parameter line model the propagation speed is

$$v = \frac{1}{\sqrt{L \cdot C}} = 293,208 \text{ km/s}$$

The propagation time for 300 km is therefore $T = 300/293,208 = 1.023 \text{ ms}$ and the frequency of the first line mode is $f_1 = 1/4T = 244 \text{ Hz}$. A distributed parameter line would have an infinite number of modes every $244 + n \cdot 488 \text{ Hz}$ ($n = 1, 2, 3, \dots$). The 10 section line model simulates the first 10 modes. The first three line modes can be seen in Figure 1-2 (244 Hz, 732 Hz, and 1220 Hz).

Obtaining the Impedance vs. Frequency Relation from the Impedance Measurement and Powergui Blocks

The process described above to measure a circuit impedance has been automated in SimPowerSystems. Open the Measurements library of **powerlib**, copy the Impedance Measurement block into your model, and rename it ZB2. Connect the two inputs of this block between node B2 and ground as shown.

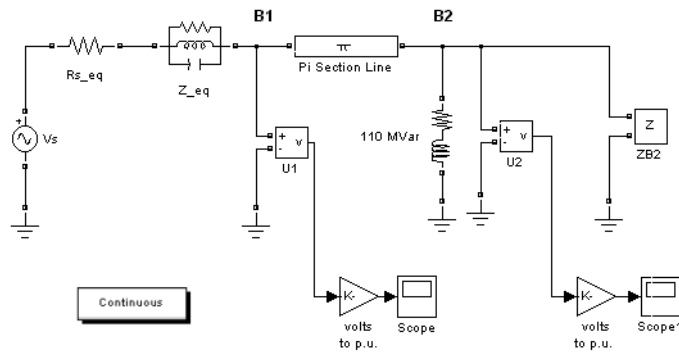

Measuring Impedance vs. Frequency with the Impedance Measurement Block

Now open the Powergui dialog. In the **Tools** menu, select **Impedance vs Frequency Measurement**. A new window opens, showing the list of Impedance Measurement blocks available in your circuit.

In your case, only one impedance is measured, and it is identified by ZB2 (the name of the ZB2 block) in the window. Fill in the frequency range by entering 0:2:1500 (zero to 1500 Hz by steps of 2 Hz). Select the logarithmic scale to display Z magnitude. Select the **Save data when updated** check box and enter ZB2 as the variable name to contain the impedance vs. frequency. Click the **Display/Save** button.

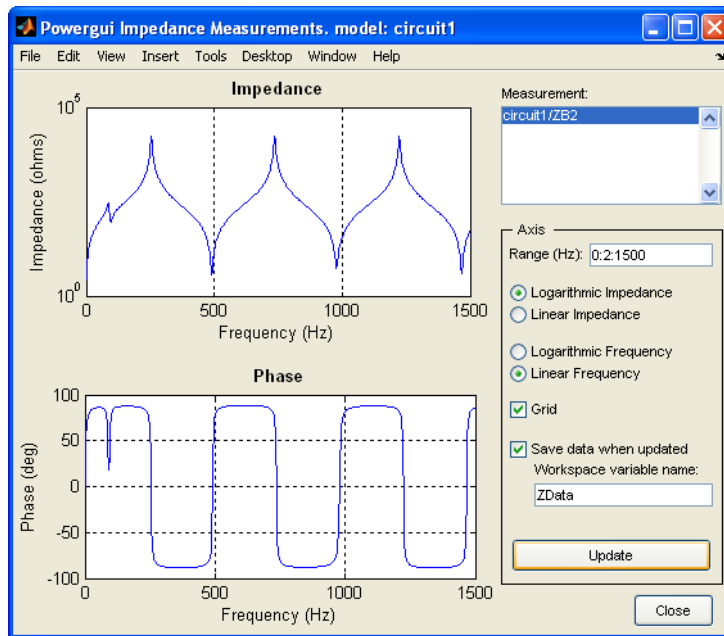

When the calculation is finished, the window displays the magnitude and phase as functions of frequency. The magnitude should be identical to the plot (for one line section) shown in Figure 1-2. If you look in your workspace, you should have a variable named ZB2. It is a two-column matrix containing frequency in column 1 and complex impedance in column 2.

Specifying Initial Conditions

In this section you

- Learn what are the state variables of a Simulink diagram containing SimPowerSystems blocks
- Specify initial conditions for the electrical state variables

State Variables

The state variables of a Simulink diagram containing SimPowerSystems blocks consist of

- The electrical states associated to RLC branch-type blocks of SimPowerSystems. They are defined by the state-space representation of your model. See “Electrical State Variables” on page 1-16 for more details about the electrical states.
- The Simulink states of the Electrical Simulink models of SimPowerSystems such as the Synchronous Machine block, the Saturable Transformer block, or the Three-Phase Dynamic Load block.
- The Simulink states of the other Simulink blocks of your model (controls, user-defined blocks, and other blocksets).

The following picture provides an example that contains the three types of state variables:

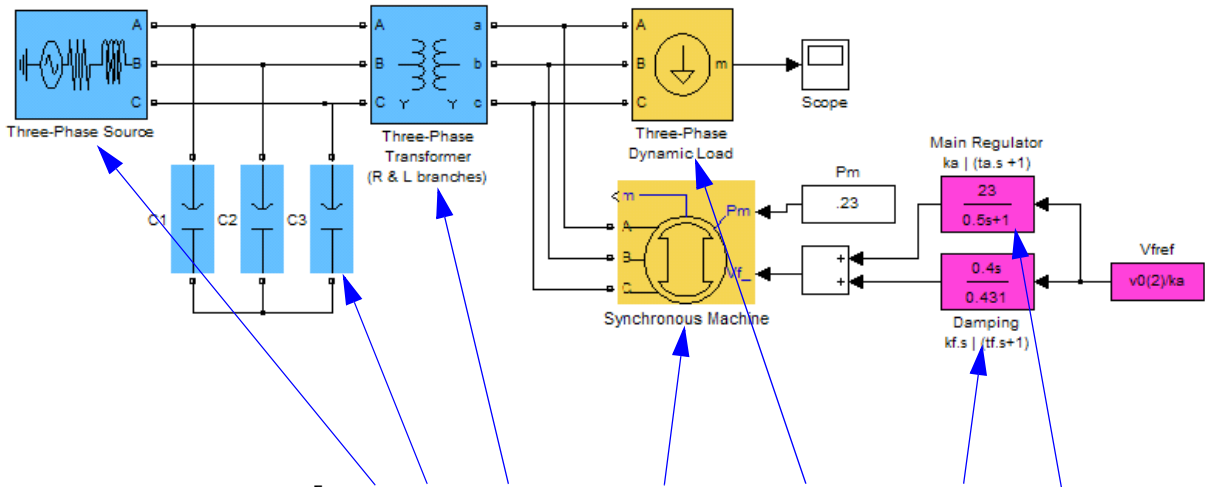

$$\mathbf{X} = [[X_{1_electric} \dots X_{n_electric}], [X_{1_model} \dots X_{n_model}], [X_{1_simulink} \dots]]$$

Initial States

Initial conditions, which are applied to the entire system at the start of the simulation, are generally set in the blocks. Most of the Simulink blocks allow you to specify initial conditions. For the case of the electrical states SimPowerSystems automatically sets the initial values of the electrical states to start the simulation in steady state.

However, you can specify the initial conditions for the capacitor voltage and inductor currents in the mask of these blocks:

- the Series and Parallel RLC Branch blocks
- the Series and Parallel RLC Load blocks

The initial values entered in the mask of these block will overwrite the default steady-state parameters calculated by SimPowerSystems. In the same sense, you can overwrite initial conditions of the overall blocks by specifying them in the **States** area of the **Simulation Parameters** pane.

See the `power_init` function reference page for more details on how you can specify initial states for a Simulink diagram with SimPowerSystems blocks.

Specify Initial Electrical States with Powergui

- 1 Open the SimPowerSystems demo entitled Transient Analysis of a Linear Circuit by typing `power_transient` at the command line. Rename the RLC Branch blocks as shown in the next figure.

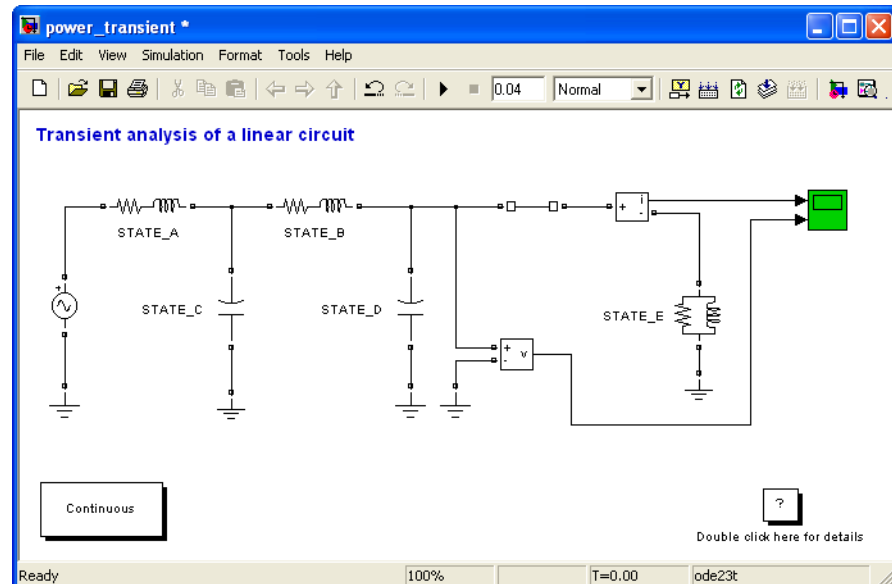

- 2 From the **Analysis tools** menu of the Powergui block, select **Initial State Settings**. The initial values of the five electrical state variables (three inductor currents and two capacitor voltages) are displayed. These initial values corresponds to the values SimPowerSystems automatically sets to start the simulation in steady state.

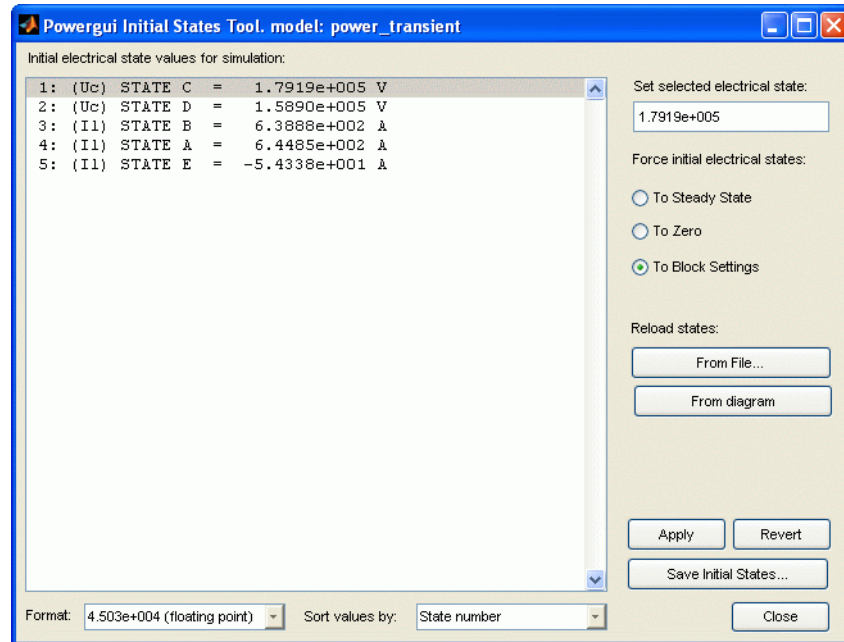

- 3 Open the Scope block and start the simulation. As the electrical state variables are automatically initialized, the system starts in steady state and sinusoidal waveforms are observed.
- 4 The initial value for STATE_D state is set to 1.589×10^5 V. It corresponds to the initial capacitor voltage found in the STATE_D block. Open this block, select the **Set the initial capacitor voltage** parameter, then specify a capacitor initial voltage of -2×10^5 V. Click the **OK** button.
- 5 Click the **From diagram** button of the Powergui Initial States Tool to refresh the display of initial states. The initial state of STATE_D block is now set to -2×10^5 V.
- 6 Start the simulation. In the second trace of the Scope block, zoom around the transient at the beginning of the simulation. As expected, the model does not start in steady state, but the initial value for the capacitor voltage measured by the Voltage Measurement block is -2×10^5 V.

- 7 Select the STATE_A state variable in the **Initial States Tool** list. In the **Set selected electrical state** field, set the initial inductor current to 50 A. Open the mask of the STATE_A block, and note that the **Set the initial inductor current** parameter is selected and the initial inductor current is set to 50 A.

Run the simulation and observe the new transient caused by this new setting.

Using the Force Initial State to Zero Check Box

Now suppose that you want to reset all the initial electrical states to zero without losing the settings you have done in the previous steps.

- 1 From the Initial State Tool window, select the **To zero** check box under **Force initial electrical state**, then click **Apply**. Restart the simulation and observe the transient when all the initial conditions starts from zero.
- 2 Open the masks of the STATE_C and STATE_A blocks and note that even if initial conditions are still specified in these blocks, the setting for the initial states is forced to zero by the Powergui block.

A message is displayed at the command line to remind you every time you start the simulation that the electrical initial states of your model are forced to zero by the Powergui block, which overwrites the block settings in your model.

Using the Force Initial State to Steady State Check Box

Similarly, you can set all the initial states to steady without losing the settings you have done in the previous steps.

- 1 From the Initial State Tool window, select the **To steady state** check box under **Force initial electrical state**, then click **Apply**.
- 2 Restart the simulation and observe that the simulation starts in steady state.

A message is displayed at the command line to remind you every time you start the simulation that the electrical initial states of your model are forced to steady state by the Powergui block.

Using the Force Initial State to Block Settings Check Box

To return to the block settings, select the **To block settings** check box under **Force initial electrical state**, then click **Apply**.

Simulating Transients

In this section you

- Learn how to create an electrical subsystem
- Simulate transients with a circuit breaker
- Compare time domain simulation results with different line models
- Learn how to discretize a circuit and compare results thus obtained with results from a continuous, variable time step algorithm

One of the main uses of SimPowerSystems is to simulate transients in electrical circuits. This can be done with either mechanical switches (circuit breakers) or switches using power electronic devices.

First open your `circuit1` system and delete the current source connected at node B2. Save this new system as `circuit2`. Before connecting a circuit breaker, you need to modify the schematic diagram of `circuit2`. As with Simulink, SimPowerSystems allows you to group several components into a subsystem. This feature is useful to simplify complex schematic diagrams.

Use this feature to transform the source impedance into a subsystem:

- 1 Select the two blocks identified as `Rs_eq` and `Z_eq` by surrounding them by a box with the left mouse button and use the **Edit** → **Create subsystem** menu item. The two blocks now form a new block called Subsystem.

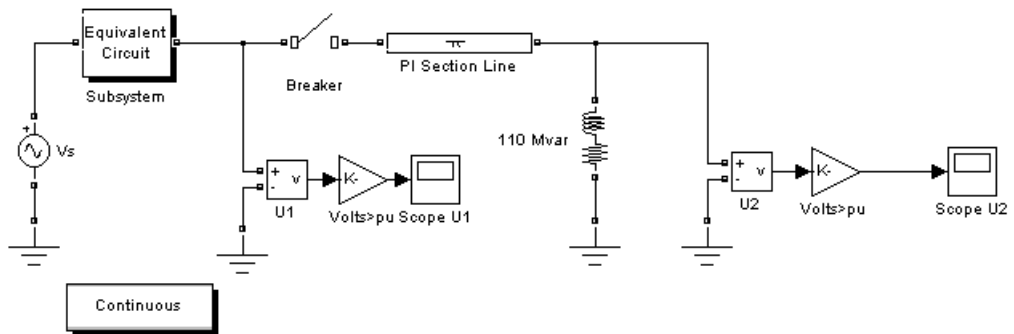

- 2 Using the **Edit** → **Mask subsystem** menu item, change the icon of that subsystem. In the **Icon** section of the mask editor, enter the following drawing command:

```
disp('Equivalent\nCircuit')
```

The icon now reads Equivalent Circuit, as shown in the figure above.

- 3 Use the **Format** → **Show drop shadow** menu item to add a drop shadow to the Subsystem block.
- 4 You can double-click the Subsystem block and look at its content.
- 5 Insert a circuit breaker into your circuit to simulate a line energization by opening the Elements library of **powerlib**. Copy the Breaker block into your **circuit2** window.

The circuit breaker is a nonlinear element modeled by an ideal switch in series with a resistance. Because of modeling constraints, this resistance cannot be set to zero. However, it can be set to a very small value, say 0.001Ω , that does not affect the performance of the circuit:

- 1 Open the Breaker block dialog box and set its parameters as follows:

Ron	0.001 Ω
Initial state	0 (open)
Rs	inf
Cs	0
Switching times	[(1/60) / 4]

- 2 Insert the circuit breaker in series with the sending end of the line, then rearrange the circuit as shown in the previous figure.
- 3 Open the scope U2 and click the **Parameters** icon and select the **Data history** tab. Click the **Save data to workspace** button and specify a variable name U2 to save the simulation results; then change the **Format** option for U2 to be **Array**. Also, clear **Limit rows to last** to display the entire waveform for long simulation times.

You are now ready to simulate your system.

Continuous, Variable Time Step Integration Algorithms

Open the **PI section Line** dialog box and make sure the number of sections is set to 1. Open the **Simulation** → **Simulation parameters** dialog box. As you now have a system containing switches, you need a stiff integration algorithm to simulate the circuit. In the **Solver** pane, select the variable-step stiff integration algorithm `ode23t`.

Keep the default parameters (relative tolerance set at $1e-3$) and set the stop time to 0.02 seconds. Open the scopes and start the simulation. Look at the waveforms of the sending and receiving end voltages on ScopeU1 and ScopeU2.

Once the simulation is complete, copy the variable U2 into U2_1 by entering the following command in the MATLAB Command Window.

```
U2_1 = U2;
```

These two variables now contain the waveform obtained with a single PI section line model.

Open the **PI section Line** dialog box and change the number of sections from 1 to 10. Start the simulation. Once the simulation is complete, copy the variable U2 into U2_10.

Before modifying your circuit to use a distributed parameter line model, save your system as `circuit2_10pi`, which you can reuse later.

Delete the PI section line model and replace it with a single-phase Distributed Parameter Line block. Set the number of phases to 1 and use the same R, L, C, and length parameters as for the PI section line (see Figure 1-1). Save this system as `circuit2_dist`.

Restart the simulation and save the U2 voltage in the U2_d variable.

You can now compare the three waveforms obtained with the three line models. Each variable U2_1, U2_10, and U2_d is a two-column matrix where the time is in column 1 and the voltage is in column 2. Plot the three waveforms on the same graph by entering the following command.

```
plot(U2_1(:,1), U2_1(:,2), U2_10(:,1), U2_10(:,2),  
U2_d(:,1), U2_d(:,2));
```

These waveforms are shown in the next figure. As expected from the frequency analysis performed during “Analyzing a Simple Circuit” on page 1-16, the

single PI model does not respond to frequencies higher than 229 Hz. The 10 PI section model gives a better accuracy, although high-frequency oscillations are introduced by the discretization of the line. You can clearly see in the figure the propagation time delay of 1.03 ms associated with the distributed parameter line.

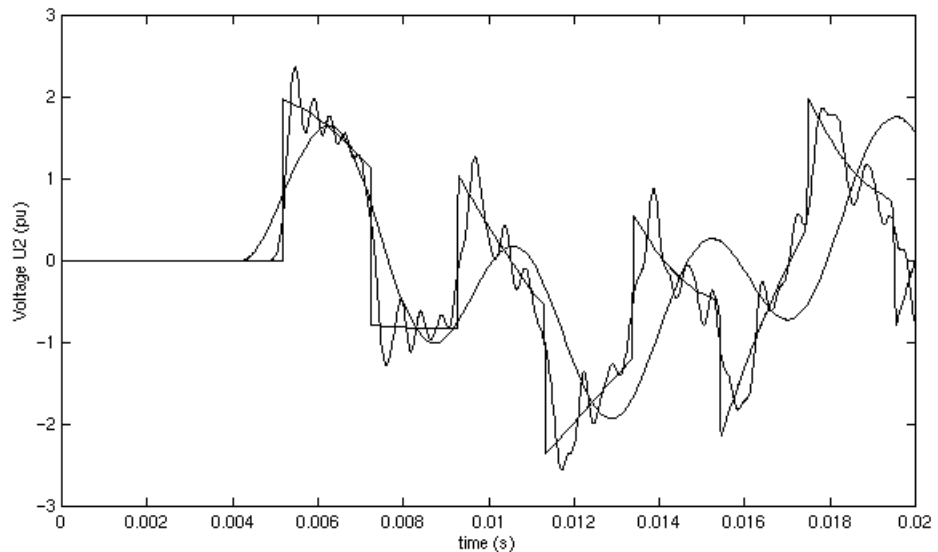

Receiving End Voltage Obtained with Three Different Line Models

Discretizing the Electrical System

An important feature of SimPowerSystems is its ability to simulate either with continuous, variable step integration algorithms or with discrete solvers. For small systems, variable time step algorithms are usually faster than fixed step methods, because the number of integration steps is lower. For large systems that contain many states or many nonlinear blocks such as power electronic switches, however, it is advantageous to discretize the electrical system.

When you discretize your system, the precision of the simulation is controlled by the time step. If you use too large a time step, the precision might not be sufficient. The only way to know if it is acceptable is to repeat the simulation with different time steps and find a compromise for the largest acceptable time step. Usually time steps of 20 μ s to 50 μ s give good results for simulation of

switching transients on 50 Hz or 60 Hz power systems or on systems using line-commutated power electronic devices such as diodes and thyristors. You must reduce the time step for systems using forced-commutated power electronic switches. These devices, the insulated-gate bipolar transistor (IGBT), the field-effect transistor (FET), and the gate-turnoff thyristor (GTO) are operating at high switching frequencies.

For example, simulating a pulse-width-modulated (PWM) inverter operating at 8 kHz would require a time step of at most 1 μ s.

You now learn how to discretize your system and compare simulation results obtained with continuous and discrete systems. Open the `circuit2_10pi` system that you saved from a previous simulation. This system contains 24 electrical states and one switch. Open the Powergui and select **Discretize electrical model**. Set the sample time to $25e-6$ s. When you restart the simulation, the power system is discretized using the Tustin method (corresponding to trapezoidal integration) using a 25 μ s sample time.

Open the **Simulation** \rightarrow **Simulation parameters** \rightarrow **Solver** dialog box and set the simulation time to 0.2 s. Start the simulation.

Note Once the system is discretized, there are no more continuous states in the electrical system. So you do not need a variable-step integration method to simulate. In the **Simulation** \rightarrow **Simulation parameters** \rightarrow **Solver** dialog box, you could have selected the Fixed-step and discrete (no continuous states) options and specified a fixed step of 25 μ s.

To measure the simulation time, you can restart the simulation by entering the following commands.

```
tic; sim(gcs); toc
```

When the simulation is finished the elapsed time in seconds is displayed in the MATLAB Command Window.

To return to the continuous simulation, open the Powergui block and select **Continuous**. If you compare the simulation times, you find that the discrete system simulates approximately 3.5 times faster than the continuous system.

To compare the precision of the two methods, perform the following three simulations:

- 1 Simulate a continuous system, with $T_s = 0$.
- 2 Simulate a discrete system, with $T_s = 25 \mu\text{s}$.
- 3 Simulate a discrete system, with $T_s = 50 \mu\text{s}$.

For each simulation, save the voltage U2 in a different variable. Use respectively U2c, U2d25, and U2d50. Plot the U2 waveforms on the same graph by entering the following command.

```
plot(U2c(:,1), U2c(:,2), U2d25(:,1),U2d25(:,2),
     U2d50(:,1),U2d50(:,2))
```

Zoom in on the 4 to 12 ms region of the plot window to compare the differences on the high-frequency transients. The $25 \mu\text{s}$ compares reasonably well with the continuous simulation. However, increasing the time step to $50 \mu\text{s}$ produces appreciable errors. The $25 \mu\text{s}$ time step would therefore be acceptable for this circuit, while obtaining a gain of 3.5 on simulation speed.

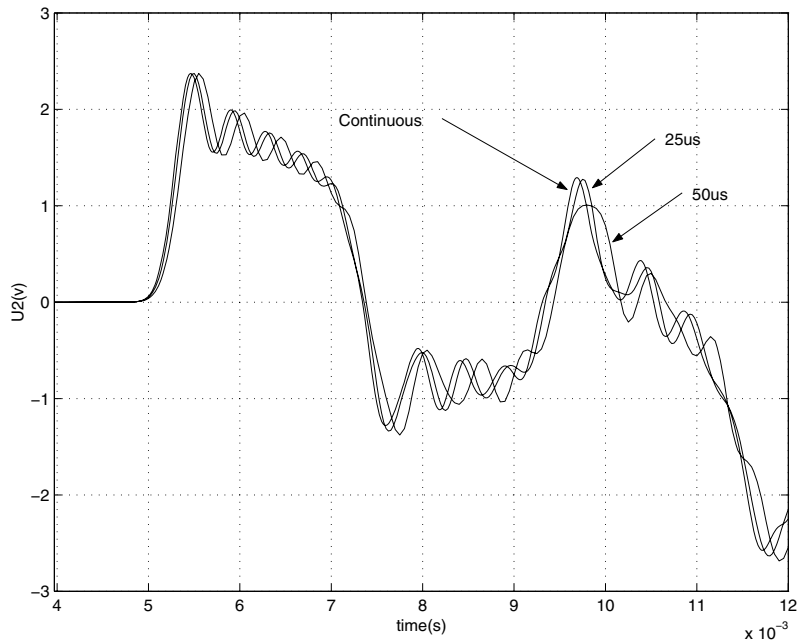

Comparison of Simulation Results for Continuous and Discrete Systems

Introducing the Phasor Simulation Method

In this section, you

- Apply the phasor simulation method to a simple linear circuit
- Learn advantages and limitations of this method

Up to now you have used two methods to simulate electrical circuits:

- Simulation with variable time steps using the continuous Simulink solvers
- Simulation with fixed time steps using a discretized system

This section explains how to use a third simulation method, the phasor solution method.

When to Use the Phasor Solution

The phasor solution method is mainly used to study electromechanical oscillations of power systems consisting of large generators and motors. An example of this method is the simulation of a multimachine system in “Three-Phase Systems and Machines” on page 2-23. However, this technique is not restricted to the study of transient stability of machines. It can be applied to any linear system.

If, in a linear circuit, you are interested only in the changes in magnitude and phase of all voltages and currents when switches are closed or opened, you do not need to solve all differential equations (state-space model) resulting from the interaction of R, L, and C elements. You can instead solve a much simpler set of algebraic equations relating the voltage and current phasors. This is what the phasor solution method does. As its name implies, this method computes voltages and currents as phasors. Phasors are complex numbers representing sinusoidal voltages and currents at a particular frequency. They can be expressed either in Cartesian coordinates (real and imaginary) or in polar coordinates (amplitude and phase). As the electrical states are ignored, the phasor solution method does not require a particular solver to solve the electrical part of your system. The simulation is therefore much faster to execute. You must keep in mind, however, that this faster solution technique gives the solution only at one particular frequency.

Phasor Simulation of a Circuit Transient

You now apply the phasor solution method to a simple linear circuit. Open the Demos library of **powerlib**. Open the General Demos library and select the demo named “Transient Analysis.” A system named `power_transient` opens.

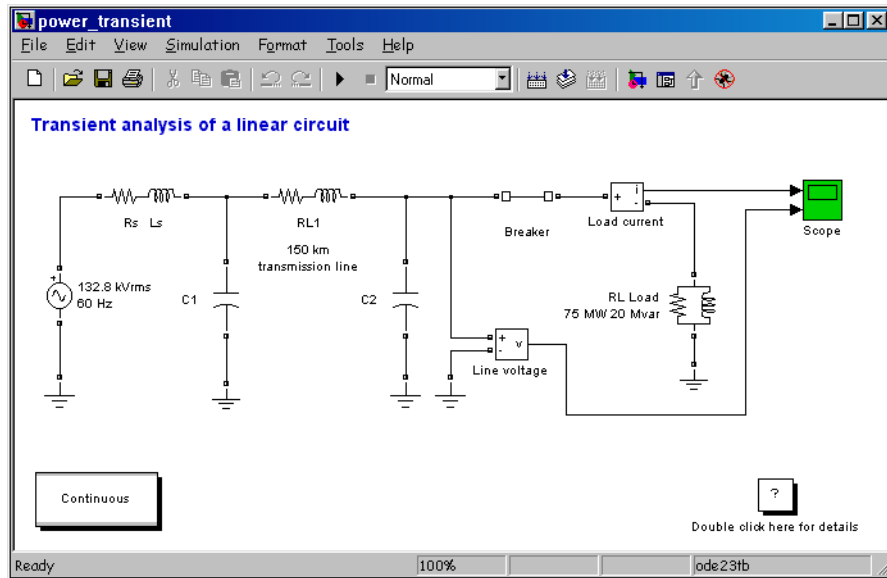

Simple Linear Circuit Built in SimPowerSystems

This circuit is a simplified model of a 60 Hz, 230 kV three-phase power system where only one phase is represented. The equivalent source is modeled by a voltage source (230 kV RMS / $\sqrt{3}$) or 132.8 kV RMS, 60 Hz) in series with its internal impedance ($R_s L_s$). The source feeds an RL load through a 150 km transmission line modeled by a single PI section (RL1 branch and two shunt capacitances, C1 and C2). A circuit breaker is used to switch the load (75 MW, 20 Mvar) at the receiving end of the transmission line. Two measurement blocks are used to monitor the load voltage and current.

The Powergui block at the lower-left corner indicates that the model is continuous. Start the simulation and observe transients in voltage and current waveforms when the load is first switched off at $t = 0.0333$ s (2 cycles) and switched on again at $t = 0.1167$ s (7 cycles).

Invoking the Phasor Solution in the Powergui Block

You now simulate the same circuit using the phasor simulation method. This option is accessible through the Powergui block. Open this block and select **Phasor simulation**. You must also specify the frequency used to solve the algebraic network equations. A default value of 60 Hz should already be entered in the **Frequency** menu. Close the Powergui and notice that the word Phasors now appears on the Powergui icon, indicating that the Powergui now applies this method to simulate your circuit. Before restarting the simulation, you need to specify the appropriate format for the two signals sent to the Scope block.

Selecting Phasor Signal Measurement Formats

If you now double-click the Voltage Measurement block or the Current Measurement block, you see that a menu allows you to output phasor signals in four different formats: Complex (default choice), Real-Imag, Magnitude-Angle, or just Magnitude. The Complex format is useful when you want to process complex signals. Note that the oscilloscope does not accept complex signals. Select Magnitude format for both the Line Voltage and the Load Current Measurement blocks. This will allow you to observe the magnitude of the voltage and current phasors.

Restart the simulation. The magnitudes of the 60 Hz voltage and current are now displayed on the scope. Waveforms obtained from the continuous simulation and the phasor simulation are superimposed in this plot.

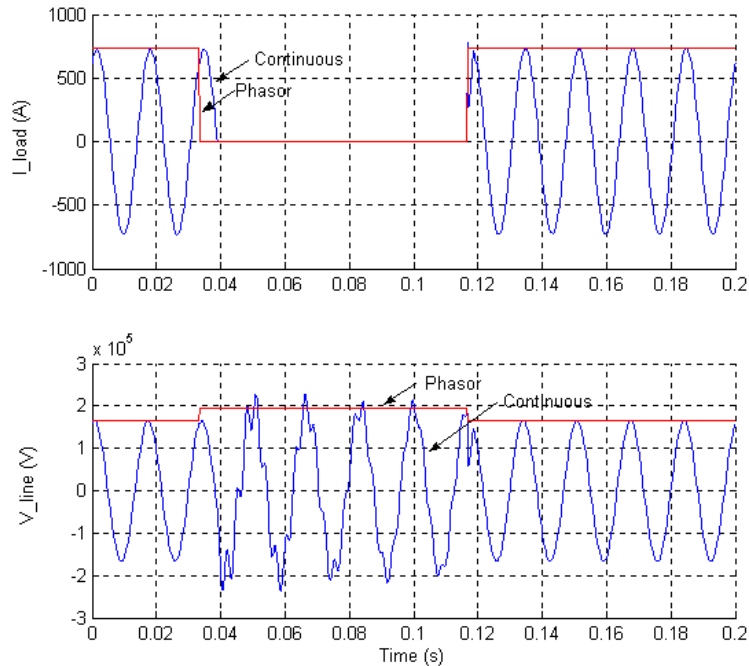

Waveforms Obtained with the Continuous and Phasor Simulation Methods

Note that with continuous simulation, the opening of the circuit breaker occurs at the next zero crossing of current following the opening order; whereas for the phasor simulation, this opening is instantaneous. This is because there is no concept of zero crossing in the phasor simulation.

Processing Voltage and Current Phasors

The Complex format allows the use of complex operations and processing of phasors without separating real and imaginary parts. Suppose, for example, that you need to compute the power consumption of the load (active power P and reactive power Q). The complex power S is obtained from the voltage and current phasors as

$$\bar{S} = P + jQ = \frac{1}{2} \cdot \bar{V} \cdot \bar{I}^*$$

where I^* is the conjugate of the current phasor. The $1/2$ factor is required to convert magnitudes of voltage and current from peak values to RMS values.

Select the Complex format for both current and voltage and, using blocks from the Simulink Math library, implement the power measurement as shown.

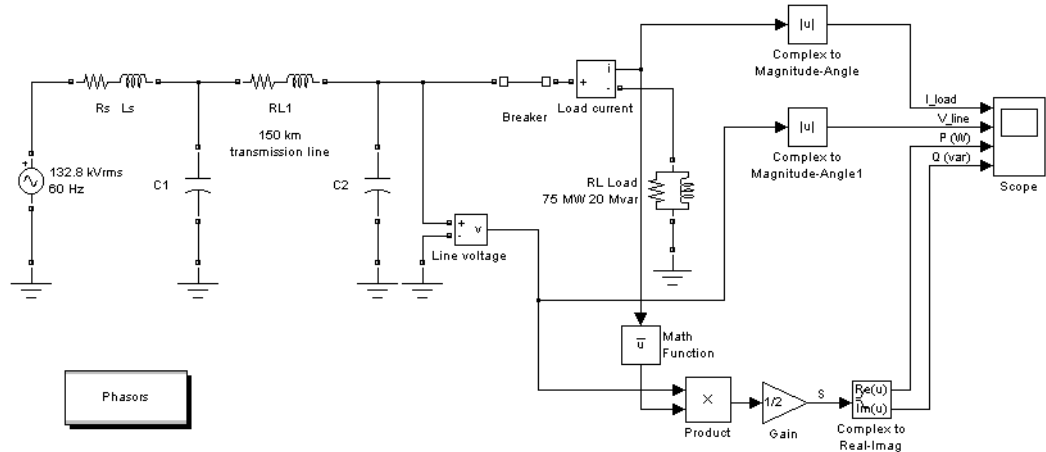

Power Computation Using Complex Voltage and Current

The Complex to Magnitude-Angle blocks are now required to convert complex phasors to magnitudes before sending them to the scope.

The power computation system you just implemented is already built into SimPowerSystems. The Active & Reactive Power (Phasor Type) block is available in the Extras library under the phasor collection of blocks.

Advanced Components and Techniques

This chapter introduces methods and devices that enhance your power system simulations and make them more realistic.

The first two tutorials illustrate power electronics, simple motors, and Fourier analysis. The third tutorial demonstrates three-phase power systems, electrical machinery, load flow, and use of the phasor solution method for transient stability studies of electromechanical systems. The fourth explains how you can create and customize your own nonlinear blocks.

Introducing Power Electronics
(p. 2-2)

Use power electronics and transformers and vary circuit initial conditions

Simulating Variable Speed Motor
Control (p. 2-10)

Model and discretize simple motors with specialized blocks. Use the FFT Analysis tool of the Powergui block to perform harmonic analysis

Three-Phase Systems and Machines
(p. 2-23)

Use electrical machines and three-phase components. Apply the phasor solution method to study of electromechanical oscillations of power systems

Building and Customizing
Nonlinear Models (p. 2-38)

Model nonlinear systems and create your own blocks to represent them

Building a Model Using Model
Construction Commands (p. 2-55)

Use model construction commands to add blocks to your models and connect them.

Introducing Power Electronics

In this section you

- Learn how to use power electronics components
- Learn how to use transformers
- Change initial conditions of a circuit

SimPowerSystems is designed to simulate power electronic devices. This section uses a simple circuit based on thyristors as the main example.

Consider the circuit shown below. It represents one phase of a static var compensator (SVC) used on a 735 kV transmission network. On the secondary of the 735 kV/16 kV transformer, two variable susceptance branches are connected in parallel: one thyristor-controlled reactor (TCR) branch and one thyristor-switched capacitor (TSC) branch.

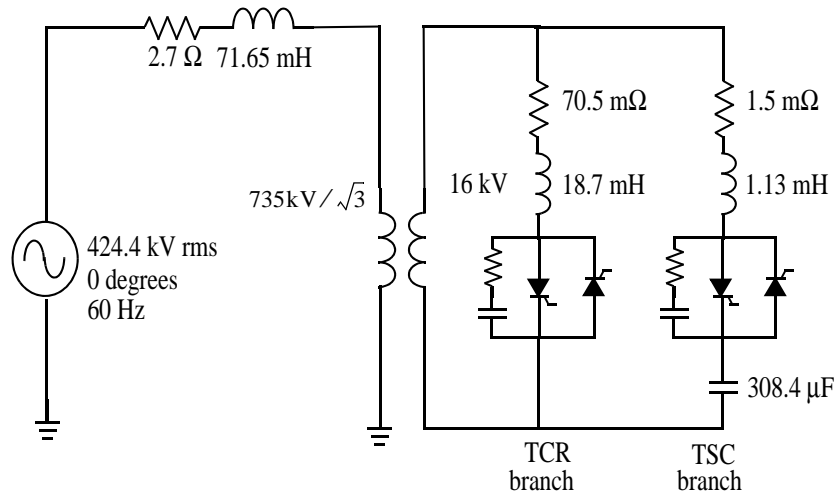
**Transformer parameters:**

Nominal power 110 MVA

Primary: Rated voltage 424.4 kV
 RMS leakage reactance = 0.15
 p.u. resistance = 0.002 p.u.

Secondary: Rated voltage 16 kV
 RMS leakage reactance = 0 p.u.
 resistance = 0.002 p.u.

Magnetizing current at 1 p.u.
 voltage: Inductive: 0.2%
 Resistive: 0.2%

Thyristor parameters:

$R_{on} = 1 \text{ m}\Omega$; $V_f = 14 \times 0.8 \text{ V}$

(14 thyristors in series)

Snubber: $R_s = 500 \Omega$; $C_s = 0.15 \mu\text{F}$

Figure 2-1: One Phase of a TCR/TSC Static Var Compensator

The TCR and TSC branches are both controlled by a valve consisting of two thyristor strings connected in antiparallel. An RC snubber circuit is connected across each valve. The TSC branch is switched on/off, thus providing discrete step variation of the SVC capacitive current. The TCR branch is phase controlled to obtain a continuous variation of the net SVC reactive current.

Now build two circuits illustrating the operation of the TCR and the TSC branches.

Simulation of the TCR Branch

- 1 Open a new window and save it as circuit3.
- 2 Open the Power Electronics library and copy the Thyristor block into your circuit3 model.
- 3 Open the **Thyristor** menu and set the parameters as follows:

Ron	1e-3
Lon	0
Vf	14*0.8
Rs	500
Cs	0.15e-6

Notice that the snubber circuit is integral to the **Thyristor** dialog box.

- 4 Rename this block Th1 and duplicate it.
- 5 Connect this new thyristor Th2 in antiparallel with Th1, as shown in Figure 2-2.

As the snubber circuit has already been specified with Th1, the snubber of Th2 must be eliminated.

- 6 Open the **Th2** dialog box and set the snubber parameters to

Rs	Inf
Cs	0

Notice that the snubber disappears on the Th2 icon.

The linear transformer is located in the Elements library. Copy it, rename it to TrA, and open its dialog box. Set its nominal power, frequency, and winding parameters (**winding 1** = primary; **winding 2** = secondary) as shown in Figure 2-1.

The Units parameter allows you to specify the resistance R and leakage inductance L of each winding as well as the magnetizing branch R_m/L_m , either in SI units (ohms, henries) or in per units (pu). Keep the default pu setting to specify directly R and L in per unit quantities. As there is no tertiary winding, deselect **Three windings transformer**. Winding 3 disappears on the TrA block.

Finally, set the magnetizing branch parameters **Rm** and **Xm** at [500, 500]. These values correspond to 0.2% resistive and inductive currents.

Add a voltage source, series RL elements, and a Ground block. Set the parameters as shown in Figure 2-1. Add a current measurement to measure the primary current. Interconnect the circuit as shown in Figure 2-2.

Notice that the Thyristor blocks have an output identified by the letter m . This output returns a Simulink vectorized signal containing the thyristor current (I_{ak}) and voltage (V_{ak}). Connect a Demux block with two outputs at the m output of Th1. Then connect the two demultiplexer outputs to a dual trace scope that you rename Scope_Th1. (To create a second input to your scope, in the **Scope properties** \rightarrow **General** menu item, set the number of axes to 2.) Label the two connection lines I_{th1} and V_{th1} . These labels are automatically displayed on the top of each trace.

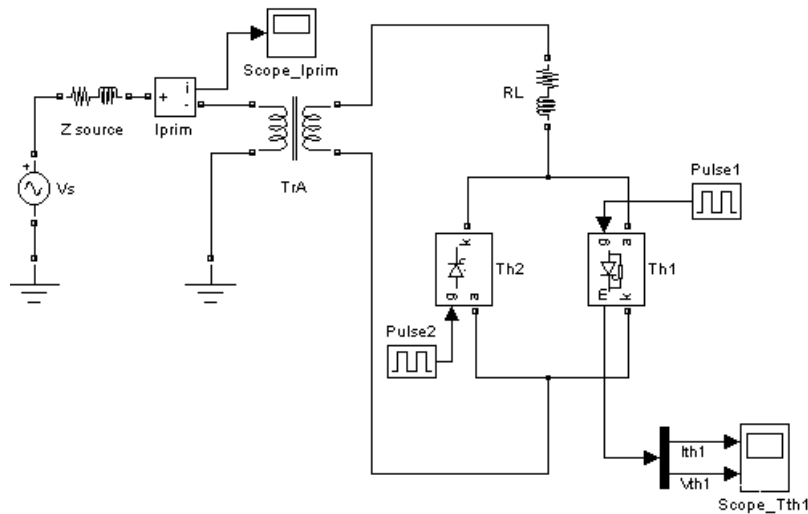

Figure 2-2: Simulation of the TCR Branch

You can now model the synchronized pulse generators firing thyristors Th1 and Th2. Copy two Simulink pulse generators into your system, name them Pulse1 and Pulse2, and connect them to the gates of Th1 and Th2.

Now you have to define the timing of the Th1 and Th2 pulses. At every cycle a pulse has to be sent to each thyristor α degrees after the zero crossing of the thyristor commutation voltage. Set the Pulse1 and Pulse2 parameters as follows:

Amplitude	1
Period	1/60 s
Pulse width (% of period)	1% (3.6 degrees pulses)
Phase Delay	1/60+T for Pulse1 1/60+1/120+T for Pulse2

The pulses sent to Th2 are delayed by 180 degrees with respect to pulses sent to Th1. The delay T is used to specify the firing angle α . To get a 120 degree firing angle, specify T in the workspace by entering

$$T = 1/60/3;$$

Now open the **Simulation** → **Simulation parameters** dialog box. Select the ode23t integration algorithm. Keep the default parameters but set the relative tolerance to $1e-4$ and the stop time to 0.1.

Add a Powergui block at the top level of your model, then start the simulation. The results are shown in Figure 2-3.

Note You could also choose to discretize your system. Try, for example, a sample time of 50 μ s. The simulation results should compare well with the continuous system.

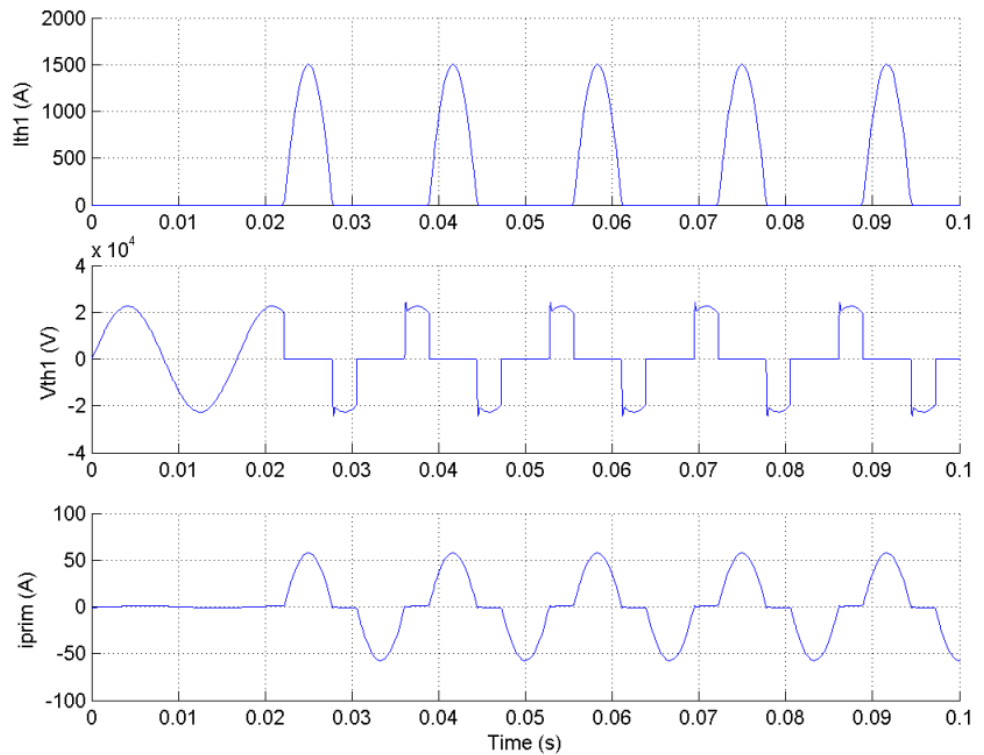

Figure 2-3: TCR Simulation Results

Simulation of the TSC Branch

You can now modify your `circuit3` system and change the TCR branch to a TSC branch. Save `circuit3` as a new system and name it `circuit4`.

Connect a capacitor in series with the RL inductor and Th1/Th2 valve as shown in the figure below. Change the **R**, **L**, and **C** parameters as shown in Figure 2-1. Connect a voltmeter and scope to monitor the voltage across the capacitor.

Contrary to the TCR branch, which was fired by a synchronous pulse generator, a continuous firing signal is now applied to the two thyristors. Delete the two pulse generators. Copy a Step block from the Simulink library and connect its output at both gates of Th1 and Th2. Set its step time at 1/60/4

(energizing at the first positive peak of the source voltage). Your circuit should now be similar to the one shown here.

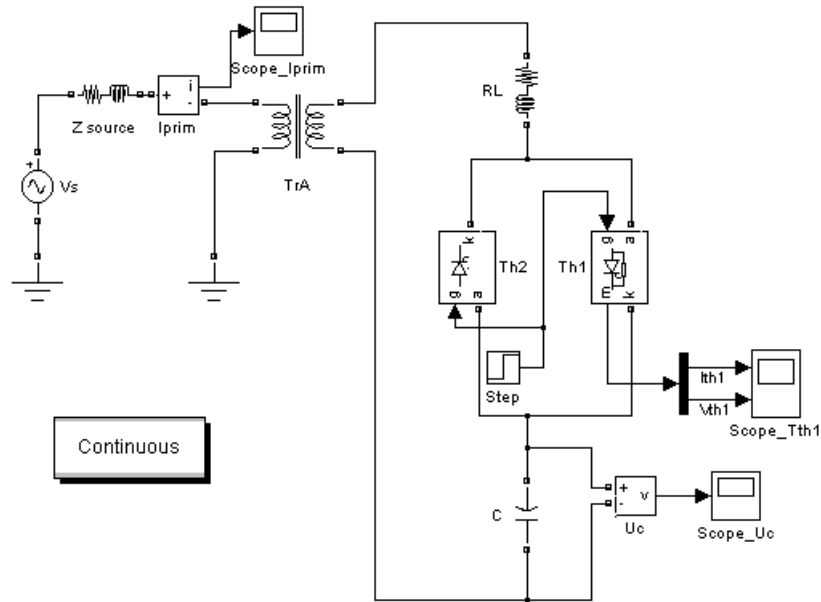

Simulation of the TSC Branch

Open the three scopes and start the simulation.

As the capacitor is energized from zero, you can observe a low damping transient at 200 Hz, superimposed with the 60 Hz component in the capacitor voltage and primary current. During normal TSC operation, the capacitor has an initial voltage left since the last valve opening. To minimize the closing transient with a charged capacitor, the thyristors of the TSC branch must be fired when the source voltage is at maximum value and with the correct polarity. The initial capacitor voltage corresponds to the steady-state voltage obtained when the thyristor switch is closed. The capacitor voltage is 17.67 kVrms when the valve is conducting. At the closing time, the capacitor must be charged at the peak voltage.

$$U_c = 17670 \times \sqrt{2} = 24989 \text{ V}$$

You can now use the Powergui block to change the capacitor initial voltage. Open the Powergui and select **Initial States Setting**. A list of all the state variables with their default initial values appears. The value of the initial voltage across the capacitor C (variable Uc_C) should be -0.3141 V. This voltage is not exactly zero because the snubber allows circulation of a small current when both thyristors are blocked. Now select the Uc_C state variable and enter 24989 in the upper right field. Then click the **Apply** button to make this change effective.

Start the simulation. As expected the transient component of capacitor voltage and current has disappeared. The voltages obtained with and without initial voltage are compared in this plot.

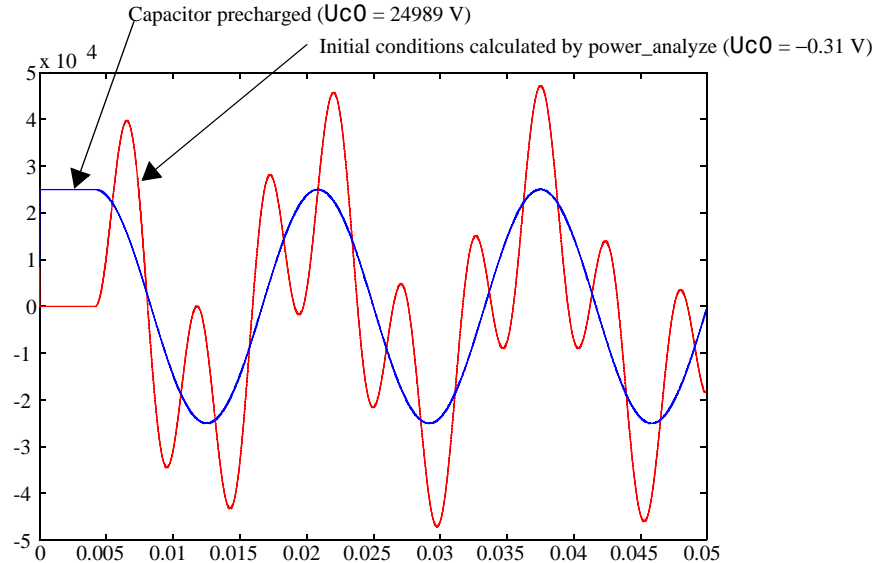

Transient Capacitor Voltage With and Without Initial Charge

Simulating Variable Speed Motor Control

In this section you

- Use electrical machines and power electronics to simulate a simple AC motor drive with variable speed control
- Learn how to use the Universal Bridge block
- Discretize your model and compare variable-step and fixed-step simulation methods
- Learn how to use the Multimeter block
- Learn how to use the FFT tool

Variable speed control of AC electrical machines makes use of forced-commutated electronic switches such as IGBTs, MOSFETs, and GTOs. Asynchronous machines fed by *pulse width modulation* (PWM) voltage sourced converters (VSC) are nowadays gradually replacing the DC motors and thyristor bridges. With PWM, combined with modern control techniques such as field-oriented control or direct torque control, you can obtain the same flexibility in speed and torque control as with DC machines. This section shows how to build a simple open loop AC drive controlling an asynchronous machine. Chapter 4 will introduce you to a specialized library containing 13 models of DC and AC drives. These “ready to use” models will enable you to simulate electric drive systems without the need to build those complex systems yourself.

The Machines library contains four of the most commonly used three-phase machines: simplified and complete synchronous machines, asynchronous machine, and permanent magnet synchronous machine. Each machine can be used either in generator or motor mode. Combined with linear and nonlinear elements such as transformers, lines, loads, breakers, etc., they can be used to simulate electromechanical transients in an electrical network. They can also be combined with power electronic devices to simulate drives.

The Power Electronics library contains blocks allowing you to simulate diodes, thyristors, GTO thyristors, MOSFETs, and IGBT devices. You could interconnect several blocks together to build a three-phase bridge. For example, an IGBT inverter bridge would require six IGBTs and six antiparallel diodes.

To facilitate implementation of bridges, the Universal Bridge block automatically performs these interconnections for you.

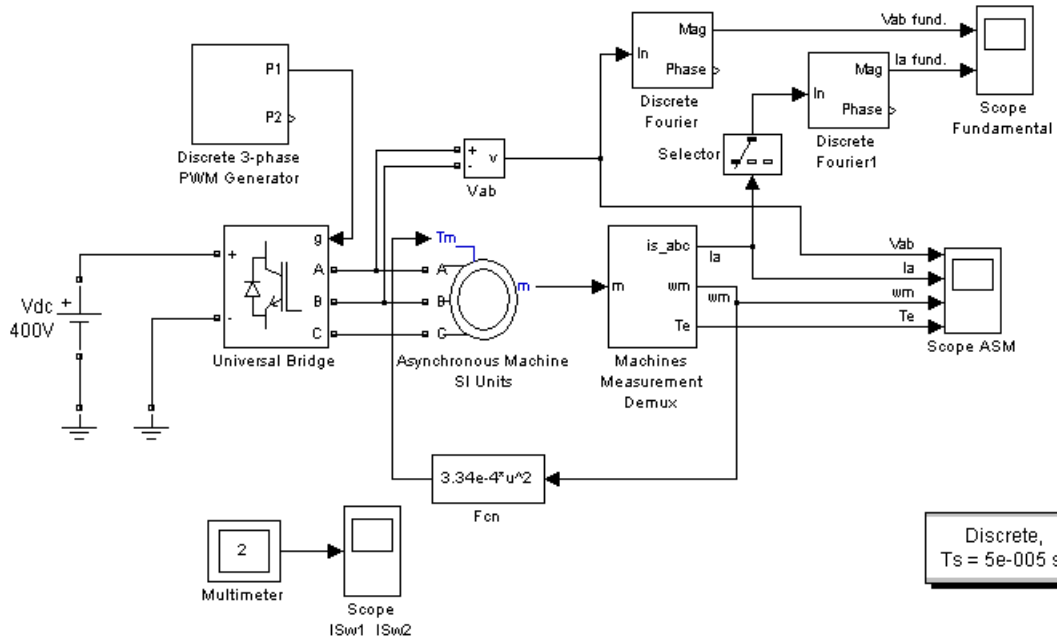

Figure 2-4: Circuit 5: PWM Control of an Induction Motor

Building and Simulating the PWM Motor Drive

Follow these steps to build a PWM-controlled motor.

Assembling and Configuring the Motor Blocks

In the first steps, you copy and set up the motor blocks:

- 1 Open a new window and save it as circuit5.

- 2 Open the Power Electronics library and copy the Universal Bridge block into your circuit5 model.
- 3 Open the Universal Bridge dialog box and set its parameters as follows:

Power electronic device IGBT/Diodes

Snubber

Rs	1e5 Ω
Cs	inf
Ron	1e-3 Ω

Forward voltages

Vf	0 V
Vfd	0 V

Tail

Tf	1e-6 s
Tt	1e-6 s

Notice that the snubber circuit is integral to the Universal Bridge dialog box. As the Cs capacitor value of the snubber is set to Inf (short-circuit), we are using a purely resistive snubber. Generally, IGBT bridges do not use snubbers; however, because each nonlinear element in SimPowerSystems is modeled as a current source, you have to provide a parallel path across each IGBT to allow connection to an inductive circuit (stator of the asynchronous machine). The high resistance value of the snubber does not affect the circuit performance.

- 4 Open the Machines library. Copy the Asynchronous Machine SI Units block as well as the Machine Measurement Demux block into your circuit5 model.
- 5 Open the Asynchronous Machine menu and look at its parameters. Set the nominal power Pn parameter to 3*746 VA and the nominal line-to-line voltage Vn to 220 Vrms to implement a 3 HP, 60 Hz machine with two pairs of poles. Its nominal speed is therefore slightly lower than the synchronous speed of 1800 rpm, or $\omega_s = 188.5$ rad/s.

- 6 Notice that the three rotor terminals a, b, and c are made accessible. During normal motor operation these terminals should be short-circuited together. In the Asynchronous Machine menu change the rotor type to **Squirrel cage**. Notice that after this change the rotor connections are no longer accessible.
- 7 Open the Machine Measurement Demux block menu. When this block is connected to a machine measurement output, it allows you to access specific internal signals of the machine. First select the **Asynchronous** machine type. Deselect all signals except the following three signals: `is_abc` (three stator currents), `wm` (rotor speed), and `Te` (electromagnetic torque).

Loading and Driving the Motor

You now implement the torque-speed characteristic of the motor load. Assume a quadratic torque-speed characteristic (fan or pump type load). The torque T is then proportional to the square of the speed ω .

$$T = k \times \omega^2$$

The nominal torque of the motor is

$$T_n = \frac{3 \times 746}{188.5} = 11.87 Nm$$

Therefore, the constant k should be

$$k = \frac{T_n}{\omega_s^2} = \frac{11.87}{188.5^2} = 3.34 \times 10^{-4}$$

- 1 Open the Math Operations library of Simulink and copy the Math Function block into your `circuit5` model. Open the block menu and enter the expression of torque as a function of speed: `3.34e-4*u^2`.
- 2 Connect the input of the Math Function block to the speed output of the Machines Measurement Demux block, labeled `wm`, and its output to the torque input of the motor, labeled `Tm`.
- 3 Open the Electrical Sources library and copy the DC Voltage Source block into your `circuit5` model. Open the block menu and set the voltage to 400 V.

- 4 Open the Measurements library and copy a Voltage Measurement block into your `circuit5` model. Change the block name to `Vab`.
- 5 Using Ground blocks from the Elements library, complete the power elements and voltage sensor interconnections as shown in Figure 2-4.

Controlling the Inverter Bridge with a Pulse Generator

To control your inverter bridge, you need a pulse generator. Such a generator is available in the Extras library of **powerlib**:

- 1 Open the Extras/Discrete Control blocks library and copy the Discrete 3-Phase PWM Generator block into your `circuit5` model. This block can be used to generate pulses for a two-level or a three-level bridge. In addition the block generates two sets of pulses (outputs P1 and P2) that can be sent to two different three-arm bridges when the converter uses a twin bridge configuration. In this case, use it as a two-level single-bridge PWM generator. The converter operates in an open loop, and the three PWM modulating signals are generated internally. Connect the P1 output to the pulses input of the Universal Bridge block
- 2 Open the Discrete Three-Phase PWM Generator block dialog box and set the parameters as follows.

Type	2 level
Mode of operation	Un-synchronized
Carrier frequency	18*60Hz (1080 Hz)
Internal generation of modulating signals	selected
Modulation index m	0.9
Output voltage frequency	60 Hz
Output voltage phase	0 degrees
Sample time	10e-6 s

- 3 Use the **Edit** —> **Look Under Mask** menu item of your model window to see how the PWM is implemented. This control system is made entirely with Simulink blocks. The block has been discretized so that the pulses change at

multiples of the specified time step. A time step of 10 μs corresponds to $\pm 0.54\%$ of the switching period at 1080 Hz.

One common method of generating the PWM pulses uses comparison of the output voltage to synthesize (60 Hz in this case) with a triangular wave at the switching frequency (1080 Hz in this case). This is the method that is implemented in the Discrete 3-Phase PWM Generator block. The line-to-line RMS output voltage is a function of the DC input voltage and of the modulation index m as given by the following equation:

$$V_{LLrms} = \frac{m}{2} \times \frac{\sqrt{3}}{\sqrt{2}} V_{dc} = m \times 0.612 \times V_{DC}$$

Therefore, a DC voltage of 400 V and a modulation factor of 0.90 yield the 220 Vrms output line-to-line voltage, which is the nominal voltage of the asynchronous motor.

Displaying Signals and Measuring Fundamental Voltage and Current

- 1 You now add blocks measuring the fundamental component (60 Hz) embedded in the chopped Vab voltage and in the phase A current. Open the Extras/Discrete Measurements library of **powerlib** and copy the discrete Fourier block into your circuit5 model.

Open the discrete Fourier block dialog box and check that the parameters are set as follows:

Fundamental frequency f1	60 Hz
Harmonic number	1
Initial input	[0 0]
Sample time	10e-6 s

Connect this block to the output of the Vab voltage sensor.

- 2 Duplicate the Discrete Fourier block. To measure the phase A current, you need to select the first element of the `is_abc` output of the ASM Measurement Demux block.

Copy a Selector block from the Signals & Systems library of Simulink.

Open its menu and set **Element** to 1. Connect the Selector output to the second Discrete Fourier block and its input to the `is_abc` output of the Machines Measurement Demux block as shown in Figure 2-4.

- 3 Finally, add scopes to your model. Copy one Scope block into your circuit. This scope is used to display the instantaneous motor voltage, currents, speed, and electromagnetic torque. In the **Scope Properties** → **General** menu of the scope, set the following parameters:

Number of axes	4
Time range	0.05 s
Tick labels	bottom axis only

Connect the four inputs and label the four connection lines as shown in Figure 2-3. When you start the simulation, these labels are displayed on top of each trace.

To allow further processing of the signals displayed on the oscilloscope, you have to store them in a variable. In the **Scope Parameters/Data history** menu of the scope, set the following parameters:

Limit data point to last	deselected
Save data to workspace	selected
variable name	ASM
Format	Structure with time

After simulation, the four signals displayed on the scope are available in a structure array named ASM.

- 4 Duplicate the four-input Scope and change its number of inputs to 2. This scope is used to display the fundamental component of Vab voltage and Ia

current. Connect the two inputs to the outputs of the Fourier blocks. Label the two connection lines as shown in Figure 2-3.

You are now ready to simulate the motor starting.

Simulating the PWM Motor Drive with Continuous Integration Algorithm

Open the **Simulation** → **Simulation parameters** menu. Select the ode23t integration algorithm. Set the relative tolerance to $1e-4$, the absolute tolerance and the Max step size to auto, and the stop time to 1 s. Start the simulation. The simulation results are shown in Figure 2-5.

The motor starts and reaches its steady-state speed of 181 rad/s (1728 rpm) after 0.5 s. At starting, the magnitude of the 60 Hz current reaches 90 A peak (64 A RMS) whereas its steady-state value is 10.5 A (7.4 A RMS). As expected, the magnitude of the 60 Hz voltage contained in the chopped wave stays at

$$220 \times \sqrt{2} = 311V$$

Also notice strong oscillations of the electromagnetic torque at starting. If you zoom in on the torque in steady state, you should observe a noisy signal with a mean value of 11.9 N.m, corresponding to the load torque at nominal speed.

If you zoom in on the three motor currents, you can see that all the harmonics (multiples of the 1080 Hz switching frequency) are filtered by the stator inductance, so that the 60 Hz component is dominant.

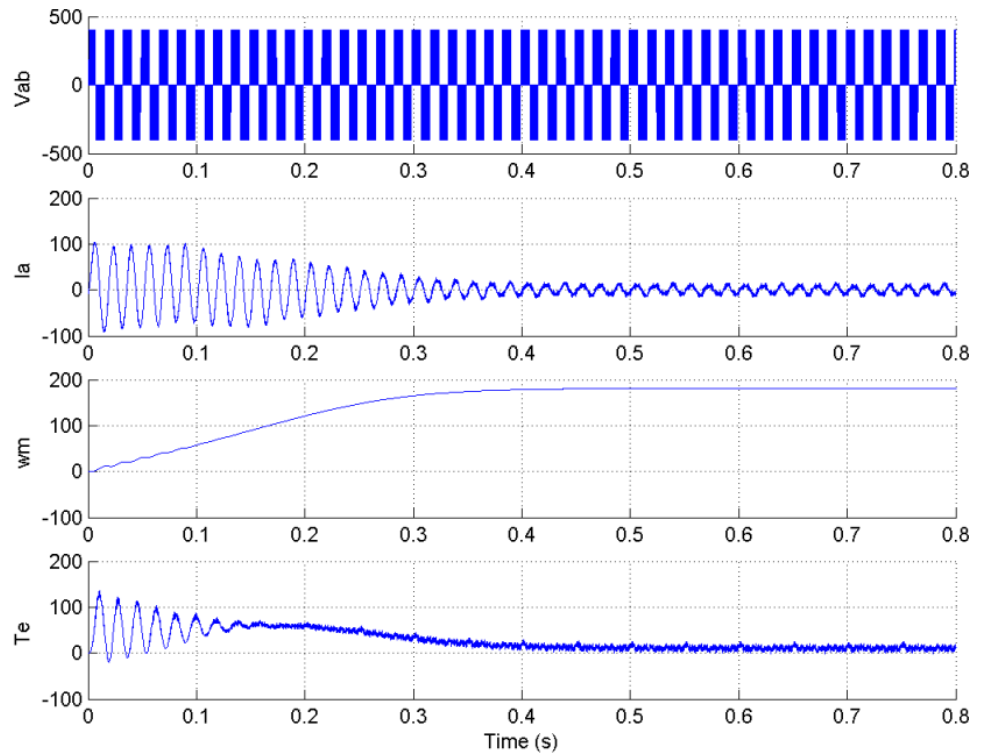

Figure 2-5: PWM Motor Drive; Simulation Results for Motor Starting at Full Voltage

Using the Multimeter Block

The Universal Bridge block is not a conventional subsystem where all the six individual switches are accessible. If you want to measure the switch voltages and currents, you must use the Multimeter block, which gives access to the bridge internal signals:

- 1 Open the **Universal Bridge** dialog box and set the **Measurement** parameter to Device currents.

- 2** Copy the Multimeter block from the Measurements library into your circuit5 circuit. Double-click the Multimeter block. A window showing the six switch currents appears.
- 3** Select the two currents of the bridge arm connected to phase A. They are identified as
 - iSw1** Universal Bridge
 - iSw2** Universal Bridge
- 4** Click **OK**. The number of signals (2) is displayed in the multimeter icon.
- 5** Using a Demux block, send the two multimeter output signals to a two-trace scope and label the two connection lines (Trace 1: iSw1 Trace 2: iSw2).
- 6** Restart the simulation. The waveforms obtained for the first 20 ms are shown in this plot.

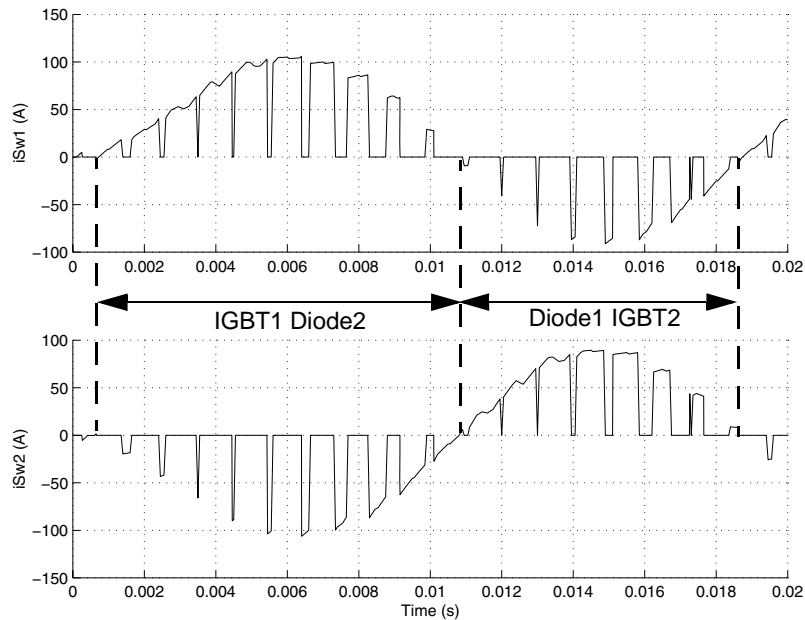

Currents in IGBT/Diode Switches 1 and 2

As expected, the currents in switches 1 and 2 are complementary. A positive current indicates a current flowing in the IGBT, whereas a negative current indicates a current in the antiparallel diode.

Note Multimeter block use is not limited to the Universal Bridge block. Many blocks of the Electrical Sources and Elements libraries have a Measurement parameter where you can select voltages, currents, or saturable transformer fluxes. A judicious use of the Multimeter block reduces the number of current and voltage sensors in your circuit, making it easier to follow.

Discretizing the PWM Motor Drive

You might have noticed that the simulation using a variable-step integration algorithm is relatively long. Depending on your computer, it might take tens of seconds to simulate one second. To shorten the simulation time, you can discretize your circuit and simulate at fixed simulation time steps.

Open the Powergui and select **Discretize electrical model**. Set the **Sample Time** to $10e-6$ s. When you restart the simulation, the power system, including the asynchronous machine, is discretized at a $10\ \mu\text{s}$ sample time.

As there are no more continuous states in the electrical system, you do not need a variable-step integration method to solve this system. In the **Simulation** → **Simulation parameters** → **Solver** dialog box pane, select the Fixed-step and discrete (no continuous states) options.

Start the simulation. Observe that the simulation is now approximately three times faster than with the continuous system. Results compare well with the continuous system.

Performing Harmonic Analysis Using the FFT Tool

The two Discrete Fourier blocks allow computation of the fundamental component of voltage and current while simulation is running. If you would like to observe harmonic components also you would need a Discrete Fourier block for each harmonic. This approach is not convenient.

Now use the FFT tool of Powergui to display the frequency spectrum of voltage and current waveforms. These signals are stored in your workspace in the ASM

structure with time variable generated by the Scope block. Because your model is discretized, the signal saved in this structure is sampled at a fixed step and consequently satisfies the FFT tool requirements.

Open the Powergui and select **FFT Analysis**. A new window opens. Set the parameters specifying the analyzed signal, the time window, and the frequency range as follows:

Structure	ASM
Input	Vab
Signal number	1
Start time	0.7 s
Number of cycles	2
(pull-down menu)	Display FFT window
Fundamental frequency	60 Hz
Max Frequency	5000 Hz
Frequency axis	Harmonic order
Display style	Bar (relative to Fund or DC)

The analyzed signal is displayed in the upper window. Click **Display**. The frequency spectrum is displayed in the bottom window, as shown in the next figure.

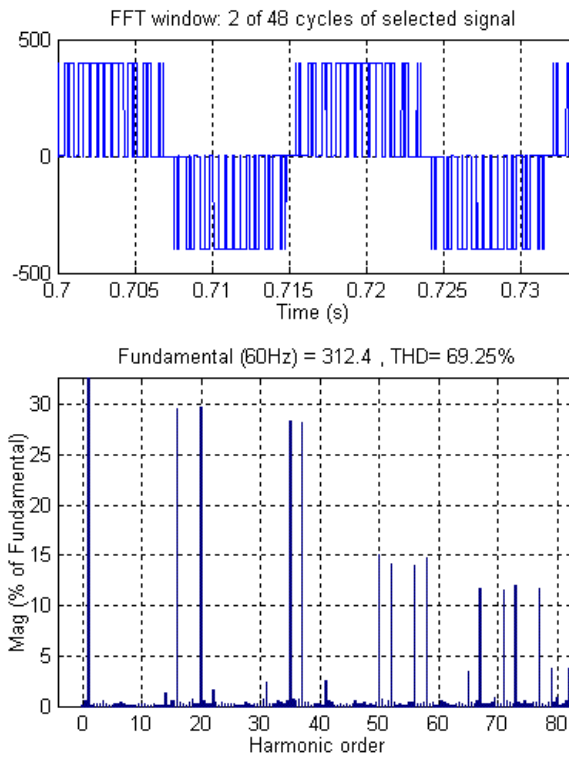

FFT Analysis of the Motor Line-to-Line Voltage

The fundamental component and *total harmonic distortion* (THD) of the V_{ab} voltage are displayed above the spectrum window. The magnitude of the fundamental of the inverter voltage (312 V) compares well with the theoretical value (311 V for $m=0.9$).

Harmonics are displayed in percent of the fundamental component. As expected, harmonics occur around multiples of carrier frequency ($n \cdot 18 \pm k$). Highest harmonics (30%) appear at 16th harmonic ($18 - 2$) and 20th harmonic ($18 + 2$). Note that the THD value (69%) has been computed for the specified 0 to 5000 Hz frequency range. If you recompute the FFT with a maximum frequency range of 10000 Hz, you should see the THD increasing to 74% (5% contribution in THD for the 5000 to 10000 Hz frequencies).

Finally, select input I_a instead of V_{ab} and display its current spectrum.

Three-Phase Systems and Machines

In this section you

- Learn how to simulate a three-phase power system containing electrical machines and other three-phase models
- Perform a load flow study and initialize machines to start simulation in steady state by using the **Load Flow and Machine Initialization** option of the Powergui
- Simulate the power system and observe its dynamic performance by using both the standard solution technique using a continuous solver and the **Phasor Solution** method

You now use three types of machines of the Electrical Machines library: simplified synchronous machine, detailed synchronous machine, and asynchronous machine. You interconnect these machines with linear and nonlinear elements such as transformers, loads, and breakers to study the transient stability of an uninterruptible power supply using a diesel generator.

Three-Phase Network with Electrical Machines

The two-machine system shown in this single line diagram is this section's main example:

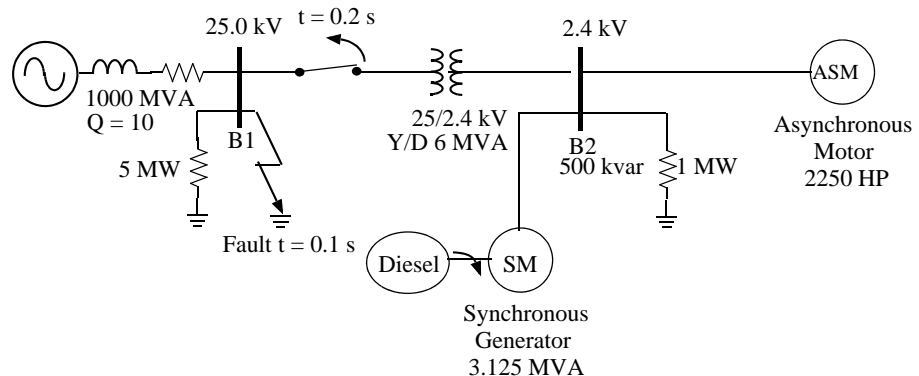

Figure 2-6: Diesel Generator and Asynchronous Motor on Distribution Network

This system consists of a plant (bus B2), simulated by a 1 MW resistive load and a motor load (ASM) fed at 2400 V from a distribution 25 kV network through a 6 MVA, 25/2.4 kV transformer, and from an emergency synchronous generator/diesel engine unit (SM).

The 25 kV network is modeled by a simple R-L equivalent source (short-circuit level 1000 MVA, quality factor $X/R = 10$) and a 5 MW load. The asynchronous motor is rated 2250 HP, 2.4 kV, and the synchronous machine is rated 3.125 MVA, 2.4 kV.

Initially, the motor develops a mechanical power of 2000 HP and the diesel generator is in standby, delivering no active power. The synchronous machine therefore operates as a synchronous condenser generating only the reactive power required to regulate the 2400 V bus B2 voltage at 1.0 p.u. At $t = 0.1$ s, a three-phase to ground fault occurs on the 25 kV system, causing the opening of the 25 kV circuit breaker at $t = 0.2$ s, and a sudden increase of the generator loading. During the transient period following the fault and islanding of the motor-generator system, the synchronous machine excitation system and the diesel speed governor react to maintain the voltage and speed at a constant value.

This system is modeled in a SimPowerSystems demo. Open the Demos library of **powerlib** and double-click the demo called “Three-Phase Machines and Load Flow.” A system named `power_machines` opens.

Emergency Diesel-Generator and Asynchronous Motor

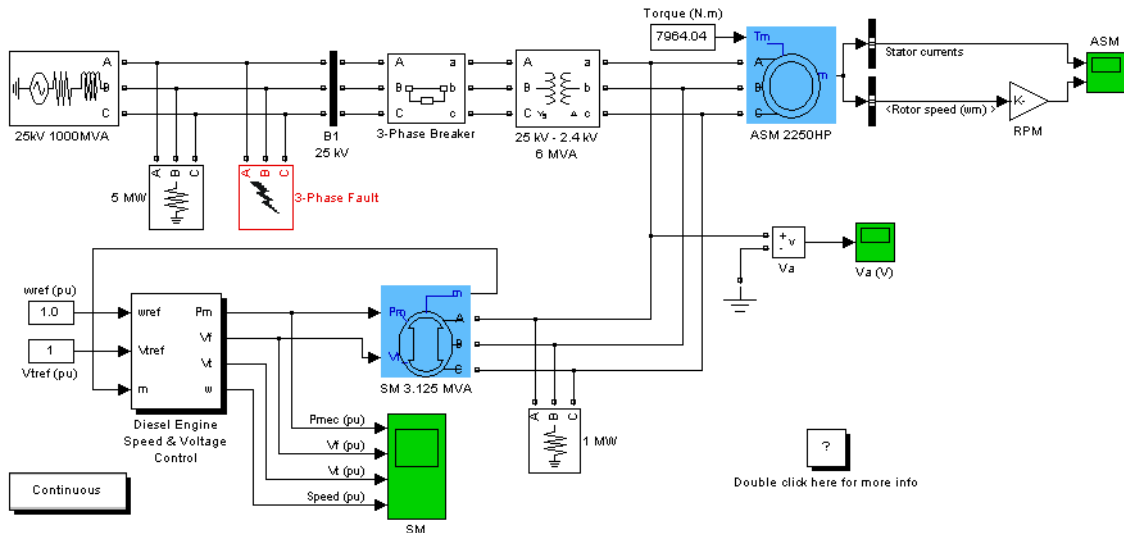
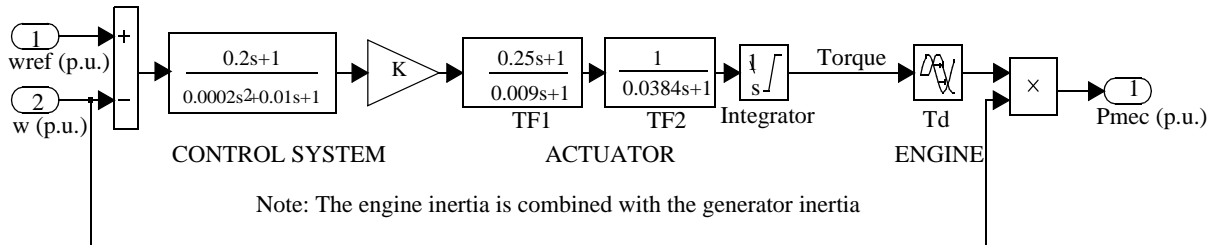

Figure 2-7: Power System of Figure 2-6 Built with SimPowerSystems

The Synchronous Machine (SM) block uses standard parameters, whereas the Asynchronous Machine (ASM) block uses SI parameters.

The other three-phase elements such as the inductive voltage source, the Y grounded/Delta transformer, and the loads are standard blocks from the Electrical Source and Elements libraries of **powerlib**. If you open the dialog box of the Three-Phase Fault and Three-Phase Breaker blocks, you see how the switching times are specified. The Machine Measurement Demux block provided in the Machines library is used to demux the output signals of the SM and ASM machines.

The SM voltage and speed outputs are used as feedback inputs to a Simulink control system that contains the diesel engine and governor block as well as an excitation block. The excitation system is the standard block provided in the Machines library. The SM parameters as well as the diesel engine and governor models were taken from reference [1].



Diesel Engine and Governor System

If you simulate this system for the first time, you normally do not know what the initial conditions are for the SM and ASM to start in steady state.

These initial conditions are

- SM block: Initial values of speed deviation (usually 0%), rotor angle, magnitudes and phases of currents in stator windings, and initial field voltage required to obtain the desired terminal voltage under the specified load flow
- ASM block: Initial values of slip, rotor angle, magnitudes and phases of currents in stator windings

Open the dialog box of the Synchronous Machine and Asynchronous Machine blocks. All initial conditions should be set at 0, except for the initial SM field voltage and ASM slip, which are set at 1 p.u. Open the three scopes monitoring the SM and ASM signals as well as the bus B2 voltage. Start the simulation and observe the first 100 ms before fault is applied.

As the simulation starts, note that the three ASM currents start from zero and contain a slowly decaying DC component. The machine speeds take a much longer time to stabilize because of the inertia of the motor/load and diesel/generator systems. In our example, the ASM even starts to rotate in the wrong direction because the motor starting torque is lower than the applied load torque. Stop the simulation.

Load Flow and Machine Initialization

To start the simulation in steady state with sinusoidal currents and constant speeds, all the machine states must be initialized properly. This is a difficult task to perform manually, even for a simple system. In the next section you learn how to use the **Load Flow and Machine Initialization** option of the Powergui block to perform a load flow and initialize the machines.

Double-click the Powergui block. In the **Tools** menu, click the **Load Flow and Machine Initialization** button. A new window appears. In the upper right window you have a list of the machines appearing in your system. Select the SM 3.125 MVA machine. Note that for the **Bus Type**, you have a menu allowing you to choose either PV Generator, PQ Generator, or Swing Generator.

For synchronous machines you normally specify the desired terminal voltage and the active power that you want to generate (positive power for generator mode) or absorb (negative power for motor mode). This is possible as long as you have a *swing* (or *slack*) bus that generates or absorbs the excess power required to balance the active powers throughout the network.

The swing bus can be either a voltage source or any other synchronous machine. If you do not have any voltage source in your system, you must declare one of the machines as a swing machine. In the next section, you perform a load flow with the 25 kV voltage source connected to bus B1, which is used as a swing bus.

Load Flow Without a Swing Machine

In the **Load Flow** window, your SM **Bus Type** should already be initialized as P & V generator, indicating that the load flow is performed with the machine controlling its active power and terminal voltage. By default, the desired **Terminal Voltage UAB** is initialized at the nominal machine voltage (2400 Vrms). Keep it unchanged and set the **Active Power** to zero. The synchronous machine therefore absorbs or generates reactive power only to keep terminal voltage at 1 p.u. Now select the ASM 2250 HP machine in the upper right window. The only parameter that is needed is the **Mechanical power** developed by the motor. Enter 2000×746 (2000 HP). You now perform the load flow with the following parameters.

SM

Terminal Voltage 2400 Vrms

Active Power 0 kW

ASM

Mechanical Power 2000*746 W (2000 HP)

Click the **Update Load Flow** button. Once the load flow is solved, the three phasors of line-to-line machine voltages as well as currents are updated as shown on the next figure. Values are displayed both in SI units (volts RMS or amperes RMS) and in p.u.

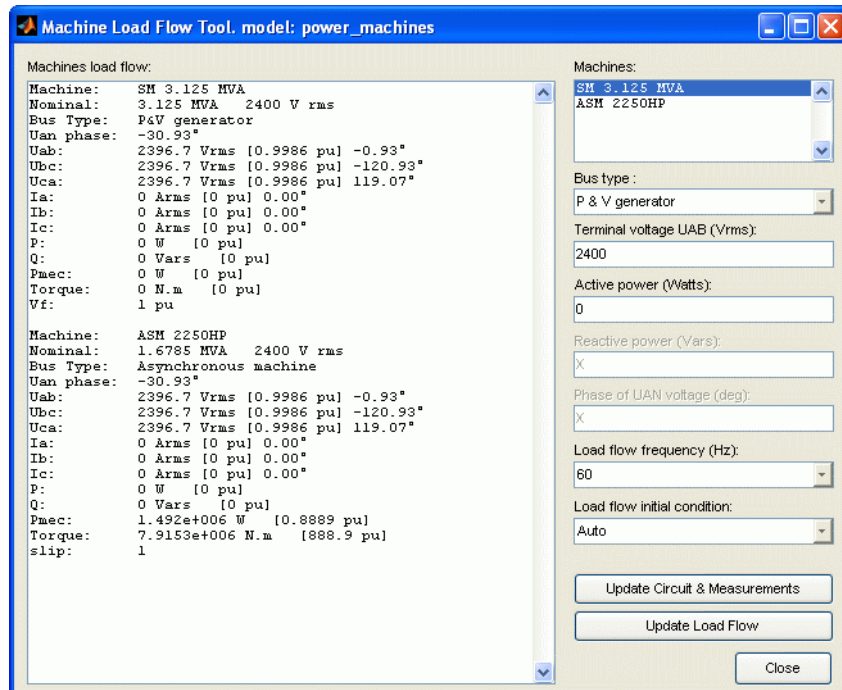

The SM active and reactive powers, mechanical power, and field voltage are displayed.

P 0 W

Q 856 kvar or $856/3125 = 0.2739$ p.u.

Pmec	844.2 W or 0.00027 p.u. , representing internal machine losses in stator windings
Ef (field voltage)	1.427 p.u.

The ASM active and reactive powers absorbed by the motor, slip, and torque are also displayed.

P	1.515 MW (0.9024 p.u.)
Q	615 kvar (0.3662 p.u.)
Pmec	1.492 MW (2000 HP)
Slip	0.006119
Torque	7964 N.m (0.8944 p.u.)

Close the **Load Flow** window.

The ASM torque value (7964 N.m) should already be entered in the Constant block connected at the ASM torque input. If you now open the **SM** and **ASM** dialog boxes you can see the updated initial conditions. If you open the Powergui, you can see updated values of the measurement outputs. You can also click the **Nonlinear** button to obtain voltages and currents of the nonlinear blocks. For example, you should find that the magnitude of the Phase A voltage across the fault breaker (named Uc_3-Phase Fault/Breaker1) is 14.42 kV RMS, corresponding to a 24.98 kV RMS phase-to-phase voltage.

To start the simulation in steady state, the states of the Governor & Diesel Engine and the Excitation blocks should also be initialized according to the values calculated by the load flow. Open the Governor & Diesel Engine subsystem, which is inside the Diesel Engine Speed and Voltage Control subsystem. Notice that the initial mechanical power has been automatically set to 0.0002701 p.u. Open the Excitation block and notice that the initial terminal voltage and field voltage have been set respectively to 1.0 and 1.427 p.u.

Note that the load flow also initializes the Constant blocks connected at the reference inputs (wref and vref) of the Governor and Excitation blocks as well as the Constant block connected at the load torque input (Tm) of the Asynchronous Machine block.

Open the three scopes displaying the internal signals of synchronous and asynchronous machines and phase A voltage. Start the simulation. The simulation results are shown in the following figure.

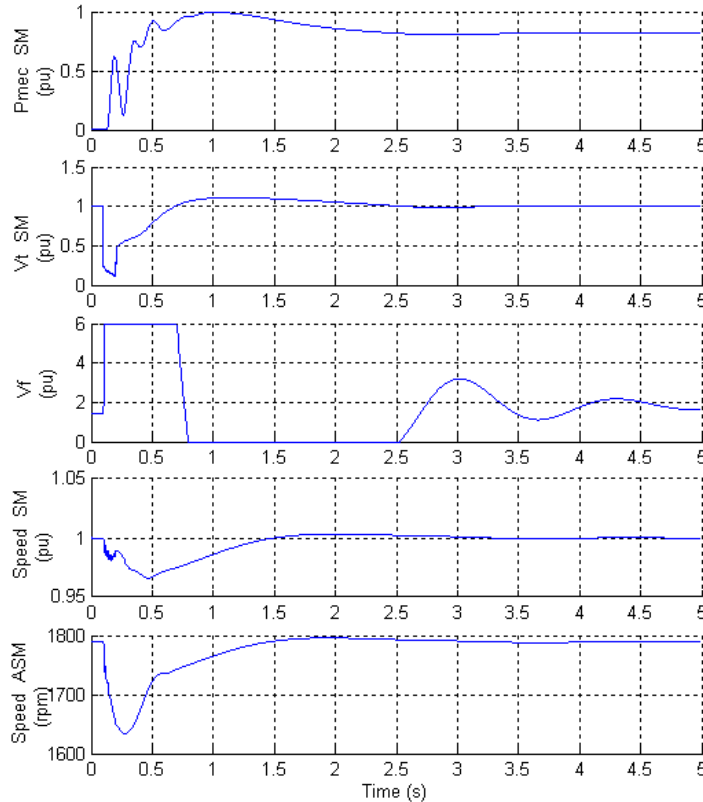

Figure 2-8: Simulation Results

Observe that during the fault, the terminal voltage drops to about 0.2 p.u., and the excitation voltage hits the limit of 6 p.u. After fault clearing and islanding, the SM mechanical power quickly increases from its initial value of 0 p.u. to 1 p.u. and stabilizes at the final value of 0.82 p.u. required by the resistive and motor load ($1.0 \text{ MW resistive load} + 1.51 \text{ MW motor load} = 2.51 \text{ MW} = 2.51/3.125 = 0.80 \text{ p.u.}$). After 3 seconds the terminal voltage stabilizes close to

its reference value of 1.0 p.u. The motor speed temporarily decreases from 1789 rpm to 1635 rpm, then recovers close to its normal value after 2 seconds.

If you increase the fault duration to 12 cycles by changing the breaker opening time to 0.3 s, notice that the system collapses. The ASM speed slows down to zero after 2 seconds.

Load Flow with a Swing Machine

In this section you make a load flow with two synchronous machine types: a *PV generator* and a *swing generator*. In your **power_machines** window, delete the inductive source and replace it with the Simplified Synchronous Machine block in p.u. from the Machines library. Rename this machine SSM 1000MVA. Add two constant blocks at the Pm and E inputs of the Simplified Synchronous Machine. These two blocks, which are used to specify the mechanical power and the machine internal voltage, will be automatically initialized when you perform a new load flow. Save this new system in your working directory as `power_machines2.mdl`. Open the SSM 1000 MVA dialog box and enter the following parameters:

Connection type	3-wire Y
Pn(VA), Vn(Vrms), fn(Hz)	[1000e6 25e3 60]
H(s), Kd(), p ()	[inf 0 2]
R(p.u.), X(p.u.)	[0.1 1.0]
Init. cond.	Leave all initial conditions at zero.

As you specify an infinite inertia, the speed and therefore the frequency of the machine are kept constant. Notice how easily you can specify an inductive short-circuit level of 1000 MVA and a quality factor of 10 with the per unit system.

Also, connect at inputs 1 and 2 of the SSM block two Constant blocks specifying respectively the required mechanical power (P_{mec}) and its internal voltage (E). These two constants are updated automatically according to the load flow solution.

When there is no voltage source imposing a reference angle for voltages, you must choose one of the synchronous machines as a reference. In a load flow program, this reference is called the *swing bus*. The swing bus absorbs or

generates the power needed to balance the active power generated by the other machines and the power dissipated in loads as well as losses in all elements.

Open the Powergui. In the **Tools** menu, select **Load Flow and Machine Initialization**. Change the SSM **Bus Type** to Swing Generator. Specify the load flow by entering the following parameters for the SM and ASM machines:

SM 1000 MVA:

Terminal voltage UAB 2400 Vrms
Active power 0 W

ASM 2250 HP:

Mechanical power 1.492e+06 W (2000 HP)

For the SSM swing machine you only have to specify the requested terminal voltage (magnitude and phase). The active power is unknown. However, you can specify an active power that is used as an initial guess and help load flow convergence. Respecify the following SSM parameters:

Terminal voltage 24984 Vrms
(this voltage obtained at bus B1 from the previous load flow)
Phase of UAN voltage 0 degrees
Active power guess 7.5e6 W
(estimated power = 6 MW (resistive load) + 1.5 MW motor load)

Click the **Update Load Flow** button. Once the load flow is solved the following solution is displayed. Use the scroll bar of the left window to look at the solution for each of the three machines.

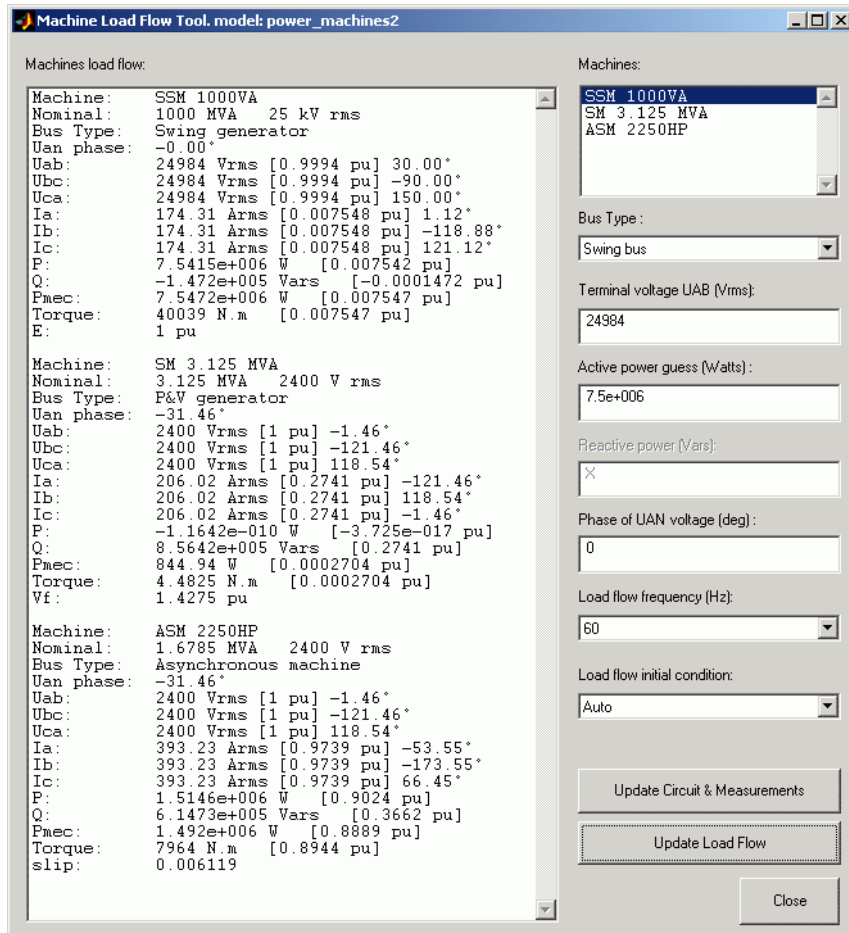

The active and reactive electrical powers, mechanical power, and internal voltage are displayed for the SSM block.

$P=7.542$ MW; $Q=-147$ kvar

$P_{mec}=7.547$ MW (or $7.547/1000=0.007547$ p.u.)

Internal voltage $E=1.0$ p.u.

The active and reactive electrical powers, mechanical power, and field voltage of the SM block are

$P=0$ W; $Q=856$ kvar
 $P_{mec}=844$ W
 $V_f=1.428$ p.u.

The active and reactive powers absorbed by the motor, slip, and torque of the ASM block are also displayed.

$P=1.515$ MW $Q=615$ kvar $P_{mec}=1.492$ MW (2000 HP)
Slip= 0.006119 Torque= 7964 N.m

As expected, the solution obtained is exactly the same as the one obtained with the R-L voltage source. The active power delivered by the swing bus is 7.54 MW (6.0 MW resistive load + 1.51 MW motor load = 7.51 MW, the difference (0.03 MW) corresponding to losses in the transformer).

Restart the simulation. You should get the same waveforms as those shown in the figure called Figure 2-8.

Reference

[1] Yeager, K.E., and J.R. Willis, "Modeling of Emergency Diesel Generators in an 800 Megawatt Nuclear Power Plant," *IEEE Transactions on Energy Conversion*, Vol. 8, No. 3, September, 1993.

Using the Phasor Solution Method for Stability Studies

Up to now, you have simulated a relatively simple power system consisting of a maximum of three machines. If you increase complexity of your network by adding extra lines, loads, transformers, and machines, the required simulation time becomes longer and longer. Moreover, if you are interested in slow electromechanical oscillation modes (typically between 0.02 Hz and 2 Hz on large systems) you might have to simulate for several tens of seconds, implying simulation times of minutes and even hours. The conventional continuous or discrete solution method is therefore not practical for stability studies involving low-frequency oscillation modes. To allow such studies, you have to use the phasor technique (see "Introducing the Phasor Simulation Method" on page 1-36).

For a stability study, we are not interested in the fast oscillation modes resulting from the interaction of linear R, L, C elements and distributed parameter lines. These oscillation modes, which are usually located above the fundamental frequency of 50 Hz or 60 Hz, do not interfere with the slow machine modes and regulator time constants. In the phasor solution method, these fast modes are ignored by replacing the network's differential equations by a set of algebraic equations. The state-space model of the network is therefore replaced by a transfer function evaluated at the fundamental frequency and relating inputs (current injected by machines into the network) and outputs (voltages at machine terminals). The phasor solution method uses a reduced state-space model consisting of slow states of machines, turbines, and regulators, thus dramatically reducing the required simulation time. Continuous variable-step solvers are very efficient in solving this type of problem. Recommended solvers are `ode23t` or `ode23tb` with a maximum time step of one cycle of the fundamental frequency (1/60 s or 1/50 s).

Now apply the phasor solution method to the two-machine system you have just simulated with the conventional method. Open the `power_machines` demo.

Double-click the Powergui. Select the **Phasor simulation** option. You must also specify the fundamental frequency used to solve the algebraic network equations. A default value of 60 Hz should already be entered in the **Frequency** menu. Close the Powergui and notice that **Phasors** appears on the Powergui icon, indicating that this new method can be used to simulate your circuit. To start the simulation in steady state, you must first repeat the load flow and machine initialization procedure explained in the previous section, "Load Flow and Machine Initialization" on page 2-27.

In the **Simulation Parameters** dialog box, specify a **Max step size** of 1/60 s (one cycle) and start the simulation.

Observe that simulation is now much faster. The results compare well with those obtained in the previous simulation. A comparison of synchronous machine and asynchronous machine signals is shown below.

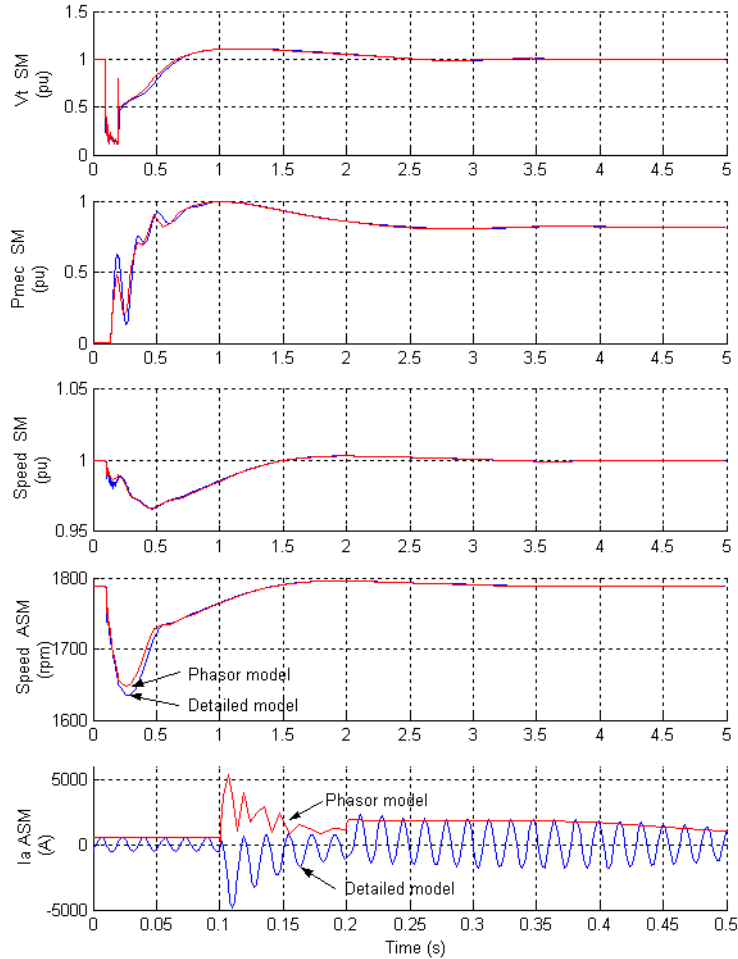

Comparison of Results for Continuous and Phasor Simulation Methods

The phasor solution method is illustrated on more complex networks presented in the Demos library. These demos are identified as

- Transient stability of two machines with power system stabilizers (PSS) and a static var compensator (SVC) (power_svc_pss model)
- Performance of three power system stabilizers for interarea oscillations (power_PSS model)

The first demo illustrates the impact of PSS and use of a SVC to stabilize a two-machine system. The second demo compares the performance of three different types of power system stabilizers on a four-machine, two-area system.

The phasor solution method is also used for FACTS models available in the factslib library. Three case studies demonstrating phasor simulation are presented in Chapter 6, “Transient Stability of Power Systems Using Phasor Simulation”.

Building and Customizing Nonlinear Models

SimPowerSystems provides a wide collection of nonlinear models. It can happen, however, that you need to interface your own nonlinear model with the standard models provided in the **powerlib** library. This model could be a simple nonlinear resistance simulating an arc or a varistor, a saturable inductor, a new type of motor, etc.

In the following section you learn how to build such a nonlinear model. A simple saturable inductance and a nonlinear resistance serve as examples.

Modeling a Nonlinear Inductance

Consider an inductor of 2 henries designed to operate at a nominal voltage, $V_{nom} = 120$ V RMS, and a nominal frequency, $f_{nom} = 60$ Hz. From zero to 120 V RMS the inductor has a constant inductance, $L = 2$ H. When voltage exceeds its nominal voltage, the inductor saturates and its inductance is reduced to $L_{sat} = 0.5$ H. The nonlinear flux-current characteristic is plotted in the next figure. Flux and current scales are in per units. The nominal voltage and nominal current are chosen as base values for the per-unit system.

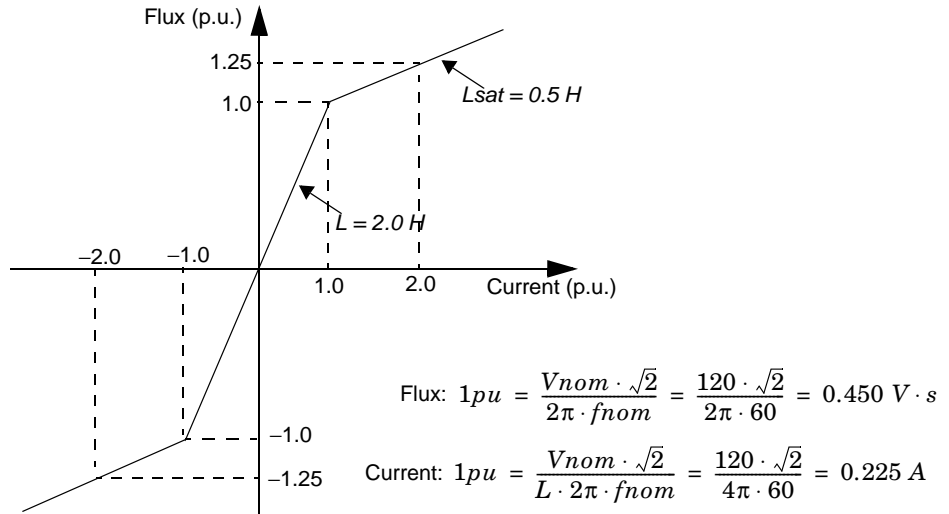

Figure 2-9: Flux-Current Characteristic of the Nonlinear Inductance

The current i flowing in the inductor is a nonlinear function of flux linkage ψ that, in turn, is a function of v appearing across its terminals. These relations are given by the following equations:

$$v = L \cdot \frac{di}{dt} = \frac{d\psi}{dt} \quad \text{or} \quad \psi = \int v \cdot dt$$

$$i = \frac{\psi}{L(\psi)}$$

The model of the nonlinear inductance can therefore be implemented as a controlled current source, where current i is a nonlinear function of voltage v , as shown.

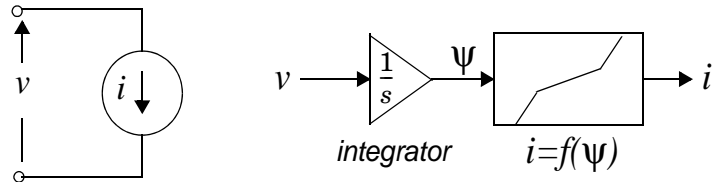

Model of a Nonlinear Inductance

Figure 2-10 shows a circuit using a 2 H nonlinear inductance. The nonlinear inductance is connected in series with two voltage sources (an AC Voltage Source block of 120 volts RMS, 60 Hz, and a DC Voltage Source block) and a 5 ohm resistor.

All the elements used to build the nonlinear model have been grouped in a subsystem named Nonlinear Inductance. The inductor terminals are labeled In and Out. Notice that a second output returning the flux has been added to the subsystem. You can use this Simulink output to observe the flux by connecting it to a Simulink Scope block.

The nonlinear model uses two **powerlib** blocks and two Simulink blocks. The two **powerlib** blocks are a Voltage Measurement block to read the voltage at the inductance terminals and a Controlled Current Source block. The direction of the arrow of the current source is oriented from input to output according to the model shown above.

The two Simulink blocks are an Integrator block computing the flux from the voltage input and a Look-Up Table block implementing the saturation characteristic $i = f(\psi)$ described by Figure 2-9.

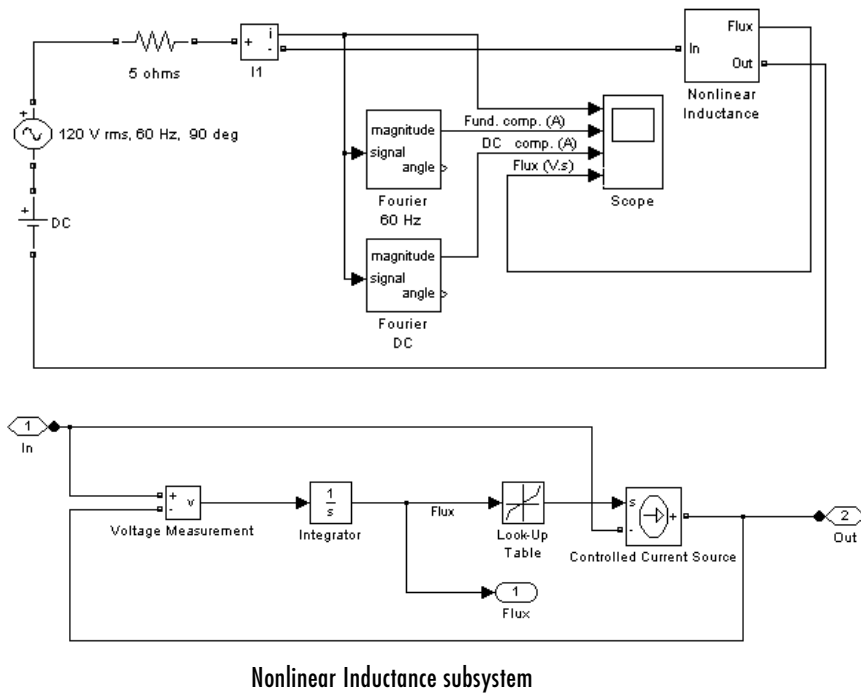

Figure 2-10: Implementation of a Nonlinear Inductance

Two Fourier blocks from the Measurements library of **powerlib_extras** are used to analyze the fundamental component and the DC component of the current.

Using blocks of the **powerlib** and Simulink libraries, build the circuit shown above. To implement the $i = f(\psi)$ relation, specify the following vectors in the Look-Up Table block:

Vector of input values (flux) $[-1.25 \ -1 \ 1 \ 1.25] \cdot (120 \cdot \sqrt{2}) / (2\pi \cdot 60)$

Vector of output values (current) $[-2 \ -1 \ 1 \ 2] \cdot (120 \cdot \sqrt{2}) / (4\pi \cdot 60)$

Save your circuit as circuit7.

Set the following parameters for the two sources:

AC source

Peak amplitude $120 \cdot \sqrt{2}$

Phase 90 degrees

Frequency 60 Hz

DC source

Amplitude 0 V

Adjust the simulation time to 1.5 s and select the ode33tb integration algorithm with default parameters. Start the simulation.

As expected, the current and the flux are sinusoidal. Their peak values correspond to the nominal values.

$$Peak \cdot Current = \frac{120 \cdot \sqrt{2}}{2 \cdot 2\pi \cdot 60} = 0.225 \text{ A}$$

$$Peak \cdot Flux = \frac{120 \cdot \sqrt{2}}{2\pi \cdot 60} = 0.450 \text{ V} \cdot \text{s}$$

Current and flux waveforms are shown.

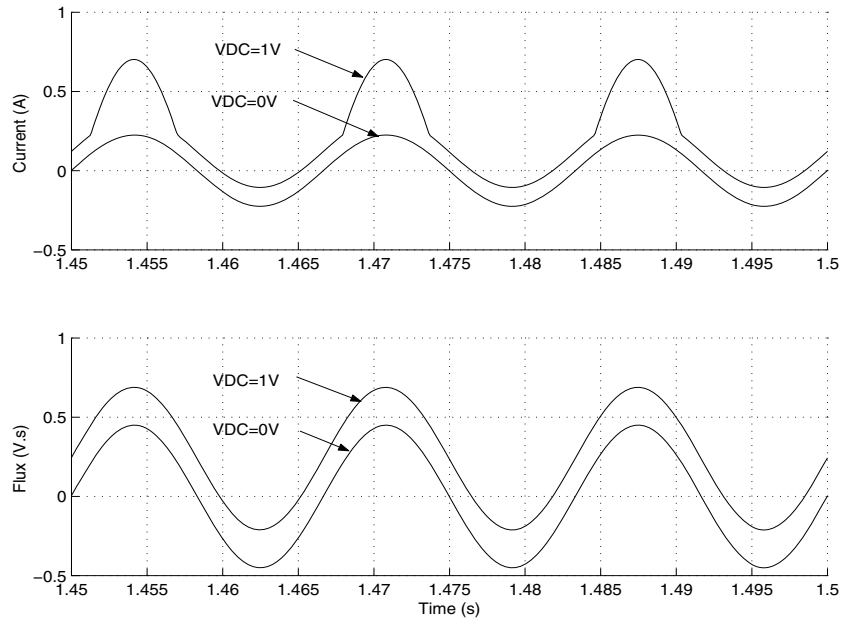

Figure 2-11: Current and Flux Waveforms Obtained with VDC = 0 V and VDC = 1 V

Now change the DC voltage to 1 V and restart the simulation. Observe that the current is distorted. The 1 V DC voltage is now integrated, causing a flux offset, which makes the flux enter into the nonlinear region of the flux-current characteristic ($\psi > 0.450$ V.s). As a result of this flux saturation, the current contains harmonics. Zoom in on the last three cycles of the simulation. The peak value of the current now reaches 0.70 A and the fundamental component has increased to 0.368 A. As expected, the DC component of the current is $1 \text{ V} / 0.5 \Omega = 0.2$. The current and flux waveforms obtained with and without saturation are superimposed in the figure above.

Customizing Your Nonlinear Model

Simulink provides the Masking facilities to create a dialog box for your models. You can create a mask that specifies the following prompts and variables:

Nominal voltage (Volts rms):	Vnom
Nominal frequency (Hz):	Fnom
Unsaturated inductance (H):	L
Saturation characteristic [i1(pu) phi1(pu); i2 phi2; ...]:	sat

The resulting mask for your nonlinear inductance block is shown in the next figure.

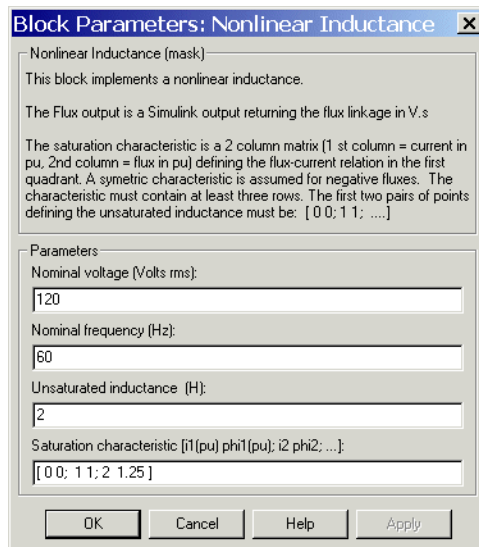

Dialog Box of the Nonlinear Inductance Block

The following code in the mask initializations of the block prepares the two vectors `Current_vect` and `Flux_vect` to be used in the Look-Up Table block of the model.

```
% Define base current and Flux for p.u. system
I_base = Vnom*sqrt(2)/(L*2*pi*fnom);
Phi_base = Vnom*sqrt(2)/(2*pi*fnom);

% Check first two points of the saturation characteristic
if ~all(all(sat(1:2,:)==[0 0; 1 1])),
    h=errordlg('The first two points of the characteristic must
be [0 0; 1 1]', 'Error');
    uiwait(h);
end

% Complete negative part of saturation characteristic
[npoints,ncol]=size(sat);
sat1=[sat ; -sat(2:npoints,:)];
sat1=sort(sat1);

% Current vector (A) and flux vector (V.s)
Current_vect=sat1(:,1)*I_base;
Flux_vect=sat1(:,2)*Phi_base;
```

As the saturation characteristic is specified only in the first quadrant, three lines of code are added to complete the negative part of the saturation characteristic. Notice also how the validity of the first segment of the saturation characteristic is verified. This segment must be defined by two points `[0 0; 1 1]` specifying a 1 p.u. inductance (nominal value) for the first segment.

Before you can use the masked block, you must apply the two internal variables defined in the initialization section of the block. Open the Look-Up Table block dialog box and enter the following variable names in the two fields:

Vector of input values (flux) `Flux_vect`

Vector of output values (current) `Current_vect`

Close the Nonlinear Inductance subsystem and start the simulation. You should get the same waveforms as shown in Figure 2-11.

Modeling a Nonlinear Resistance

The technique for modeling a nonlinear resistance is similar to the one used for the nonlinear inductance.

A good example is a metal-oxide varistor (MOV) having the following V-I characteristic:

$$i = I_o \cdot \left(\frac{v}{V_o}\right)^\alpha$$

where

v, i = Instantaneous voltage and current

V_o = Protection voltage

I_o = Reference current used to specify the protection voltage

α = Exponent defining the nonlinear characteristic (typically between 10 and 50)

The following figure shows an application of such a nonlinear resistance to simulate a MOV used to protect equipment on a 120 kV network. To keep the circuit simple, only one phase of the circuit is represented.

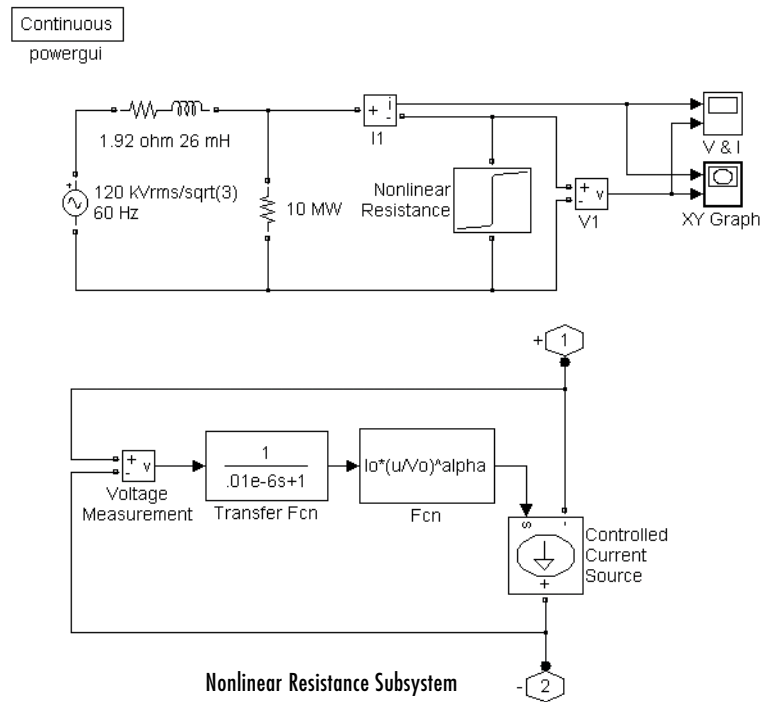

Nonlinear Resistance Applied on a 120 kV Network

Using blocks of the **powerlib** and Simulink libraries, build this circuit. Group all components used to model the nonlinear model in a subsystem named Nonlinear Resistance. Use an X-Y Graph block to plot the V-I characteristic of the Nonlinear Resistance subsystem.

The model does not use a Look-Up Table block as in the case of the nonlinear inductance model. As the analytical expression of current as a function of voltage is known, the nonlinear $I(V)$ characteristic is implemented directly with a Math Function block from the Math Operations library of Simulink.

This purely resistive model contains no states. It produces an algebraic loop in the state-space representation of the circuit, as shown in the next figure. See the SimPowerSystems Block Reference for more details on how SimPowerSystems works.

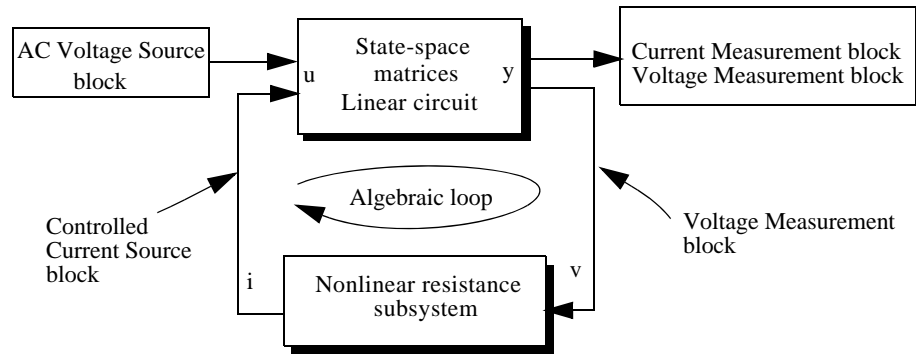

Algebraic Loop Introduced by the Nonlinear Resistance Model

Although Simulink can solve algebraic loops, they often lead to slow simulation times. You should break the loop with a block that does not change the nonlinear characteristic. Here a first-order transfer function $H(s) = 1/(1+Ts)$ is introduced into the system, using a fast time constant ($T = 0.01 \mu s$).

Use the technique explained for the nonlinear inductance block to mask and customize your nonlinear resistance block as shown.

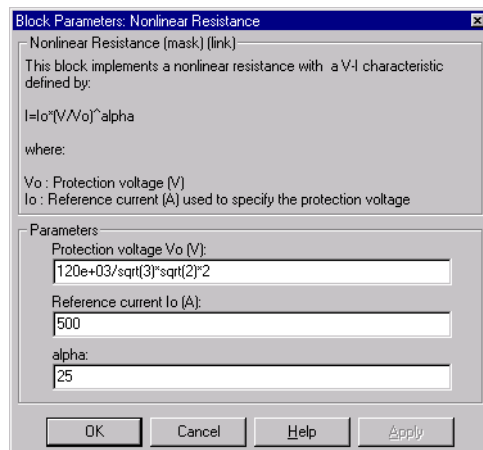

Dialog Box of the Nonlinear Resistance Block

Open the dialog box of your new masked block and enter the parameters shown in the figure above. Notice that the protection voltage V_0 is set at 2 p.u. of the nominal system voltage. Adjust the source voltage at 2.3 p.u. by entering the following peak amplitude:

$$120e3/\sqrt{3}*\sqrt{2}*2.3$$

Save your circuit as `circuit8`.

Using the `ode23t` integration algorithm, simulate your `circuit8` system for 0.1 s. The results are shown below.

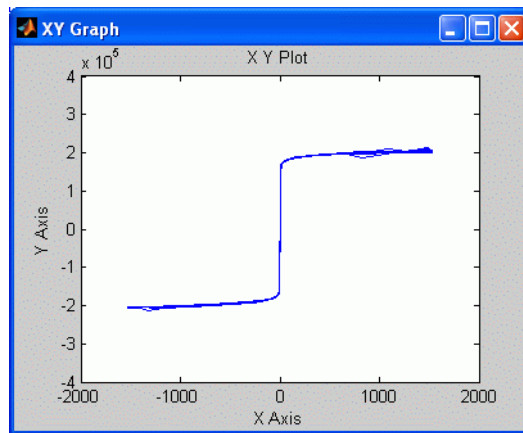
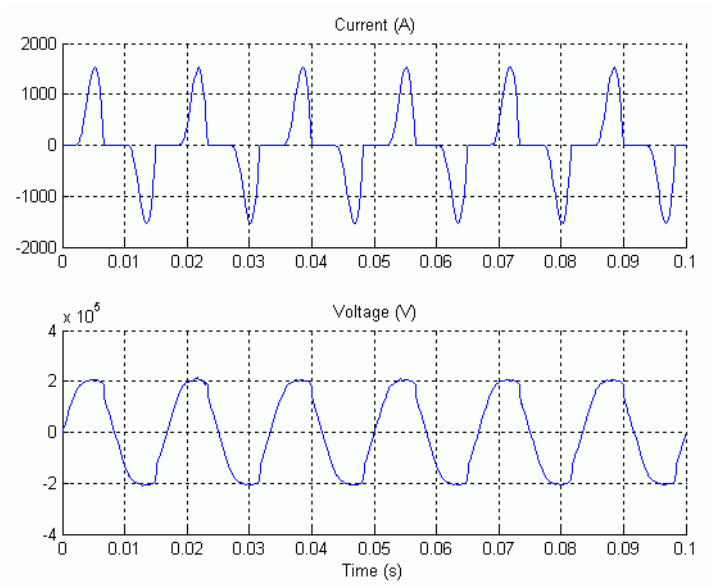

Current and Voltage Waveforms and V-I Characteristic Plotted by the X-Y Graph Block

Creating Your Own Library

Simulink lets you create your own libraries of SimPowerSystems blocks. To create a library, in the **File** menu choose **New Library**. A new Simulink window named **Library: untitled** opens. Now copy the Nonlinear Inductance block of your `circuit7` system and the Nonlinear Resistance block of your `circuit8` system into that library. Save this library as **my_powerlib**. Next time you develop a new model, you can add it to your personal library. You can also organize your library in different sublibraries according to their functions, as is done in the **powerlib** library.

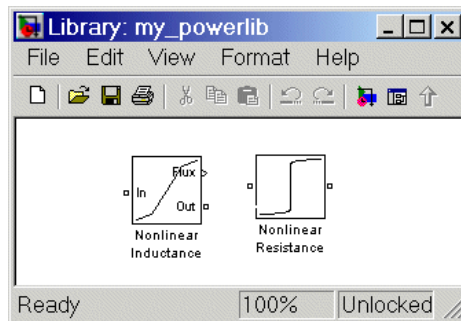

Nonlinear Inductance and Resistance Blocks in my_powerlib

One advantage of using a library is that all blocks that you copy from that library are referenced to the library. In other words, if you make a correction in your library block, the correction is automatically applied to all circuits using that block.

Connecting Your Model with Other Nonlinear Blocks

You now learn how to avoid error messages that can appear with nonlinear blocks when they are simulated by a current source. Obviously, a current source cannot be connected in series with an inductor, another current source, or an open circuit. Such circuit topologies are forbidden in SimPowerSystems.

Similarly, if your nonlinear model uses a Controlled Voltage Source block, this model could not be short-circuited or connected across a capacitor.

Suppose, for example, that you want to study the inrush current in a nonlinear inductance when it is energized on a voltage source. Using blocks from

powerlib library and **my_powerlibrary**, you can build the circuit shown here. Change the Breaker block parameters as follows:

Snubber resistance Rs	inf (no snubber)
Snubber capacitance Cs	0
External control	Not selected
Switching times	[1/60]

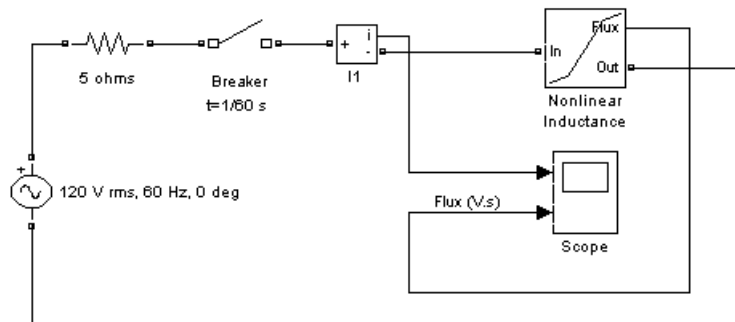

Circuit Topology Causing an Error

If you try to simulate this circuit, you get the following error message.

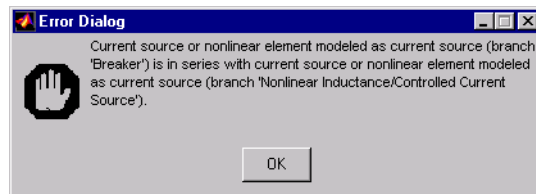

This topology is forbidden because two nonlinear elements simulated by current sources are connected in series: the Breaker block and the Nonlinear Inductance block. To be able to simulate this circuit, you must provide a current path around one of the two nonlinear blocks. You could, for example, connect a large resistance, say 1 M Ω , across the Breaker block or the Inductance block.

In this case, it is more convenient to choose the Breaker block because a series RC snubber circuit is provided with the model. Open the Breaker block dialog box and specify the following snubber parameters:

Snubber resistance R_s (ohms)	1e6
Snubber capacitance C_s (F)	inf

Notice that to get a purely resistive snubber you have to use an infinite capacitance.

Note Using an inductive source impedance (R-L series) instead of a purely resistive impedance would have produced another error message, because the current source modeling the nonlinear inductance would have been in series with an inductance, even with a resistive snubber connected across the breaker. In such a case, you could add either a parallel resistance across the source impedance or a large shunt resistance connected between one breaker terminal and the source neutral terminal.

Make sure that the phase angle of the voltage source is zero. Use the ode23t integration algorithm and simulate the circuit for 1 second. Voltage and current waveforms are shown here.

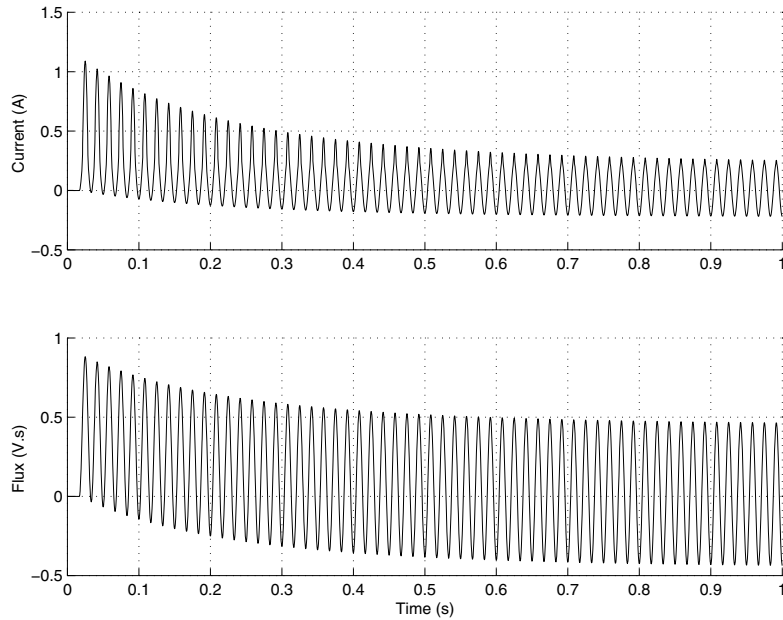

Current and Flux Waveforms When Energizing the Nonlinear Inductance with Maximum Flux Offset

The figure above shows that energizing the inductor at a zero crossing of voltage results in a maximum flux offset and saturation.

Building a Model Using Model Construction Commands

This section shows you how to use model construction commands to add blocks to your models and connect them.

Suppose you want to add a PI Section Line block and a Voltage Measurement block to your model, connect the + terminal of the voltage Measurement block to the left end of the PI Section Line block, and connect the - terminal of the Voltage Measurement block to the right end of the PI Section Line block.

The following code shows you how to add and position the two blocks in your model.

```
add_block('powerlib/Elements/Pi Section Line','Mymodel/Block1');
add_block('powerlib/Measurements/Voltage Measurement',
'Mymodel/Block2');
set_param('Mymodel/Block1','position',[340,84,420,106]);
set_param('Mymodel/Block2','position',[520,183,545,207]);
```

For each block you want to connect, you need to know the handles of the terminal ports.

```
Block1PortHandles = get_param('Mymodel/Block1','PortHandles');
Block2PortHandles = get_param('Mymodel/Block2','PortHandles');
```

The `add_line` command uses the `RConn` and `LConn` fields of the `Block1PortHandles` and `Block2PortHandles` structure variables to connect the blocks. The `RConn` field represents the right connectors of the blocks and the `LConn` field represents the left connectors. You then need to specify to the `add_line` command the indices of the connectors you want to connect.

```
add_line('Mymodel',Block1PortHandles.LConn(1),
Block2PortHandles.LConn(1));
add_line('Mymodel',Block1PortHandles.RConn(1),
Block2PortHandles.LConn(2));
```

Improving Simulation Performance

SimPowerSystems gives you many tools to speed up your power system simulations. Depending on your model, you can choose among continuous, discrete, and phasor integration methods. Simulink and related products provide additional ways to enhance model performance, including code generation, creating your own model libraries, and tuning block parameters.

How SimPowerSystems Works (p. 3-2)	Overview of what SimPowerSystems does when it analyzes and runs your models
Choosing an Integration Method (p. 3-5)	Advantages and disadvantages of continuous, discrete, and phasor simulation of power system models
Simulating with Continuous Integration Algorithms (p. 3-7)	How to integrate continuous time power models with SimPowerSystems
Simulating Discretized Electrical Systems (p. 3-11)	How to solve discretized power models with SimPowerSystems
Simulating Power Electronic Models (p. 3-13)	How to simulate power electronic models with SimPowerSystems
Increasing Simulation Speed (p. 3-14)	Ways to optimize simulation speed and efficiency, including the Simulink Accelerator and Real-Time Workshop®
The Nonlinear Model Library (p. 3-16)	Using and modifying the powerlib_models library to model nonlinear power components
Creating Your Own Library of Models (p. 3-18)	Creating your own custom power system blocks with the Simulink block masking feature
Changing Your Circuit Parameters (p. 3-19)	Modifying SimPowerSystems block parameters during simulation and automating with MATLAB scripts

How SimPowerSystems Works

Once you have built your circuit with the blocks of **powerlib**, you can start the simulation just like any other Simulink model. Each time you start the simulation, a special initialization mechanism is called. This initialization process computes the state-space model of your electric circuit and builds the equivalent system that can be simulated by Simulink.

The `power_analyze` command is part of that process. It obtains the state-space model and builds the Simulink model of your circuit. You can also call `power_analyze` from the command line to obtain the state-space model of the linear part of the circuit. When called by the initialization process, `power_analyze` performs the following five steps as shown in Figure 3-1:

- 1** Sorts all SimPowerSystems blocks, gets the block parameters and evaluates the network topology. The blocks are separated into linear and nonlinear blocks, and each electrical node is automatically given a node number.
- 2** Once the network topology has been obtained, the state-space model (A, B, C, D matrices) of the linear part of the circuit is computed by the `power_statespace` command. All steady-state calculations and initializations are performed at this stage.

If you have chosen to discretize your circuit, the discrete state-space model is computed from the continuous state-space model, using the Tustin method.

If you are using the phasor solution method, the state-space model is replaced with the complex transfer matrix $H(j\omega)$ relating inputs and outputs (voltage and current phasors) at the specified frequency. This matrix defines the network algebraic equations.

- 3** Builds the Simulink model of your circuit and stores it inside the Powergui block located at the top level of your model.

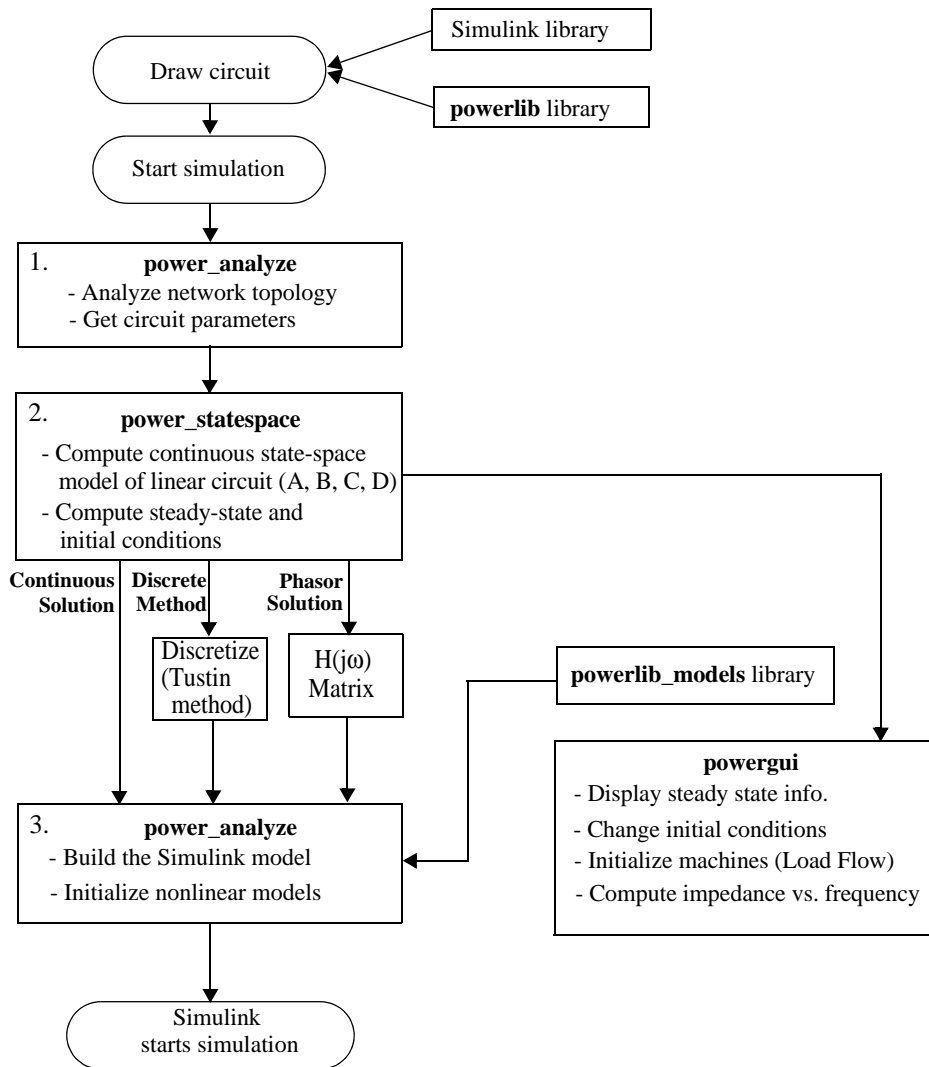

Figure 3-1: SimPowerSystems Flowchart

The Simulink model uses an S-Function block to model the linear part of the circuit. Predefined Simulink models are used to simulate nonlinear elements. These models can be found in the **powerlib_models** library available with

SimPowerSystems. Simulink Source blocks connected at the input of the State-Space block are used to simulate the electrical source blocks.

The next figure represents the interconnections between the different parts of the complete Simulink model. The nonlinear models are connected in feedback between voltage outputs and current inputs of the linear model.

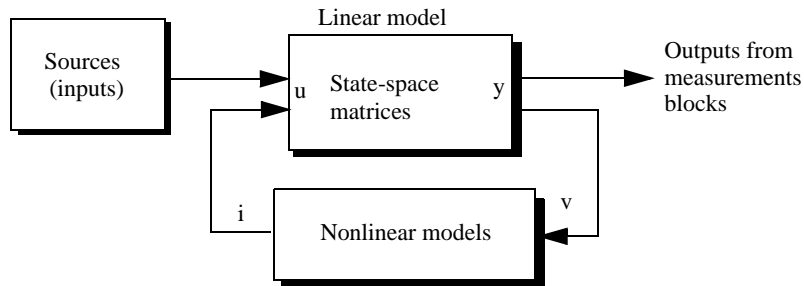

Figure 3-2: Interconnection of Linear Circuit and Nonlinear Models

Once `power_analyze` has completed the initialization process, Simulink starts the simulation. You can observe waveforms on scopes connected at the outputs of your measurement blocks. Through the Powergui, you can access the LTI viewer and obtain transfer functions of your system between any pair of input and output. The Powergui also allows you to perform a FFT analysis of recorded signals to obtain their frequency spectrum.

If you stop the simulation and drag a copy of the Powergui block into your circuit window, you have access to the steady-state values of inputs, outputs, and state variables displayed as phasors. You can also use the interface to modify the initial conditions. The Powergui block interface allows you to perform a load flow with circuits involving three-phase machinery and initialize the machine models so that the simulation starts in steady state. This feature avoids long transients due to mechanical time constants of machines. The Powergui block allows you to specify the desired frequency range, visualize impedance curves, and store results in your workspace for Impedance Measurement blocks connected in your circuit.

Choosing an Integration Method

Three solution methods are available through the Powergui block. These are:

- Continuous solution method using Simulink variable-step solvers
- Discretization for solution at fixed time steps
- Phasor solution method using Simulink variable-step solvers

Continuous Versus Discrete Solution

One important feature of SimPowerSystems is its ability to simulate electrical systems either with continuous variable-step integration algorithms or with a fixed-step using a discretized system. For small size systems, the continuous method is usually more accurate. Variable-step algorithms are also faster because the number of steps is fewer than with a fixed-step method giving comparable accuracy. When using line-commutated power electronics, the variable-step, event-sensitive algorithms detect the zero crossings of currents in diodes and thyristors with a high accuracy so that you do not observe any current chopping. However, for large systems (containing either a large number of states or nonlinear blocks), the drawback of the continuous method is that its extreme accuracy slows down the simulation. In such cases, it is advantageous to discretize your system. In the following two sections, we explain these two methods, their advantages, and their limitations.

What do we mean by “small size” and “large size”? Although the distinction is not sharp, you can consider small size a system that contains fewer than 30 electrical states and fewer than 6 electronic switches. Circuit breakers do not affect the speed much, because unlike power electronic switches, which are commutated at every cycle, these devices are operated only a couple of times during a test.

Phasor Solution Method

If you are interested only in the changes in magnitude and phase of all voltages and currents when switches are closed or opened, you don't need to solve all differential equations (state-space model) resulting from the interaction of R, L, C elements. You can instead solve a much simpler set of algebraic equations relating the voltage and current phasors. This is what the phasor solution method does. As its name implies, this method computes voltages and currents as phasors. The phasor solution method is particularly useful for studying

transient stability of networks containing large generators and motors. In this type of problem, we are interested in electromechanical oscillations resulting from interactions of machine inertias and regulators. These oscillations produce a modulation of the magnitude and phase of fundamental voltages and currents at low frequencies (typically between 0.02 Hz and 2 Hz). Long simulation times are therefore required (several tens of seconds). The continuous or discrete solution methods are not appropriate for this type of problem.

In the phasor solution method, the fast modes are ignored by replacing the network differential equations by a set of algebraic equations. The state-space model of the network is replaced by a complex matrix evaluated at the fundamental frequency and relating inputs (currents injected by machines into the network) and outputs (voltages at machine terminals). As the phasor solution method uses a reduced state-space model consisting of slow states of machines, turbines and regulators, it dramatically reduces the required simulation time.

Continuous variable-step solvers are very efficient in solving this type of problem. Recommended solvers are `ode23t` or `ode23tb` with a maximum time step of one cycle of the fundamental frequency (1/60 s or 1/50 s). You must keep in mind however that this faster solution technique gives the solution only in the vicinity of the fundamental frequency.

Simulating with Continuous Integration Algorithms

Simulink provides a variety of solvers. Most of the variable-step solvers work well with linear circuits. However circuits containing nonlinear models, especially circuits with circuit breakers and power electronics, require stiff solvers.

Choosing an Integration Algorithm

Best accuracy and fastest simulation speed is usually achieved with ode23t.

Solver	ode23t
Relative tolerance	1e-3
Absolute tolerance	auto
Maximum step size	auto
Initial step size	auto

Normally, you can choose auto for the absolute tolerance and the maximum step size. In some occasions you might have to limit the maximum step size and the absolute tolerance. Selecting too small a tolerance can slow down the simulation considerably. The choice of the absolute tolerance depends on the maximum expected magnitudes of the state variables (inductor currents and capacitor voltages). For example, if you work with high-power converters where expected voltage and currents are thousands of volts and amperes, an absolute tolerance of 0.1 or even 1.0 should be sufficient. If you are working with low-power circuits involving maximum values of 100 V and 10 A, you may use a smaller absolute tolerance, such as 0.001 or 0.01.

Simulating Switches and Power Electronic Devices

Two methods are used for simulation of switches and power electronic devices:

- If the switch is purely resistive the switch model is considered as part of the linear circuit. The state-space model of the circuit, including open and closed switches, is therefore recalculated at each switch opening or closing, producing a change in the circuit topology. This method is always used with the Breaker block and the Ideal Switch block because these elements do not have internal inductance. It is also applied for the power electronic blocks

when $R_{on} > 0$ and $L_{on} = 0$, and for the Universal Bridge with forced commutated devices.

- If the switch contains a series inductance (Diode and Thyristor with $L_{on} > 0$, IGBT, MOSFET, or GTO), the switch is simulated as a current source driven by voltage across its terminals. The nonlinear element (with a voltage input and a current output) is then connected in feedback on the linear circuit, as shown in the Figure 3-2.

Note You have therefore the choice to simulate diodes and thyristors with or without L_{on} internal inductance. In most applications, it is not necessary to specify an inductance L_{on} . However, for circuit topologies resulting in zero commutation or overlap angle, you have to specify a switch inductance L_{on} to help commutation.

Consider for example the circuit shown in the following figure. This circuit is available in the `power_rectifier_ideal` model. The thyristor bridge is fed from an infinite source (zero impedance) so that the commutation between thyristors is quasi instantaneous.

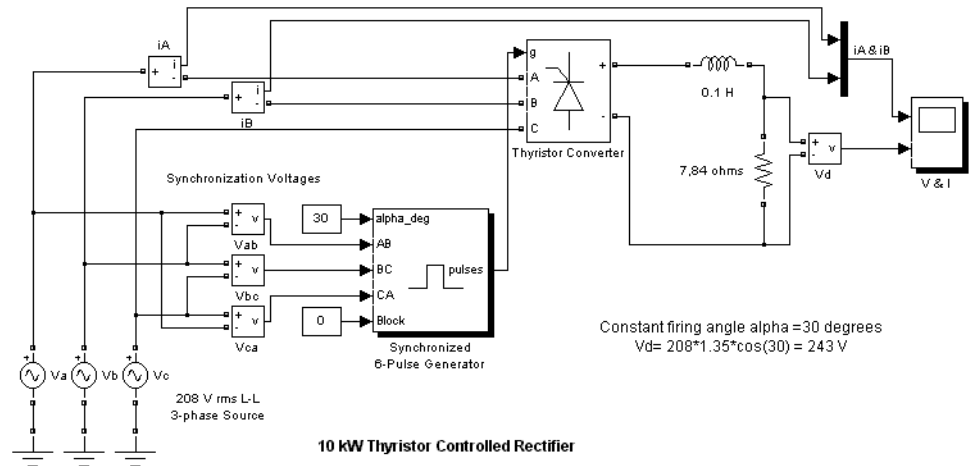

Three-Phase Thyristor Rectifier on Infinite Source

If you simulate this circuit without internal thyristor inductances ($L_{on} = 0$), observe high current spikes flowing in the three lines. This happens because during commutation two thyristors connected to the same positive or negative terminal of the bridge are in conduction for a short period of time, applying a line-to-line short circuit on the source (see the Figure 3-3). During commutation, the current is limited only by the internal resistance of thyristors (with $R_{on} = 0.01$ ohms, the current reaches 7.35 kA ($208 * \sqrt{2} * \sin(30^\circ) / (2 * 0.01)$) or 245 times the normal DC current of 30 A). These short circuits can be avoided by using a small $L_{on} = 1 \mu\text{H}$ in the thyristor model. If you repeat the simulation, you get square current waveforms with a peak value of 30 A.

If you zoom in on the line current during a commutation, you discover that the commutation is not instantaneous. The commutation time depends on the L_{on} value and the DC current.

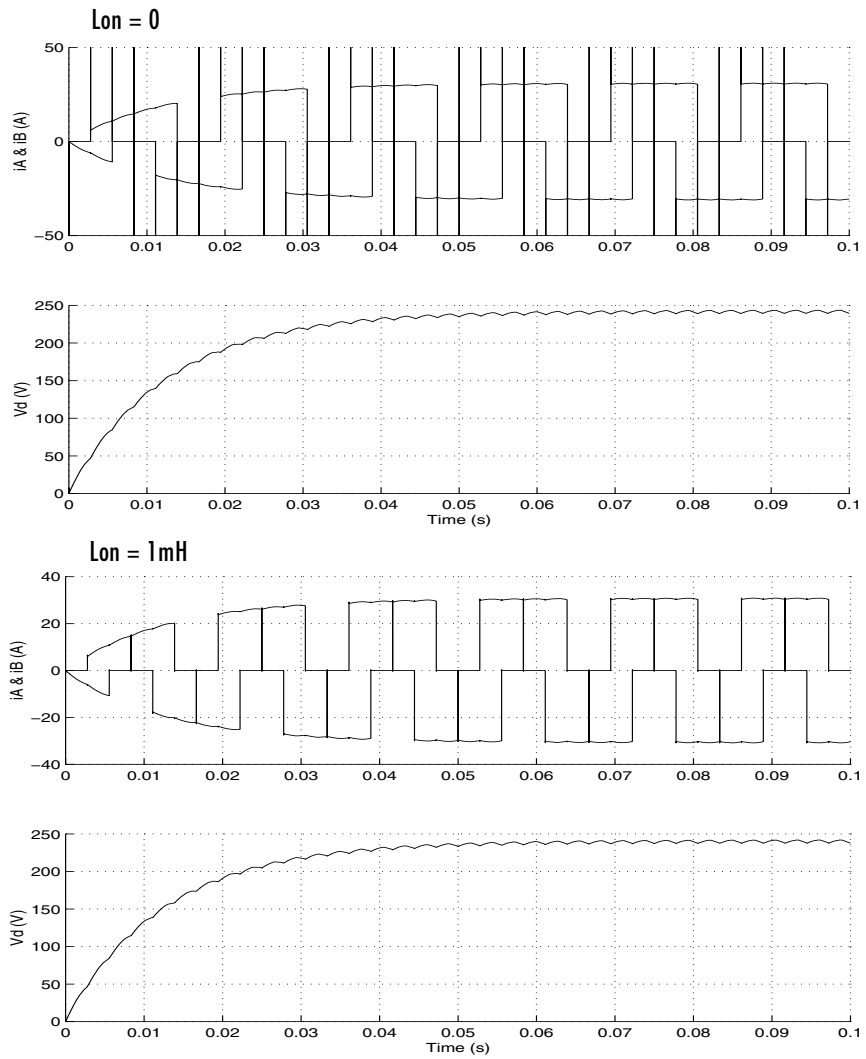

Figure 3-3: Source Currents and DC Load Voltage with $L_{on} = 0$ and $L_{on} = 1 \mu\text{H}$

Simulating Discretized Electrical Systems

You implement discretization by selecting **Discretize electrical model** in the Powergui block dialog box. The sample time is specified in the block dialog box. The electrical system is discretized using the Tustin method, which is equivalent to a fixed-step trapezoidal integration. To avoid algebraic loops, the electrical machines are discretized using the Forward Euler method.

The precision of the simulation is controlled by the time step you choose for the discretization. If you use too large a sample time, the precision might not be sufficient. The only way to know if it is acceptable is to repeat the simulation with different sample times or to compare with a continuous method and to find a compromise for the largest acceptable sample time. Usually sample times of 20 μs to 50 μs give good results for simulation of switching transients on 50 Hz or 60 Hz power systems or on systems using line-commutated power electronic devices such as diodes and thyristors. However, for systems using forced-commutated power electronic switches, you must reduce the time step. These devices, the insulated-gate-bipolar transistor (IGBT), the field-effect transistor (FET), and the gate-turnoff thyristor (GTO) are usually operating at high switching frequencies. For example, simulating a pulse-width-modulated (PWM) inverter operating at 8 kHz requires a maximum time step of 1 μs or less.

Note that even if you discretize your electric circuit, you can still use a continuous control system. However, the simulation speed is improved by use of a discrete control system.

Limitations of Discretization with Nonlinear Models

There are a few limitations to discretizing nonlinear models.

Minimal Load Is Required at Machine Terminals

When using electrical machines in discrete systems, you might have to use a small parasitic resistive load, connected at the machine terminals, to avoid numerical oscillations. Large sample times require larger loads. The minimum resistive load is proportional to the sample time. As a rule of thumb, remember that with a 25 μs time step on a 60 Hz system, the minimum load is approximately 2.5% of the machine nominal power. For example, a 200 MVA synchronous machine in a power system discretized with a 50 μs sample time

requires approximately 5% of resistive load or 10 MW. If the sample time is reduced to 20 μs , a resistive load of 4 MW should be sufficient.

Lon = 0 Is Used for Power Electronic Devices

Naturally commutated devices (diodes and thyristors), as well as forced-commutated devices (IGTO, IGBT, FET), used in a discretized circuit must have a zero internal inductance. If you discretize a circuit containing power electronic devices with $L_{on} > 0$, SimPowerSystems prompts you with a warning indicating that L_{on} will be reset to zero.

Simulating Power Electronic Models

There are two types of circuits using power electronics.

Circuit Using Forced-Commutated Power Electronics

In this type of circuit, the semiconductor such as IGBT GTO FET turns off instantaneously when the gate signal is removed. This switching off may in turn cause instantaneous switching on of another device (usually a diode).

This problem of instantaneous switching of two or more devices in the same time step has been solved in SimPowerSystems, both for continuous and discrete fixed time step solvers. It is now possible to discretize circuits with any type of topology, like multilevel converters. This was possible before only with the use of the Universal Bridge.

The power electronic models are implemented directly in the S-functions that compute the state-space equations of the model.

Circuit Using Naturally Commutated Power Electronics

In this type of circuit, the diode or thyristor is turned off at zero crossing of current. It means that if the model is discretized at fixed time step, the natural zero crossing will most probably occur between two time steps. As current inversion is detected at a time step following the real zero crossing, a small negative current will be chopped. This current chopping in inductive circuits will cause numerical oscillations that can be observed in simple rectifier circuits.

This problem is not yet solved in SimPowerSystems because we still use a fixed-step solver. (The system is discretized using a trapezoidal solver.) The way to avoid this problem is to increase the RC snubbers connected across diodes or thyristors. But if large time steps are used, this may lead to unacceptable leakage current in the snubbers.

Fortunately, the trend of power electronics is to use forced-commutated power electronics and PWM rather than naturally commutated power electronics.

Increasing Simulation Speed

Once the proper method (continuous, discrete, or phasor), solver type, and parameters have been selected, there are additional steps you can take to optimize your simulation speed:

- Discretizing your electric circuit and your control system. You can even use a larger sample time for the control system, provided that it is a multiple of the smallest sample time.
- Simulating large systems or complex power electronic converters can be time consuming. If you have to repeat several simulations from a particular operating point, you can save time by specifying a vector of initial states in the **Simulation** → **Simulation parameters** → **Workspace IO** dialog box pane. This vector of initial conditions must have been saved from a previous simulation run.
- Reducing the number of open scopes and the number of points saved in the scope also helps in reducing the simulation time.
- Installing the Simulink Accelerator. The performance gain obtained with the Accelerator varies with the size and complexity of your model. Typically you can expect performance improvements by factors of two to 10.

Using Accelerator Mode and Real-Time Workshop

The Simulink Accelerator mode is explained in the Simulink user's guide.

The Simulink Accelerator speeds up the execution of Simulink models by replacing the interpreted M code running beneath the Simulink blocks with compiled code as your model executes. The Simulink Accelerator uses portions of Real-Time Workshop (RTW) to generate this code on the fly. Although the Simulink Accelerator uses RTW technology, Real-Time Workshop is not required to run it. Also, if you do not have your own C compiler installed, you can use the lcc C compiler provided with MATLAB.

To activate the Simulink Accelerator, select **Accelerator** instead of **Normal** in the **Simulation** menu of your model window. Alternatively, select **Accelerator** in the pull-down menu to the right and below the **Simulation** menu.

The following table shows typical performance gains obtained with discretization and Simulink Accelerator applied on the following two demos: a DC drive using a chopper and the AC-DC converter using a three-phase,

three-level voltage-sourced converter. Two versions of the DC drive model are provided in the Demos library: a continuous version, `power_dcdrive`, and a discrete version, `power_dcdrive_disc`. The AC-DC converter is available as the `power_3levelVSC` demo.

Simulation Method	Simulation Time in Seconds*	
	DC drive (Stop time = 2 s)	AC-DC converter (Stop time = 0.2 s)
Continuous: ode23t default parameters	12	—
Discrete	9.0 (Ts = 10 μ s)	14.5 (Ts = 5 μ s)
Discrete + Accelerator	5.2 (Ts = 10 μ s)	3.3 (Ts = 5 μ s)

* Simulation times obtained on a Pentium IV 2.6 GHz processor, with 512 MB of RAM

The table shows how discretizing your circuit speeds up the simulation by a factor of 1.33 for the DC drive. Using the Accelerator mode, an additional factor of 1.7 performance gain is obtained. For the AC-DC converter the Accelerator provides a gain of 4.4 times. For complex power electronic converter models, the Accelerator provides performance gains up to factors of 15.

To take full advantage of the performance enhancements made possible by converting your models to code, you must use Real-Time Workshop to generate stand-alone C code. You can then compile and run this code and, with xPC Target, also run it on a target PC operating the xPC Target real-time kernel.

The Nonlinear Model Library

The building blocks used to assemble the Simulink model of the nonlinear circuit are stored in a library named **powerlib_models**. You do not normally need to work with the **powerlib_models** library. You can access that library by entering `powerlib_models` in the MATLAB Command Window.

The Continuous Library

The Continuous library contains blocks that use voltage inputs (output of the state-space model of the linear circuit) and their current output is fed into the state-space model. For complex models, such as electrical machines requiring several inputs and outputs, vectorized signals are used. Useful internal signals are also returned by most of the models in a measurement output vector `m`.

For example, the Asynchronous Machine model is stored in two blocks named `asynchronous_machine` (electrical model) and `ASM_mechanics` (mechanical model). The electrical model uses as inputs a vector of four voltages, two rotor voltages and two stator voltages, respectively: (`VabR`, `VbcR`, `VabS`, `VbcS`). It returns a vector of four currents, two rotor currents and two stator currents, respectively: (`IaR`, `IbR`, `IaS`, `IbS`). The model also returns a measurement output vector of 20 signals. When the Asynchronous Machine block is used from the **powerlib** library, this measurement output vector is accessible through the `m` output of the machine icon. You can get details on the model inputs and outputs from the documentation of **powerlib** and **powerlib_models** block icons.

The Discrete Library

The Discrete library contains the discrete versions of the continuous models described above.

The Phasors Library

The Phasors library contains the phasor versions of some of the continuous models described above. See Chapter 1, “Getting Started” for more details on the phasor simulation.

The Switch Current Source Library

The Switch Current Source library contains models of power electronic devices with an internal inductance $L_{on} > 0$. All these continuous models are simulated by a current source external to the linear circuit. These devices are the diode, thyristor, gate-turnoff thyristor (GTO), metal-oxide-semiconductor field-effect transistor (MOSFET), and the insulated-gate-bipolar transistor (IGBT). As for electrical machines, these models use a voltage input (output of the state-space model of the linear circuit) and their current output is fed into the state-space model. All these models are vectorized.

Limitations of the Nonlinear Models

Because nonlinear models are simulated as current sources, they cannot be connected in series with inductors and their terminals cannot be left open.

If you feed a machine through an inductive source, `power_analyze` prompts you with an error message. You can avoid this by connecting large resistances in parallel with the source inductances or across the machine terminals.

A series RC snubber circuit is included in the model of the Breaker block and power electronics blocks. You should not have any problems if you keep these snubber circuits in service. The snubber can be changed to a single resistance by setting `Cs` to `Inf`, or to a single capacitor by setting `Rs = 0`. To eliminate the snubber, specify `Rs = Inf` or `Cs = 0`.

Modifying the Nonlinear Models of the `powerlib_models` Library

We do not recommend to modify the `powerlib_models` library. However you can use the models as a starting point to create your own version of the models. Use the technique described in “Building and Customizing Nonlinear Models” on page 2-38.

Creating Your Own Library of Models

SimPowerSystems provides a variety of basic building blocks to build more complex electric blocks. Using the masking feature of Simulink, you can assemble several elementary blocks from the **powerlib** library into a subsystem, build your own parameter dialog box, create the desired block icon, and place this new block in your personal library.

Chapter 1, “Getting Started” explains how to build a nonlinear model using a Voltage Measurement block and a Controlled Current Source block. The proposed examples (a nonlinear inductance and a nonlinear resistance) were relatively simple. Using the same principle, you can develop much more complex models using several controlled current sources, or even controlled voltage sources. Refer to the tutorial “Building and Customizing Nonlinear Models” on page 2-38.

Changing Your Circuit Parameters

Each time that you change a parameter of the **powerlib** library blocks, you have to restart the simulation to evaluate the state-space model and update the parameters of the nonlinear models. However, you can change any source parameter (Magnitude, Frequency, or Phase) during the simulation. The modification takes place as soon as you apply the modification or close the source block menu.

As for the Simulink blocks, all the **powerlib** library block parameters that you specify in the dialog box can contain MATLAB expressions using symbolic variable names. Before running the simulation, you must assign a value to each of these variables in your MATLAB workspace. This allows you to perform parametric studies by changing the parameter values in a MATLAB script.

Example of MATLAB Script Performing a Parametric Study

Suppose that you want to perform a parametric study in a circuit named `my_circuit` to find the impact of varying an inductance on switching transients. You want to find the highest overvoltage and the inductance value for which it occurred.

The inductance value of one of the blocks contains variable `L1`, which should be defined in your workspace. `L1` is varied in 10 steps from 10 mH to 100 mH and the values to be tested are saved in a vector, `L1_vec`. The voltage waveform to be analyzed is stored in a `ToWorkspace` block in array format with `V1` variable name.

You can write a MATLAB M-file that loops on the 10 inductance values and displays the worst case.

```
L1_vec= (10:10:100)*1e-3; % 10 inductances values 10/100 mH
V1_max=0;
for i=1:10
    L1=L1_vec(i);
    fprintf('Test No %d L1= %g H\n', i, L1);
    sim('my_circuit'); % performs simulation
    % memorize worst case
    if max(abs(V1))>V1_max,
        imax=i;
        V1_max=max(abs(V1));
    end
end
```

```
        end
    end

    fprintf('Maximum overvoltage= %g V occurred for L1=%g H\n', V1_max,
        L1_vec(imax));
```

Systems with Electric Drives

This chapter introduces the Electric Drives library of SimPowerSystems. This specialized library is designed for engineers from many disciplines who want to easily and accurately incorporate electric drives in the simulation of their systems.

About the Electric Drives Library (p. 4-2)	Presentation of the Electric Drives library: its contents and the advantages for the user.
Getting Started with Electric Drives Library (p. 4-4)	Information on electric drive fundamentals, including the general layout and features of the library's graphical user interface (GUI).
Simulating a DC Motor Drive (p. 4-13)	Step by step example showing how to simulate a DC drive model.
Simulating an AC Motor Drive (p. 4-38)	Step by step example showing how to simulate an AC drive model.
Mechanical Models (p. 4-68)	Descriptions of the Mechanical Shaft block and the Speed Reducer block.
Mechanical Coupling of Two Motor Drives (p. 4-71)	Study of the mechanical coupling of the AC4 (DTC three-phase induction motor-based drive) and DC2 (single-phase dual-converter DC motor drive) blocks.
Winding Machine (p. 4-77)	Study of a winding machine driven by the DC3 (two-quadrant three-phase rectifier DC motor drive) block.
Robot Axis Control Using Brushless DC Motor Drive (p. 4-84)	Study of a six degrees-of-freedom robot driven by the AC6 (brushless DC motor drive) blocks.
Building Your Own Drive (p. 4-95)	Study of how to build your own motor drive model according to your specific requirements.

About the Electric Drives Library

The Electric Drives library is designed for engineers from many disciplines who want to incorporate easily and accurately electric drives in the simulation of their systems. A specialized interface presents the parameters of the selected drive in a system-look topology, thereby simplifying the adjustments users may want to bring to the default values. Then they can seamlessly use any other toolboxes or blocksets to analyze the time or frequency behavior of the electric drive interacting with its system. The library is most helpful when a powerful drive has to be carefully maneuvered without ignoring the operating limits of the load on one side and of the power source on the other side. A good example is the electric drive system of a hybrid car that can switch in milliseconds from driving the wheels to recharging the batteries when the brakes are engaged.

Engineers and scientists can work readily with the library. The library has seven typical direct current (DC) drives used in industries and transportation systems, six alternating current (AC) drives providing more efficient and versatile motors from traction to positioning devices, and shaft and speed reducer models useful for connecting to the motor a model of load made of Simulink blocks. An added value of the library is parameters that assure the validity of the motor, the power converters, and the control system. When designing the library, particular attention was devoted to the motor models by comparing the models' behavior to the published data of the major manufacturers. Numerous examples, demos or case studies of typical drives are supplied with the library. Hopefully, typical user systems are similar to these analyzed systems, thereby saving time in building the practical system and supplying a known reference point in the analysis.

To access the Electric Drives library, open the SimPowerSystems main library, **powerlib**, then double-click the **Applications Libraries** icon. A new window opens containing the icons for the Electric Drives library, FACTS library, and DR library, as shown in the following illustration.

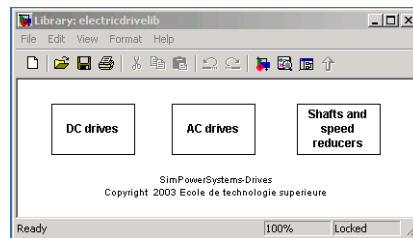
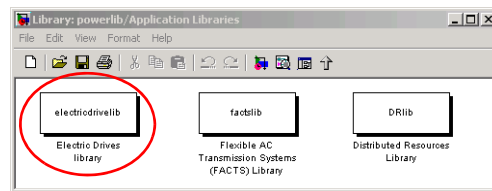
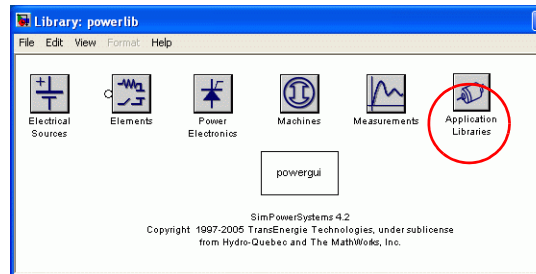

Accessing the Electric Drives Library

Getting Started with Electric Drives Library

To master the Electric Drives library, you must have some knowledge of electric drive fundamentals and know how to run simulations in the Simulink environment. This section introduces you to DC and AC drive fundamentals by discussing the following topics:

- “What Is an Electric Drive?” on page 4-4
- “Three Main Components of an Electric Drive” on page 4-5
- “Multiquadrant Operation” on page 4-7
- “Average-Value Models” on page 4-8
- “User Interface” on page 4-10
- “General Layout of the Library’s GUIs” on page 4-10
- “Features of the New GUIs” on page 4-11
- “Advanced Usage” on page 4-12

What Is an Electric Drive?

An electric drive is a system that performs the conversion of electric energy into mechanical energy at adjustable speeds. This is the reason why an electric drive is also called adjustable speed drive (ASD). Moreover, the electric drive, as we will see later, always contains a current (or torque) regulation in order to provide safe current control for the motor. Therefore, the electric drive torque/speed is able to match in steady state the torque/speed characteristics of any mechanical load. This motor to mechanical load match means better energy efficiency and leads to lower energy costs. In addition, during the transient period of acceleration and deceleration, the electric drive provides fast dynamics and allows soft starts and stops, for instance.

A growing number of applications require that the torque and speed must vary to match the mechanical load. Electric transportation means, elevators, computer disk drives, machine tools, and robots are examples of high-performance applications where the desired motion versus time profile must be tracked very precisely. Pumps, fans, conveyers, and HVAC (heat, ventilation, air conditioners) are examples of moderate performance applications where variable-speed operation means energy savings.

Three Main Components of an Electric Drive

An electric drive has three main components:

- The electric motor
- The power electronic converter
- The drive controller

The following figure shows the basic topology of an electric drive. Beside the three main components, the figure shows an electric power source, a mechanical load, electric and motion sensors, and a user interface.

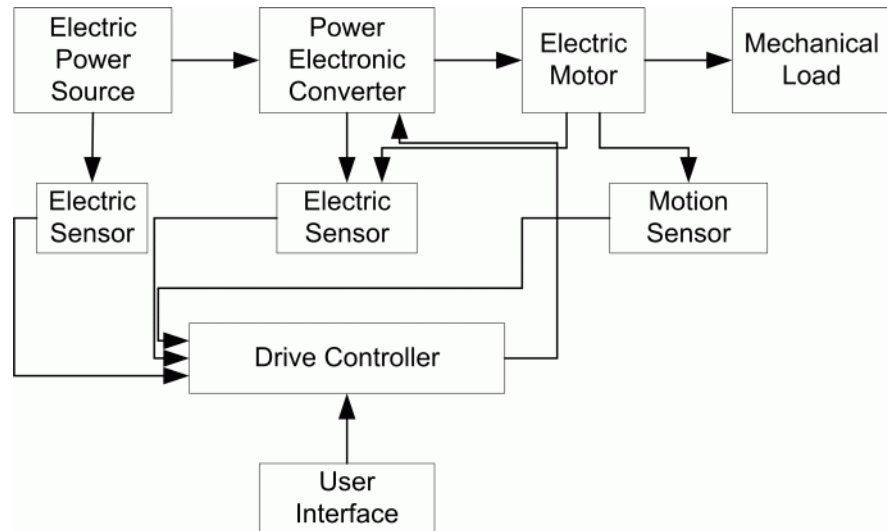

Electric Drive Basic Topology

The motor used in an electric drive is either a direct current (DC) motor or an alternating current (AC) motor. The type of motor used defines the electric drive's classification into DC motor drives and AC motor drives. The ease of producing a variable DC voltage source for a wide range of speed control made the DC motor drive the favorite electric drive up to the 1960s. Then the advances of power electronics combined with the remarkable evolution of microprocessor-based controls paved the way to the AC motor drive's expansion. In the 1990s, the AC motor drives took over the high-performance variable-speed applications.

The power electronic converter produces variable AC voltage and frequency from the electric power source. There are many types of converters depending on the type of electric drive. The DC motor drives are based on phase-controlled rectifiers (AC-DC converters) or on choppers (DC-DC converters), while the AC motor drives use inverters (DC-AC converters) or cyclo converters (AC-AC converters). The basic component of all the power electronic converters is the electronic switch, which is either semicontrolled (controllable on-state), as in the case of the thyristor, or fully controllable (controllable on-state and off-state), as in the cases of the IGBT (insulated gate bipolar transistor) and the GTO (gate turn off thyristor) blocks. The controllable feature of the electronic switch is what allows the converter to produce the variable AC voltage and frequency.

The purpose of the drive controller is essentially to convert the desired drive torque/speed profile into triggering pulses for the electronic power converter, taking into account various drive variables (currents, speed, etc.) fed back by the sensors. To accomplish this, the controller is based first on a current (or torque) regulator. The current regulator is mandatory because, as mentioned previously, it protects the motor by precisely controlling the motor currents. The set point (SP) of this regulator can be supplied externally if the drive is in torque regulation mode, or internally by a speed regulator if the drive is in speed regulation mode. In the SimPowerSystems Electric Drives library, the speed regulator is in series with the current regulator and is based on a PI controller that has three important features. First, the SP rate of change is limited so that the desired speed ramps gradually to the SP, in order to avoid sudden step changes. Second, the speed regulator output that is the SP for the current regulator is limited by maximum and minimum ceilings. Finally, the integral term is also limited in order to avoid wind-up. The following figure shows a block diagram of a PI controller-based speed controller.

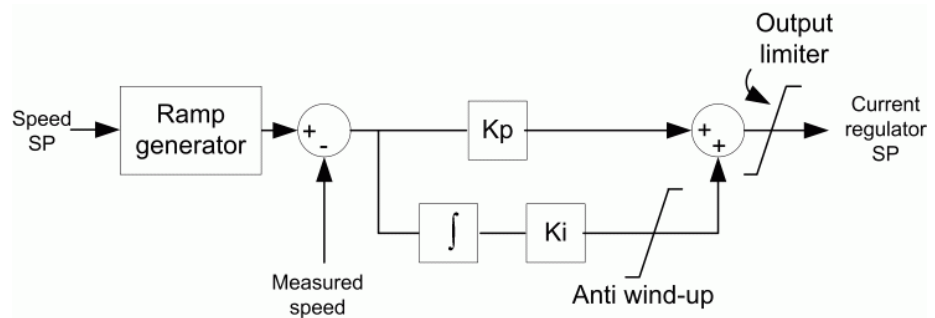

Block Diagram of the PI Controller-Based Speed Regulator

Multiquadrant Operation

For each electric drive application, the mechanical load to be driven has a specific set of requirements. The torque/speed possibilities of the electric drive can be represented as a speed versus torque graph consisting of four quadrants. In the first quadrant, the electric torque and the speed signs are both positive, indicating forward motoring since the electric torque is in the direction of motion. In the second quadrant, the electric torque sign is negative and the speed sign is positive, indicating forward braking since the electric torque is opposite to the direction of motion. In the third quadrant, the electric torque and speed signs are both negative, indicating reverse motoring. In the fourth quadrant, the electric torque sign is positive and the speed is negative, indicating reverse braking. The drive braking is handled either by a braking chopper (dynamic braking) or by bidirectional power flow (regenerative braking).

The following figure illustrates the four-quadrants operating region of an electric drive. Each quadrant has a constant torque region from 0 to \pm nominal speed ω_b and a region where the torque decreases inversely with the speed from ω_b to the maximum speed ω_{max} . This second region is a constant power region and is obtained by decreasing the motor magnetic flux.

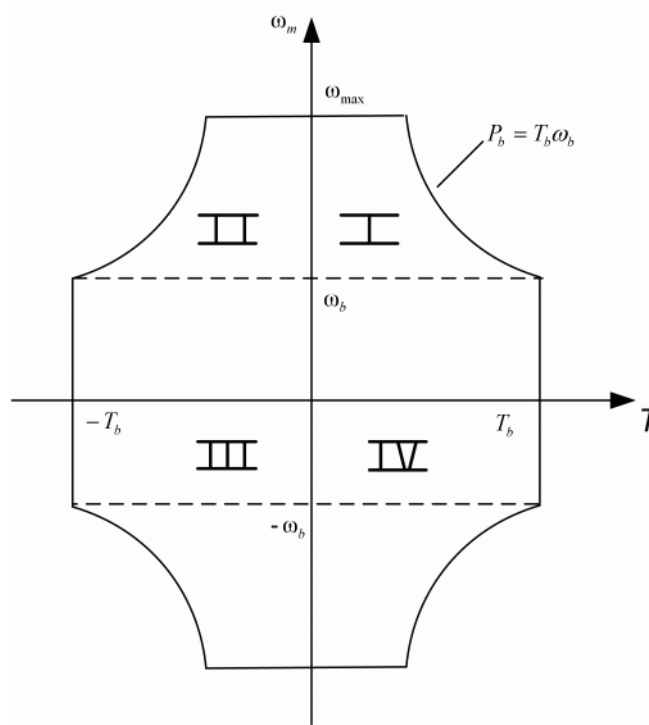

Four-Quadrant Operation of an Electric Drive

Average-Value Models

The AC and DC library allows two levels of simulation, detailed simulations or average-value simulations. The detailed simulations use the Universal Bridge block of SimPowerSystems to represent the detailed behavior of rectifier and inverter controlled drives. This simulation level requires small simulation time steps to achieve correct representation of the high frequency electrical signal components of the drives.

The average-value simulations use average-value models of the power converters. When simulating in average-value mode, the electrical input and output currents and voltages of the power converters driving the electrical motors represent the average values of the real-life currents and voltages. By doing so, the high frequency components are not represented and the

simulations can use much bigger time steps. Each power converter average-value model is described in the detailed documentation associated with each DC or AC model type. The time step used in a drive at average-value level can usually be increased up to the smallest controller sampling time used in a model. For example, if a drive uses a $20\ \mu\text{s}$ for the current loop and $100\ \mu\text{s}$ time step for the speed loop, then the simulation time step in average-value mode can be increased up to $20\ \mu\text{s}$. Simulation time step guidelines are given in the detailed documentation of each model.

Switching between the detailed simulation level and the average-value simulation level can easily be done via the new GUI associated with each model, as explained in “Selecting the Detailed or the Average-Value Model Detail Level” on page 4-12.

User Interface

The drive models supplied in the library are relatively complex and involve a large number of parameters. The Electric Drives library provides new GUIs for all models. The new GUIs offer all the functionality you would expect from existing Simulink masks, plus some new features, as outlined below.

General Layout of the Library's GUIs

The general layout of the GUIs is identical to the layout of Simulink masks. A short description of the model appears at the top, parameters are entered in the middle portion, and buttons are placed at the bottom.

The parameters section is divided in three tabs at the top level, for all drive models supplied in the library. You enter parameters related to the electric machine, converters and DC bus, and controller in the first, second and third tabs, respectively. The following figure illustrates the **Self-Controlled Synchronous Motor Drive** GUI with the **Controller** tab active.

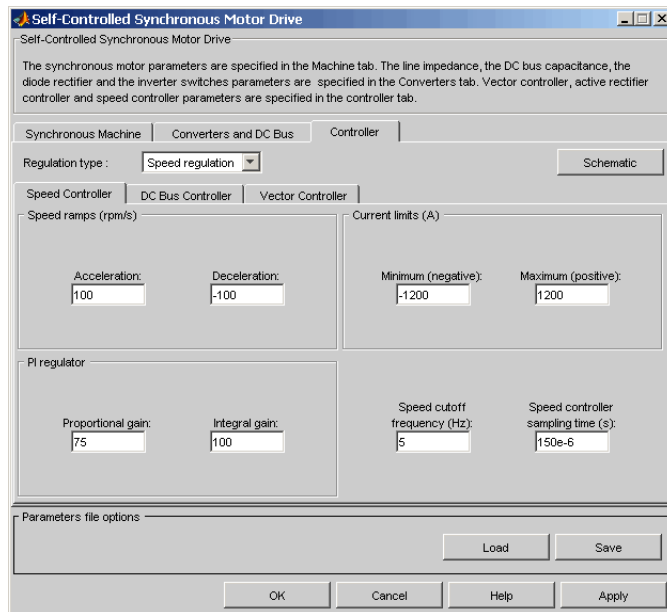

Features of the New GUIs

The new GUIs offer the same functionality as Simulink masks. You can enter as parameters numerical values, valid MATLAB expressions, and MATLAB variables. An important difference between these GUIs and Simulink masks is that you can only enter a single value in each input field (e.g. vectors and arrays are not allowed).

The new features (with respect to Simulink masks) are outlined below.

Parameter Validation

The new GUIs are designed to signal invalid parameters as early as possible. Hence, if you enter an invalid constant (for example 1.2.3 or --2) in a drive model's GUI, an error will be flagged as soon as you move away from the invalid parameter (for instance if you try to change another parameter in the GUI). Variables are treated slightly differently. If you enter a variable name that has yet not been defined in the MATLAB workspace, parameter validation is deferred until you start the simulation of the diagram that contains the model.

Saving Parameters in a File

You can see in the previous figure that the GUIs include the usual buttons found at the bottom of Simulink masks, plus two new ones, **Load** and **Save**. The **Save** button enables you to save in a file the complete set of parameters of the GUI. The format of the file is the standard MATLAB binary (.MAT) format. The **Load** button enables you to recover a previously saved set of parameters for a given drive type (e.g., AC1, DC2, etc.). When you load a set of parameters, the drive type of the saved parameters is compared to the drive type of the model you are loading the parameters into, to ensure that you are loading parameters compatible with the model.

When you use the **Load** button, the dialog that appears will point to the directory in your MATLAB installation that contains the standard sets of parameters supplied for all the drives in the library.

However, when you use the **Save** button, the dialog that appears will point to the current working directory in the MATLAB workspace.

Displaying the Controller's Schematic

There is a **Schematic** button in the top right corner of the controller tab in all drive models. When you click this button, the control schematic of the drive model will appear in a new window.

Selecting the Detailed or the Average-Value Model Detail Level

You can select the detailed or the average-value simulation level by using the **Model detail level** menu located in the lower part of the GUI. Remember to modify the simulation time step with respect to the model detail level used.

Advanced Usage

It is important to note that if you decide to disable the link between a drive model and its library, the new GUI will no longer be available for that particular instance of the model. Double-clicking on the model in such conditions will simply open the subsystem, as in the case of an unmasked Simulink subsystem. You can then enter parameters in the individual masks of subsystems that the drive model is composed from.

Note that in the “standard” (e.g., linked) situation, these masks are disabled to ensure that the top-level GUI is the only place where parameters can be changed. This is required to ensure proper synchronization of the two levels of user interfaces (e.g., the new GUI and the underlying subsystems' masks).

Simulating a DC Motor Drive

In this section, you will learn how to use the DC drive models of the SimPowerSystems Electric Drives library. First, we will specify the types of motor, converters, and controllers used in the seven DC drive models of the library, designated DC1 to DC7. These seven models are based on the DC brush motor in the Electric Drives library. As in any electric motor, the DC brush motor has two main parts, the stator (fixed) part and the rotor (movable) part. The DC brush motor also has two types of windings, the excitation or field winding and the armature winding. As its name implies, the field winding is used to produce a magnetic excitation field in the motor whereas the armature coils carry the induced motor current. Since the time constant (L/R) of the armature circuit is much smaller than that of the field winding, controlling speed by changing armature voltage is quicker than changing the field voltage. Therefore the excitation field is fed from a constant DC voltage source while the armature windings are fed by a variable DC source. The latter source is produced by a phase-controlled thyristor converter for the DC1 to DC4 models and by a transistor chopper for the DC5, DC6, and DC7 models. The thyristor converter is fed by a single-phase AC source in the cases of DC1 and DC2 and by a three-phase AC source in the cases of DC3 and DC4. Finally, the seven DC models can work in various sets of quadrants. All these possibilities are summarized in the following table.

DC Models

Model	Type of Converter	Operation Quadrants
DC1	Single-phase thyristor converter	I-II
DC2	Single-phase thyristor converter	I-II-III-IV
DC3	Three-phase thyristor converter	I-II
DC4	Three-phase thyristor converter	I-II-III-IV
DC5	Chopper	I
DC6	Chopper	I-II
DC7	Chopper	I-II-III-IV

Regenerative Braking

Operation in quadrants II and IV corresponds to forward and reverse braking, respectively. For the DC models of the Electric Drives library, this braking is regenerative, meaning that the kinetic energy of the motor-load system is converted to electric energy and returned to the power source. This bidirectional power flow is obtained by inverting the motor's connections when the current becomes null (DC1 and DC3) or by the use of a second converter (DC2 and DC4). Both methods allow inverting the motor current in order to create an electric torque opposite to the direction of motion. The chopper-fed DC drive models (DC5, DC6, DC7) produce regenerative braking in similar fashions.

Example: Thyristor Converter-Based DC Motor Drive

In this example, you will build and simulate the simple thyristor converter-based DC motor drive shown in Figure 4-1.

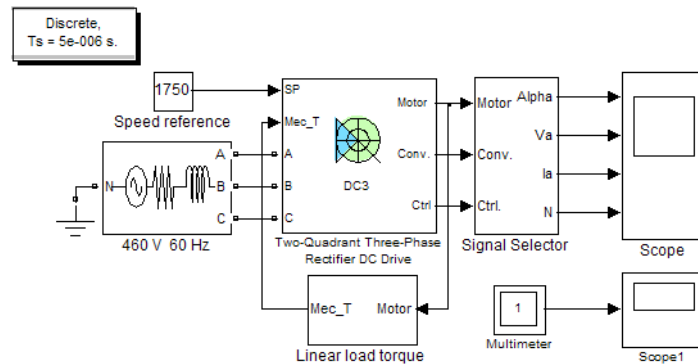

Figure 4-1: Thyristor Converter-Based DC Motor Drive Example Circuit

This step-by-step example illustrates the use of the DC3 model with a 200 hp DC motor parameter set during speed regulation. The DC3 block models a two-quadrant three-phase thyristor converter drive. During this example, the motor will be connected to a load and driven to its 1750 rpm nominal speed.

In this tutorial, you learn about

- “Getting the DC3 Model from the Drives Library” on page 4-15
- “Connecting the DC3 Model to a Voltage Source” on page 4-16
- “Connecting the DC3 Model to a Mechanical Load” on page 4-19
- “Defining the Set Point” on page 4-22
- “Visualizing Internal Signals” on page 4-22
- “Setting the Fixed-Step Simulation Environment” on page 4-25
- “Setting the High Power Drive Parameter Set” on page 4-26
- “Setting the Motor Inertia Value” on page 4-27
- “Setting the DC3 Controller Parameters and Simulation Results” on page 4-28

Getting the DC3 Model from the Drives Library

- 1 Open a new window and save it as DC_example.

- 2 Open the SimPowerSystems Electric Drives library. You can open the library by typing `electricdrivelib` in the MATLAB Command Window or by using the Simulink menu. The DC3 model is located inside the DC Drives library. Copy the DC3 block and drop it in the DC_example window.

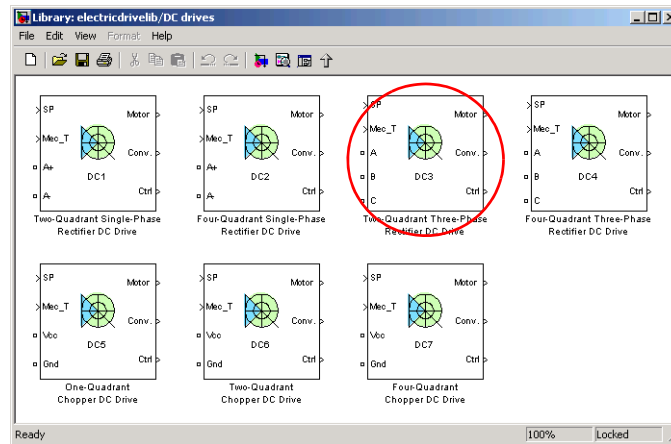
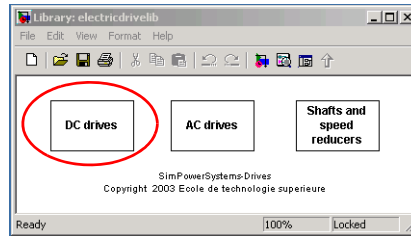

DC3 Model Inside the SimPowerSystems Electric Drives Library

Connecting the DC3 Model to a Voltage Source

All models of the library have three types of inputs: the electrical power inputs, the speed or torque set point input (SP), and the mechanical torque input (Mec_T). Because the DC3 model is a three-phase drive, it presents

three electrical inputs: A, B, and C. In order for the DC3 model to work, you must now connect those inputs to a proper voltage source:

- 1** Open the Electrical Sources library and copy the 3-Phase Source block into your circuit. Connect the voltage source outputs A, B, and C to the DC3 A, B, and C inputs, respectively.
- 2** Open the Connectors library and copy the Ground (output) block into DC_example. Connect the ground output to the 3-Phase Source neutral point N.

In this example, you are driving a 200 hp DC motor of 500 V nominal armature voltage. The mean output voltage \hat{V}_{out} of a three-phase thyristor rectifier bridge is given by

$$\hat{V}_{out} = \frac{3\sqrt{2} \cdot V_{l,rms}}{\pi} \cdot \cos \alpha$$

where $V_{l,rms}$ is the phase-to-phase rms voltage value of the three-phase voltage source and α is the firing angle value of the thyristors. For better voltage control, a lower firing angle limit is usually imposed, and the maximum mean output voltage available from the rectifier bridge is thus given by

$$\hat{V}_{out,max} = \frac{3\sqrt{2} \cdot V_{l,rms}}{\pi} \cdot \cos \alpha_{min}$$

where α_{min} is the lower firing angle limit. In our case, the lower firing angle limit used in the DC3 model is 20 degrees. With such an angle value and in order to have a maximum mean output voltage value of 500 V to drive the 200 hp motor to its nominal speed, the needed phase-to-phase rms voltage value given by the preceding equation is 370 V. Assuming the drive is connected to an American electrical network, the closest standard voltage value is 460 V.

- 3** Set the AC source phase-to-phase rms voltage value to 460 V and the frequency to 60 Hz. Name the AC source 460 V 60 Hz.

Note that the voltage source amplitude and frequency values needed for each drive model of the Electric Drives library can be found in the

reference notes. The nominal values of the corresponding motors are also included. Table 4-1 contains the values corresponding to the DC3 200 hp model.

Table 4-1: DC3, 200 HP Drive Specifications

Drive Input Voltage		
	Amplitude	460 V
	Frequency	60 Hz
Motor Nominal Values		
	Power	200 hp
	Speed	1750 rpm
	Voltage	500 V

In order to represent a real-life three-phase source, you must specify correct source resistance R and inductance L values. To determine these, one usually uses the short-circuit power value P_{sc} and a given X/R ratio (where $X = L \cdot \omega$, ω being the angular frequency of the voltage source). As a rule of thumb, the short-circuit power absorbed by the source impedance is supposed to be at least 20 times bigger than the nominal power of the drive, and the X/R ratio is usually close to 10 for industrial plants.

The value of the source impedance Z is obtained by

$$Z = \frac{V^2}{P_{sc}}$$

where V is the phase-to-phase rms voltage value of the voltage source. For a high X/R ratio r , the source resistance R is approximately equal to

$$R = \frac{Z}{r} \tag{4-1}$$

and the source inductance L to

$$L = \frac{Z}{\omega} \quad (4-2)$$

In this example, the phase-to-phase rms voltage is worth 460 V and the source frequency is 60 Hz. If we assume a short-circuit power of 25 times the nominal drive power, we find a source impedance of 0.056 Ω . For an X/R ratio of 10, using Equation 4-1 and Equation 4-2, we find a resistance value of 0.0056 Ω and an inductance value of 0.15 mH.

- 4 Set the AC source resistance value to 0.0056 Ω and the inductance to 0.15 mH.

Connecting the DC3 Model to a Mechanical Load

The Mec_T input represents the load torque applied to the shaft of the DC motor. If the values of the load torque and the speed have opposite signs, the acceleration torque will be the sum of the electromagnetic and load torques. Many load torques are proportional to the speed of the driven load such as represented by the equation

$$T_{mec} = K \cdot \omega_m = K' \cdot N_m \quad (4-3)$$

where ω_m is the speed in rad/s and N the speed in rpm. You will now build such a load.

To compute this type of mechanical load torque, the speed of the DC motor is needed. This one can be obtained by using the outputs of the DC3 model. All drive models of the Electric Drives library have three output vectors: Motor, Conv., and Ctrl. The Motor vector contains all motor-related variables, the Conv. vector contains all converter voltage and current values, and the Ctrl vector contains all the regulation important values, such as the speed or torque reference signals, the speed or torque regulation error, the firing angle value, etc. All input-output descriptions are available in the reference notes of every model.

For the mechanical load torque, you can obtain the speed by using the Motor output. When you are using a DC motor, this vector is composed of the armature voltage and of the DC motor m vector, as shown in Figure 4-2.

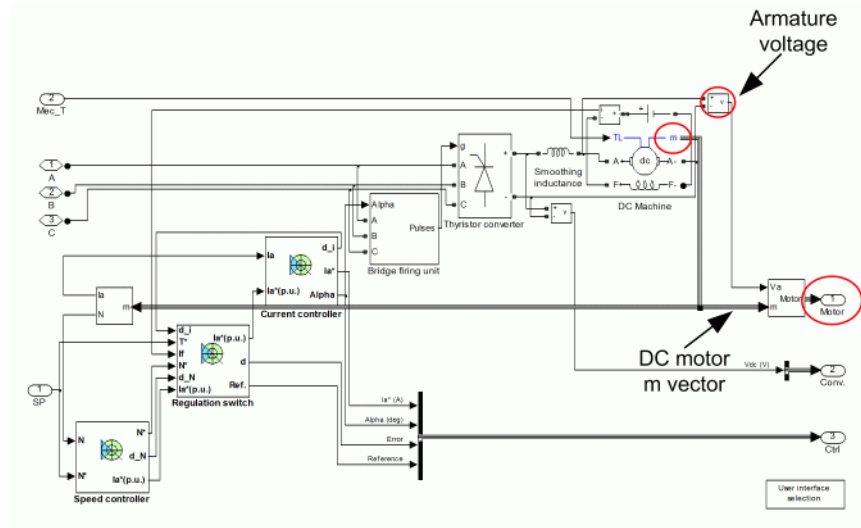

Figure 4-2: The Motor Vector

The Motor vector contains the following:

- The armature voltage
- The motor speed in rpm (the speed is converted from rad/s to rpm)
- The armature current
- The field current
- The electromagnetic torque

The speed is thus obtained by extracting the second element of the Motor vector. The speed is then multiplied by the constant K of Equation 4-3 to obtain the load torque signal to be connected to the Mec_T input of the DC3 model:

1 Build the subsystem following and name it Linear load torque.



Linear Load Torque Subsystem

The constant K can be computed knowing that at nominal speed, the motor should develop nominal torque. As shown in Table 4-1, the DC motor used in this simulation has a nominal speed $N_{m,n}$ of 1750 rpm. Since the nominal mechanical output power $P_{m,n}$ of the motor is 200 hp, the nominal mechanical load torque $T_{mec,n}$ can be computed following Equation 4-4 (where viscous friction is neglected)

$$P_{m,n} = T_{mec,n} \cdot \omega_{m,n} = T_n \cdot \frac{\pi \cdot N_{m,n}}{30} \quad (4-4)$$

where $\omega_{m,n}$ is the nominal speed in rad/s. Using this equation, we find a nominal mechanical torque of 814 N.m. Finally Equation 4-3 gives us a K value of 0.47.

- 2 Set the constant value of the Linear load torque block to 0.47.
- 3 Connect the input and output of the Linear load torque block to the Motor output vector and Mec_T input of the DC3 block, respectively. Your schematic should now look like the following.

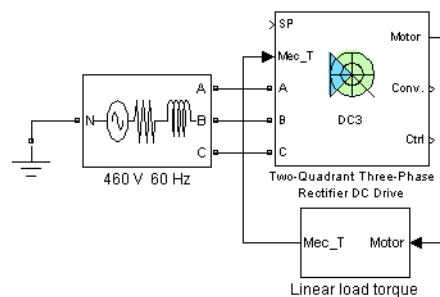

Building the Example Circuit

Defining the Set Point

The set point input of the DC3 model can either be a speed value (in rpm) or a torque value (in N.m) depending on the regulation mode (speed or torque regulation). In this example, we will set the DC3 block in speed regulation mode and drive the 200 hp DC motor to its nominal speed of 1750 rpm.

- 1 Open the Simulink Sources library and copy a Constant block into DC_example.
- 2 Connect the Constant block to the set point input of the DC3 model and name it Speed reference.
- 3 Set the set point to 1750 rpm.

Visualizing Internal Signals

You must now use the DC3 model outputs to visualize interesting signals with a scope. Suppose you need to visualize the following signals:

- The thyristor bridge firing angle
- The motor armature voltage
- The motor armature current and reference
- The speed reference and the motor speed

Note that all model input-output descriptions can be found in the corresponding reference notes. To see which signals are connected to the DC3 outputs, select the DC3 model and use the **Edit/Look Under Mask** menu.

As you can see below, the firing angle is contained inside the Ctrl output vector. The firing angle Alpha (see the DC3 block reference notes) is the second element of this vector.

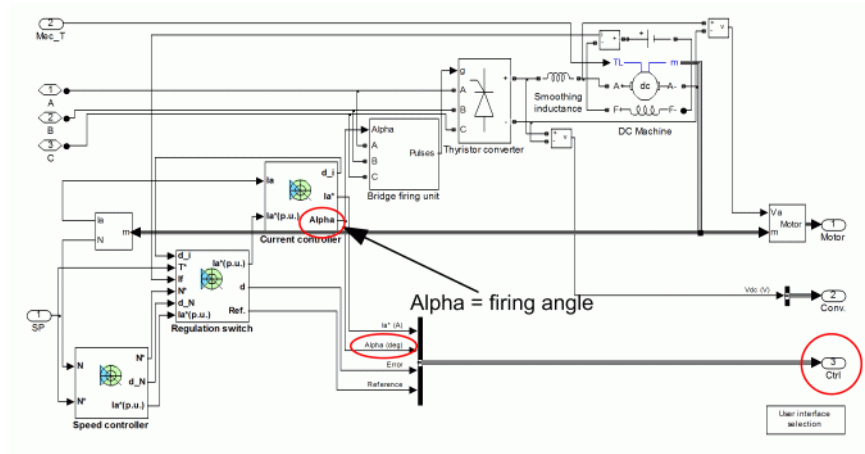

Location of the Firing Angle Signal Inside the Ctrl Output Vector

The Motor vector contains three of the needed signals: the armature voltage and current signals are the first and third elements, respectively (Figure 4-2). The speed is the second element of the Motor vector.

Finally, the current and speed reference signals are the first and fourth elements of the Ctrl vector, respectively (see the following figure). Note that the Ref. signal of the Regulation switch block would be a torque reference in torque regulation mode.

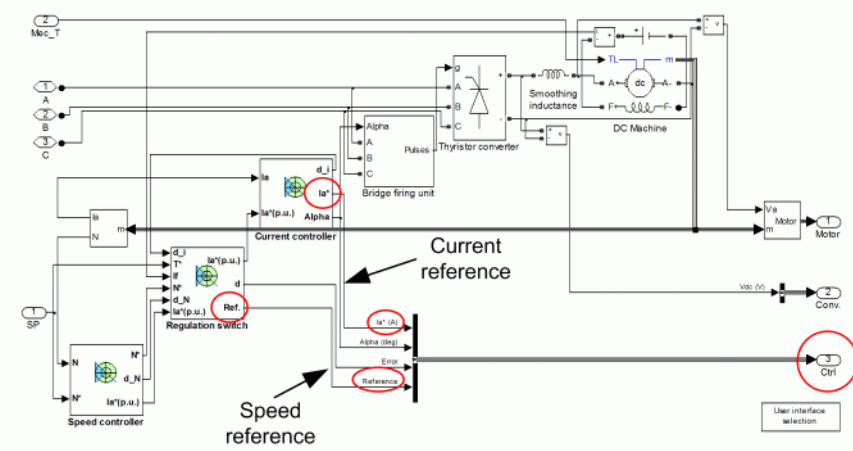

Location of the Speed Reference Signal Inside the Ctrl Output Vector

Internal bridge current and voltage signals can be extracted via the Conv. output, which is connected to a multimeter output. By clicking the Multimeter block, you can select the converter signals you want to output. Refer to the Multimeter block reference page for more information on how to use the Multimeter block.

By using Selector blocks of the Signal Routing library, you can now extract the needed signals from the three output vectors in order to visualize them:

- 1 Build the subsystem following in order to extract all the needed visualization signals. Name it Signal selector.

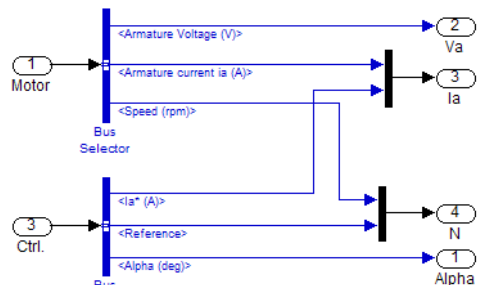

Signal Selector Subsystem

- 2 Connect the Motor, Conv., and Ctrl outputs of the DC3 block to the Motor, Conv., and Ctrl inputs of your Signal selector block.
- 3 Copy a scope to your model. It will be used to display the output signals of the Signal Selector block. Open the **Scope Parameters** dialog box. On the **General** tab, set the number of axes to 4, the simulation time range to auto, and use a decimation of 20. Clear the **Limit Data Points to last** check box on the **Data history** tab. Connect the four outputs of the Signal Selector block to the inputs of the scope.

Setting the Fixed-Step Simulation Environment

All drive models of the library are discrete models. In order to simulate your system, you must now specify the correct simulation time step and set the fixed-step solver option. Recommended sample time values for DC drives, AC drives, and mechanical models can be found in the Remarks sections of the corresponding block reference pages. The recommended sample time for the DC3 model is 5 μ s. Follow these steps:

- 1 Open the SimPowerSystems library and copy a Powergui block into DC_example. Set the Sample Time to 5 μ s.

Your circuit should now look like Figure 4-1.

- 2 Open the **Simulation/Configuration Parameters** dialog box. Select the fixed-step, discrete (no continuous states) solver option. Set the stop time to 12 seconds.

Before simulating your circuit, you must first set the correct DC3 internal parameters.

Setting the High Power Drive Parameter Set

Many models of the Electric Drives library have two sets of parameters: a low-power set and a high-power set. By default, all models are initially loaded with the low-power set. The DC3 model parameters currently loaded in DC_example are those of a 5 hp drive.

You will now set the high-power drive parameters, which are those of a 200 hp drive. To do this, you will use the graphical user interface:

- 1 Open the user interface by double-clicking the DC3 block. The interface is shown.

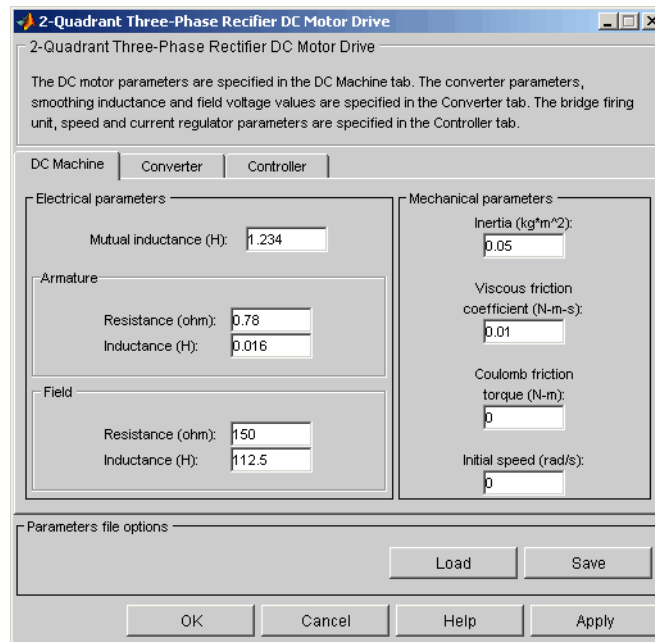

DC3 User Interface

The interface is divided following the three main parts of a drive system: the motor parameters (**DC Machine** tab), the converter parameters

(**Converter** tab), and the regulation parameters of the drive controller (**Controller** tab).

- 2 To load the 200 hp parameters, click the **Load** button.

When you click the **Load** button, a window containing the low-power and high-power parameter files of every AC and DC model appears. These files contain all the parameters used by the graphical user interface. The name of each file is composed of the model name followed by the power value. The 200 hp version of DC3 is thus named DC3_200hp.

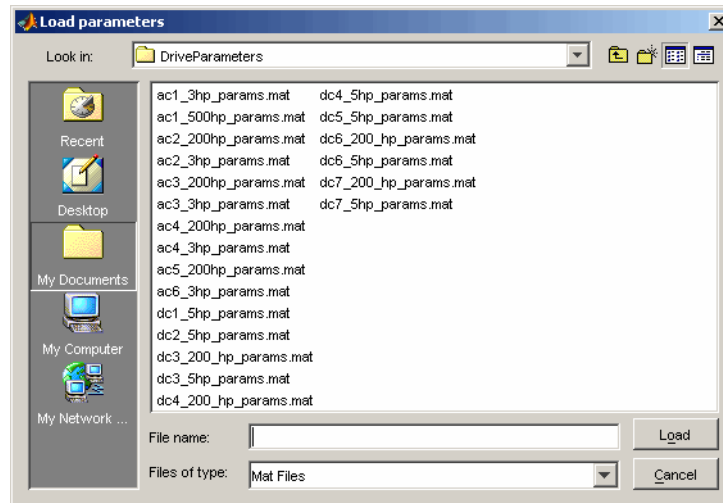

Parameters Selection Window

- 3 In the parameters selection window, select the DC3_200hp.mat file and click **Load**.

The 200 hp parameters are now loaded. Note that you can also save custom drive parameters by using the **Save** button. When you do so, your custom parameters are saved in a MAT-file format and can be reloaded at any time.

Setting the Motor Inertia Value

All default inertias of the library drives are “no-load” inertias that only represent rotor inertias. When the motor is coupled to a load, the inertia field of the **DC Machine** tab represents the combined inertias of the rotor and of

the driven load. In this example, the no-load inertia of the DC3 200 hp motor is 2.5 kg.m². Since the drive is directly coupled to a load, you must increase this value by the inertia of the load. Suppose that the new combined inertia amounts to 15 kg.m².

- 1 In the **DC Machine** section of the dialog box, change the inertia value to 15 kg.m².
- 2 Click **OK** to apply the changes and close the dialog box.

Setting the DC3 Controller Parameters and Simulation Results

The speed and current controllers of the DC3 block are both composed of a proportional-integral regulator. More details on the regulators of each drive model of the library can be found in the corresponding reference notes. To have a quick idea of the internal structure of a drive controller, a schematic is available inside the user interface of each model. Let's open the schematics related to our DC3 model:

- 1 Open the user interface. Click the **Controller** section and then the **Schematic button**. You should see the controller schematics of Figure 4-3.

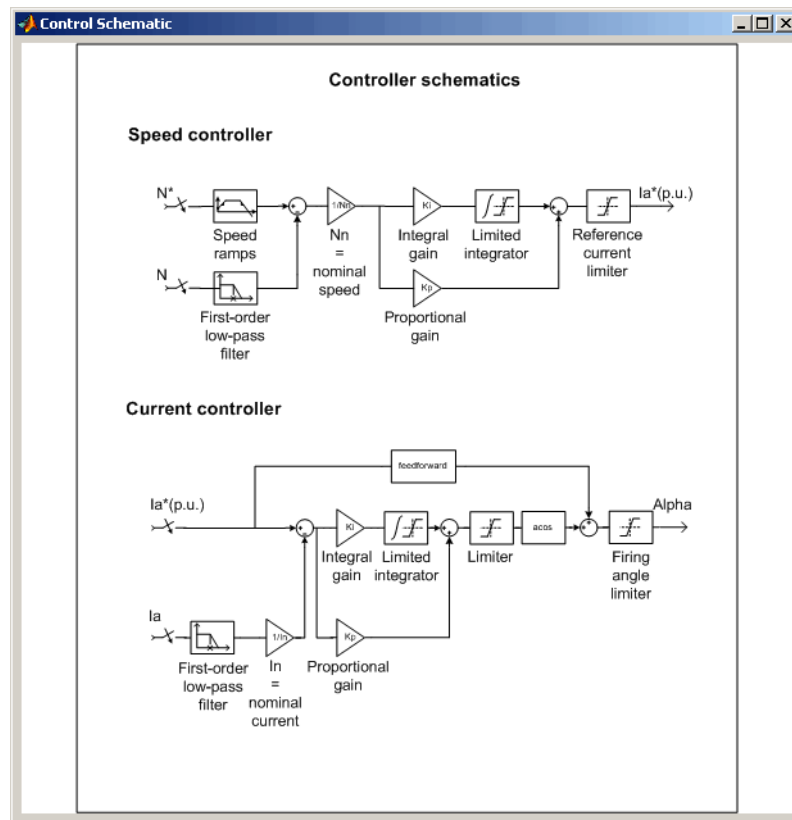
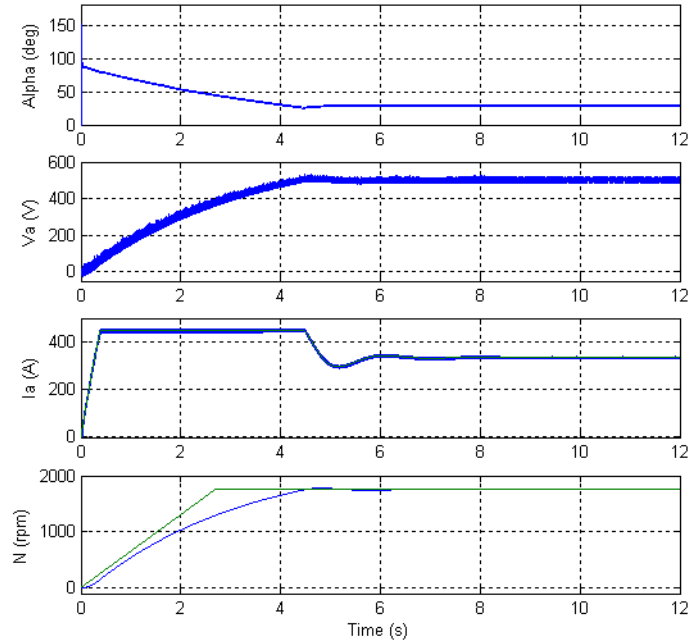

Figure 4-3: Controller Schematics of the User Interface

All default regulation parameters (speed and current controller parameters) have been trimmed for “no-load” inertias. Because the inertia has been modified, some changes are needed regarding the speed controller. The current controller should not be modified, the change of inertia having little influence on the current control.

In order to visualize the changes that need to be made, run a simulation of the present circuit.

- 2** Start the simulation. The simulation results visualized on the scope are shown below.



Simulation Results

Notice that the armature current follows its reference very well, but saturates at 450 A during the accelerating phase. This saturation is a result of the current controller reference limit of 1.5 p.u. This results in insufficient acceleration torque, and the motor is unable to follow the 650 rpm/s default speed ramp. Since the acceleration torque cannot be increased (this would result in a burnout of the armature circuit), the speed ramp must be lowered. A rule of thumb is to lower the speed ramp by the same amount that the inertia was increased. Indeed, following the equation below, the same torque vs. speed curve (or current vs. speed) as the default one obtained with a 2.5 kg.m² inertia can be obtained with the new inertia I , if the speed ramp $\dot{\omega}$ is reduced by an amount equal to the inertia increase.

$$T_{em}(\omega) = I \cdot \dot{\omega} + T_{mec} + B \cdot \omega = I \cdot \dot{\omega} + K' \cdot \omega + B \cdot \omega$$

The $B \cdot \omega$ term represents the viscous friction in the drive where B is the viscous friction coefficient.

In this case, we decrease the speed ramp slightly less than the inertia increase in order to have a high enough acceleration, and set it to 200 rpm/s.

- 3 Open the user interface. In the **Controller** section, set the acceleration speed ramp parameter of the speed controller menu to 200 rpm/s.

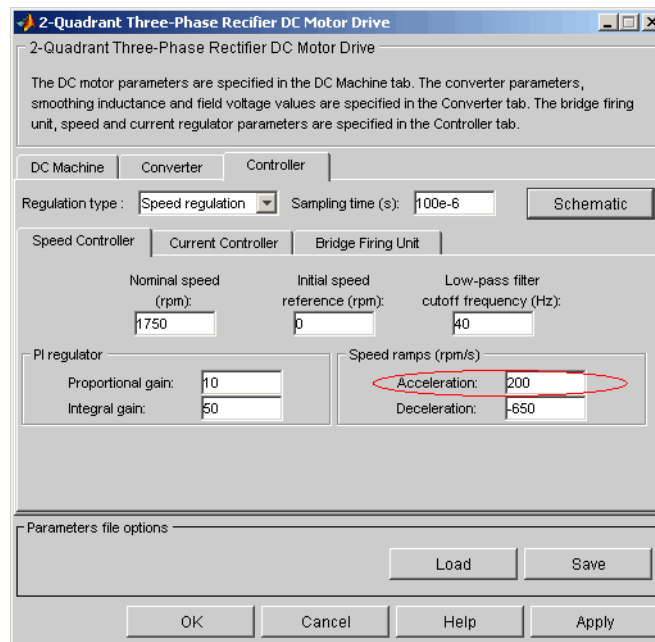

Change of the Acceleration Speed Ramp Parameter

- 4 Start the simulation and observe the new results on the scope.

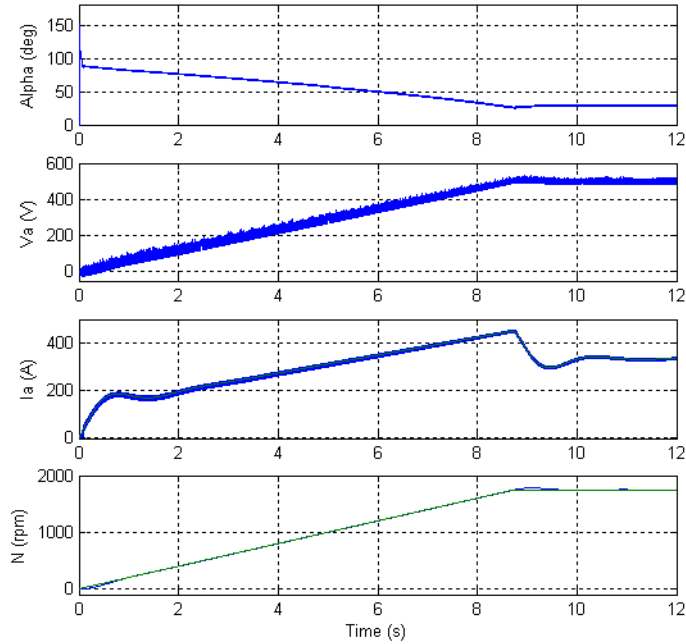

Simulation Results with a New Acceleration Speed Ramp Value

The current regulation is very good, and no current regulator changes will be undertaken. The speed regulation is satisfactory, but some improvements could be made: the initial tracking of the speed reference could be faster, and the speed overshoot and the small speed ramping error encountered during the accelerating phase could be reduced. A modification of the proportional and integral gains of the PI speed regulator will allow you to achieve these goals:

- By increasing the proportional gain of the speed controller, you increase the controller's sensitivity by making it react a lot faster to small speed regulation errors. This allows a better initial tracking of the speed reference by a faster reaction of the current reference issued by the speed controller. This increased sensitivity also reduces the speed

overshooting, the armature current being reduced a lot faster once the desired speed is reached.

- An increase of the integral gain will allow the motor speed to catch up with the speed reference ramp a lot faster during ramping periods. This will indeed allow a faster reaction to small speed error integral terms that occur when a signal is regulated following a ramp. The controller will react in order to diminish the speed error integral a lot faster by producing a slightly higher acceleration torque when following an acceleration ramp.

Be aware that too high an increase of the proportional and integral gains can cause instability, the controller becoming oversensitive. Too high gains can also cause current saturation. An easy way to adjust the speed controller gains is to increase them step by step and to simulate the new configuration after each change until the desired system performances are obtained (trial/error method).

Note that when the current controller has to be trimmed, a good way to achieve this is to keep the rotor still by setting a very high combined inertia value. This allows a decoupling of the electrical and mechanical parameters. You then adjust the current controller parameters until the current follows given current references perfectly. The same remarks can be made for the current regulator as those made above for speed regulation. Once the current regulator is trimmed, you can then trim the speed regulator by resetting the combined inertia to its initial value.

- 5 Try different speed regulator values and observe the resulting changes in the system dynamics. A proportional gain of 80 and an integral gain of 200 give very good results, as shown.

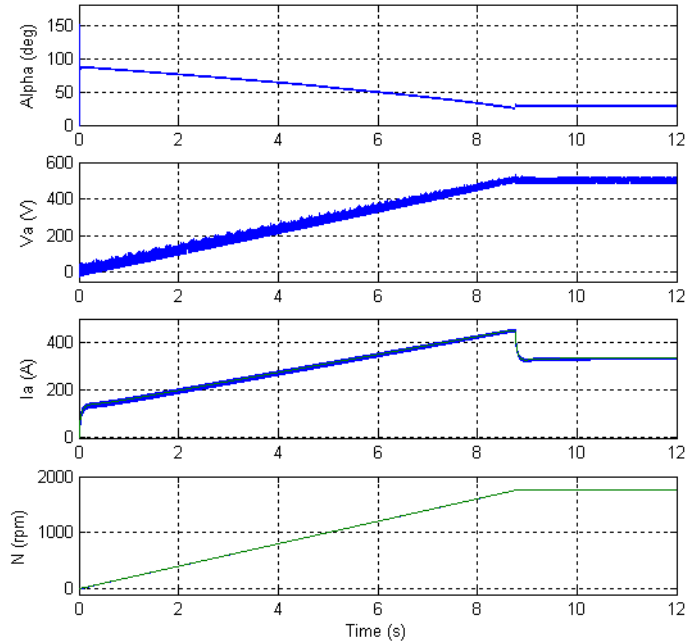

Simulation Results with Trimmed Speed Regulator Parameters

Observe that the firing angle value lowers with the speed increase in order to generate a growing converter output voltage. The converter is here working in rectifier mode, the power transiting from the AC source to the DC motor. The voltage increase allows the converter to keep feeding current to the DC motor during the acceleration phase, the armature voltage increasing proportionally with the speed. The current increase observed during this phase is due to the increasing torque opposed by the load. Around $t = 8.5$ s, the speed reaches its set point, and the armature current lowers to about 335 A since no more acceleration torque is needed.

Before concluding this example, notice the two first-order filters used in the speed and current controllers of Figure 4-3. These filters remove unwanted current and speed harmonics in the current and speed measurement signals. These harmonics are caused by the rectified output voltages of the three-phase full converters. The main ripple frequency introduced by a

three-phase full converter is equal to six times the voltage source frequency (6th harmonic). In the case of this example, the first harmonic frequency is thus equal to 360 Hz. The cutoff frequency of the first-order filters must at least be lower than 360 Hz. Since the filters are first-order filters, the cutoff frequency must be a lot lower to have a reasonably good harmonic rejection. Keep in mind that too low a cutoff frequency can cause system instability. In the case of chopper drives like DC5, DC6, and DC7, the fundamental frequency is equal to the PWM frequency.

Simulating in Average-Value Mode

Every model can be simulated in average-value mode. In such mode, the Universal Bridge blocks used to simulate the power converters driving the motors are replaced by average-value converters. The average-value converter models used are described in the reference pages of each drive model. This lets you increase the simulation time step and thus increase simulation speed.

Use the following procedure to simulate a model in average-value mode.

- 1 Open the user interface. Select the Average option in the **Model detail level** drop-down list located in the lower part of the user interface, as shown in the following illustration.

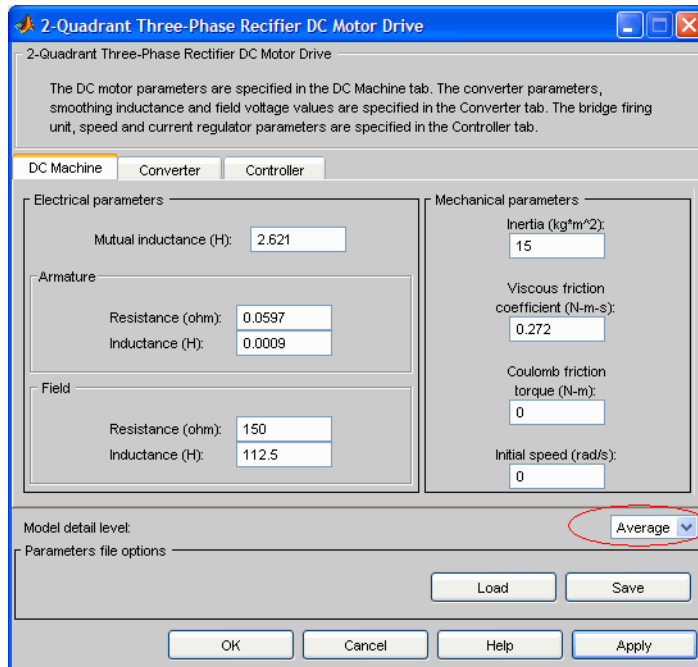

Selecting the Average-Value Simulation Mode

2 Select the **Converter** section.

Notice that it contains some extra parameters specific to average-value mode. These parameters affect the external voltage source and are used by the average-value rectifier. All parameters are described in the reference pages.

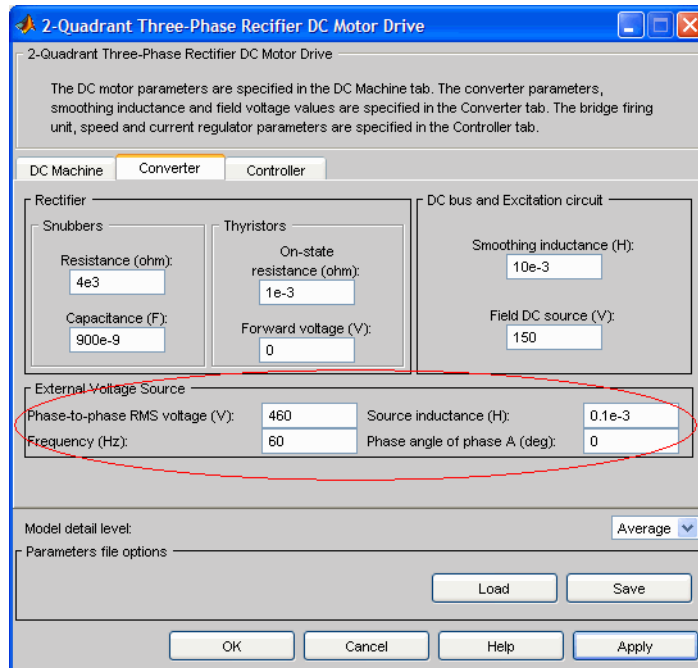

Extra Parameters Used in Average-Value Mode

When simulating in average-value mode, the time step can be increased in order to run faster simulations. A guideline is to increase the time step up to the smallest controller sampling time used in the model. In this case the sampling time is the same for the speed and current controllers and is equal to $100\mu\text{s}$.

- 3 Close the user interface and open the Powergui block. Set the **Sample Time** to $100\mu\text{s}$. Run the simulation.

Notice that the simulation time is reduced. Observe the simulation results: the rectifier output voltage and current ripples are not represented, you can see only the average value of these signals. If you later try to visualize the input current, you will only see the 60 Hz fundamental component of the detailed current.

Simulating an AC Motor Drive

In this section, you will learn how to use the AC drive models of the SimPowerSystems Electric Drives library. First, we will specify the types of motors, converters, and controllers used in the six AC drive models of the library designated AC1 to AC6. The AC1, AC2, AC3, and AC4 models are based on the three-phase induction motor. This motor has a three-phase winding at the stator and a wound rotor or a squirrel-cage rotor. The squirrel-cage rotor consists of slots of conducting bars embedded in the rotor iron. The conducting bars are short-circuited together at each end of the rotor by conducting rings. The AC5 model is based on a wound rotor synchronous motor, and the AC6 model uses a permanent magnet synchronous motor. The models of these three types of motors are available in the SimPowerSystems Machines library. These AC motors are fed by a variable AC voltage and frequency produced by an inverter. The type of inverter used in the six AC drive models is a voltage source inverter (VSI) in the sense that this inverter is fed by a constant DC voltage. This constant voltage is provided by an uncontrolled diode rectifier and a capacitor (capacitive DC bus voltage).

Dynamic Braking

When the DC bus is provided by a diode rectifier, the drive doesn't have a bidirectional power flow capability and therefore cannot perform regenerative braking. In the AC1, AC2, AC3, AC4, and AC6 models, a braking resistor in series with a chopper ensures the braking of the motor-load system. This braking scheme is called dynamic braking. It is placed in parallel with the DC bus in order to prevent its voltage from increasing when the motor decelerates. With dynamic braking, the kinetic energy of the motor-load system is converted into heat dissipated in the braking resistor.

Modulation Techniques

The VSI inverters used in the AC drive models of the library are based on two types of modulation, hysteresis modulation and space vector pulse width modulation (PWM).

The hysteresis modulation is a feedback current control method where the motor current tracks the reference current within a hysteresis band. The following figure shows the operation principle of the hysteresis modulation. The controller generates the sinusoidal reference current of desired magnitude and frequency that is compared with the actual motor line

current. If the current exceeds the upper limit of the hysteresis band, the upper switch of the inverter arm is turned off and the lower switch is turned on. As a result, the current starts to decay. If the current crosses the lower limit of the hysteresis band, the lower switch of the inverter arm is turned off and the upper switch is turned on. As a result, the current gets back into the hysteresis band. Hence, the actual current is forced to track the reference current within the hysteresis band.

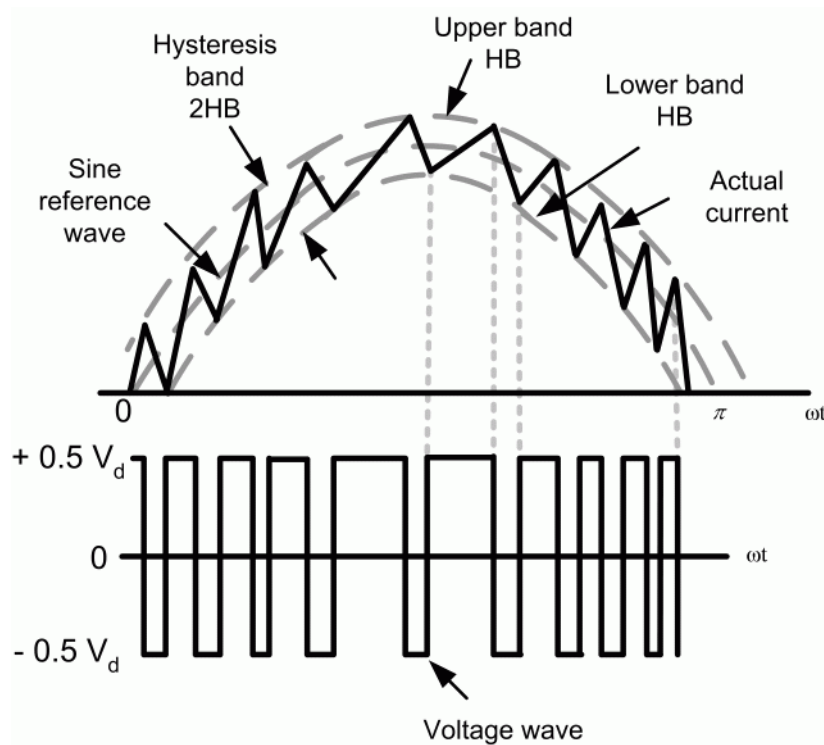

Operation Principle of Hysteresis Modulation

The following figure shows the hysteresis current control modulation scheme, consisting of three hysteresis comparators, one for each phase. This type of closed-loop PWM is used in AC3 and AC5 models.

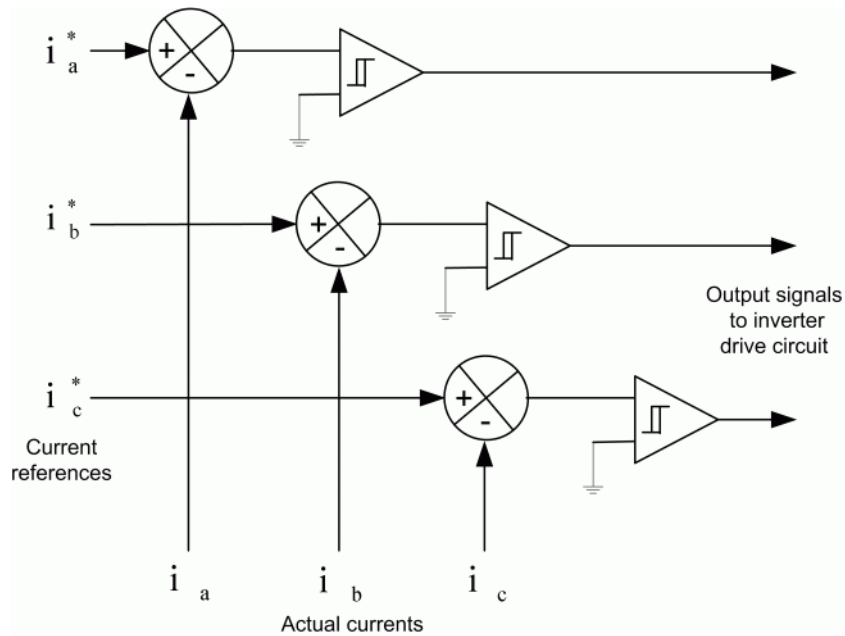

Typical Hysteresis Current Controller

The space vector modulation technique differs from the hysteresis modulation in that there are not separate comparators used for each of the three phases. Instead, a reference voltage space vector V_s is produced as a whole, sampled at a fixed frequency, and then constructed through adequate timing of adjacent nonzero inverter voltage space vectors V_1 to V_6 and the zero voltage space vectors V_0 , V_7 . A simplified diagram of a VSI inverter is shown below. In this diagram, the conduction state of the three legs of the inverter is represented by three logic variables, SA, SB, and SC. A logical 1 means that the upper switch is conducting and logical 0 means that the lower switch is conducting.

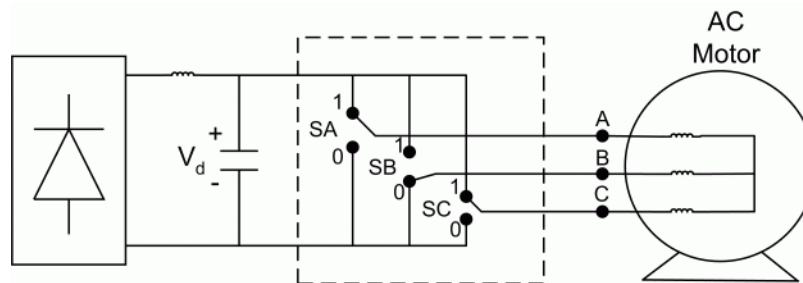

Simplified Diagram of a VSI PWM Inverter

The switching of SA, SB, SC results in eight states for the inverter. The switching states and the corresponding phase to neutral voltages are summarized in Table 4-2. The six active vectors are an angle of 60 degrees apart and describe a hexagon boundary. The two zero vectors are at the origin.

For the location of the V_s vector shown in Figure 4-4, as an example, the way to generate the inverter output is to use the adjacent vectors V_1 and V_2 on a part-time basis to satisfy the average output demand. The voltage V_s can be resolved as

$$V_b = \frac{2}{\sqrt{3}} V_s \sin \delta$$

$$V_a = V_s \cos \delta - \frac{1}{2} V_b$$

where V_a and V_b are the components of V_s along V_1 and V_2 , respectively. Considering the period T_c during which the average output should match the command, we can write the time durations of the two states 1 and 2 and the zero voltage state as

$$t_a = \frac{3}{2} \cdot \frac{V_a}{V_d} \cdot T_c$$

$$t_b = \frac{2}{3} \cdot \frac{V_b}{V_d} \cdot T_c$$

$$t_z = T_c - (t_a + t_b)$$

Table 4-2: Inverter Space Voltage Vectors

State	SA	SB	SC	Inverter Operation	Space Voltage Vector
0	1	1	1	Freewheeling	V_0
1	1	0	0	Active	V_1
2	1	1	0	Active	V_2
3	0	1	0	Active	V_3
4	0	1	1	Active	V_4
5	0	0	1	Active	V_5
6	1	0	1	Active	V_6
7	0	0	0	Freewheeling	V_7

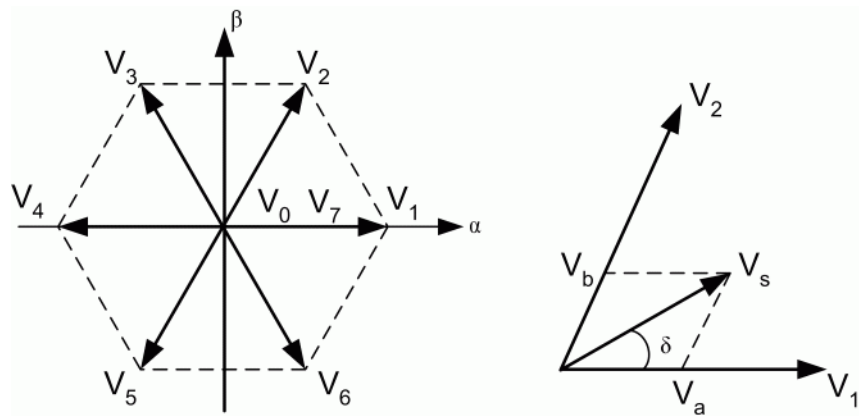

Figure 4-4: Inverter Space Vector Voltages

Open-Loop Volts/Hertz Control

The AC machine stator flux is equal to the stator voltage to frequency ratio since

$$\varphi(t) = \int v(t)dt \text{ where } v(t) = \sqrt{2}V\sin(\omega t)$$

therefore

$$\varphi(t) = \frac{\sqrt{2}V}{\omega} \cos(\omega t)$$

Since the motor is fed with a variable AC source voltage and frequency, it is important to maintain the volts/Hz constant in the constant torque region if magnetic saturation is to be avoided. A typical volts/Hz characteristic is shown below. Notice that the straight line has a small voltage boost in order to compensate for resistance drop at low frequency. Open-loop volts/Hz control is used with low-dynamics applications such as pumps or fans where a small variation of motor speed with load is tolerable. The AC1 model is based on an open-loop volts/Hz controller.

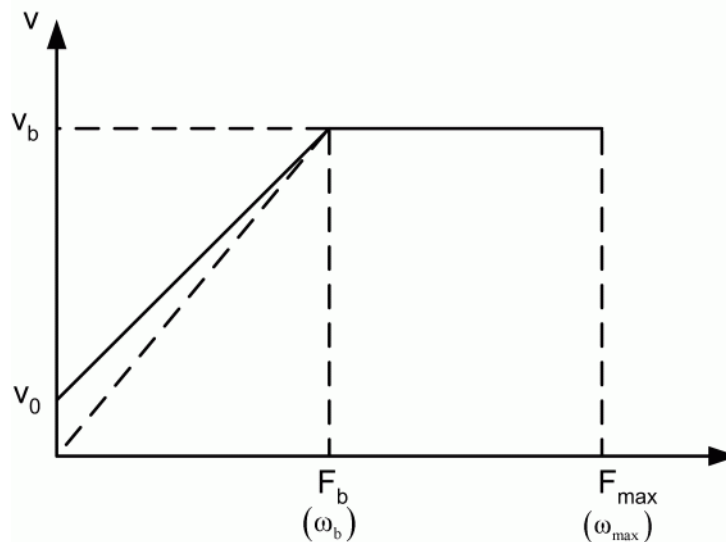

Volts/Hz Characteristics with Compensation at Low Frequency

Closed-Loop Speed Control with Slip Compensation

In this type of control, a slip speed command is added to the measured rotor speed to produce the desired inverter frequency. A PI-based speed regulator produces the slip command. The desired inverter frequency generates the voltage command through a volts/Hz characteristic such as the one shown above. The AC2 model is based on a closed-loop speed control that uses volts/Hz and slip regulation.

Flux-Oriented Control

The construction of a DC machine is such that the field flux is perpendicular to the armature flux. Being orthogonal, these two fluxes produce no net interaction on one another. Adjusting the field current can therefore control the DC machine flux, and the torque can be controlled independently of flux by adjusting the armature current. An AC machine is not so simple because of the interactions between the stator and the rotor fields, whose orientations are not held at 90 degrees but vary with the operating conditions. You can obtain DC machine-like performance in holding a fixed and orthogonal orientation between the field and armature fields in an AC machine by orienting the stator current with respect to the rotor flux so as to attain independently controlled flux and torque. Such a control scheme is called flux-oriented control or vector control. Vector control is applicable to both induction and synchronous motors. We will see now how it applies to induction motors.

Considering the d-q model of the induction machine in the reference frame rotating at synchronous speed ω_e ,

$$V_{qs} = R_s i_{qs} + \frac{d}{dt} \phi_{qs} + \omega_e \phi_{ds}$$

$$V_{ds} = R_s i_{ds} + \frac{d}{dt} \phi_{ds} - \omega_e \phi_{qs}$$

$$0 = R_s i_{qr} + \frac{d}{dt} \phi_{qr} + (\omega_e - \omega_r) \phi_{dr}$$

$$0 = R_r i_{dr} + \frac{d}{dt} \phi_{dr} - (\omega_e - \omega_r) \phi_{qr}$$

$$T_e = 1.5p \frac{L_m}{L_r} (\phi_{dr} i_{qs} - \phi_{qr} i_{ds})$$

where

$$\phi_{qs} = L_s i_{qs} + L_m i_{qr}, \quad \phi_{ds} = L_s i_{ds} + L_m i_{dr}$$

$$\phi_{qr} = L_r i_{qr} + L_m i_{qs}, \quad \phi_{dr} = L_r i_{dr} + L_m i_{ds}$$

The field-oriented control implies that the i_{ds} component of the stator current would be aligned with the rotor field and the i_{qs} component would be perpendicular to i_{ds} . This can be accomplished by choosing ω_e to be the speed of the rotor flux and locking the phase of the reference frame system such that that the rotor flux is aligned precisely with the d axis, resulting in

$$\phi_{qr} = 0 \Rightarrow \frac{d}{dt} \phi_{qr} = 0$$

and

$$\phi_{dr} = \phi_r$$

which implies that

$$\omega_{sl} = (\omega_e - \omega_r) = \left(\frac{L_m R_r}{\phi_r L_r} \right) i_{qs}$$

and that

$$T_e = 1.5p \frac{L_m}{L_r} (\phi_r i_{qs})$$

It also follows that

$$\frac{d}{dt} \phi_r = - \left(\frac{R_r}{L_r} \right) \phi_r + \left(\frac{L_m R_r}{L_r} \right) i_{ds}$$

The analogy with DC machine performance is now clear. The electric torque is proportional to the i_{qs} component, whereas the relation between the flux ϕ_r and the i_{ds} component is given by a first-order linear transfer function with a time constant L_r/R_r .

You cannot directly measure the rotor flux orientation in a squirrel-cage rotor induction machine. It can only be estimated from terminal measurements. An alternative way is to use the slip relation derived above to estimate the flux position relative to the rotor, as shown. The latter control scheme is called indirect field-oriented control and is used in the AC3 model.

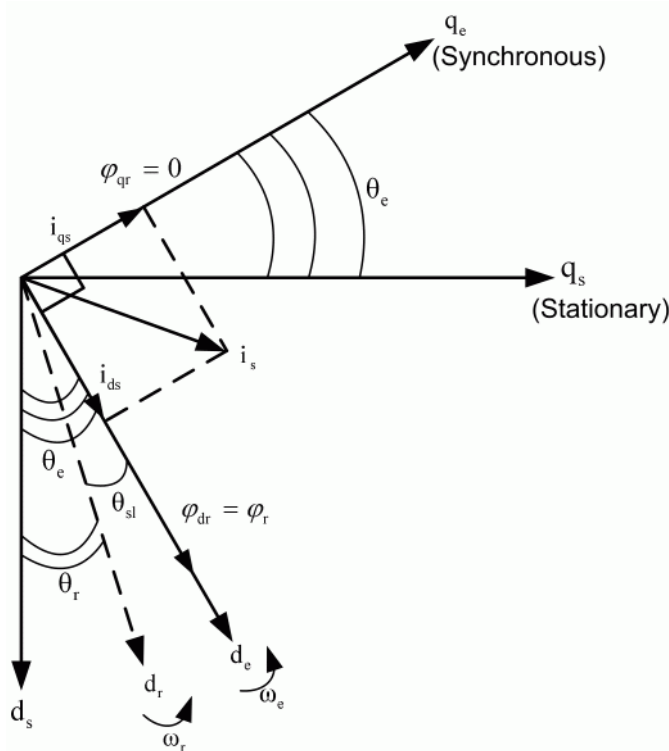

Rotor Flux Position Obtained from the Slip and Rotor Positions

Direct Torque Control

The field-oriented control is an attractive control method but it has a serious drawback: it relies heavily on precise knowledge of the motor parameters. The rotor time constant is particularly difficult to measure precisely, and to make matters worse it varies with temperature.

A more robust control method consists first in estimating the machine stator flux and electric torque in the stationary reference frame from terminal measurements. The following relations are used

$$\varphi_{ds} = \int (V_{ds} - R_s i_{ds}) dt$$

$$\varphi_{qs} = \int (V_{qs} - R_s i_{qs}) dt$$

$$\hat{\varphi}_s = \sqrt{\varphi_{ds}^2 + \varphi_{qs}^2} \angle \text{atan}\left(\frac{\varphi_{qs}}{\varphi_{ds}}\right)$$

$$T_e = 1.5p(\varphi_{ds} i_{qs} - \varphi_{qs} i_{ds})$$

The estimated stator flux and electric torque are then controlled directly by comparing them with their respective demanded values using hysteresis comparators. The outputs of the two comparators are then used as input signals of an optimal switching table. The following table outputs the appropriate switching state for the inverter.

Switching Table of Inverter Space Vectors

H_ψ	H_{T_e}	S(1)	S(2)	S(3)	S(4)	S(5)	S(6)
1	1	V_2	V_3	V_4	V_5	V_6	V_1
	0	V_0	V_7	V_0	V_7	V_0	V_7
	-1	V_6	V_1	V_2	V_3	V_4	V_5
-1	1	V_3	V_4	V_5	V_6	V_1	V_2
	0	V_7	V_0	V_7	V_0	V_7	V_0
	-1	V_5	V_6	V_1	V_2	V_3	V_4

Example: AC Motor Drive

In this example, you will build and simulate the simple induction motor drive system in Figure 4-5.

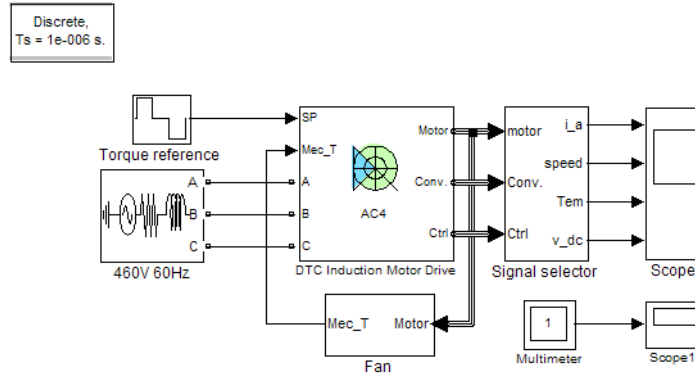

Figure 4-5: Induction Motor Drive Example Circuit

This step-by-step example illustrates the use of the AC4 model with a 200 hp induction motor parameter set during torque regulation. The AC4 block models a DTC drive. During this example, the motor is connected to a fan and its reaction to torque steps is simulated.

In this tutorial, you learn about

- “Getting the AC4 Model from the Electric Drives Library” on page 4-49
- “Connecting the AC4 Model to a Voltage Source” on page 4-50
- “Connecting the AC4 Model to a Mechanical Load” on page 4-51
- “Defining the Set Point” on page 4-53
- “Setting the Fixed-Step Simulation Environment” on page 4-57
- “Setting the Fixed-Step Simulation Environment” on page 4-57
- “Setting the High Power Drive Parameter Set” on page 4-58
- “Setting the Motor Inertia Value” on page 4-59
- “Setting the Braking Chopper Resistance Value” on page 4-60
- “Setting the DC Bus Initial Voltage Value” on page 4-61
- “Setting the AC4 Controller Parameters” on page 4-62

Getting the AC4 Model from the Electric Drives Library

- 1 Open a new window and save it as `ac_example`.
- 2 Open the Electric Drives library. You can open the library by typing `electricdrivelib` in the MATLAB Command Window or by using the Simulink menu. The AC4 model is located inside the AC drives library. Copy the AC4 block and drop it in the `ac_example` window.

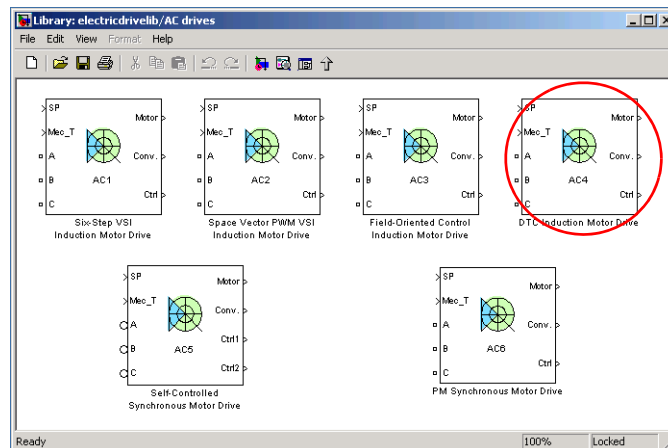
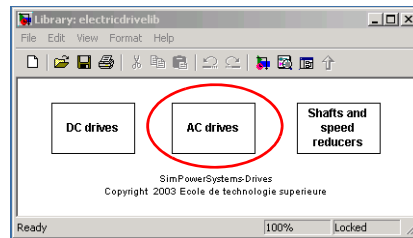

Figure 4-6: AC4 Model Inside the Drives Library

Connecting the AC4 Model to a Voltage Source

As with the DC example, you must now connect the AC4 block to a proper voltage source:

- 1 Open the Electrical Sources library and copy the Three-Phase Source block into your circuit. Connect the voltage source outputs A, B, and C to the AC4 A, B, and C inputs, respectively.
- 2 Open the Connectors library and copy the Ground (output) block into ac_example. Connect the ground output to the Three-Phase Source neutral point N.

In this example, we will be driving a 200 hp induction motor of 460 V nominal armature voltage and 60 Hz nominal frequency. As specified in the DC example, the voltage source amplitude and frequency values needed for each drive model of the Electric Drives library can be found in the reference notes. The nominal values of the corresponding motors are also included. The following table contains the values corresponding to the AC4 200 hp model.

AC4, 200 HP Drive Specifications

Drive Input Voltage		
	Amplitude	460 V
	Frequency	60 Hz
Motor Nominal Values		
	Power	200 hp
	Speed	1800 rpm
	Voltage	460 V

We will thus set the AC source voltage amplitude and frequency values to 460 V and 60 Hz, respectively.

- 3** Set the AC source phase-to-phase rms voltage value to 460 V, and the frequency to 60 Hz. Name the AC source 460 V 60 Hz.

In order to represent a real-life three-phase source, you must specify correct source resistance R and inductance L values. The procedure to determine these values has been discussed above in the step-by-step example “Connecting the DC3 Model to a Voltage Source” on page 4-16. Following this procedure, you determine a resistance value of 0.0056 Ω and an inductance value of 0.15 mH.

- 4** Set the AC source resistance value to 0.0056 Ω and the inductance to 0.15 mH.

Connecting the AC4 Model to a Mechanical Load

The Mec_T input of the AC4 block represents the load torque applied to the shaft of the induction motor. In this case, the load torque is opposed by a fan. This type of torque is typically a quadratic function of the speed, as shown in Equation 4-5:

$$T_{mec} = K \cdot \omega_m^2 = K \cdot N_m^2 \quad (4-5)$$

where ω_m is the speed in rad/s N_m and the speed in rpm. You will now build such a load.

To compute the mechanical load torque, the speed of the induction motor is needed. As discussed in the DC example, the speed value can be obtained from the Motor output vector of the AC4 model. As shown, the Motor vector is composed of the m output vector of the induction motor.

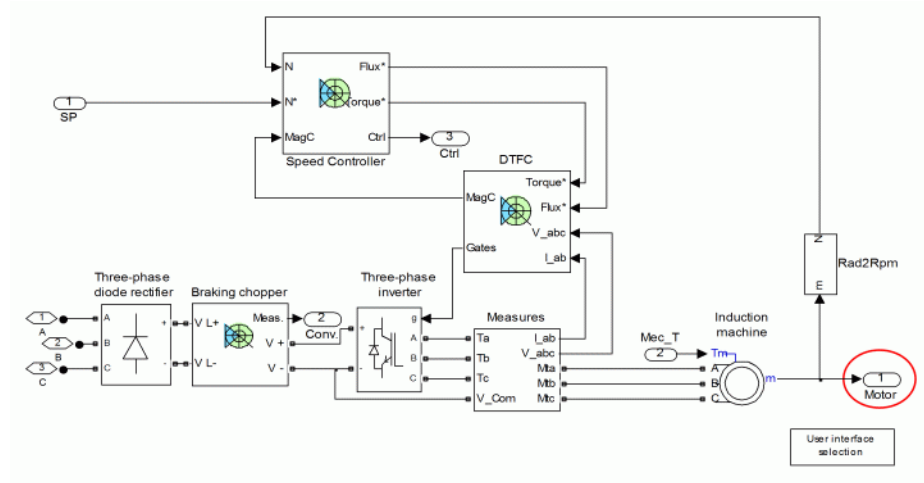

Motor Vector

In order to extract motor variable values from this vector, the Machine Measurement Demux block is needed. This block is located in the SimPowerSystems Machines library.

- 1 Open the Machines library. Copy the Measurement Demux block into ac_example. Select asynchronous machine in the **Machine Type** field and extract the rotor speed.

To obtain the load torque, the speed value must be multiplied by the constant K of Equation 4-5 (the speed is here in rad/s).

- 2 Build the subsystem of the following figure and name it Fan.

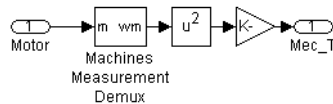

Fan Block

The constant K should be imposed so that at nominal speed, the motor develops nominal torque. This torque can be determined using Equation 4-4. Using this equation we find a nominal value of 790 N.m. Finally, Equation 4-5 gives us a K value of 0.022.

- 3 Set the constant value K to 0.022.
- 4 Connect the input and output of the Fan block to the Motor output vector and Mec_T input of the AC4 block, respectively. Your schematic should now look like the following:

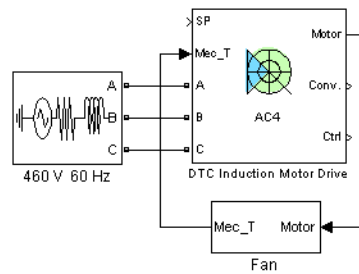

Building the Example Circuit

Defining the Set Point

We must now define the set point (SP) input of AC4. During this example, we will control the induction motor's torque and impose a series of torque set points. A series of set points can be defined with the help of the Timer block.

- 1 Open the Control Blocks section of the Extra library and copy the Timer into ac_example. Connect the block to the set point input of the AC4 model and name it Torque reference.

The Timer block generates a signal changing at specified times. During this example, we will generate the following torque series:

Torque Set Point Series

t (s)	Torque Set Point (N.m)
0	0
0.02	600
0.25	0
0.5	-600
0.75	0

2 Set the **Time** field of the Timer block to [0.02 0.25 0.5 0.75]. Set the **Amplitude** field of the timer block to [600 0 -600 0].

Visualizing Internal Signals

You must now use the AC4 model outputs to visualize interesting signals with a scope. Suppose you need to visualize the following signals:

- The motor torque value and set point
- The motor speed
- The motor flux modulus
- The motor statoric currents
- The DC bus voltage

Note that all model input-output descriptions can be found in the corresponding reference notes. All motor variable values can be read via the Motor vector. The Conv. vector contains all converter related data. The Ctrl vector includes all reference signals and other control values.

As we did for the fan block, we will use the Machine Measurement Demux block to read the motor variables. For the Conv. and Ctrl vectors, we will use Selector blocks of the Simulink Signal Routing library.

The contents of the Conv. vector can be easily determined by double-clicking the AC4 internal multimeter.

- 1 Double-click the AC4 internal multimeter (shown).

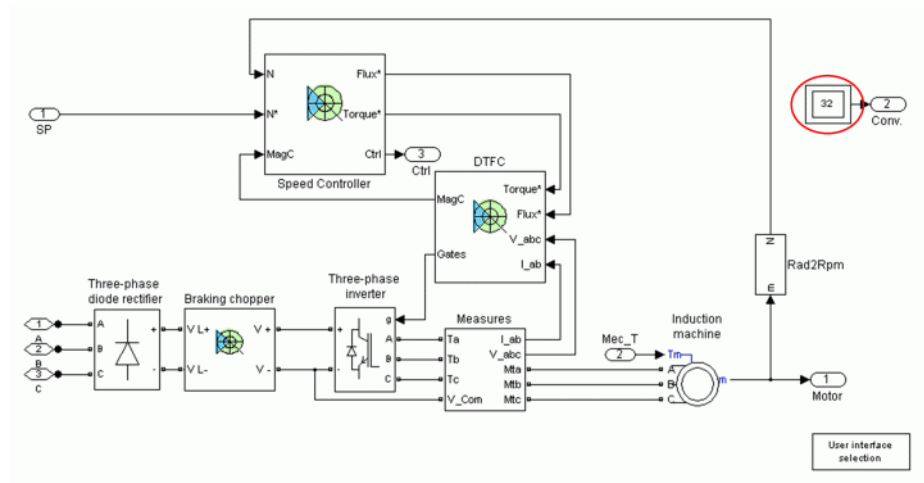

The AC4 Internal Multimeter

The Multimeter window opens (see below) displaying the contents of the multimeter. The DC bus voltage, named UDC: AC4/Rectifier_3ph, is the 10th signal of output vector Conv.

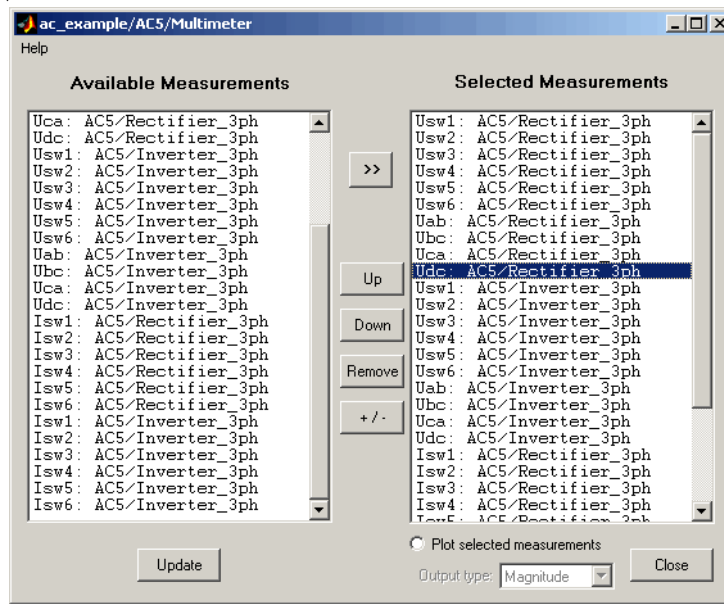

AC4 Multimeter Window

Following the input-output description of the reference notes, the torque reference signal is the third signal of output vector Ctrl.

- 2 Build the subsystem below in order to extract all the needed visualization signals. Name the subsystem Signal selector.

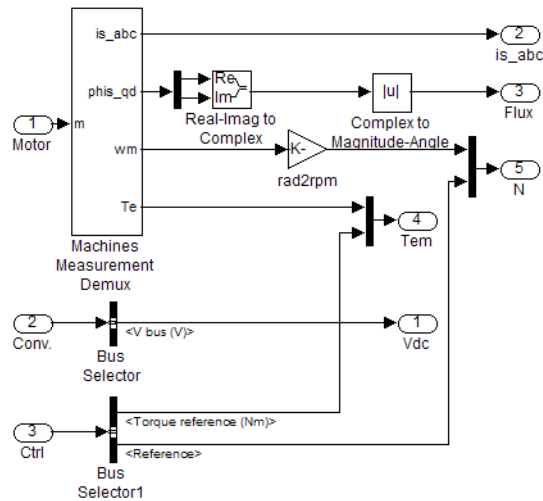

Signal Selector Subsystem

In the Machine Measurement Demux block, select the following signals: stator currents (ia, ib, ic), stator fluxes, rotor speed, and electromagnetic torque. The rad2rpm block shown above contains the constant $30/\pi$ in order to convert the rotor speed issued by the Machine Measurement Demux block from rad/s to rpm. A Real-Imag to Complex block and a Complex to Magnitude-Angle block are used to compute the magnitude of the flux vector.

- 3 Copy a scope to your model. It will be used to display the output signals of the Signal Selector block. Open the **Scope Parameters** dialog box. On the **General** tab, set the number of axes to 5, set the simulation time range to auto, and use a decimation of 25. Clear the **Limit Data Points to last** check box on the **Data history** tab. Connect the five outputs of the Signal Selector block to the inputs of the scope.

Setting the Fixed-Step Simulation Environment

All drive models of the library are discrete models. In order to simulate your system, you must now specify the correct simulation time step and set the fixed-step solver option. Recommended sample time values for DC drives, AC

drives, and mechanical models can be found in the Remarks sections of the corresponding block reference pages. The recommended sample time for the AC4 model is 1 μ s.

- 1 Open the SimPowerSystems library and copy a Powergui block into ac_example. Set the sample time to 1 μ s.

Your circuit should now look like Figure 4-5.

- 2 Open the **Simulation/Configuration Parameters** dialog box. Select the fixed-step, discrete (no continuous states) solver option. Set the stop time to 1 s and the fixed-step size to Ts.

Before simulating your circuit, you must first set the correct AC4 internal parameters.

Setting the High Power Drive Parameter Set

As explained in the DC example, many drive models of the Electric Drives library have two sets of parameters: a low power set and a high power set. By default, all models are initially loaded with the low power set. The AC4 model parameters currently loaded in ac_example are those of a 3 hp drive.

You now set the high power drive parameters, which are those of a 200 hp drive. To do this, you use the **Load** button of the user interface as specified in the DC example:

- 1 Open the user interface by double-clicking the AC4 block. The interface is shown below:

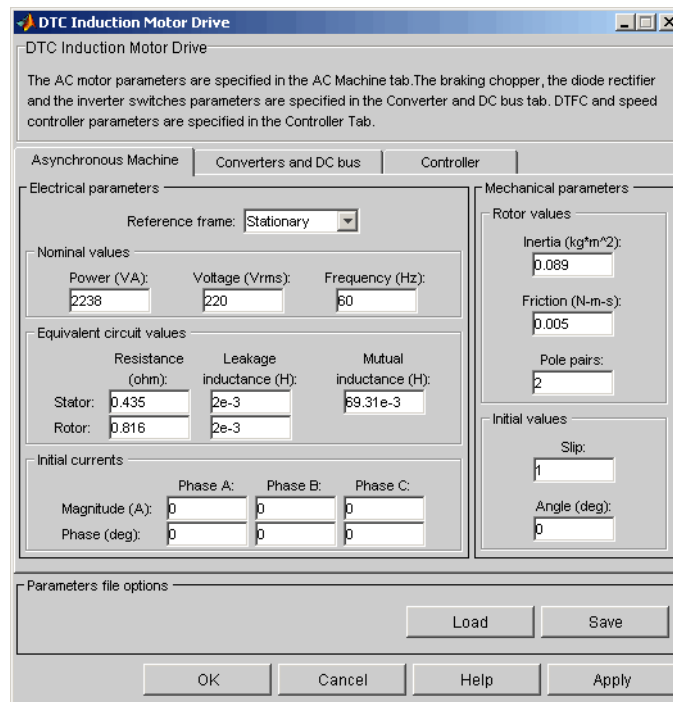

AC4 User Interface

- 2 To load the 200 hp parameters, click the **Load** button.
- 3 Select the `ac4_200hp.mat` file and click **Load**.

The 200 hp parameters are now loaded.

Setting the Motor Inertia Value

You must now set the motor inertia value. Note that the inertia values currently specified in each AC and DC model are “no-load” inertias that only represent the inertia of the rotor. If the motor is coupled to a load, these values must be increased by the load inertias. In this case, the current value of the inertia amounts to 3.1 kg.m². Assume that the combined inertia of the motor and the fan amounts to 10 kg.m². Note that the use of a flexible shaft connected between the motor and the fan would allow decoupling of the motor

and load inertias. In that case, the inertia value of the AC4 block would only be the sum of the rotor and shaft inertias.

- 1 In the **Asynchronous Machine** section of the dialog box, change the inertia value to 10 kg.m².
- 2 Click **OK** to apply the changes and close the dialog box.

Setting the Braking Chopper Resistance Value

The three-phase inverter of the DTC system is fed by a DC voltage produced by a three-phase diode rectifier. A capacitor located at the output of the rectifier reduces the DC bus voltage ripples. A braking chopper block has also been added between the rectifier block and the inverter block, in order to limit the DC bus voltage when the motor feeds back energy to the drive (shown below). This energy is “burned” through a resistance when the DC bus voltage is too high.

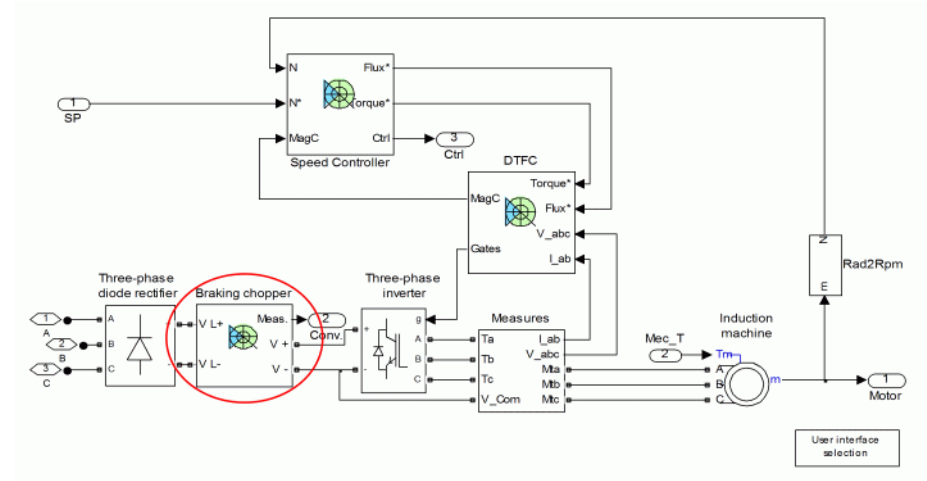

Braking Chopper

The parameters of the braking chopper are available in the **Converters and DC bus** section of the dialog box, as shown below:

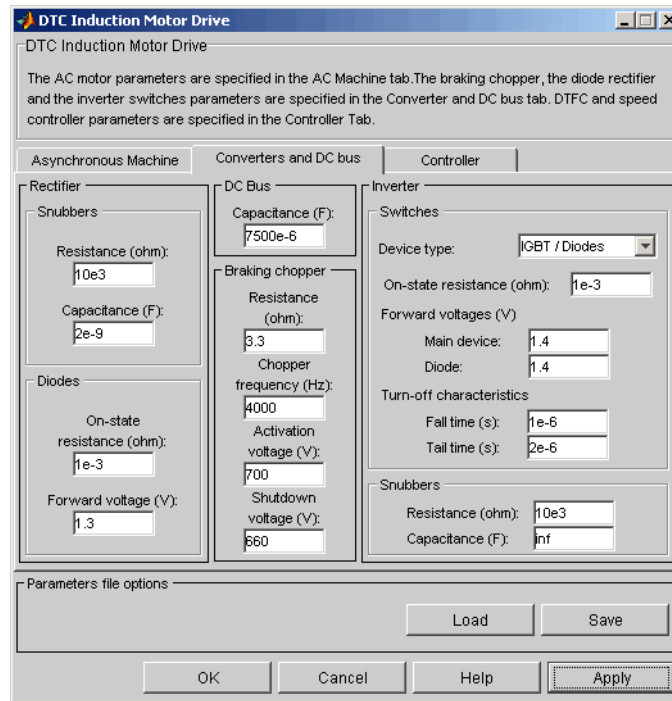

Converters and DC Bus Section of the User Interface

The braking chopper parameters are currently set to limit the DC bus voltage to about 700 V. Regarding the power P to be dissipated and the DC bus voltage limit V_{lim} , you can use the following equation to set the chopper resistance value:

$$R_{chop} = \frac{V_{lim}^2}{P}$$

A resistance of 3.3 Ω will dissipate 200 hp at 700 V.

Setting the DC Bus Initial Voltage Value

Notice that the DC bus capacitance has a large value to reduce DC voltage ripples to small values. The AC4 model does not include a DC bus capacitor preload system. If you start the simulation with too small an initial bus

voltage, too high initial currents will be drawn from the rectifier to charge the capacitor. These high current values could damage a real-life system. You must thus set an initial DC bus voltage value to avoid such currents. This initial bus voltage should be equal to the rectified peak value of the AC source. If the AC voltage source amplitude is equal to 460 V, the rectified DC bus voltage obtained with a capacitor would be about $460 \times \sqrt{2}$ V.

- 1 Double-click the Powergui block located at the top level of ac_example. Click the **Initial States Setting** button. Set the Uc_AC4/Braking chopper/Cbus value to 650 V. Click **Apply** and then **Close**.

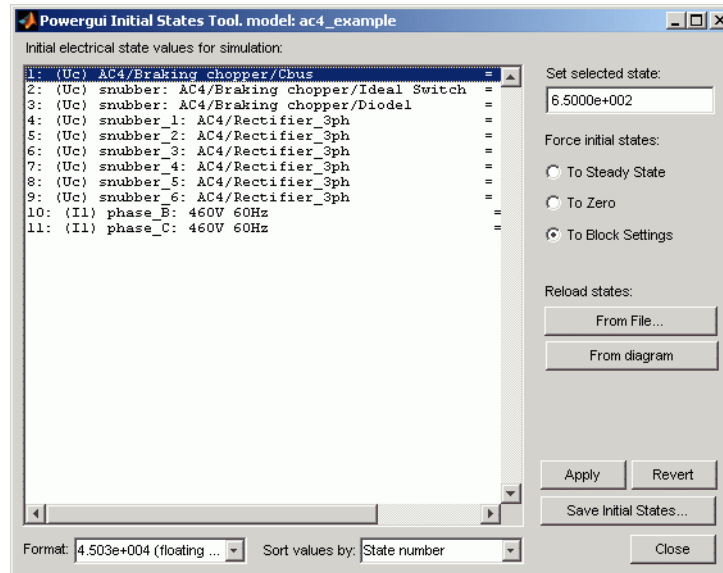
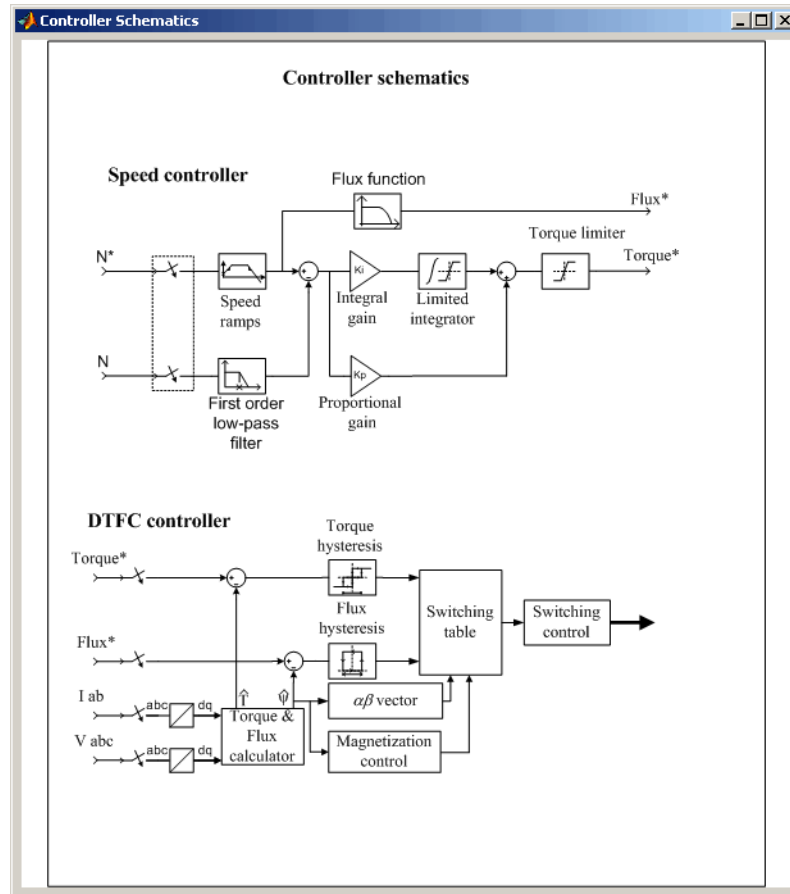

Figure 4-7: Setting the DC Bus Initial Voltage Value

Setting the AC4 Controller Parameters

The control system of AC4 has two main parts, a speed controller and a torque and flux controller (DTC). Information on these two parts can be found in the corresponding reference notes. To have a quick idea of the internal structure of the drive control system, a schematic is available inside the user interface of the model. Let's open the schematics related to the AC4 model.

- 1 Open the user interface. Click the **Controller** section and then the **Schematic** button. You should see the controller schematics shown.



Controller Schematics of the User Interface

The speed controller consists of a simple proportional-integral regulator. The parameters of this controller are the proportional and integral gains, the speed ramp values, the low-pass filter cutoff frequency, the torque reference limits, and the sampling time. In this example, we will only control the motor torque; the speed controller is not used. Refer to “Setting

the DC3 Controller Parameters and Simulation Results” on page 4-28 for more details on how to trim a PI controller.

Regarding the DTC controller, there is not much to trim. As you can see below, the parameters are the torque and flux bandwidths, the initial machine flux, the maximum switching frequency, and the DTC controller sampling time. All these parameters are already trimmed and should normally not be modified.

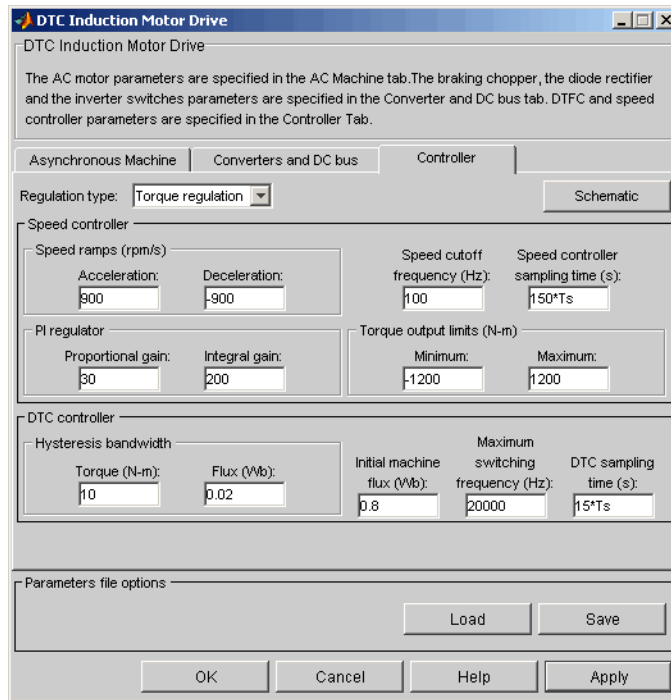

Controller Section of the User Interface

The default regulation mode is speed regulation. In order to have torque regulation, you must change the regulation mode in the **Controller** section of the user interface.

- 2** In the **Controller** section of the user interface, select Torque regulation for the **Regulation type** field. Click **OK** to apply the changes and close the dialog box.

The circuit is now ready for simulation.

Simulation Results

The simulation results are shown below.

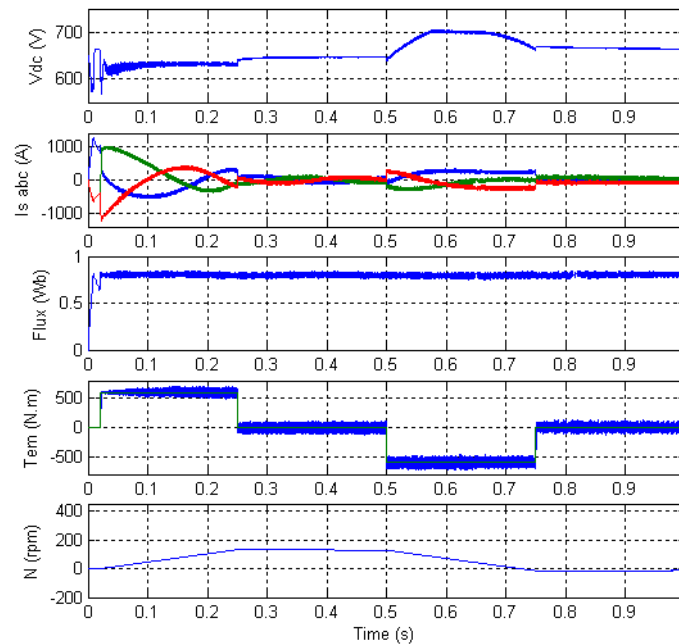

Simulation Results

Observe the motor's fast torque response to the torque set point changes. From 0.02 s to 0.25 s, the fan speed increases because of the 600 N.m acceleration torque produced by the induction motor. At t = 0.25 s, the electromagnetic torque jumps down to 0 N.m and the speed decreases because of the load torque opposed by the fan. At t = 0.5 s, the motor torque develops

a -600 N.m torque and allows braking of the fan. During braking mode, power is sent back to the DC bus and the bus voltage increases. As planned, the braking chopper limits the DC bus voltage to 700 V. At $t = 0.75$ s, the electromagnetic torque jumps back to 0 N.m and the speed settles around -10 rpm and decreases toward 0 rpm. Notice that the flux stays around 0.8 Wb throughout the simulation. The flux and torque oscillation amplitudes are slightly higher than 0.02 Wb and 10 N.m respectively as specified in the user interface. This is due to the combined effects of the $15 \mu\text{s}$ DTC controller sampling time, the hysteresis control, and the switching frequency limitation.

It is interesting to visualize the rotating flux produced by the stator. To do so, use a XY scope from the Sinks library.

- 1 Open the Sinks library.
- 2 Copy an XY scope inside the Signal selector block of ac_example.
- 3 Connect the scope as shown.
- 4 Run a new simulation.

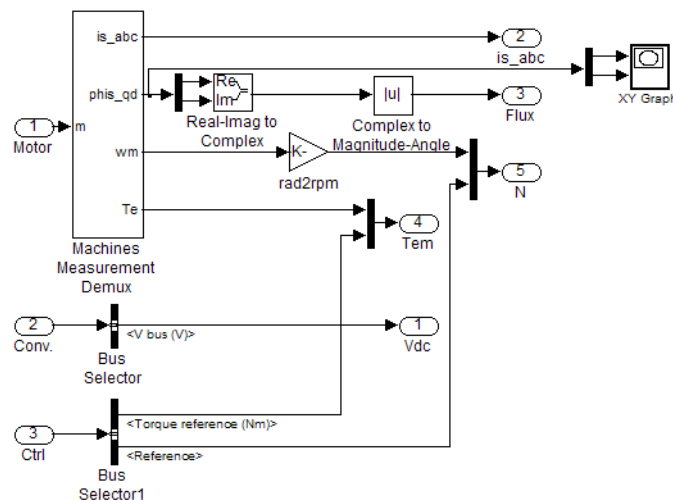

Adding a XY Graph to Visualize the Rotating Statoric Flux

The following figure shows the simulation results of the XY scope. The rotating field is clearly visible. Its modulus is about 0.8 Wb and its bandwidth is slightly bigger than 0.2 Wb.

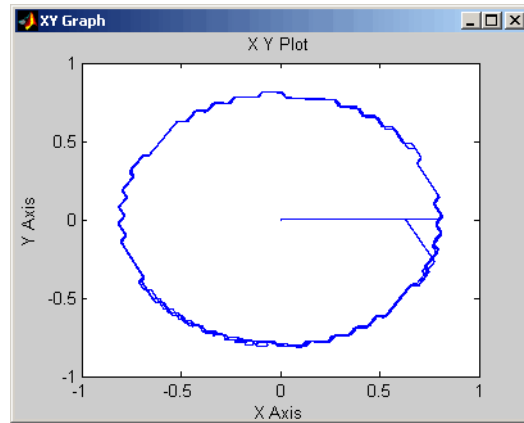

Rotating Statoric Flux

Mechanical Models

This section contains descriptions of two mechanical models:

- “Mechanical Shaft Block” on page 4-68
- “Speed Reducer Block” on page 4-69

Mechanical Shaft Block

The Mechanical Shaft block is used to simulate a shaft interconnecting mechanically a motor drive block to a mechanical load block. Hence the Mechanical Shaft block allows decoupling of the mechanical parameters of the load from the ones of the motor. The mechanical shaft is represented by its stiffness coefficient K_{sh} and damping coefficient D_{sh} . The shaft transmitted torque T_{sh} is computed with

$$T_{sh} = K_{sh} \int (\omega_m - \omega_l) dt + D_{sh} (\omega_m - \omega_l)$$

where ω_m and ω_l are the speeds of the motor and the load, respectively.

The following figure shows the interconnections between the Motor Drive block, the Mechanical Shaft block, and the Mechanical Load block. The Mechanical Shaft block has two inputs, the load and motor speeds, and one output, the shaft transmitted torque. Note that the transmitted torque is applied at the load torque input of the motor. The transmitted torque is also applied at the input of the Mechanical Load block, which can be modeled by

$$T_{sh} = J_l \frac{d\omega_l}{dt} + B_l \omega_l$$

where J_l and B_l are the inertia coefficient and the viscous friction coefficient, respectively.

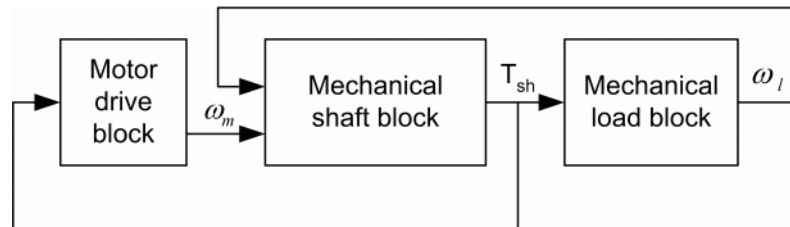

Interconnection Diagram of the Transmission Shaft

Speed Reducer Block

In many applications, the mechanical load requires high torque at low speed rather than low torque at high speed. This can be obtained by interconnecting the motor to the mechanical load by a speed reducer. The Speed Reducer block of the Electric Drives library is composed of a high-speed shaft and a low-speed shaft connected by a speed reduction device, as shown in the following figure. The speed reducer block has seven parameters: the stiffness and damping coefficients of the high-speed and the low-speed shafts, the reduction ratio, and the speed reduction device inertia and efficiency. The two inputs of the speed reducer block are the motor speed (high speed) and the load speed (low speed) while the outputs are the high-speed shaft torque T_h and the low-speed shaft torque T_l . The high-speed shaft torque must be applied to the load torque input of the motor. The low-speed shaft torque must be applied directly to the mechanical load block.

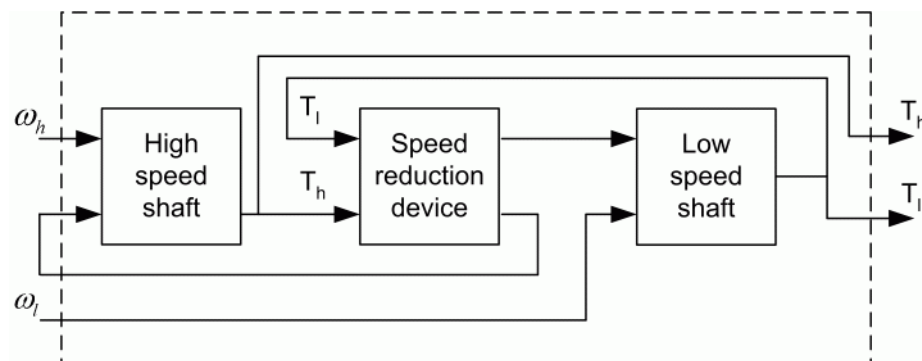

Interconnection Diagram of the Three Internal Blocks of the Speed Reducer Block

Mechanical Coupling of Two Motor Drives

In order to test a motor drive under various load conditions, you must provide a variable and bidirectional load at the motor shaft. Moreover, an ideal load should also allow returning the absorbed energy from the motor back to the power grid as electric energy. Such a load can be implemented using a four-quadrant motor drive such as the DC2 or DC4 models. Either of these two motor drives can be conveniently coupled to the motor drive model being tested by the use of the mechanical shaft model.

Therefore this case study will consist of coupling the AC4 motor drive model to the DC2 motor drive. The AC4 motor drive is a DTC three-phase induction motor-based drive. The DC2 motor drive is a single-phase dual-converter DC motor drive. In such a system, one drive is speed regulated while the other is torque regulated, but each drive can operate either as a motor or as a generator, as will be seen later. The DC2 motor drive is rated 3 hp, 240 V, 1800 rpm, and the AC4 motor drive is rated 3 hp, 380 V, 60 Hz, 4 poles.

System Description

The complete system consisting of two motor drives mechanically coupled together is shown in Figure 4-8. The mechanical shaft model is contained in the third block of the diagram. If you open this block, you will see, as in Figure 4-9, that the AC4 and DC2 motor speed signals are connected respectively to the Nm and Nl inputs of the mechanical shaft model. The output Tl of the mechanical shaft model represents the mechanical torque transmitted from the AC4 motor to the DC2 generator. Therefore, this output is connected directly to the mechanical torque input of AC4, and is also sign inverted and then connected to the mechanical torque input of DC2, as can be seen in Figure 4-8.

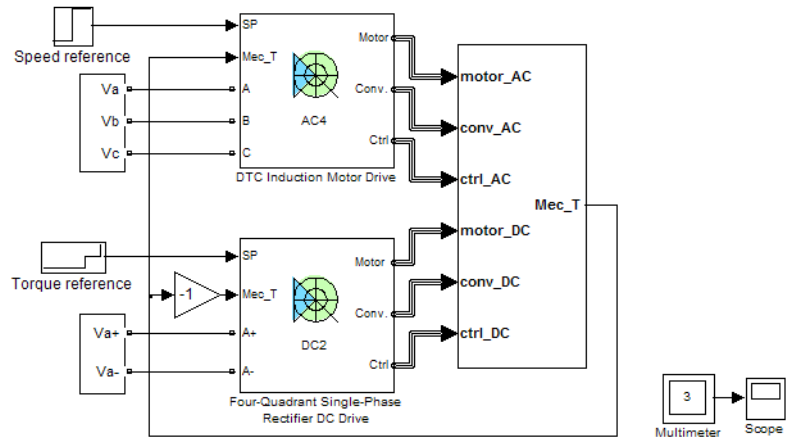

Discrete,
Ts = 1e-006 s.

Case study : Mechanical Coupling of Two Motor Drives

Louis-A. Dessaint , H. Fortin-Blanchette, C. Semaille (Ecole de technologie superieure, Montreal)

Please refer to the SimPowerSystems Electric Drives user's guide for more details on this case study.

Figure 4-8: SPS Diagram of the Two Interconnected Drives

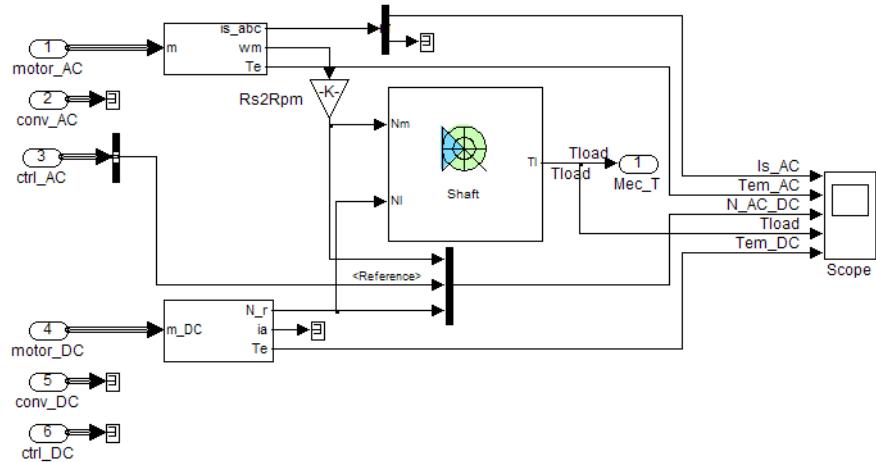

Figure 4-9: Interconnections of the Mechanical Shaft Model

Speed Regulated AC4 with Torque Regulated DC2

To begin with, the AC4 model operates as a speed regulated motor loaded by the DC2 model operating as a torque regulated generator. This setup, contained in the `cs_coupling_1.mdl` file, allows the testing of the AC4 model speed ramps and load torque disturbance responses. Note that in steady state, the signs of the AC4 electric torque and speed should be the same, confirming that AC4 operates as a motor. The DC2 electric torque and speed should be of opposite signs, confirming that DC2 operates as a generator. This is in line with the sign of the reference torque applied to the DC2 motor drive that is opposite to the speed sign.

Figure 4-10 shows the results of an AC4 motor drive startup at nearly full load followed by the application of load disturbance torques. You can see that the AC4 motor speed is exactly superposed to the reference ramp of + 400 rpm/s since the AC4 electric torque maximum limit is high enough. The AC4 motor speed reaches the demanded value of 400 rpm at $t = 1.0$ s. At that moment, the AC4 electric torque drops down to 10 N.m. Then at $t = 1.4$ s, a reference torque of 0 N.m is applied to DC2; the AC4 electric torque immediately drops down to zero in order to maintain the regulated speed. At $t = 1.9$ s, a reference torque of +10 N.m is applied to the DC2 drive, forcing AC4 to operate as a generator and DC2 as a motor (look at the speed and torque signs of the two drives). Finally, a negative reference speed ramp of -400 rpm/s is applied to AC4 at $t = 2.3$ s. Note that, again, AC4 precisely follows the demanded ramp. A new steady state is reached at $t = 2.8$ s, and the AC4 electric torque stabilizes at -10 N.m. Figure 4-10 also shows the mechanical torque transmitted by the shaft, which is similar to the AC4 electric torque but contains less ripple.

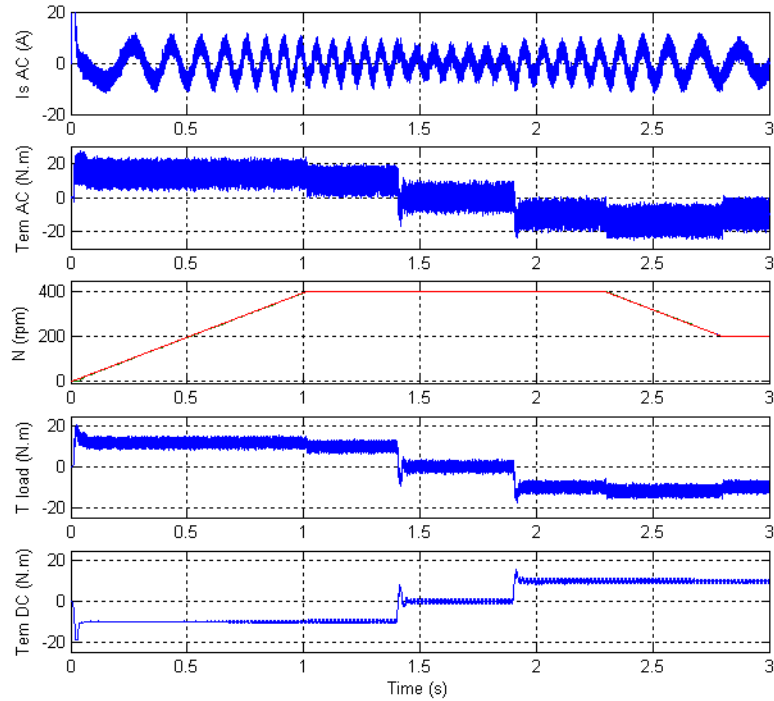

Figure 4-10: Speed Ramp and Load Disturbance Torque Responses of the AC4 Motor Drive

Torque Regulated AC4 with Speed Regulated DC2

This time, AC4 operates as a torque regulated motor loaded by the DC2 drive that is speed regulated. The complete system is shown in Figure 4-11 and is contained in the `cs_coupling_2.mdl` file. The interconnection of the mechanical shaft model with the two drives remains unchanged with respect to Figure 4-9. All the regulator gains of both drives are the same as in the previous case. The setup is tested in the same conditions as before.

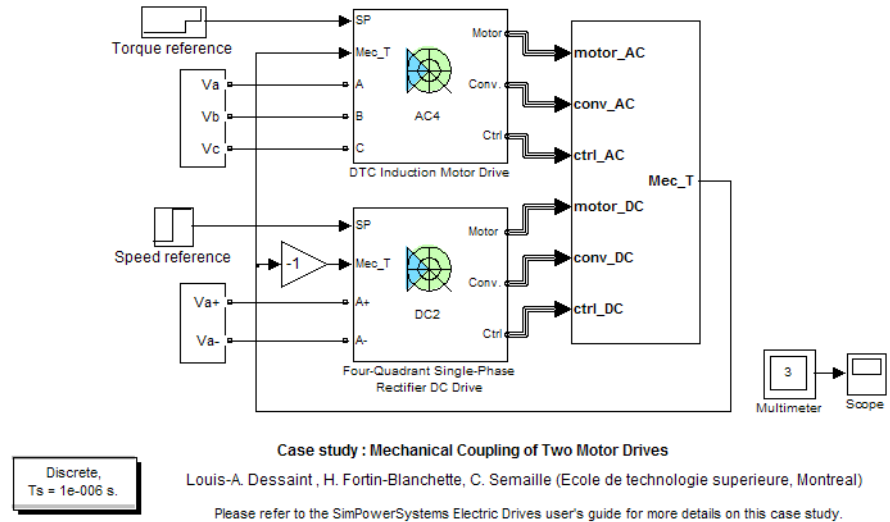

Figure 4-11: SPS Diagram of the Two Interconnected Drives

Figure 4-12 shows the results of a DC2 motor drive startup at nearly full load followed by the application of load disturbance torques. Note that the DC2 motor speed follows the reference ramp of 400 rpm/s with some overshoot and undershoot. The DC2 motor speed reaches the demanded value of 400 rpm at $t = 1.0$ s and stabilizes completely at $t = 1.2$ s. Then at $t = 1.4$ s, a reference torque of 0 N.m is applied to AC4; observe how fast the AC4 torque responds. At $t = 1.9$ s, a reference torque of +10 N.m is applied to the AC4 drive, forcing DC2 to operate as a generator and AC4 as a motor (look at the speed and torque signs of the two drives). Observe that the DC2 speed overshoots each time the load torque changes. Finally, a negative reference speed ramp of -400 rpm/s is applied to DC2 at $t = 2.3$ s. The DC2 speed follows well but presents a small overshoot and a small undershoot. A new steady state is reached at $t = 2.8$ s, and the DC2 electric torque stabilizes at -10 N.m. Figure 4-12 also shows the mechanical torque transmitted by the shaft, which is very similar to the negative of the DC2 electric torque but with more ripple.

You can see from the results shown in Figure 4-10 and Figure 4-12 that the speed ramp responses are more precise and the load torque disturbance more efficiently rejected with the AC4 drive than with the DC2 drive. This is essentially due to the fast dynamics of the AC4 electric torque. Recall that the AC4 drive consists of a direct torque controller based on hysteresis comparators and high-frequency switching, while the DC2 drive relies entirely on naturally commutated thyristor converters. However, the torque ripple magnitude of the AC4 drive is higher than for the DC2 drive.

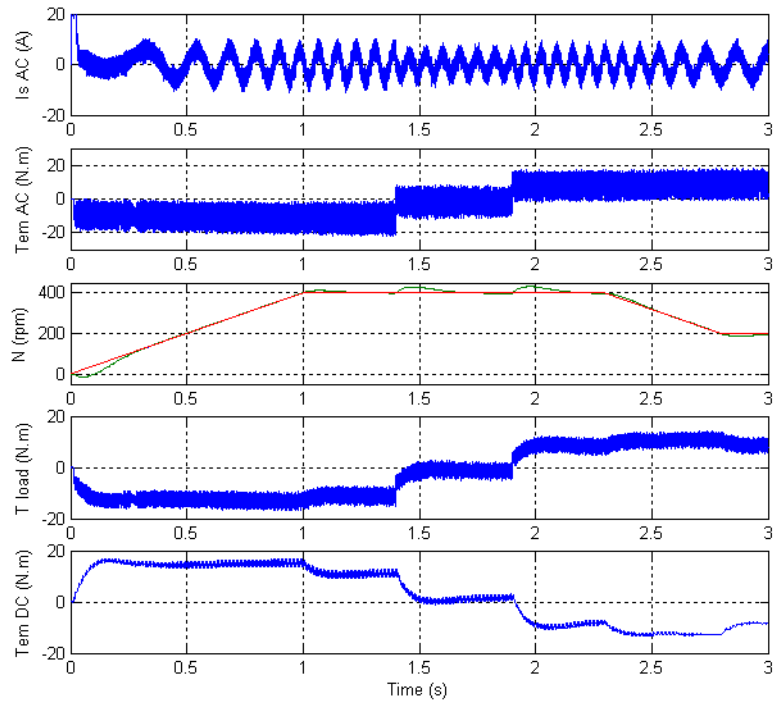

Figure 4-12: Speed Ramp and Load Disturbance Torque Responses of the DC2 Motor Drive

Winding Machine

Winding machines, also called winders, are used in the pulp and paper industry as well as in the textile, steel, and plastic industries.

An important characteristic of most winders is that the force acting on the winding material must remain constant. This is realized by controlling the winder torque proportionally to the roll variable radius. Note that it is assumed here that the material is fed to the winder at constant speed. The latter implies that the winder angular speed is forced to decrease proportionally to the roll radius. Hence the winding machine is a constant power application, because the product of the winder mechanical torque and its angular speed is constant.

Description of the Winder

Figure 4-13 shows a physical representation of a winder where W is the roll width, r_1 the core radius, r_2 the roll radius, and MT the material thickness.

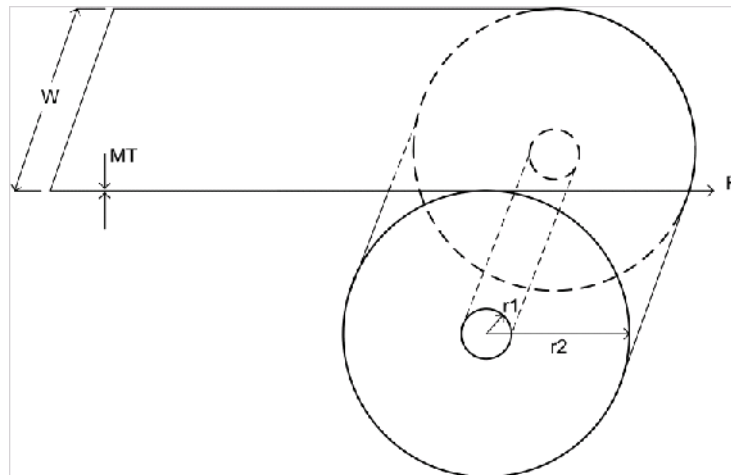
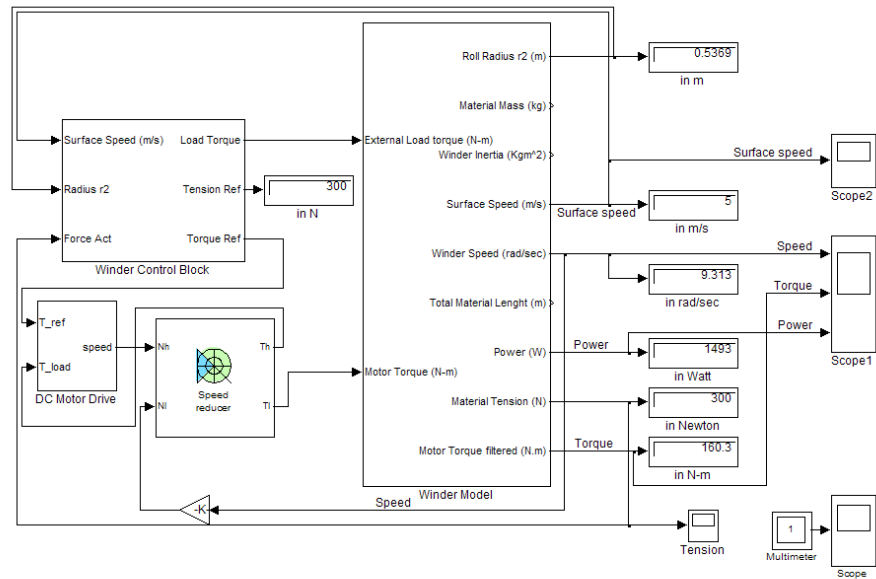

Figure 4-13: Physical Representation of a Winder

Beside the variables described above, the simulation also requires the following parameters and variables:

- MV Material mass per unit volume
- L Material length
- M Material mass
- J_r Material inertia
- J_c Winder core inertia
- B_w Winder viscous friction coefficient



Case study : Winding Machine

Louis-A. Dessaint , H. Fortin-Blanchette, C. Semaille (Ecole de technologie superieure, Montreal)

Please refer to the SimPowerSystems Electric Drives user's guide for more details on this case study.

Discrete,
Ts = 1e-006 s.

Figure 4-14: Simulink Diagram of the Complete Winding System

Figure 4-14 shows a Simulink diagram of the complete winding system. This system consists of four blocks: the Winder Control block, the DC Motor Drive block, the Speed Reducer block, and the Winder Model block.

Block Description

Winder Model Block

This block computes various winder variables using the following equations.

Surface speed

$$\text{Surface speed} = \text{winder angular speed} \times r_2$$

Material length L

$$L = \int \text{surface speed} dt$$

Roll radius r_2

$$r_2 = \sqrt{\frac{L \times MT}{\pi} + r_1^2}$$

Material mass M

$$M = MV \times \pi \times W \times (r_2^2 - r_1^2)$$

Total winder inertia J_t and material inertia J_w

$$J_t = J_w + J_c$$

where

$$J_w = \frac{1}{2} \cdot M \cdot (r_2^2 + r_1^2)$$

The winder angular speed is calculated using the following differential equation

$$T_e = J_t \cdot \frac{d\omega}{dt} + B \cdot \omega + T_l$$

where T_l is the winder load torque and T_e is the motor drive electric torque. The calculation of the tension or force F applied on the winding material is based on the same differential equation as above where the load torque is expressed as $T_l = F \times r_2$. Rearranging the equations in term of F yields

$$F = \frac{T_e - (J_t \cdot \dot{\omega}) - (B \cdot \omega)}{r_2}$$

This estimated force is fed back to the winder control block in order to be regulated.

Note that in the above two equations, the term $\omega \cdot J_t$ is omitted because it has been found to be negligible for the case considered here.

Winder Control Block

This block contains a PID controller that regulates the tension applied on the winding material. The output of this force controller is a torque reference set point for the winder motor drive. The Winder Control block shown in Figure 4-15 also contains the tension versus speed characteristic of the external process supplying the material to the winder at constant speed. This characteristic consists in a straight line of slope equal to the ratio of the reference material tension on the constant surface speed.

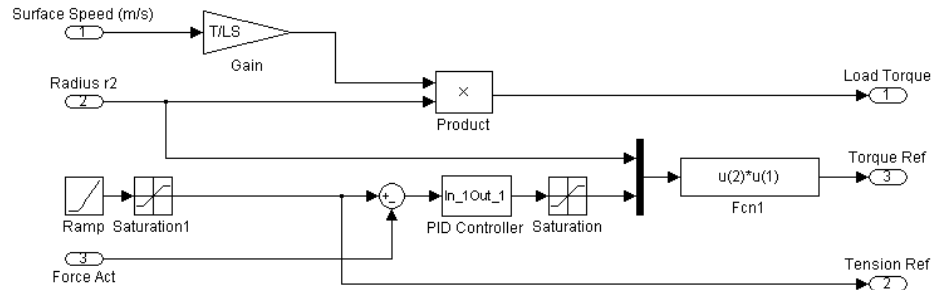

Figure 4-15: Winder Control Block

DC Motor Drive Block

This block contains a complete two-quadrant three-phase rectifier DC drive with its three-phase voltage source. The DC drive is rated 5 hp, 220 V, 50 Hz and is torque regulated.

Speed Reducer Block

The DC motor is connected to the winder by a Speed Reducer block. The speed reduction ratio is 10, allowing the winder to turn 10 times slower than the motor, while the shaft-transmitted torque is almost 10 times higher on the low-speed side. The torque required by the winder in this case study is approximately 200 N.m.

Simulation Results

The winding machine simulation model is contained in the file `cs_winder.mdl`. The simulation parameters are those of a paper winding application where the roll width is 10 m. Open the file and look at the parameters in the Simulink masks of the Winder Model block, the Winder Control block, the DC Motor Drive block, and the Speed Reducer block. In the Winder Control block, you will see that the tension set point is 300 N and the surface speed set point is 5 m/s.

The rate of change of the tension set point is limited internally to 25 N/s so that the tension set point requires 12 s to reach its final value. Note that the simulation time step of the complete model is 1 μ s in order to comply with the speed reducer, which is the block that requires the smallest simulation time step.

Start the simulation and observe how well the material tension and the surface speed ramp to their prescribed values in Figure 4-16 and Figure 4-17 respectively. Figure 4-18 shows the winder angular speed, mechanical torque, and power. Note that once the operating point is reached (300 N, 5 m/s), the angular speed decreases and the torque increases, both linearly, so that the power is approximately constant. The reason why the mechanical power is not precisely constant but decreases slightly is that the decreasing speed winder own inertia supplies a small part of the constant power required by the winder.

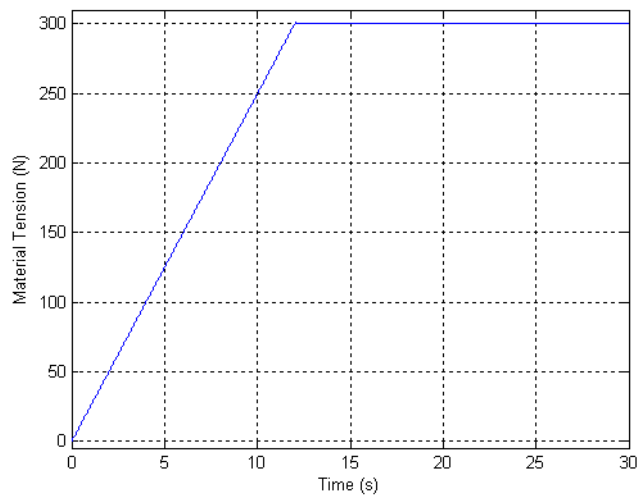

Figure 4-16: Material Tension

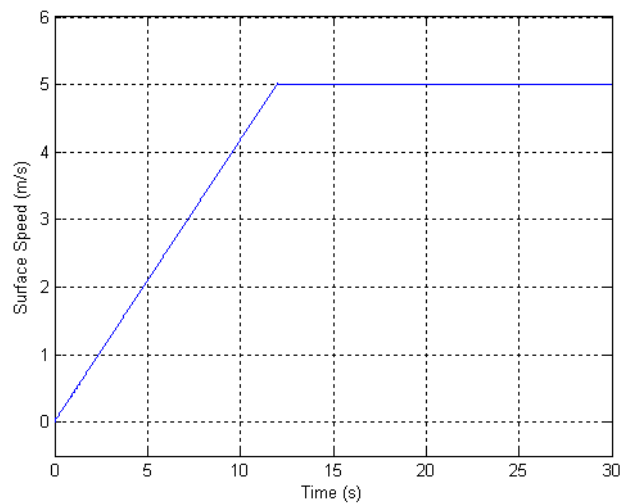

Figure 4-17: Surface Speed

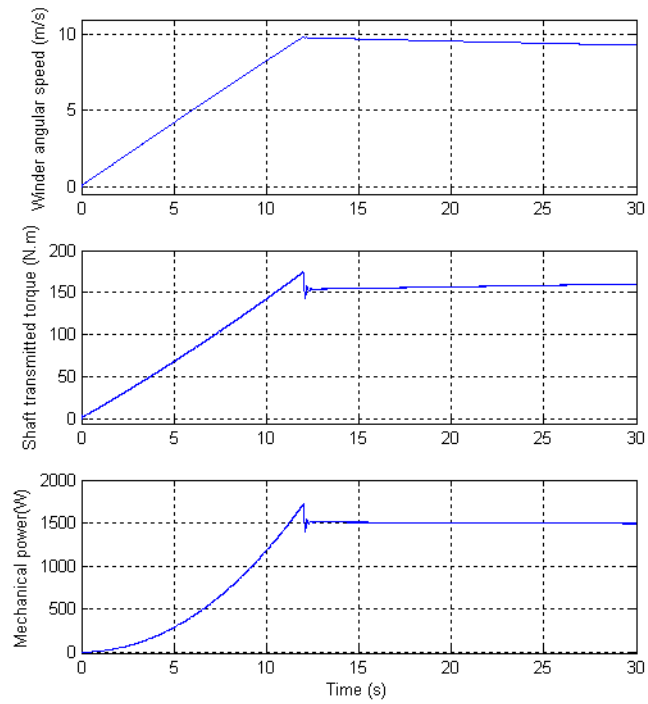

Figure 4-18: Winder Angular Speed, Mechanical Torque, and Power

Robot Axis Control Using Brushless DC Motor Drive

Robots are complex electromechanical systems where several electric drives are used to control the movement of articulated structures. The design of axis control systems for robots can be greatly facilitated by the Electric Drives library, which can model complete axes including motor drives, speed reducers, mechanical model of the arm, and controllers in the same diagram.

This case study presents the modeling and simulation of a six-degrees-of-freedom robot manipulator using Electric Drives library blocks in combination with Simulink blocks. The two main joints models are built using brushless DC motor drives that are connected to the rest of the manipulator through speed reducers (a model included in the Electric Drives library). The control system, which consists essentially of two position control loops, is built with Simulink blocks. The inner speed and torque control loops are already included in the drive model. The rest of the manipulator and its load are represented by two Simulink nonlinear models, one for each motor drive.

Detailed modeling is presented to demonstrate the versatility of the Electric Drives library. The operation of the joints using typical trajectories is simulated and results are presented.

Description of the Robot Manipulator

The robot considered in this example is a general-purpose six-degrees-of-freedom robot manipulator (GMF S-360) of parallelogram linkage type. Figure 4-19 shows the structure of the robot and its workspace. The robot has six axes. The three axes ($\theta_1, \theta_2, \theta_3$) shown in the figure are for arm positioning and the others (α, β, γ) are for orientation of the end effector. In the horizontal plane, the robot can cover a 300 degree arc ($\theta_1 = -150^\circ$ to $\theta_1 = 150^\circ$).

The robot's axes are driven by brushless DC motors that are modeled by permanent-magnet synchronous motors fed by PWM inverters (AC6 drive model). Speed reducers of belt type and gearbox are used to transmit torque from the motors to the joints.

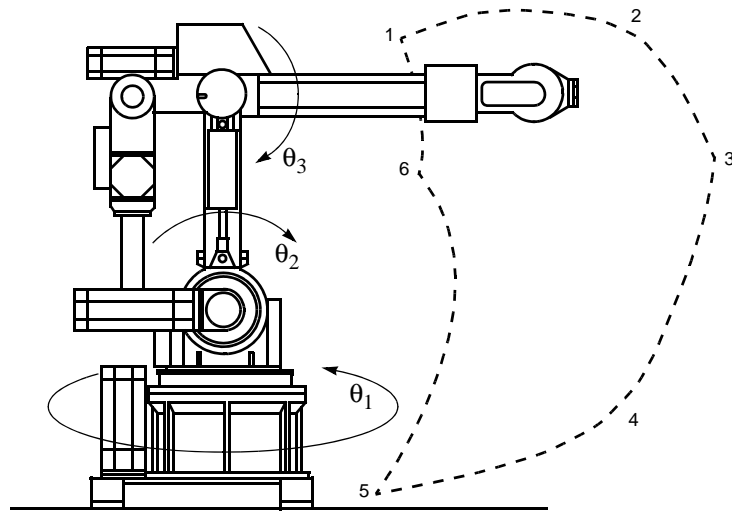

Figure 4-19: Six-Degrees-of-Freedom Robot Manipulator

Position Control Systems for Joints 1 and 2

We will consider in particular the two first joints, which drive the entire robot and its load. The first axis uses a 2 kW brushless DC motor and a 1:130 speed reducer. The second axis uses a 1 kW brushless DC motor and a 1:100 speed reducer. Figure 4-20 shows a simplified diagram of the position control system for one robot link.

The control system consists of three control loops connected in a cascade configuration: an outer position loop includes an inner speed control loop and an innermost current control loop. The PM synchronous motor is fed by a three-phase PWM inverter operating in current-controlled mode. Field-orientation scheme is used to decouple the variables so that flux and torque can be separately controlled by stator direct-axis current i_{ds} and quadrature-axis current i_{qs} , respectively. The quadrature-axis current reference i_{qs}^* (which represents the torque command) is provided by the speed control loop. The direct-axis current reference i_{ds}^* is kept equal to 0.

A speed/position sensor is used to provide the information required by the speed and position control loops. The rotor position is also required for coordinates conversion (dq to abc).

Each motor drives the rest of the robot structure, including the other links and the load, through a speed reducer.

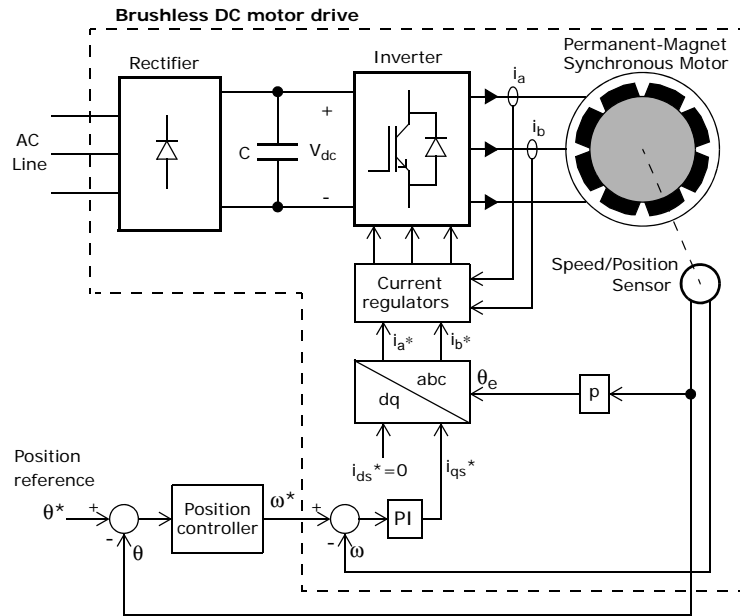

Figure 4-20: Brushless DC Motor Drive for Position Control of Robot Joint

Modeling the Robot Position Control Systems

The entire drive system for the robot's two first joints, including motor drives, speed reducers, equivalent loads, and controllers can be modeled in the same diagram using blocks from the Electric Drives library and Simulink libraries, as shown in Figure 4-21.

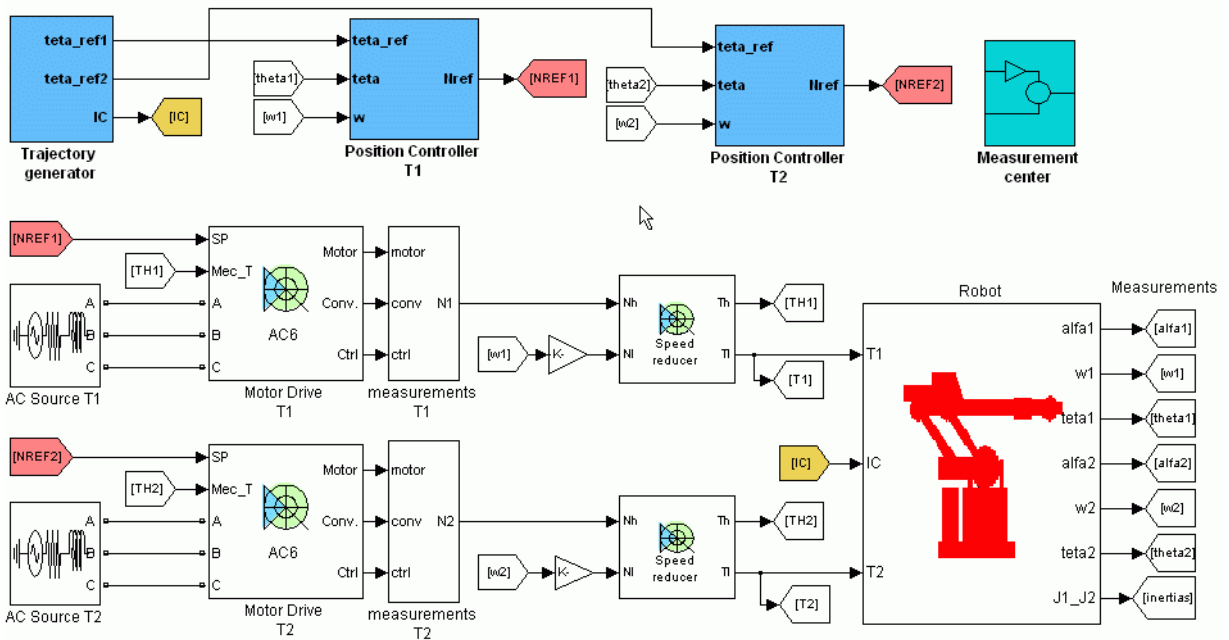

Figure 4-21: Simulink Diagram Representing the Robot's Main Axes Drive Systems

The brushless DC motor drives are represented by two AC6 (PM Synchronous Motor Drive) blocks from the Electric Drives library. This block models a complete brushless DC motor drive including a permanent-magnet synchronous motor (PMSM), an IGBT inverter, speed controller, and current controller. The AC6 inputs are the speed commands and the outputs are the motor speed, which are fed to the inputs of the speed reducers.

The speed reducers are modeled by two Speed Reducer blocks from the Electric Drives library. The inputs for these blocks are the motors' speeds, and the outputs are the torques from the low-speed sides, which are applied to the robot structure model. The speed reducers are characterized by their ratio and inertia and the stiffness and damping of input and output shafts.

The speed reducers' output shafts are connected to the T_1 and T_2 inputs of a Robot block that represents the rest of the robot structure. This block calculates the effective torque reflected to each joint. For each joint (numbered i), we can consider globally the other links effects as a single load reflecting to the joint a torque that is composed of three terms

$$T_L = J_i \frac{d^2 \theta_i}{dt^2} + C_i \frac{d\theta_i}{dt} + G_i \theta_i \quad (4-6)$$

where θ_i is joint angular position, J_i is inertia, C_i is centrifugal and Coriolis coefficient, and G_i is gravitational coefficient.

The Robot model is built with Simulink blocks.

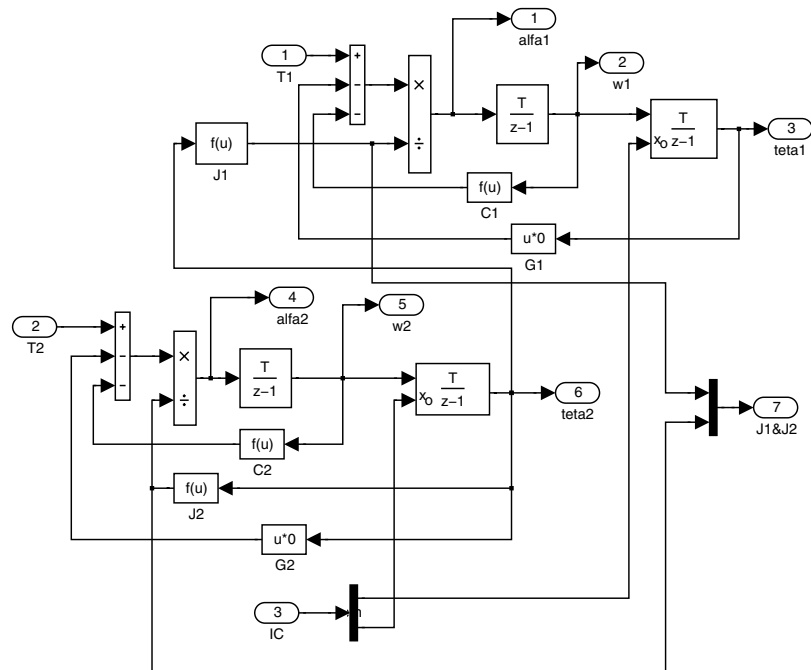

In this diagram, the parameters J_1 , C_1 , G_1 , J_2 , C_2 , and G_2 are functions of joint positions. Implement them by using polynomials or lookup tables.

The joint positions θ_1 and θ_2 are controlled by outer control loops that force θ_1 and θ_2 to follow the references imposed by the trajectories of the manipulator. Various algorithms can be used for these control loops. The most popular ones are proportional-derivative, computed torque, and adaptive. In this example, proportional-derivative controllers are implemented for both axes.

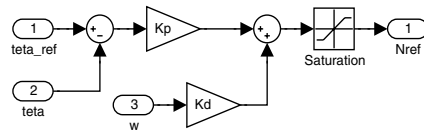

Cubic polynomial test trajectories for robot motion are generated by the Trajectory Generator block.

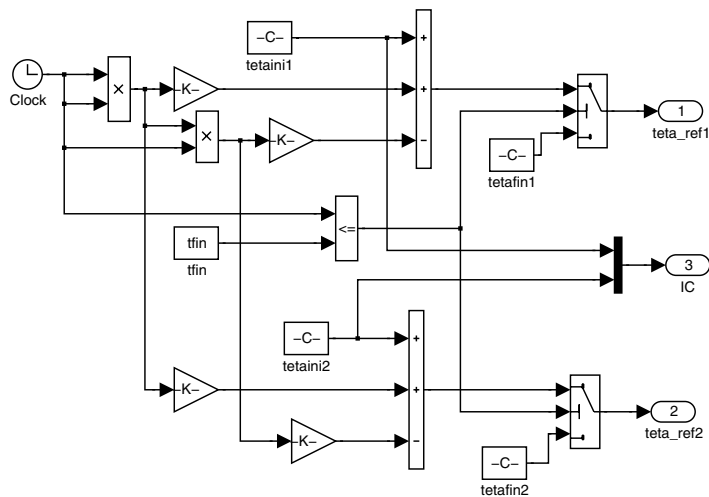

The test trajectories consist of a movement from position 6 to position 3 in the workspace (θ_2 varying from $-\pi/4$ to $\pi/4$) while rotating around axis 1 from one position to another (θ_1 varying from $-\pi/6$ to $\pi/6$). The parameters to be specified for this block are initial position [θ_{1ini} , θ_{2ini}], final position [θ_{1fin} , θ_{2fin}], and move time. The following figure shows the changes of robot structure during the programmed movement.

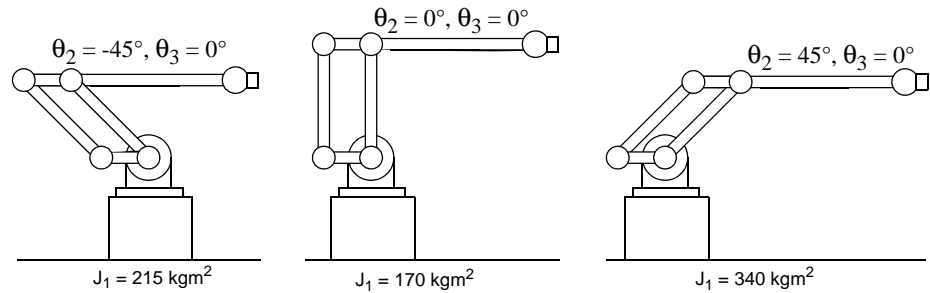

The variation of inertia due to structure changes is reflected to axis 1 as an inertia varying as a function of θ_2 (from 215 kgm^2 to 340 kgm^2 passing by a minimum of 170 kgm^2). The inertia reflected to axis 2 is a constant ($J_2 = 50 \text{ kgm}^2$). These inertia variations are represented by nonlinear functions implemented in the Robot block.

Tracking Performance of the Motor Drives

The test trajectories described above constitute one of the most demanding trajectories for the motor drive of the first and second joints. They are used here to evaluate the tracking performance of the two electric drive systems.

In the simulation, the manipulator is programmed to rotate from -30° to 30° during 1.5 seconds, and at the same time the arm is moved from the back position ($\theta_2 = -45^\circ$) to the most advanced position ($\theta_2 = 45^\circ$). The simulation is run using a time step of $1 \mu\text{s}$.

The responses of the manipulator and the motor drives 1 and 2 are displayed on three scopes connected to the output variables of the AC6 and Robot blocks. The results are shown in Figure 4-22, Figure 4-23, and Figure 4-24.

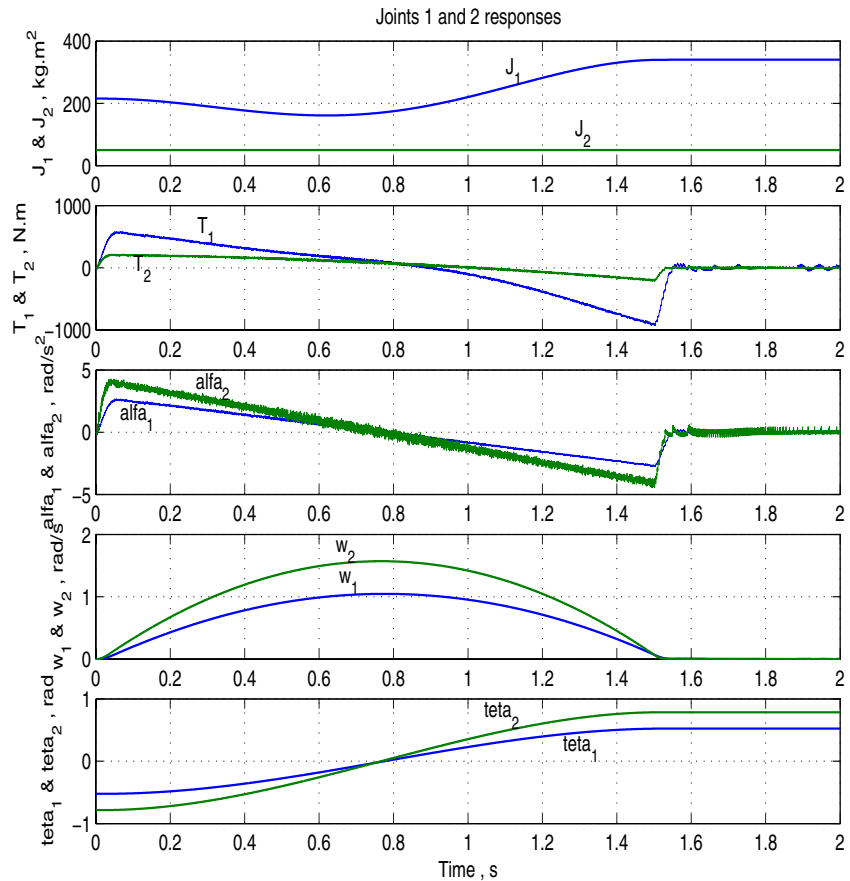

Figure 4-22: Responses of the Manipulator's Joints 1 and 2 During a Test Trajectory

During the movement, the joint positions θ_1 and θ_2 follow the imposed cubic trajectories with low tracking error. The shapes of the speeds and accelerations are in very good agreement with theoretical predictions. The speed variations are second-degree curves and the accelerations are almost linear curves.

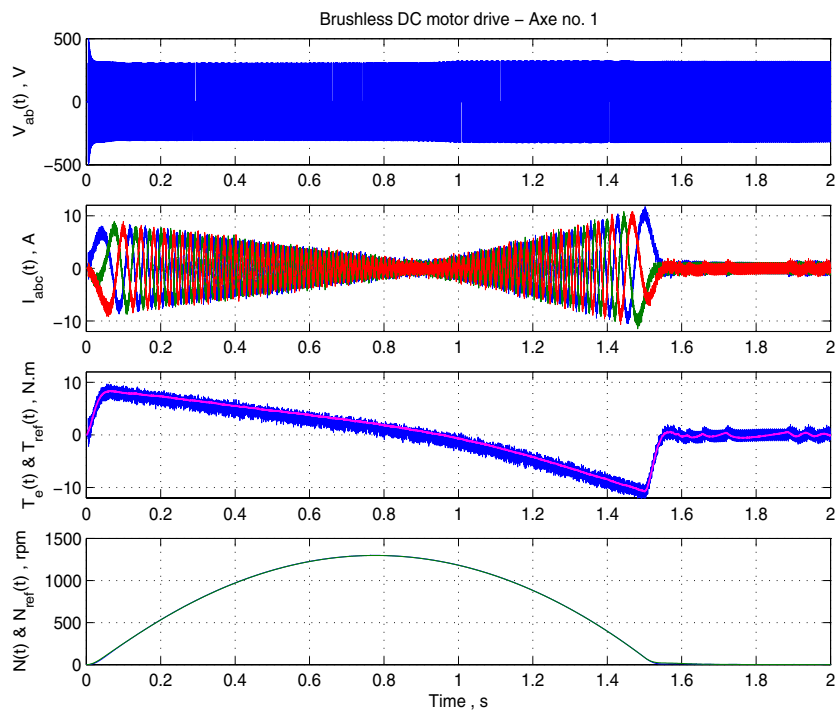

Figure 4-23: Responses of the Brushless DC Motor Drive of Axis No. 1 During Test Trajectory

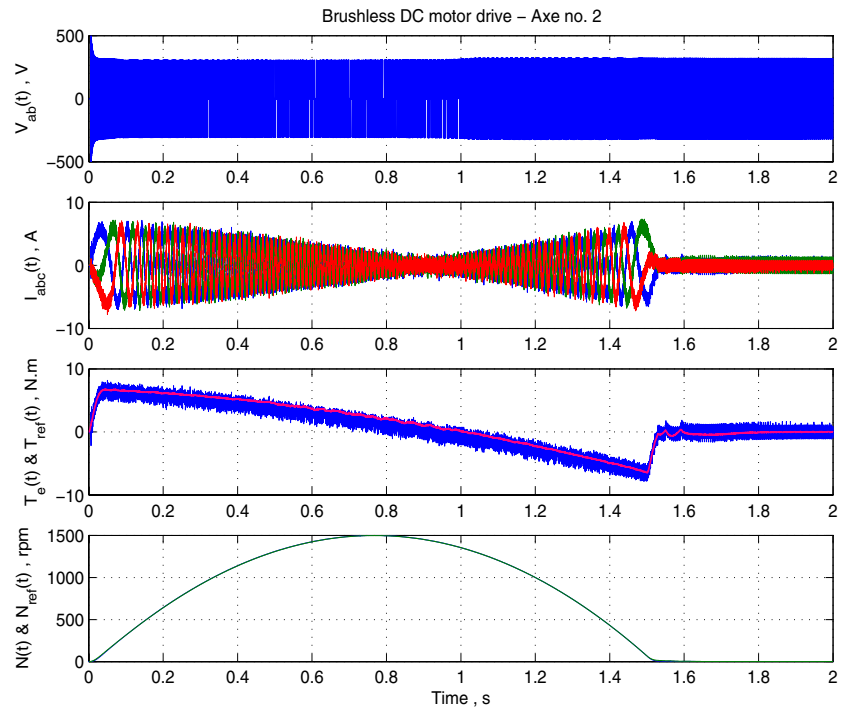

Figure 4-24: Responses of the Brushless DC Motor Drive of Axis No. 2 During Test Trajectory

The brushless DC motor drives behave very well during the test trajectories. The DC bus voltages are maintained at relatively constant levels during the deceleration of the motors. The developed torques are proportional to the motor currents' amplitudes. This demonstrates the good operation of the field-oriented control algorithms. As can be noted on the waveforms, the motor speeds track their reference profiles with very small errors.

References

- [1] Miller, T. J. E., *Brushless Permanent-Magnet and Reluctance Motor Drives*, Clarendon Press, Oxford, 1989.

[2] Spong, M. W., and Vidyasagar, M., *Robot Dynamics and Control*, John Wiley & Sons, New York, 1989.

Building Your Own Drive

Although the Electric Drives library contains models of the 13 most widely used in the industry, you might have some specific requirements leading you to build your own motor drive model. The following shows you how to build a motor drive model using Simulink and SimPowerSystems blocks. You will build the field-oriented-control motor drive, very similar to the AC3 model of the electric drive library. The figure shows the block diagram of the drive.

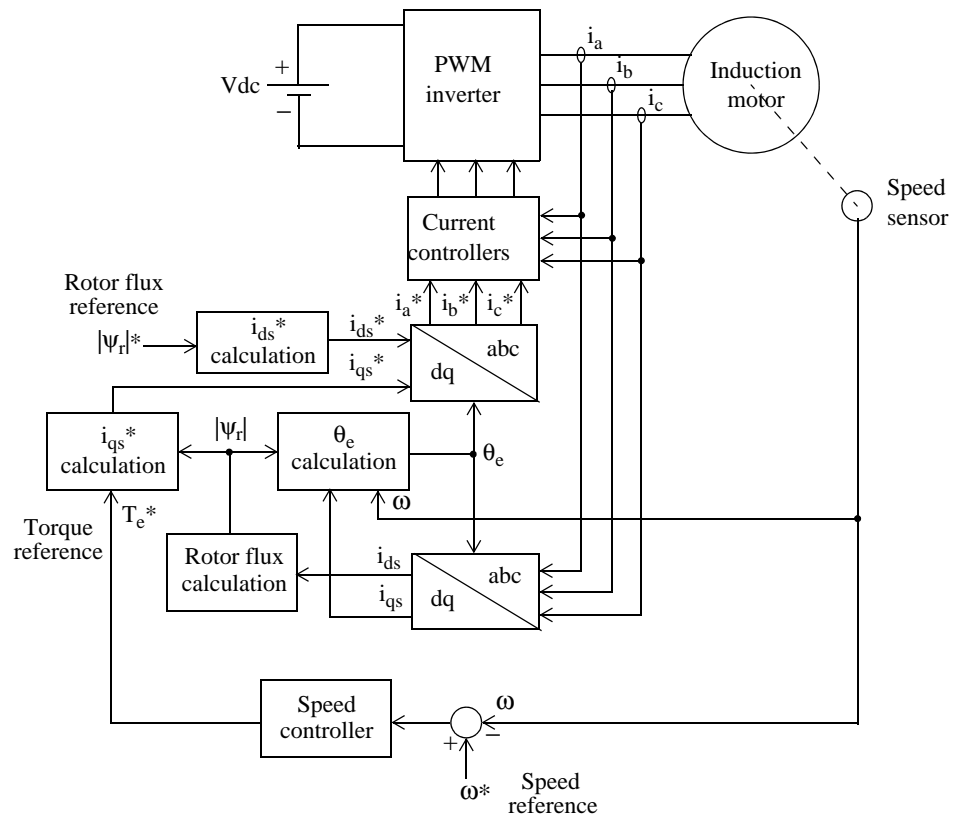

Field-Oriented Variable-Frequency Induction Motor Drive

Description of the Drive

The induction motor is fed by a current-controlled PWM inverter, which operates as a three-phase sinusoidal current source. The motor speed ω is compared to the reference ω^* and the error is processed by the speed controller to produce a torque command T_e^* .

As shown below, the rotor flux and torque can be separately controlled by the stator direct-axis current i_{ds} and quadrature-axis current i_{qs} , respectively.

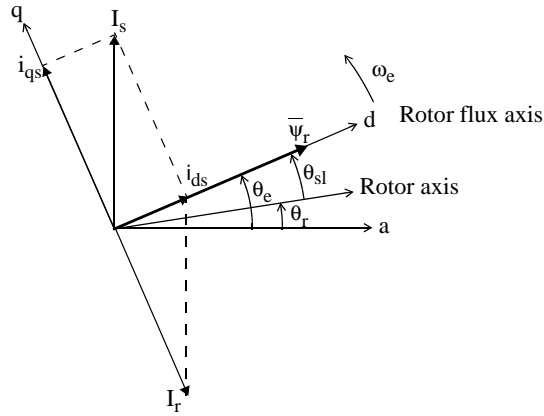

Field-Oriented Control Principle

The mathematical principles of this AC drive have been discussed in “Getting Started with Electric Drives Library” on page 4-4. Here, we will only rewrite the basic equations. The stator quadrature-axis current reference i_{qs}^* is calculated from torque reference T_e^* as

$$i_{qs}^* = \frac{2}{3} \cdot \frac{2}{p} \cdot \frac{L_r}{L_m} \cdot \frac{T_e^*}{|\psi_r|_{est}}$$

where L_r is the rotor inductance, L_m is the mutual inductance, and $|\psi_r|_{est}$ is the estimated rotor flux linkage given by

$$|\psi_r|_{est} = \frac{L_m i_{ds}}{1 + \tau_r s}$$

where $\tau_r = L_r / R_r$ is the rotor time constant.

The stator direct-axis current reference i_{ds}^* is obtained from rotor flux reference input $|\Psi_r|^*$.

$$i_{ds}^* = \frac{|\Psi_r|^*}{L_m}$$

The rotor flux position θ_e required for coordinates transformation is generated from the rotor speed ω_m and slip frequency ω_{sl} .

$$\theta_e = \int (\omega_m + \omega_{sl}) dt$$

The slip frequency is calculated from the stator reference current i_{qs}^* and the motor parameters.

$$\omega_{sl} = \frac{L_m}{|\Psi_r|_{est}} \cdot \frac{R_r}{L_r} \cdot i_{qs}^*$$

The i_{qs}^* and i_{ds}^* current references are converted into phase current references i_a^* , i_b^* , i_c^* for the current regulators. The regulators process the measured and reference currents to produce the inverter gating signals.

The role of the speed controller is to keep the motor speed equal to the speed reference input in steady state and to provide a good dynamic during transients. The controller can be a proportional-integral type.

Modeling the Induction Motor Drive

Open the `power_acdrive` model and save it as `case3.mdl` in your working directory so that you can make further modifications without altering the original file.

The next figure shows the `power_acdrive` model in which blocks from SimPowerSystems and Simulink are used to model the induction motor drive.

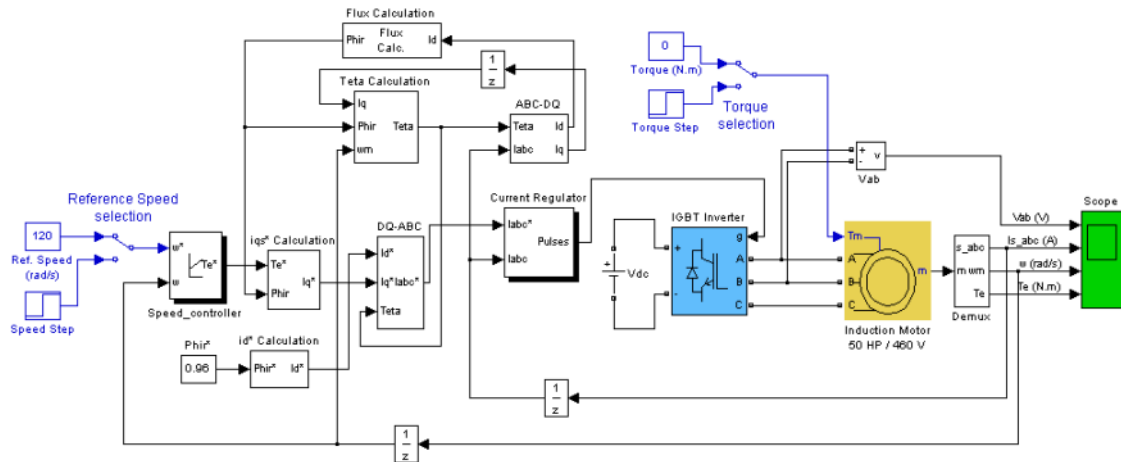

Figure 4-25: Variable-Speed Field-Oriented Induction Motor Drive (power_acdrive)

The induction motor is modeled by an Asynchronous Machine block. The motor used in this case study is a 50 HP, 460 V, four-pole, 60 Hz motor having the following parameters:

Rs	0.087 Ω
Lls	0.8 mH
Lm	34.7 mH
Rr	0.228 Ω
Llr	0.8 mH

The reference speed and the load torque applied to the motor shaft can be both selected by a Manual Switch block in order to use either a constant value or a step function. Initially the reference speed is set a constant value of 120 rad/s and the load torque is also maintained constant at 0 N.m

The current-controlled PWM inverter circuit is shown in Figure 4-25. The IGBT inverter is modeled by a Universal Bridge block in which the **Power Electronic device** and **Port configuration** options are selected as IGBT/Diode and ABC as output terminals respectively. The DC link input voltage is represented by a 780 V DC voltage source.

The current regulator, which consists of three hysteresis controllers, is built with Simulink blocks. The motor currents are provided by the measurement output of the Asynchronous Machine block.

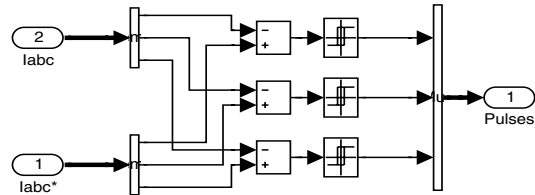

The conversions between abc and dq reference frames are executed by the abc_to_dq0 Transformation and dq0_to_abc Transformation blocks shown in Figure 4-25.

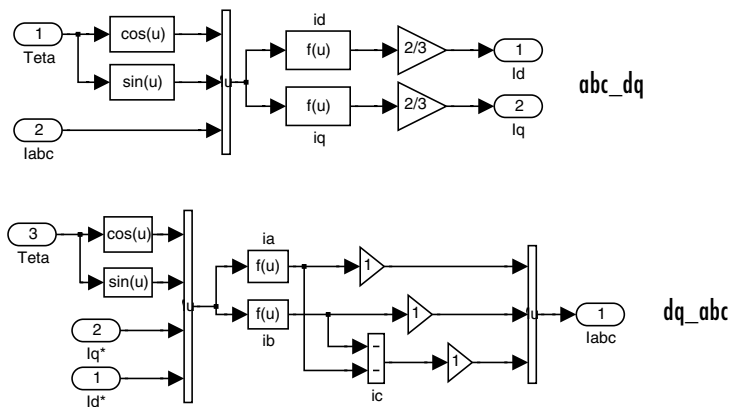

The rotor flux is calculated by the Flux_Calculation block shown in Figure 4-25.

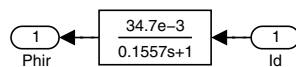

The rotor flux position (θ_e) is calculated by the Teta Calculation block of Figure 4-25.

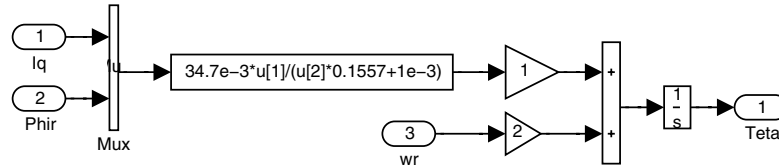

The stator quadrature-axis current reference (i_{qs}^*) is calculated by the i_{qs}^* _Calculation block shown in Figure 4-25.

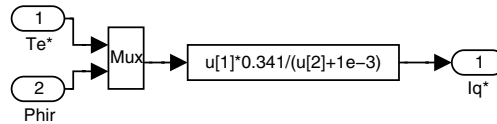

The stator direct-axis current reference (i_{ds}^*) is calculated by the i_{ds}^* _Calculation block shown in Figure 4-25.



The speed controller is of proportional-integral type and is implemented using Simulink blocks.

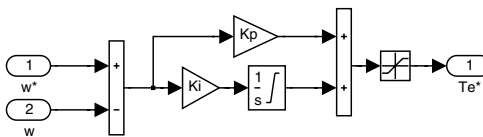

Simulating the Induction Motor Drive

In order to increase simulation speed, this model is discretized using a sample time of $2 \mu\text{s}$. The variable $T_s = 2e-6$ automatically loads into your workspace when you open this model. This sample time T_s is used both for the power circuit (T_s specified in the Powergui) and the control system.

Run the simulation by selecting **Start** from the **Simulation** menu in Simulink.

The motor voltage and current waveforms as well as the motor speed and torque are displayed on four axes of the scope connected to the variables V_{ab} , I_s , T_e , and ω .

Starting the Drive

You can start the drive by specifying $[1, 0, 0, 0, 0, 0, 0, 0]$ as the initial conditions for the Asynchronous Machine block (initial slip = 1 and no currents flowing in the three phases). The speed reference is 120 rad/s.

The motor speed, electromechanical torque, and currents observed during the starting of the induction motor drive are shown in Figure 4-26.

Note that you can save the final system state vector x_{Final} by selecting the **Workspace I/O** \rightarrow **Save to workspace** \rightarrow **Final state** check box in the **Simulation parameters** dialog. It can be used as the initial state in a subsequent simulation so that the simulation can start under steady-state conditions.

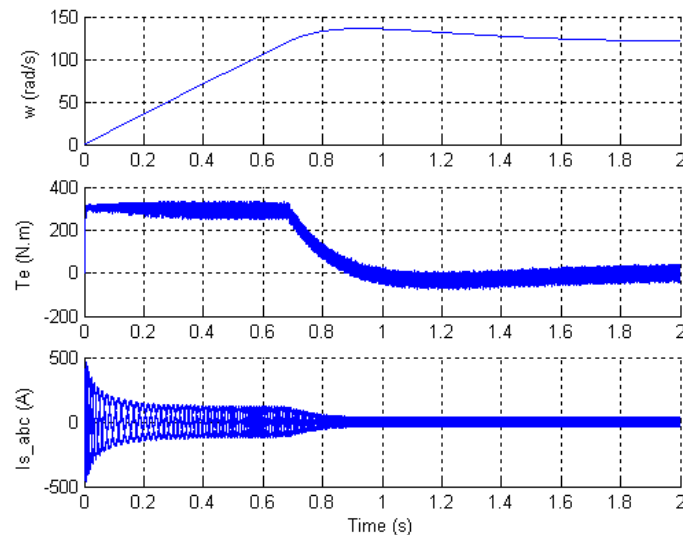

Figure 4-26: Starting the Induction Motor Drive

Steady-State Voltage and Current Waveforms

When the steady state is attained, you can stop the simulation and zoom on the scope signals.

This figure shows the motor voltage, current, and torque waveforms obtained when the motor is running at no load (torque = 0 N.m) at a speed of 120 rad/s.

The 20 A band imposed by the hysteresis current regulator is clearly seen on the three motor currents.

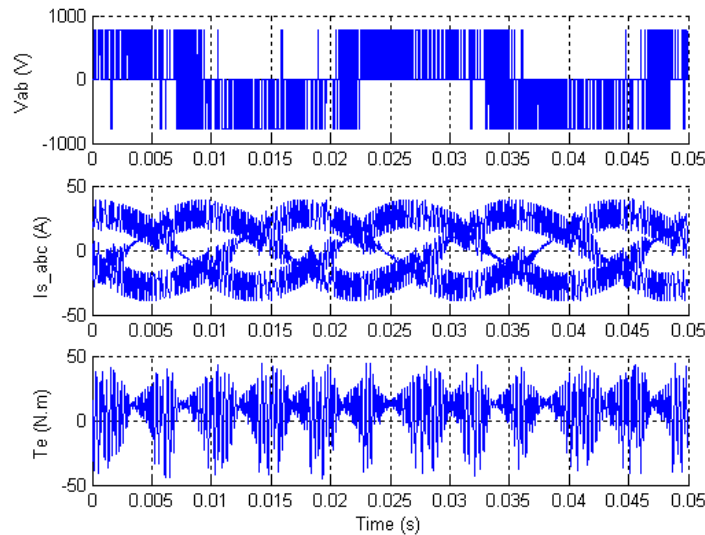

Steady-State Motor Current, Voltage, and Torque Waveforms

Speed Regulation Dynamic Performance

You can study the drive dynamic performance (speed regulation performance versus reference and load torque changes) by applying two changing operating conditions to the drive: a step change in speed reference and a step change in load torque.

Use the Reference Speed selection switch and the Torque selection switch to set speed reference steps from 120 rad/s to 160 rad/s at $t = 0.2$ s and the load torque steps from 0 N.m to 200 N.m at $t = 1.8$ s. The final state vector obtained

with the previous simulation can be used as the initial condition so that the simulation starts from steady state. Load the `power_acdrive_init.mat` file, which creates the `xInitial` variable. Select the **Workspace I/O** → **Load from workspace** → **Initial state** check box in the **Simulation parameters** dialog and restart the simulation.

The response of the induction motor drive to successive changes in speed reference and load torque is shown here.

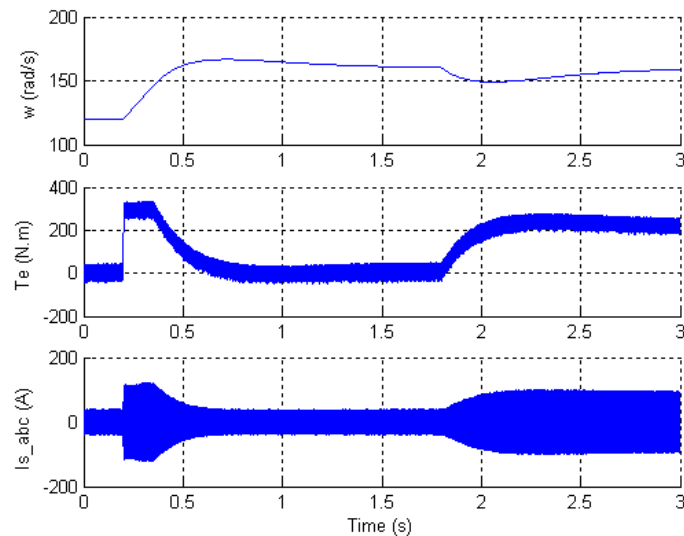

Dynamic Performance of the Induction Motor Drive

References

- [1] Leonhard, W., *Control of Electrical Drives*, Springer-Verlag, Berlin, 1996.
- [2] Murphy, J. M. D., and Turnbull, F. G., *Power Electronic Control of AC Motors*, Pergamon Press, Oxford, 1985.
- [3] Bose, B. K., *Power Electronics and AC Drives*, Prentice-Hall, Englewood Cliffs, N.J., 1986.

Transients and Power Electronics in Power Systems

These case studies provide detailed, realistic examples of how to use SimPowerSystems in typical power utility applications. All these examples use fixed-step discretized models. Case 1 shows a study of transients in an AC series-compensated transmission system. Cases 2 to 5 show examples of power-electronics based flexible AC transmission systems (FACTS) and cover two typical areas of FACTS applications:

- Cases 2 and 3 illustrate shunt reactive power compensation using two different technologies: a SVC using thyristors and a STATCOM using a square-wave GTO voltage-sourced converter.
- Cases 4 and 5 illustrate two technologies of power conversion for HVDC transmission: thyristor converters and pulse width modulation (PWM) voltage-sourced converters.

Series-Compensated Transmission System (p. 5-2)

Study of transients in AC series-compensated transmission system

Thyristor-Based Static Var Compensator (p. 5-20)

Study of a static var compensator (SVC) using three thyristor-switched capacitor banks (TSC) and one thyristor-controlled reactor bank (TCR)

GTO-Based STATCOM (p. 5-29)

Study of static synchronous compensator (STATCOM) using a GTO 48-pulse converter

Thyristor-Based HVDC Link (p. 5-39)

Study of high-voltage DC (HVDC) transmission link using 12-pulse thyristor current converters

Series-Compensated Transmission System

The example described in this section illustrates modeling of series compensation and related phenomena such as subsynchronous resonance in a transmission system.

Description of the Transmission System

The single-line diagram shown here represents a three-phase, 60 Hz, 735 kV power system transmitting power from a power plant consisting of six 350 MVA generators to an equivalent system through a 600 km transmission line. The transmission line is split into two 300 km lines connected between buses B1, B2, and B3.

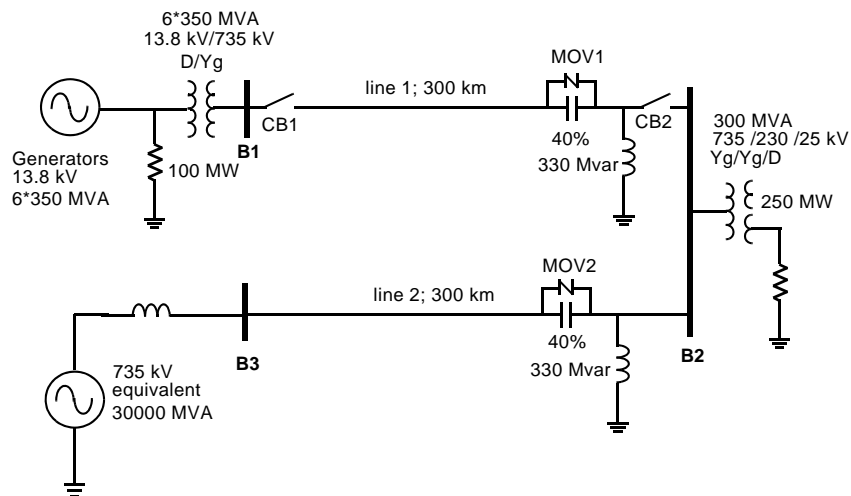

Figure 5-1: Series and Shunt Compensated Transmission System

To increase the transmission capacity, each line is series compensated by capacitors representing 40% of the line reactance. Both lines are also shunt compensated by a 330 Mvar shunt reactance. The shunt and series compensation equipment is located at the B2 substation where a 300 MVA-735/230 kV transformer feeds a 230 kV-250 MW load.

Each series compensation bank is protected by metal-oxide varistors (MOV1 and MOV2). The two circuit breakers of line 1 are shown as CB1 and CB2.

This power system is available in the power_3phseriescomp model. Load this model and save it in your working directory as case1.mdl to allow further modifications to the original system.

Compare the circuit modeled in SimPowerSystems (Figure 5-2) with the schematic diagram of Figure 5-1. The generators are simulated with a Simplified Synchronous Machine block. A Three-Phase Transformer (Two Windings) block and a Three-Phase Transformer (Three Windings) block are used to model the two transformers. Saturation is implemented on the transformer connected at bus B2.

The B1, B2, and B3 blocks are Three-Phase V-I Measurement blocks taken from the Measurements library. These blocks are reformatted and given a black background color to give them the appearance of bus bars. They output the three line-to-ground voltages and the three line currents. Open the dialog boxes of B1 and B2. Note how the blocks are programmed to output voltages in p.u. and currents in p.u./100 MVA. Notice also that the voltage and current signals are sent to internal Goto blocks by specifying signal labels. The signals are picked up by the From blocks in the Data Acquisition subsystem.

The fault is applied on line 1, on the line side of the capacitor bank. Open the dialog boxes of the Three-Phase Fault block and of the Three-Phase Breaker blocks CB1 and CB2. See how the initial breaker status and switching times are specified. A line-to-ground fault is applied on phase A at $t = 1$ cycle. The two circuit breakers that are initially closed are then open at $t = 5$ cycles, simulating a fault detection and opening time of 4 cycles. The fault is eliminated at $t = 6$ cycles, one cycle after the line opening.

735 kV Series Compensated Transmission System

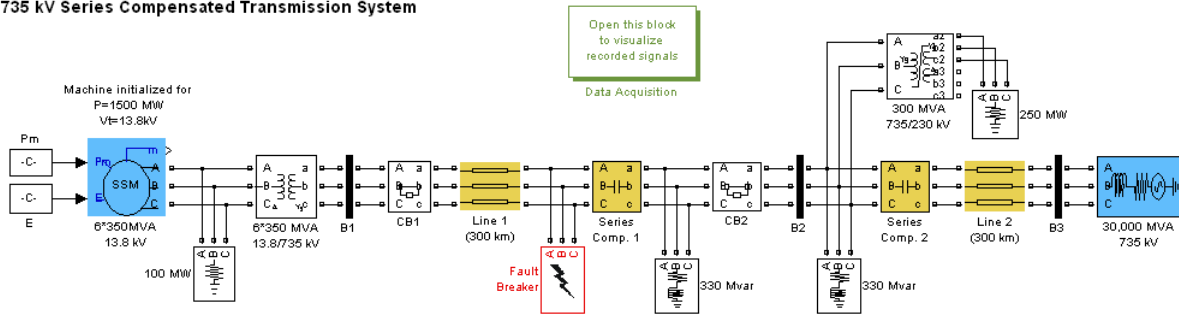

Figure 5-2: Series-Compensated System (power_3phseriescomp)

Series Compensation 1 Subsystem

Now, open the Series Compensation1 subsystem of the power_3phseriescomp model. The three-phase module consists of three identical subsystems, one for each phase. A note indicates how the capacitance value and the MOV protection level are calculated. Open the Series Compensation1/Phase A subsystem. You can see the details of the connections of the series capacitor and the Surge Arrester block (renamed MOV). The transmission line is 40% series compensated by a 62.8 μF capacitor. The capacitor is protected by the MOV block. If you open the dialog box of the MOV block, notice that it consists of 60 columns and that its protection level (specified at a reference current of 500 A/column or 30 kA total) is set at 298.7 kV. This voltage corresponds to 2.5 times the nominal capacitor voltage obtained at a nominal current of 2 kA RMS.

A gap is also connected in parallel with the MOV block. The gap is fired when the energy absorbed by the surge arrester exceeds a critical value of 30 MJ. To limit the rate of rise of capacitor current when the gap is fired, a damping RL circuit is connected in series. Open the Energy & Gap firing subsystem. It shows how you calculate the energy dissipated in the MOV by integrating the power (product of the MOV voltage and current).

When the energy exceeds the 30 MJ threshold, a closing order is sent to the Breaker block simulating the gap.

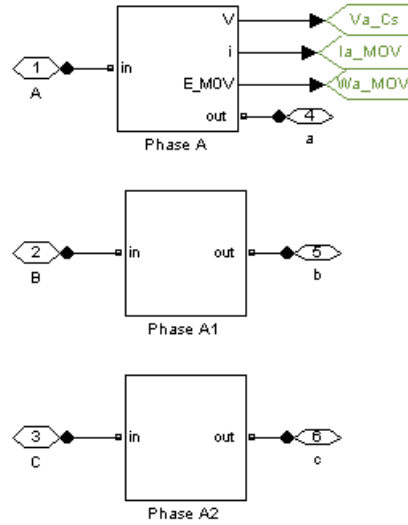

Series Compensation Module

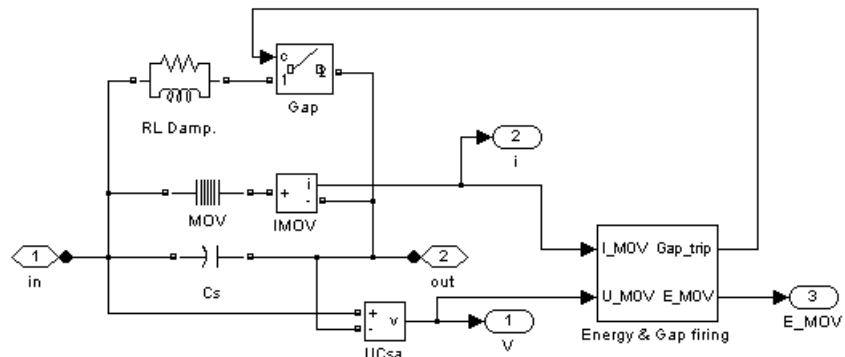

Series Compensation 1/PhaseA Subsystem

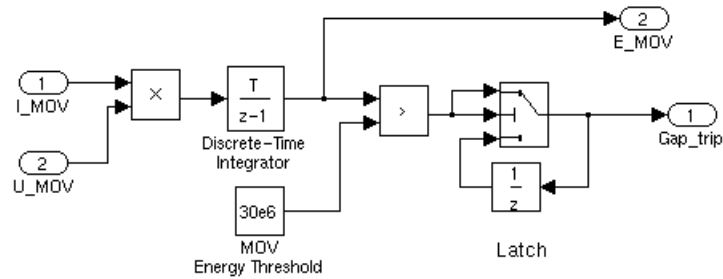

Series Compensation1/PhaseA Subsystem/Energy and Gap Firing

Three-Phase Saturable Transformer Model

Open the **300 MVA 735/230 kV Transformer** dialog box and notice that the current-flux saturation characteristic is set at

$$[0 \ 0 \ ; \ 0.0012 \ 1.2; \ 1 \ 1.45] \text{ in p.u.}$$

These data are the current and flux values at points 1, 2, and 3 of the piecewise linear approximation to the flux linkage curve shown here.

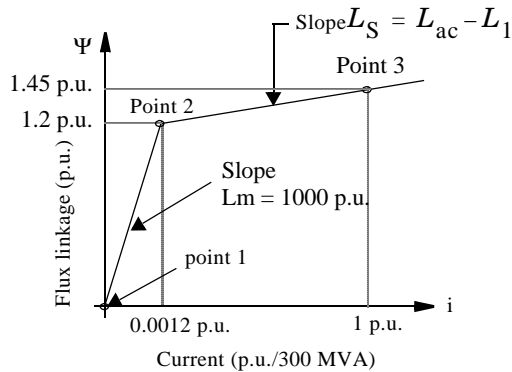
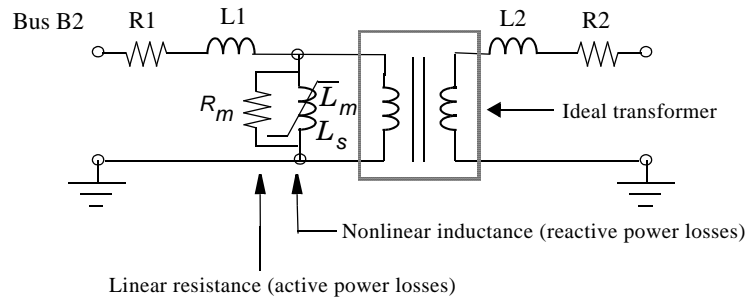

Saturable Transformer Model

The flux-current characteristic is approximated by the two segments shown in the graph here. The saturation knee point is 1.2 p.u. The first segment corresponds to the magnetizing characteristic in the linear region (for fluxes below 1.2 p.u.). At 1 p.u. voltage, the inductive magnetizing current is $0.0010/1.0 = 0.001$ p.u., corresponding to 0.1% reactive power losses.

The iron core losses (active power losses) are specified by the magnetization resistance $R_m = 1000$ p.u., corresponding to 0.1% losses at nominal voltage.

The slope of the saturation characteristic in the saturated region is 0.25 p.u. Therefore, taking into account the primary leakage reactance ($L_1 = 0.15$ p.u.), the air core reactance of the transformer seen from the primary winding is 0.4 p.u./300 MVA.

Setting the Initial Load Flow and Obtaining Steady State

Before performing transient tests, you must initialize your model for the desired load flow. Use the load flow utility of the Powergui to obtain an active power flow of 1500 MW out of the machine with a terminal voltage of 1 p.u. (13.8 kV).

Open the Powergui block and select **Load Flow and Machine Initialization**. A new window appears. In the upper right window you have the name of the only machine present in your system. Its **Bus type** should be PV Generator and the desired **Terminal Voltage** should already be set to the nominal voltage of 13800 V. In the **Active Power** field, enter 1500e6 as the desired output power. Click the **Execute load flow** button. Once the load flow is solved, the phasors of AB and BC machine voltages as well as currents flowing in phases A and B are updated in the left window. The required mechanical power to drive the machine is displayed in watts and in p.u., and the required excitation voltage E is displayed in p.u.

```
Pmec          1.5159e9 W [0.72184 p.u.]  
E/Vf          1.0075 p.u.
```

Notice that Constant blocks containing these two values are already connected to the P_m and E inputs of the machine block. If you open the Machine block dialog box, you see that the machine initial conditions (initial speed deviation $dw = 0$; internal angle theta, current magnitudes, and phase angles) are automatically transferred in the last line.

Once the load flow is performed, you can obtain the corresponding voltage and current measurements at the different buses. In the Powergui block, select **Steady State Voltages and Currents**. You can observe, for example, the phasors for phase A voltages at buses B1, B2, and B3 and the current entering line 1 at bus B1.

```
B1/Va          6.088e5 V ; 18.22 degrees  
B2/Va          6.223e5 V ; 9.26 degrees  
B3/Va          6.064e5 V ; 2.04 degrees  
B1/Ia          1560 A ; 30.50 degrees
```

The active power flow for phase A entering line 1 is therefore

$$P_a = V_a \cdot I_a \cdot \cos(\phi_a) = \frac{608.8 \text{ kV}}{\sqrt{2}} \cdot \frac{1.56 \text{ kA}}{\sqrt{2}} \cos(30.50 - 18.22) = 464 \text{ MW}$$

corresponding to a total of $464 * 3 = 1392$ MW for the three phases.

Transient Performance for a Line Fault

To speed up the simulation, you need to discretize the power system. The sample time is specified in the Powergui block as a variable Ts. The sample time Ts=50e-6 has already been defined in the Model Initialization function in the Callbacks of the Model Properties. The sample time Ts is also used in the Discrete Integrator block of the MOV energy calculator controlling the gap.

Ensure that the simulation parameters are set as follows.

Stop time	0.2
Solver options type	Fixed-step; discrete (no continuous state)
Fixed step size	Ts

Line-to-Ground Fault Applied on Line 1

Ensure that the fault breaker is programmed for a line-to-ground fault on phase A. Start the simulation and observe the waveforms on the three scopes. These waveforms are shown here.

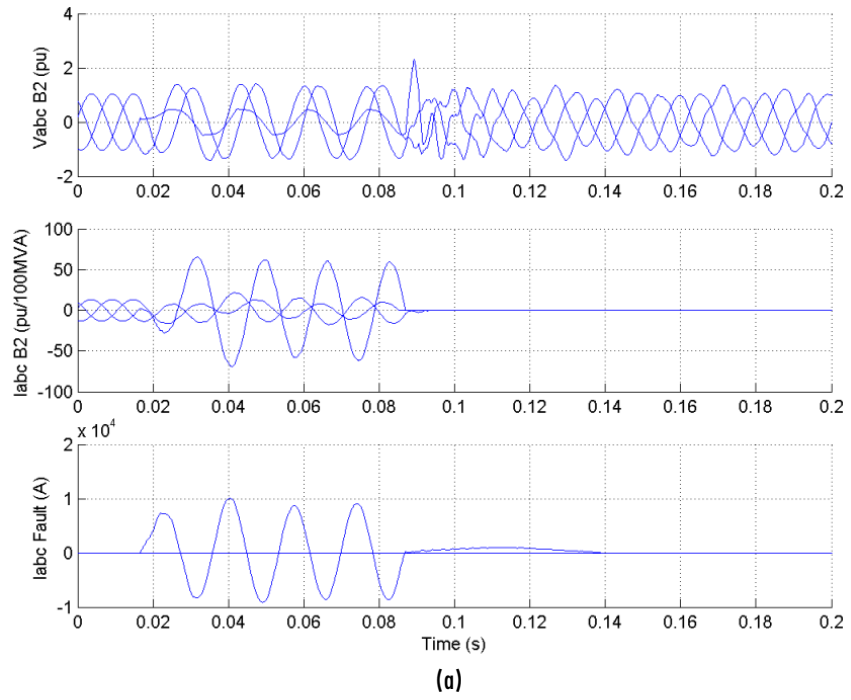

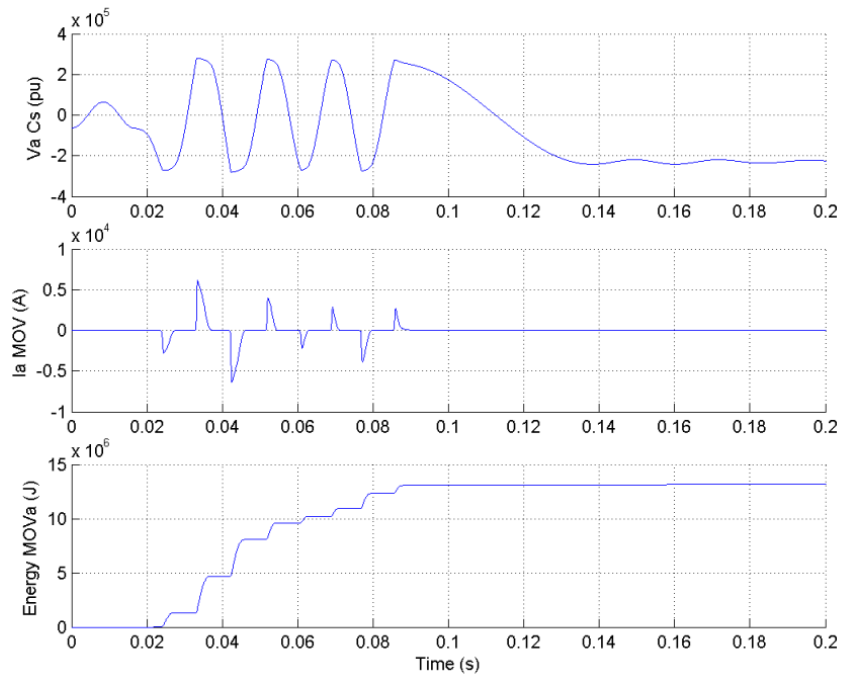

(b)

Simulation Results for a Four-Cycle Line-to-Ground Fault at the End of Line 1

The simulation starts in steady state. At the $t = 1$ cycle, a line-to-ground fault is applied and the fault current reaches 10 kA (a: trace 3). During the fault, the MOV conducts at every half cycle (b: trace 2) and the energy dissipated in the MOV (b: trace 3) builds up to 13 MJ. At $t = 5$ cycles the line protection relays open breakers CB1 and CB2 (see the three line currents on trace 2) and the energy stays constant at 13 MJ. As the maximum energy does not exceed the 30 MJ threshold level, the gap is not fired. At the breaker opening, the fault current drops to a small value and the line and series capacitance starts to discharge through the fault and the shunt reactance. The fault current extinguishes at the first zero crossing after the opening order given to the fault breaker ($t = 6$ cycles). Then the series capacitor stops discharging and its voltage oscillates around 220 kV (b: trace 1).

Three-Phase-to-Ground Fault Applied on Line 1

Double-click the Three-Phase Fault block to open the **Block Parameters** dialog box. Select the **Phase B Fault** and **Phase C Fault** check boxes, so that you now have a three-phase-to-ground fault.

Restart the simulation. The resulting waveforms are shown.

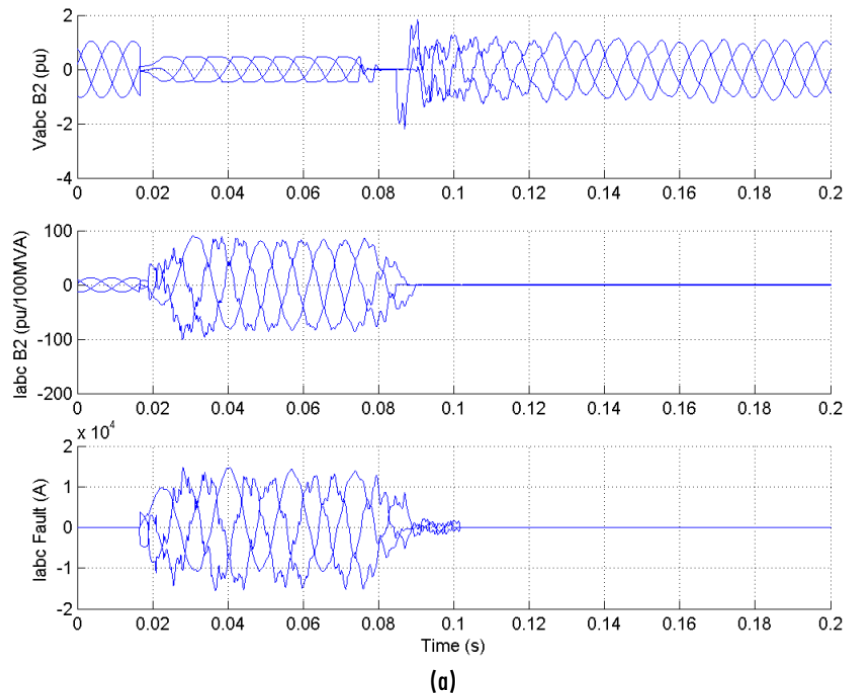

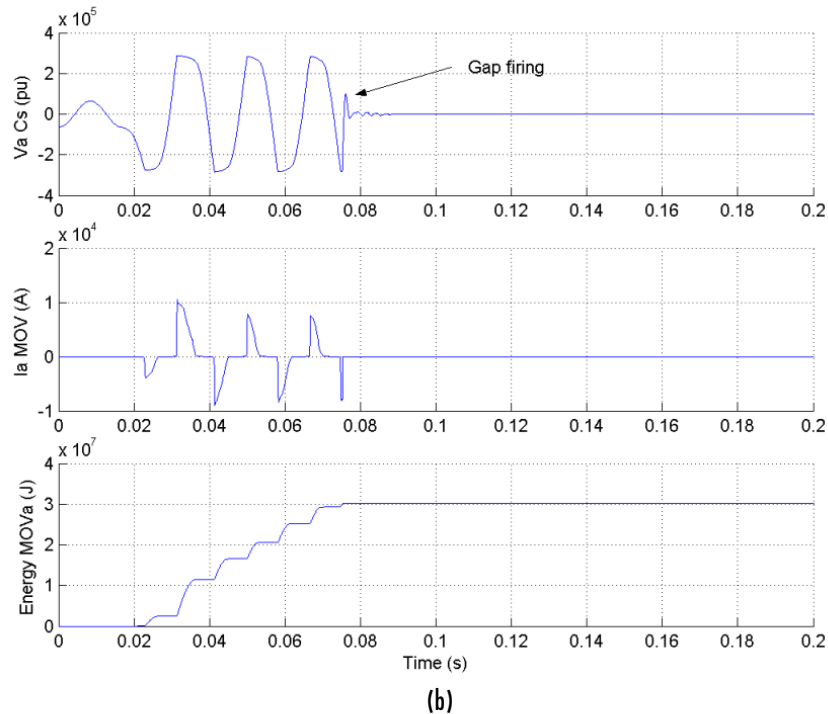

Simulation Results for a Four-Cycle Three-Phase-to-Ground Fault at the End of Line 1

Note that during the fault the energy dissipated in the MOV (b: trace 3) builds up faster than in the case of a line-to-ground fault. The energy reaches the 30 MJ threshold level after three cycles, one cycle before the opening of the line breakers. As a result, the gap is fired and the capacitor voltage (b: trace 1) quickly discharges to zero through the damping circuit.

Frequency Analysis

One particular characteristic of series-compensated systems is the existence of subsynchronous modes (poles and zeros of the system impedance below the fundamental frequency). Dangerous resonances can occur if the mechanical torsion modes of turbine/generator shafts are in the vicinity of the zeros of the

system impedance. Also, high subsynchronous voltages due to impedance poles at subsynchronous frequencies drive transformers into saturation. The transformer saturation due to subsynchronous voltages is illustrated at the end of this case study. The torque amplification on a thermal machine is illustrated in another demonstration (see the `power_thermal` model).

Now measure the positive-sequence impedance versus frequency seen from bus B2.

The section “Analyzing a Simple Circuit” on page 1-16 explains how the Impedance Measurement block allows you to compute the impedance of a linear system from its state-space model. However, your `case1` model contains several nonlinear blocks (machine and saturation of transformers). If you connect the Impedance Measurement block to your system, all nonlinear blocks are ignored. This is correct for the transformer, but you get the impedance of the system with the machine disconnected. Before measuring the impedance, you must therefore replace the machine block with an equivalent linear block having the same impedance.

Delete the Simplified Synchronous Machine block from your `case1` model and replace it with the Three-Phase Source block from the Electrical Sources library. Open the block dialog box and set the parameters as follows to get the same impedance value ($L = 0.22$ p.u./ ($6 * 350$ MVA) Quality factor = 15).

Phase-to-phase rms voltage	13.8e3
Phase angle of phase A	0
Frequency (Hz)	60
Internal connection Yg	Specify impedance using short-circuit level
3-phase short-circuit level	6*350e6
Base voltage	13.8e3
X/R ratio	15

Save your modified model as `case1Zf.mdl`.

Open the Measurements library of **powerlib** and copy the Impedance Measurement block into your model. This block is used to perform the impedance measurement. Connect the two inputs of this block between phase A and phase B of the B2 bus. Measuring the impedance between two phases

gives two times the positive-sequence impedance. Therefore you must apply a factor of 1/2 to the impedance to obtain the correct impedance value. Open the dialog box and set the multiplication factor to 0.5.

In the Powergui block, select **Impedance vs Frequency Measurement**. A new window opens, showing your Impedance Measurement block name. Fill in the frequency range by entering 0:500. Select the linear scales to display Z magnitude vs. frequency plot. Click the **Save data to workspace** button and enter Zcase1 as the variable name to contain the impedance vs. frequency. Click the **Display** button.

When the calculation is finished, the magnitude and phase as a function of frequency are displayed in the two graphs on the window. If you look in your workspace, you should have a variable named Zcase1. It is a two-column matrix containing frequency in column 1 and complex impedance in column 2.

The impedance as a function of frequency (magnitude and phase) is shown here.

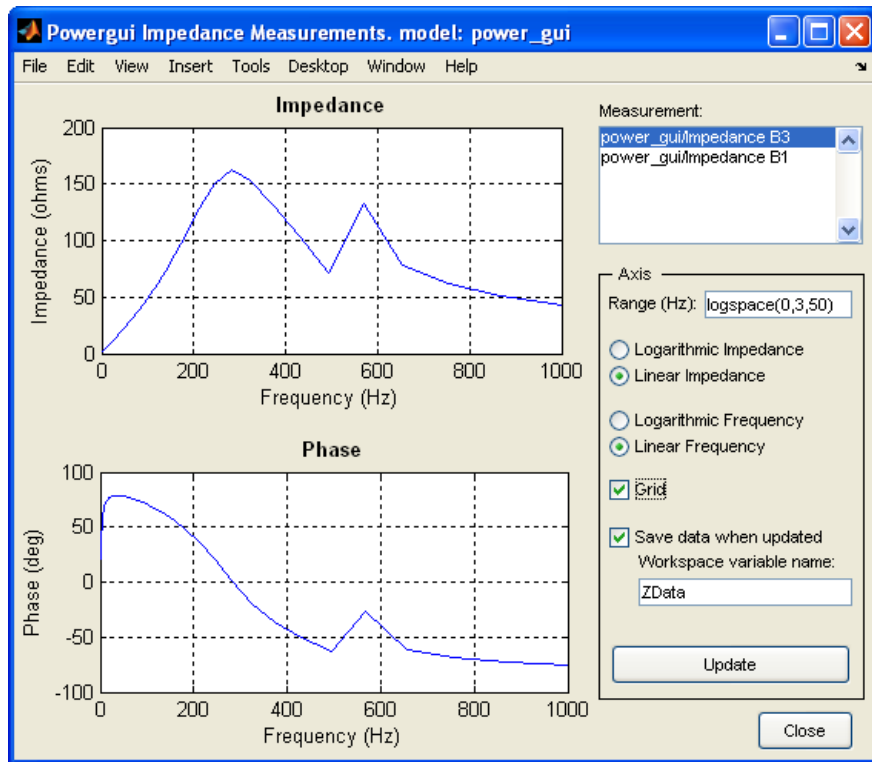

Impedance vs. Frequency Seen from Bus B2

You can observe three main modes: 9 Hz, 175 Hz, and 370 Hz. The 9 Hz mode is mainly due to a parallel resonance of the series capacitor with the shunt inductors. The 175 Hz and 370 Hz modes are due to the 600 km distributed parameter line. These three modes are likely to be excited at fault clearing.

If you zoom in on the impedance in the 60 Hz region, you can find the system's short-circuit level at bus B2. You should find a value of 58Ω at 60 Hz, corresponding to a three-phase short-circuit power of $(735 \text{ kV})^2 / 58 = 9314 \text{ MVA}$.

Transient Performance for a Fault at Bus B2

The configuration of the substation circuit breakers normally allows clearing a fault at the bus without losing the lines or the transformers. You now modify your case1 model to perform a three-cycle, three-phase-to-ground fault at bus B2:

- 1 Disconnect the Three-Phase Fault block and reconnect it so that the fault is now applied on bus B2.
- 2 Open the Three-Phase Fault block and make the following modifications in its dialog box:

Phase A, Phase B, Phase C, All selected

Ground Faults

Transition times [2/60 5/60]

Transition status [1, 0, 1...] (0/1)

You have now programmed a three-phase-to-ground fault applied at the $t = 2$ cycles.

- 3 Open the dialog boxes of circuit breakers CB1 and CB2 and make the following modifications:

Switching of Phase A Not selected

Switching of Phase B Not selected

Switching of Phase C Not selected

The circuit breakers are not switched anymore. They stay at their initial state (closed).

- 4 In the Data Acquisition subsystem, insert a Selector block (from the Simulink Signals & Systems library) in the Vabc_B2 output of bus B2 connected to the scope. Set the **Elements** parameter to 1. This allows you to see the phase A voltage clearly on the scope.
- 5 You now add blocks to read the flux and the magnetization current of the saturable transformer connected at bus B2.

Copy the Multimeter block from the Measurements library into your case1 model. Open the **Transformer** dialog box. In the **Measurements** list, select Flux and magnetization current. Open the Multimeter block. Verify that you have six signals available. Select flux and magnetization current on phase A, and click **OK**.

- 6** You now have two signals available at the output of the Multimeter block. Use a Demux block to send these two signals on a two-trace scope.
- 7** In the **Simulation** → **Simulation parameters** dialog box, change the stop time to 0.5. This longer simulation time allows you to observe the expected low-frequency modes (9 Hz). Start the simulation.

The resulting waveforms are plotted here.

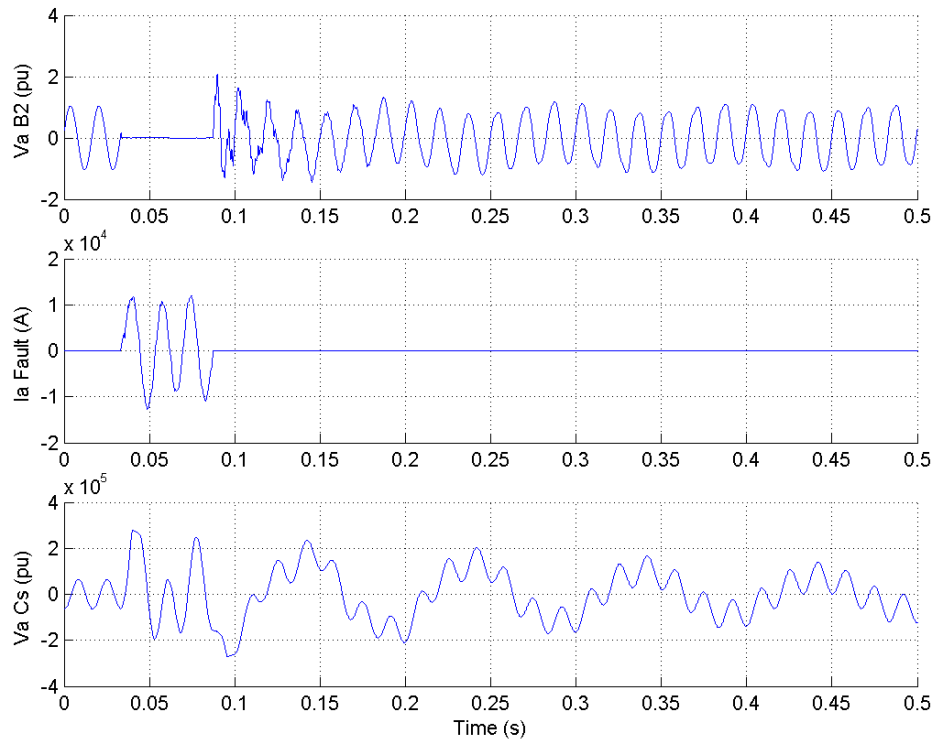

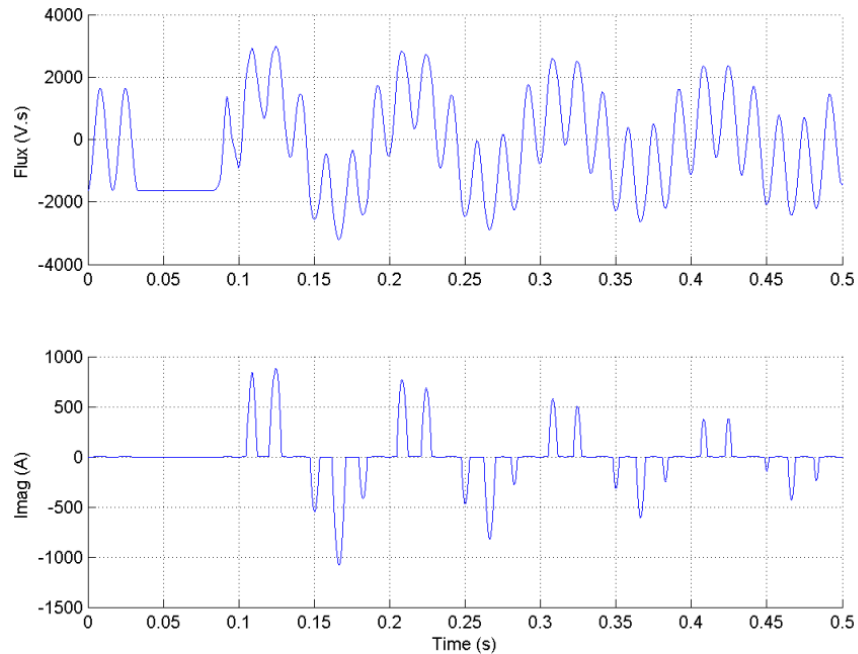

Simulation Results for a Three-Cycle Three-Phase-to-Ground Fault at Bus B2

The 9 Hz subsynchronous mode excited at fault clearing is clearly seen on the phase A voltage at bus B2 (trace 1) and capacitor voltage (trace 3). The 9 Hz voltage component appearing at bus B2 drives the transformer into saturation, as shown on the transformer magnetizing current (trace 5). The flux in phase A of the transformer is plotted on trace 4. At fault application the voltage at transformer terminals drops to zero and the flux stays constant during the fault.

At fault clearing, when the voltage recovers, the transformer is driven into saturation as a result of the flux offset created by the 60 Hz and 9 Hz voltage components. The pulses of the transformer magnetizing current appear when the flux exceeds its saturation level. This current contains a 60 Hz reactive component modulated at 9 Hz.

Thyristor-Based Static Var Compensator

The example described in this section illustrates application of SimPowerSystems to study the steady-state and dynamic performance of a static var compensator (SVC) on a transmission system. The SVC is a shunt device of the Flexible AC Transmission Systems (FACTS) family using power electronics. It regulates voltage by generating or absorbing reactive power. If you are not familiar with the SVC, please refer to the Static Var Compensator (Phasor Type) block documentation, which describes the SVC principle of operation.

The Static Var Compensator (Phasor Type) block of the FACTS library is a simplified model that can simulate any SVC topology. You can use it with the phasor simulation option of the Powergui block for studying dynamic performance and transient stability of power systems. Due to low frequencies of electromechanical oscillations in large power systems (typically 0.02 Hz to 2 Hz), this type of study usually requires simulation times of 30-40 seconds or more.

The SVC model described in this example is rather a detailed model of a particular SVC topology (using thyristor-controlled reactor (TCR) and thyristor-switched capacitors (TSCs)) with full representation of power electronics. This type of model requires discrete simulation at fixed time steps (50 μ s in this case) and it is used typically for studying the SVC performance on a much smaller time range (a few seconds). Typical applications include optimizing of the control system, impact of harmonics, transients and stresses on power components during faults.

Description of the SVC

The single-line diagram of the modeled SVC is shown on Figure 5-3. It represents a 300 Mvar SVC connected on a 735 kV transmission system.

This example is available in the `power_svc_1tcr3tsc` model. Load this model and save it in your working directory as `case2.mdl` to allow further modifications to the original system. This model is shown on Figure 5-4.

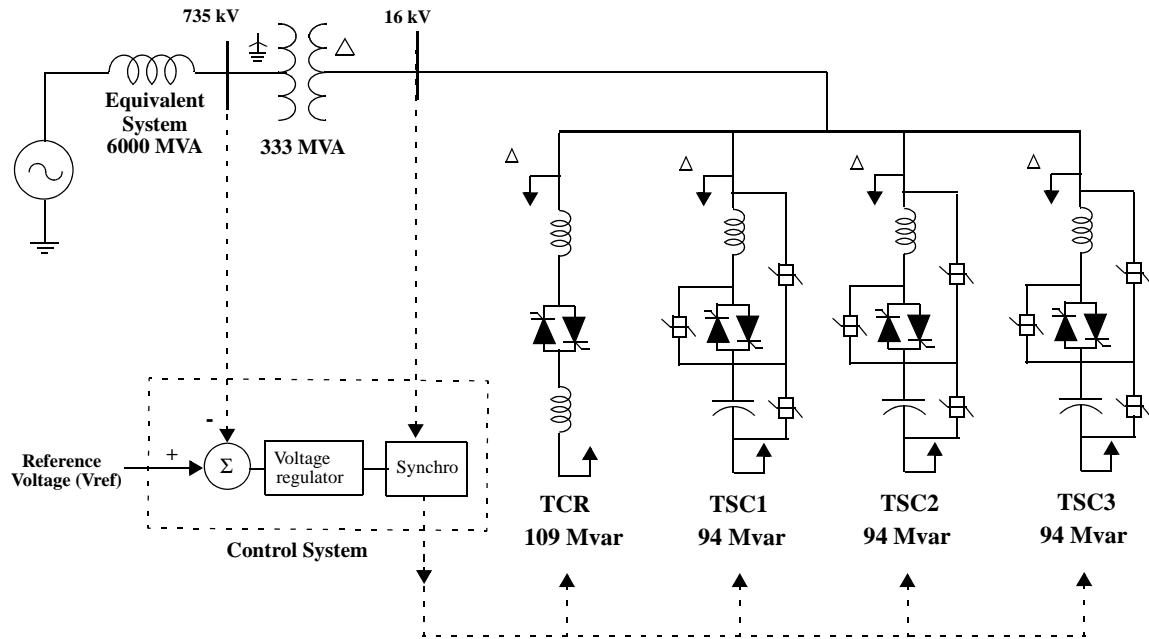

Figure 5-3: Single-Line Diagram of the SVC

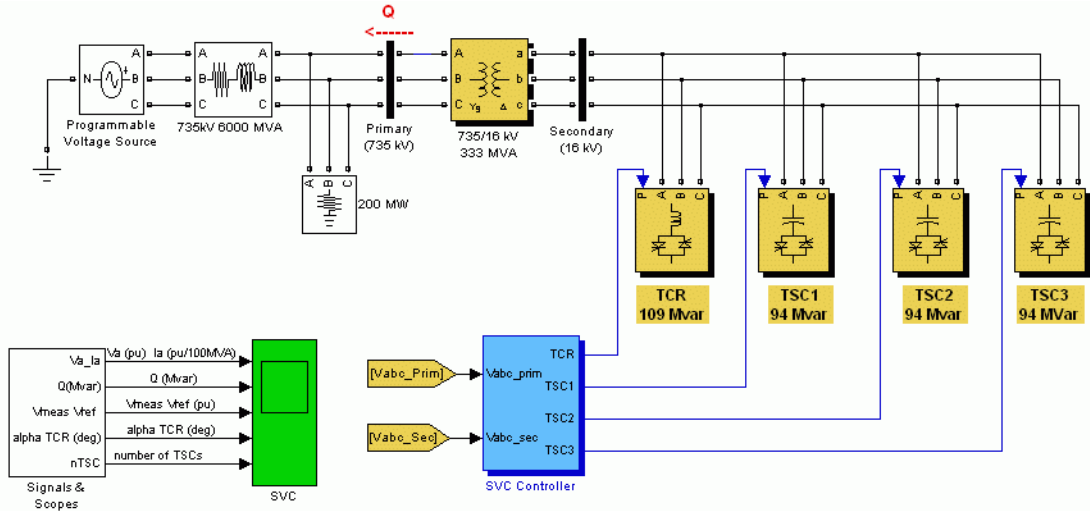

Figure 5-4: SPS Model of the 300 Mvar SVC on a 735 kV Power System (power_svc_1tcr3tscs)

SVC Power Components

The SVC consists of a 735 kV/16 kV, 333 MVA coupling transformer, one 109 Mvar TCR bank and three 94 Mvar TSC banks (TSC1 TSC2 TSC3) connected on the secondary side of the transformer.

Switching the TSCs in and out allows a discrete variation of the secondary reactive power from zero to 282 Mvar capacitive (at 16 kV) by steps of 94 Mvar, whereas phase control of the TCR allows a continuous variation from zero to 109 Mvar inductive. Taking into account the leakage reactance of the transformer (0.15 p.u.), the SVC equivalent susceptance seen from the primary side can be varied continuously from -1.04 pu/100 MVA (fully inductive) to +3.23 pu/100 Mvar (fully capacitive).

The SVC Controller monitors the primary voltage and sends appropriate pulses to the 24 thyristors (6 thyristors per three-phase bank) to obtain the susceptance required by the voltage regulator.

Use **Look under Mask** to see how the TCR and TSC subsystems are built. Each three-phase bank is connected in delta so that, during normal balanced operation, the zero-sequence triplen harmonics (3rd, 9th,...) remain trapped inside the delta, thus reducing harmonic injection into the power system.

The power system is represented by an inductive equivalent (6000 MVA short circuit level) and a 200-MW load. The internal voltage of the equivalent system can be varied by means of a Three-Phase Programmable Voltage Source block to observe the SVC dynamic response to changes in system voltage.

SVC Control System

Open the SVC Controller (see subsystem in Figure 5-5).

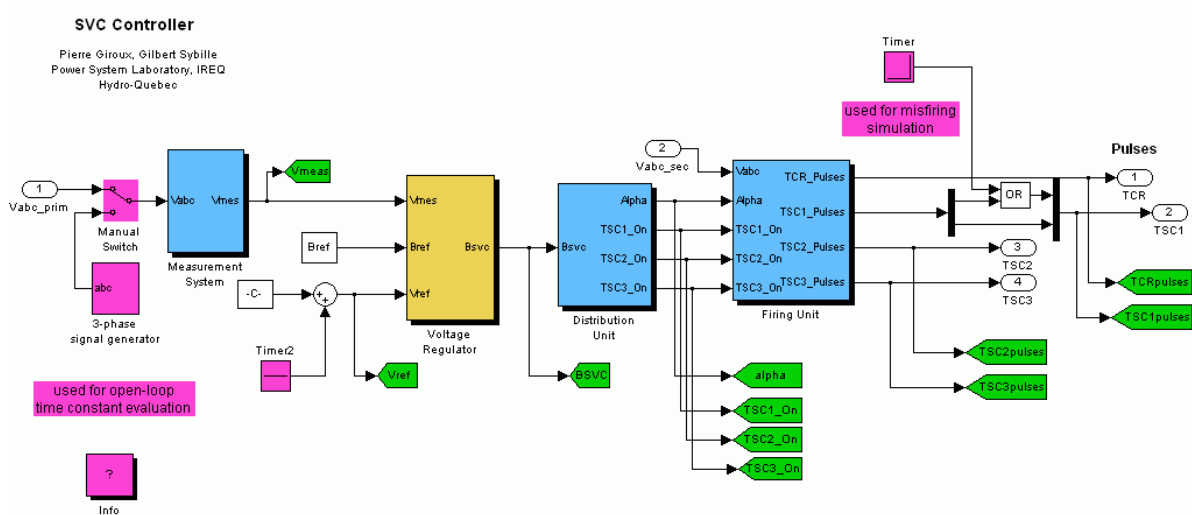

Figure 5-5: SVC Control System

The SVC control system consists of the following four main modules:

- Measurement System measures the positive-sequence primary voltage. This system uses discrete Fourier computation technique to evaluate fundamental voltage over a one-cycle running average window. The voltage

measurement unit is driven by a phase-locked loop (PLL) to take into account variations of system frequency.

- Voltage Regulator uses a PI regulator to regulate primary voltage at the reference voltage (1.0 p.u. specified in the SVC Controller block menu). A voltage droop is incorporated in the voltage regulation to obtain a V-I characteristic with a slope (0.01 pu/100 MVA in this case). Therefore, when the SVC operating point changes from fully capacitive (+300 Mvar) to fully inductive (-100 Mvar) the SVC voltage varies between $1-0.03=0.97$ p.u. and $1+0.01=1.01$ pu.
- Distribution Unit uses the primary susceptance B_{svc} computed by the voltage regulator to determine the TCR firing angle α and the status (on/off) of the three TSC branches. The firing angle α as a function of the TCR susceptance B_{TCR} is implemented by a look-up table from the equation

$$B_{\text{TCR}} = \frac{2(\pi - \alpha) + \sin(2\alpha)}{\pi}$$

where B_{TCR} is the TCR susceptance in p.u. of rated TCR reactive power (109 Mvar)

- Firing Unit consists of three independent subsystems, one for each phase (AB, BC and CA). Each subsystem consists of a PLL synchronized on line-to-line secondary voltage and a pulse generator for each of the TCR and TSC branches. The pulse generator uses the firing angle α and the TSC status coming from the Distribution Unit to generate pulses. The firing of TSC branches can be synchronized (one pulse is sent at positive and negative thyristors at every cycle) or continuous. The synchronized firing mode is usually the preferred method because it reduces harmonics faster. Verify that the **Synchronized** firing mode has been selected in the **Firing Unit** dialog box.

Steady State and Dynamic Performance of the SVC

Now observe the steady state waveforms and the SVC dynamic response when the system voltage is varied. Open the **Programmable Voltage Source** menu and look at the sequence of voltage steps that are programmed. Also, open the **SVC Controller** block menu and check that the SVC is in Voltage regulation mode with a reference voltage of 1.0 p.u. Run the simulation and observe waveforms on the SVC Scope block. These waveforms are reproduced below.

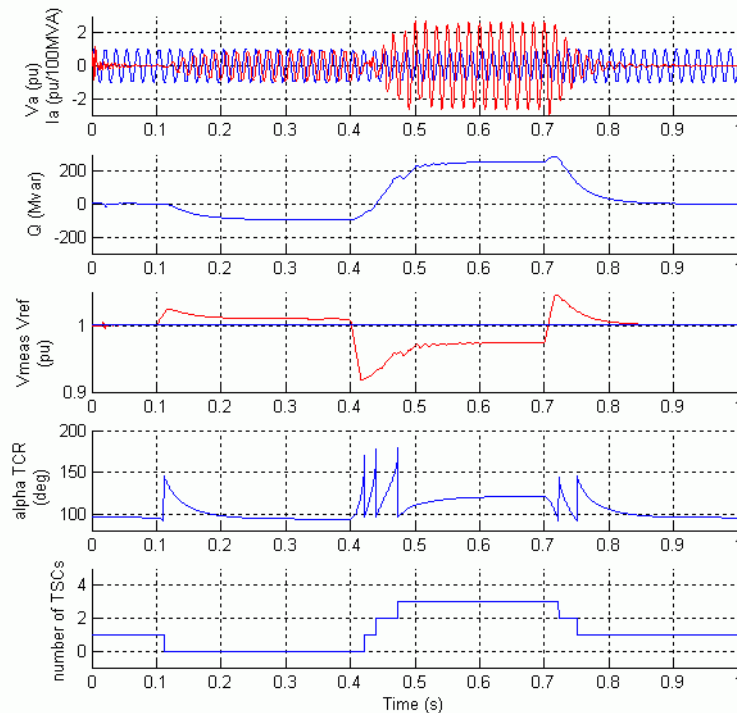

Waveforms Illustrating SVC Dynamic Response to System Voltage Steps

Initially the source voltage is set at 1.004 pu, resulting in a 1.0 p.u. voltage at SVC terminals when the SVC is out of service. As the reference voltage V_{ref} is set to 1.0 pu, the SVC is initially floating (zero current). This operating point is obtained with TSC1 in service and TCR almost at full conduction ($\alpha = 96$ degrees).

At $t=0.1$ s voltage is suddenly increased to 1.025 pu. The SVC reacts by absorbing reactive power ($Q=-95$ Mvar) to bring the voltage back to 1.01 pu. The 95% settling time is approximately 135 ms. At this point all TSCs are out of service and the TCR is almost at full conduction ($\alpha = 94$ degrees).

At $t=0.4$ s the source voltage is suddenly lowered to 0.93 pu. The SVC reacts by generating 256 Mvar of reactive power, thus increasing the voltage to 0.974 pu.

At this point the three TSCs are in service and the TCR absorbs approximately 40% of its nominal reactive power ($\alpha = 120$ degrees).

Observe on the last trace of the scope how the TSCs are sequentially switched on and off. Each time a TSC is switched on the TCR α angle changes from 180 degrees (no conduction) to 90 degrees (full conduction). Finally, at $t=0.7$ s the voltage is increased to 1.0 p.u. and the SVC reactive power is reduced to zero.

You may open the Signal & Scopes subsystem to observe additional waveforms. The TCR voltage and current in branch AB as well as thyristors pulses are displayed on the TCR AB scope. The figure below zooms on three cycles when the firing angle α is 120 degrees.

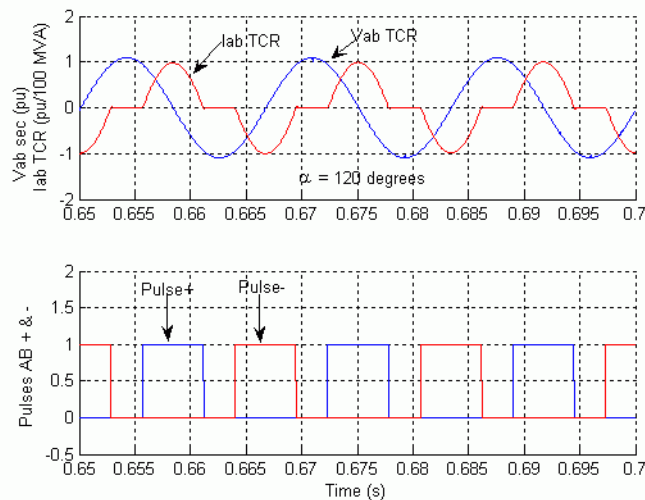

Steady State Voltage and Current in TCR AB

Misfiring of TSC1

The final case study simulates a TSC misfiring.

Each time a TSC is switched off a voltage remains trapped across the TSC capacitors. If you look at the TSC1 Misfiring scope inside the Signals & Scope subsystem, you can observe the TSC1 voltage (first trace) and the TSC1 current (second trace) for branch AB. The voltage across the positive thyristor (thyristor conducting the positive current) is shown on the third trace and the pulses sent to this thyristor are shown on the fourth trace. Notice that the

positive thyristor is fired at maximum negative TSC voltage, when the valve voltage is minimum.

If by mistake the firing pulse is not sent at the right time, very large overcurrents can be observed in the TSC valves. Look inside the SVC Controller block for how a misfiring can be simulated on TSC1. A Timer block and an OR block are used to add pulses to the normal pulses coming from the Firing Unit.

Open the Timer block menu and remove the 100 multiplication factor. The timer is now programmed to send a misfiring pulse lasting one sample time at time $t = 0.121$ s.

Restart simulation. Waveforms observed on the TSC1 Misfiring scope are reproduced below.

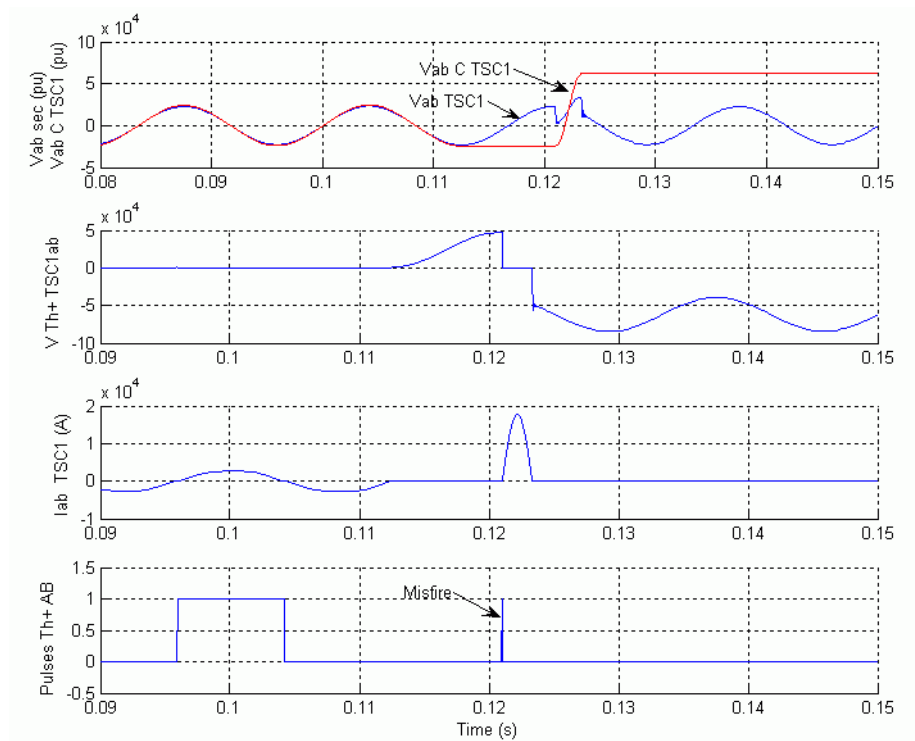

TSC Voltages and Current Resulting from Misfiring on TSC1

Observe that the misfiring pulse is sent when the valve voltage is maximum positive immediately after the TSC has blocked. This thyristor misfiring produces a large thyristor overcurrent (18 kA or 6.5 times the nominal peak current). Also, immediately after the thyristor has blocked, the thyristor voltage reaches 85 kV (3.8 times the nominal peak voltage). to prevent such overcurrents and overvoltages, thyristor valves are normally protected by metal oxide arresters (not simulated here).

GTO-Based STATCOM

The example described in this section illustrates application of SimPowerSystems to study the steady-state and dynamic performance of a static synchronous compensator (STATCOM) on a transmission system. The STATCOM is a shunt device of the Flexible AC Transmission Systems (FACTS) family using power electronics. It regulates voltage by generating or absorbing reactive power. If you are not familiar with the STATCOM, please refer to the Static Synchronous Compensator (Phasor Type) block documentation, which describes the STATCOM principle of operation.

Depending on the power rating of the STATCOM, different technologies are used for the power converter. High power STATCOMs (several hundreds of Mvars) normally use GTO-based, square-wave voltage-sourced converters (VSC), while lower power STATCOMs (tens of Mvars) use IGBT-based (or IGCT-based) pulse-width modulation (PWM) VSC. The Static Synchronous Compensator (Phasor Type) block of the FACTS library is a simplified model, which can simulate different types of STATCOMs. You can use it with the phasor simulation option of the Powergui block for studying dynamic performance and transient stability of power systems. Due to low frequencies of electromechanical oscillations in large power systems (typically 0.02 Hz to 2 Hz), this type of study usually requires simulation times of 30-40 seconds or more.

The STATCOM model described in this example is rather a detailed model with full representation of power electronics. It uses a square-wave, 48-pulse VSC and interconnection transformers for harmonic neutralization. This type of model requires discrete simulation at fixed time steps (25 μ s in this case) and it is used typically for studying the STATCOM performance on a much smaller time range (a few seconds). Typical applications include optimizing of the control system and impact of harmonics generated by converter.

Description of the STATCOM

The STATCOM described in this example is available in the `power_statcom_gto48p` model. Load this model and save it in your working directory as `case3.mdl` to allow further modifications to the original system. This model shown on Figure 5-6 represents a three-bus 500 kV system with a 100 Mvar STATCOM regulating voltage at bus B1.

The internal voltage of the equivalent system connected at bus B1 can be varied by means of a Three-Phase Programmable Voltage Source block to observe the STATCOM dynamic response to changes in system voltage.

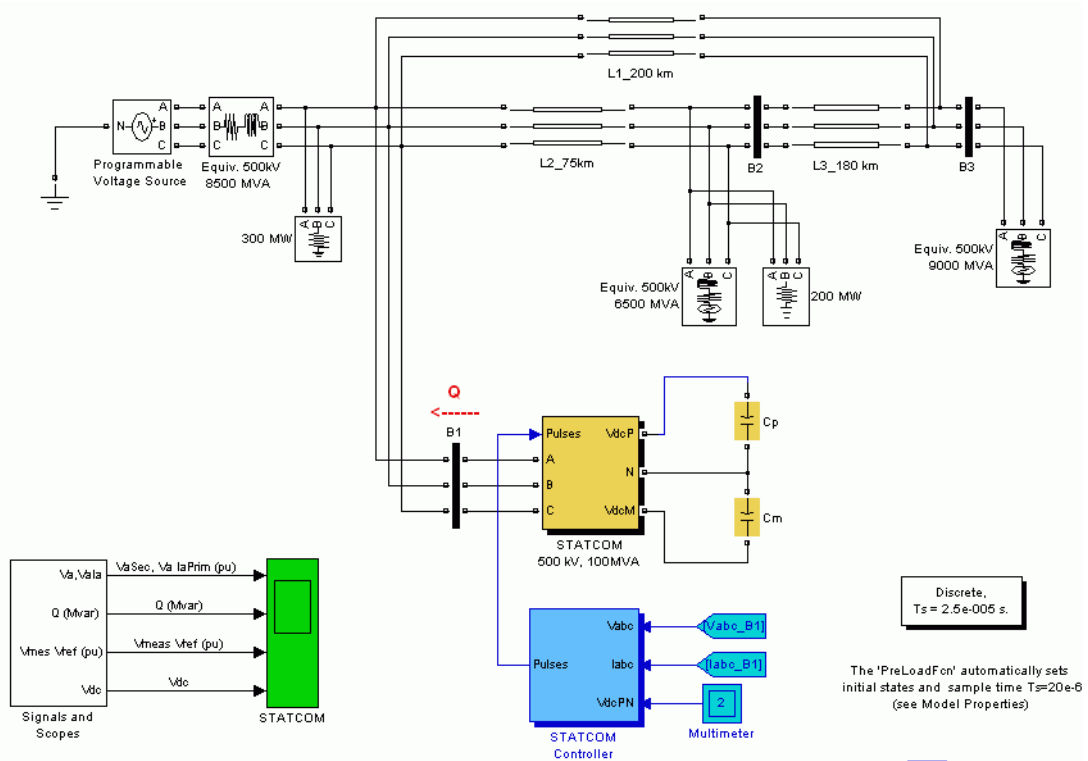

Figure 5-6: SPS Model of the 100 Mvar STATCOM on a 500 kV Power System (power_statcom_gto48p)

STATCOM Power Component

The STATCOM consists of a three-level 48-pulse inverter and two series-connected 3000 μF capacitors which act as a variable DC voltage source. The variable amplitude 60 Hz voltage produced by the inverter is synthesized from the variable DC voltage which varies around 19.3 kV.

Double-click on the STATCOM 500kV 100 MVA block (see subsystem in Figure 5-7).

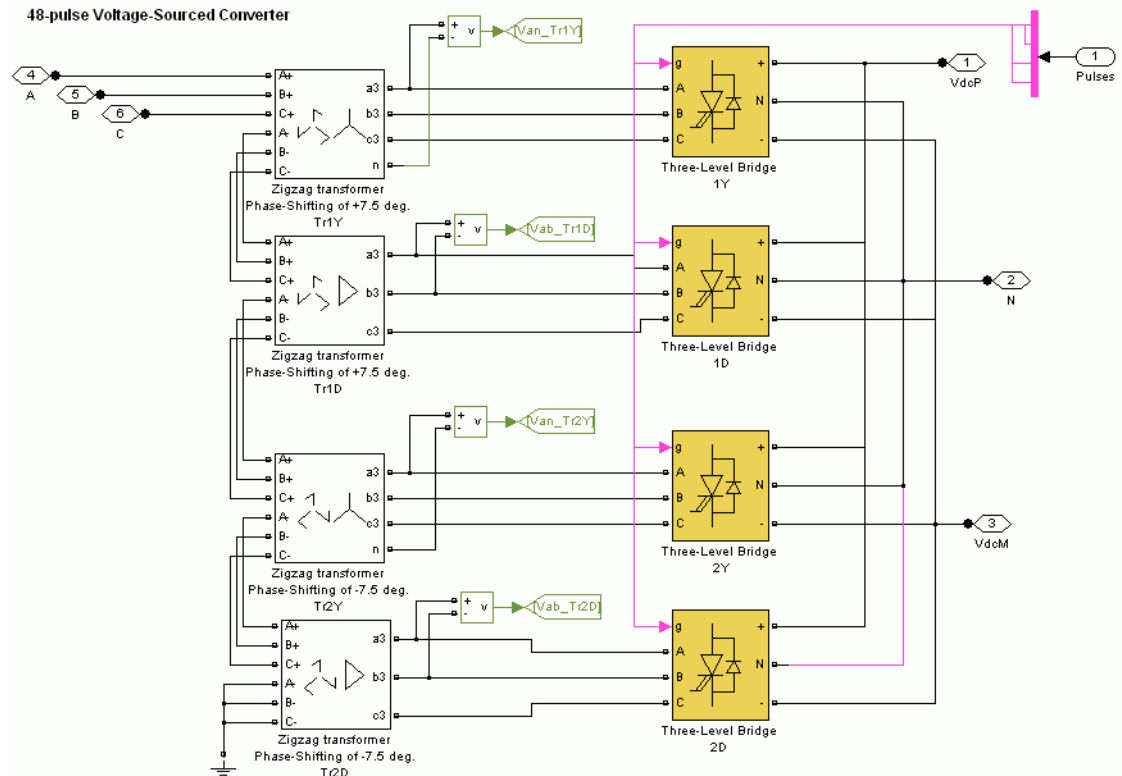

Figure 5-7: 48-Pulse Three-Level Inverter

The STATCOM uses this circuit to generate the inverter voltage V2 voltage mentioned in the Static Synchronous Compensator (Phasor Type) block documentation. It consists of four 3-phase 3-level inverters coupled with four phase shifting transformers introducing phase shift of ± 7.5 degrees.

Except for the 23rd and 25th harmonics, this transformer arrangement neutralizes all odd harmonics up to the 45th harmonic. Y and D transformer secondaries cancel harmonics $5+12n$ (5, 17, 29, 41,...) and $7+12n$ (7, 19, 31,

43,...). In addition, the 15° phase shift between the two groups of transformers (Tr1Y and Tr1D leading by 7.5° , Tr2Y and Tr2D lagging by 7.5°) allows cancellation of harmonics $11+24n$ (11, 35,...) and $13+24n$ (13, 37,...). Considering that all $3n$ harmonics are not transmitted by the transformers (delta and ungrounded Y), the first harmonics that are not canceled by the transformers are therefore the 23rd, 25th, 47th and 49th harmonics. By choosing the appropriate conduction angle for the three-level inverter ($\sigma = 172.5^\circ$), the 23rd and 25th harmonics can be minimized. The first significant harmonics generated by the inverter will then be 47th and 49th. Using a bipolar DC voltage, the STATCOM thus generates a 48-step voltage approximating a sine wave.

The following figure reproduces the primary voltage generated by the STATCOM 48-pulse inverter as well as its harmonics contents.

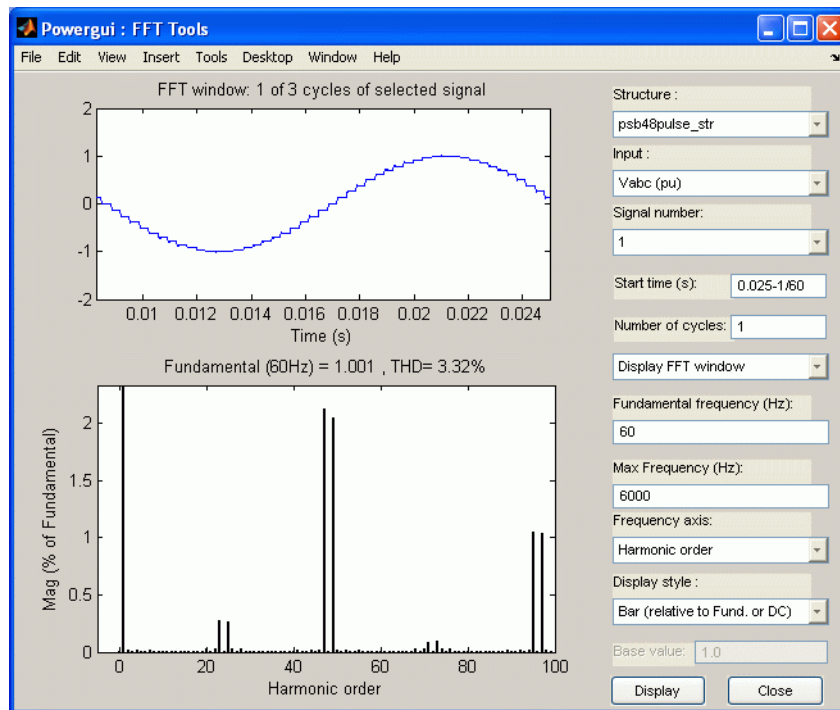

Frequency Spectrum of Voltage Generated by 48-Pulse Inverter at No Load

Powergui block. FFT uses one cycle of inverter voltage during the no-load operation and a 0-6000 Hz frequency range.

STATCOM Control System

Open the STATCOM Controller (see subsystem in Figure 5-8).

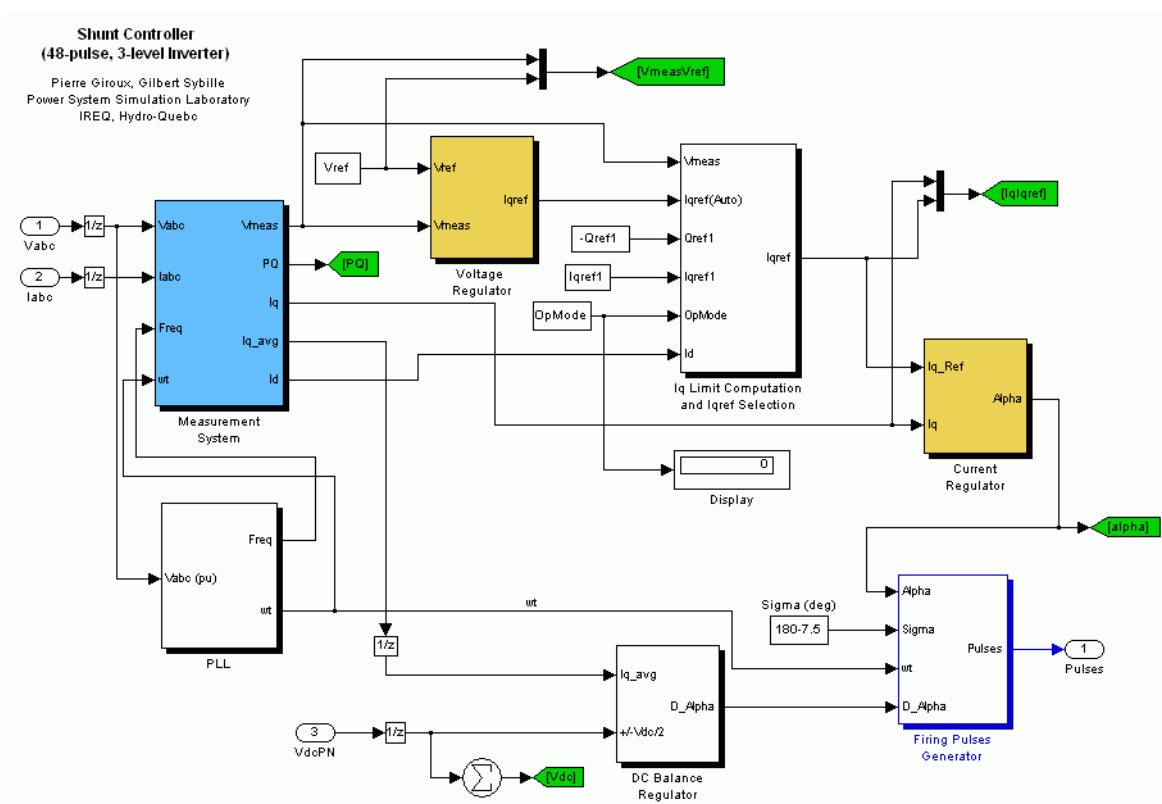

Figure 5-8: STATCOM Control System

The control system task is to increase or decrease the capacitor DC voltage, so that the generated AC voltage has the correct amplitude for the required reactive power. The control system must also keep the AC generated voltage in phase with the system voltage at the STATCOM connection bus to generate or

absorb reactive power only (except for small active power required by transformer and inverter losses).

The control system uses the following modules:

- PLL (phase locked loop) synchronizes GTO pulses to the system voltage and provides a reference angle to the measurement system.
- Measurement System computes the positive-sequence components of the STATCOM voltage and current, using phase-to-dq transformation and a running-window averaging.
- Voltage regulation is performed by two PI regulators: from the measured voltage V_{meas} and the reference voltage V_{ref} , the Voltage Regulator block (outer loop) computes the reactive current reference I_{qref} used by the Current Regulator block (inner loop). The output of the current regulator is the α angle which is the phase shift of the inverter voltage with respect to the system voltage. This angle stays very close to zero except during short periods of time, as explained below.

A voltage droop is incorporated in the voltage regulation to obtain a V-I characteristics with a slope (0.03 p.u./100 MVA in this case). Therefore, when the STATCOM operating point changes from fully capacitive (+100 Mvar) to fully inductive (-100 Mvar) the SVC voltage varies between $1-0.03=0.97$ p.u. and $1+0.03=1.03$ p.u.

- Firing Pulses Generator generates pulses for the four inverters from the PLL output ($\omega.t$) and the current regulator output (α angle).

To explain the regulation principle, let us suppose that the system voltage V_{meas} becomes lower than the reference voltage V_{ref} . The voltage regulator will then ask for a higher reactive current output (positive I_q = capacitive current). To generate more capacitive reactive power, the current regulator will then increase α phase lag of inverter voltage with respect to system voltage, so that an active power will temporarily flow from AC system to capacitors, thus increasing DC voltage and consequently generating a higher AC voltage.

As explained in the preceding section, the conduction angle σ of the 3-level inverters has been fixed to 172.5° . This conduction angle minimizes 23rd and 25th harmonics of voltage generated by the square-wave inverters. Also, to reduce noncharacteristic harmonics, the positive and negative voltages of the DC bus are forced to stay equal by the DC Balance Regulator module. This is

performed by applying a slight offset on the conduction angles σ for the positive and negative half-cycles.

The STATCOM control system also allows selection of Var control mode (see the **STATCOM Controller** dialog box). In such a case, the reference current I_{qref} is no longer generated by the voltage regulator. It is rather determined from the Q_{ref} or I_{qref} references specified in the dialog box.

Steady State and Dynamic Performance of the STATCOM

You will now observe steady state waveforms and the STATCOM dynamic response when the system voltage is varied. Open the programmable voltage source menu and look at the sequence of voltage steps that are programmed. Also, open the **STATCOM Controller** dialog box and verify that the STATCOM is in Voltage regulation mode with a reference voltage of 1.0 p.u. Run the simulation and observe waveforms on the STATCOM scope block. These waveforms are reproduced below.

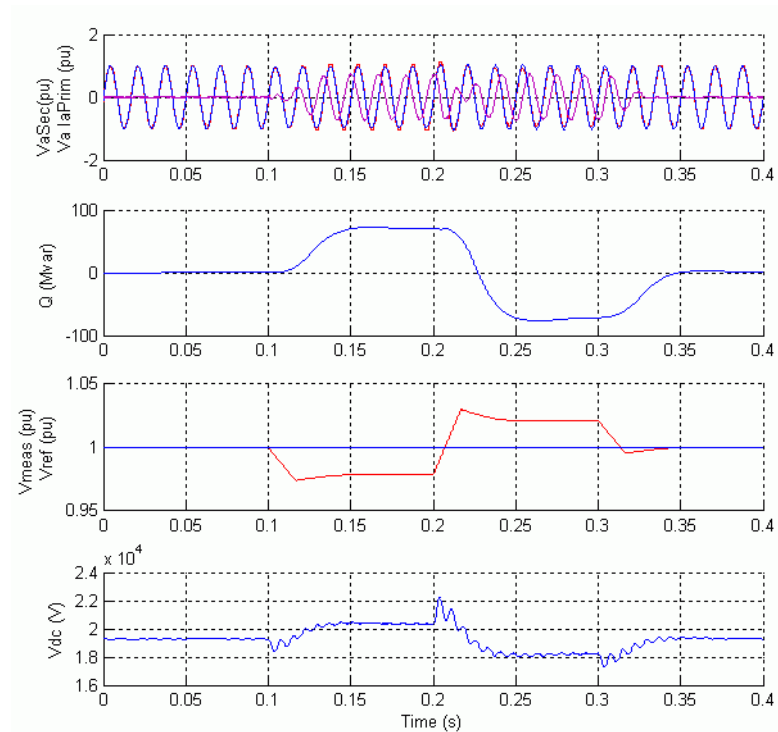

Waveforms Illustrating STATCOM Dynamic Response to System Voltage Steps

Initially the programmable voltage source is set at 1.0491 p.u., resulting in a 1.0 p.u. voltage at bus B1 when the STATCOM is out of service. As the reference voltage V_{ref} is set to 1.0 p.u., the STATCOM is initially floating (zero current). The DC voltage is 19.3 kV. At $t=0.1s$, voltage is suddenly decreased by 4.5% (0.955 p.u. of nominal voltage). The STATCOM reacts by generating reactive power ($Q=+70$ Mvar) to keep voltage at 0.979 p.u. The 95% settling time is approximately 47 ms. At this point the DC voltage has increased to 20.4 kV.

Then, at $t=0.2 s$ the source voltage is increased to 1.045 p.u. of its nominal value. The STATCOM reacts by changing its operating point from capacitive to inductive to keep voltage at 1.021 p.u. At this point the STATCOM absorbs 72 Mvar and the DC voltage has been lowered to 18.2 kV. Observe on the first

trace showing the STATCOM primary voltage and current that the current is changing from capacitive to inductive in approximately one cycle.

Finally, at $t=0.3$ s the source voltage is set back to its nominal value and the STATCOM operating point comes back to zero Mvar.

The figure below zooms on two cycles during steady state operation when the STATCOM is capacitive and when it is inductive. Waveforms show primary and secondary voltage (phase A) as well as primary current flowing into the STATCOM.

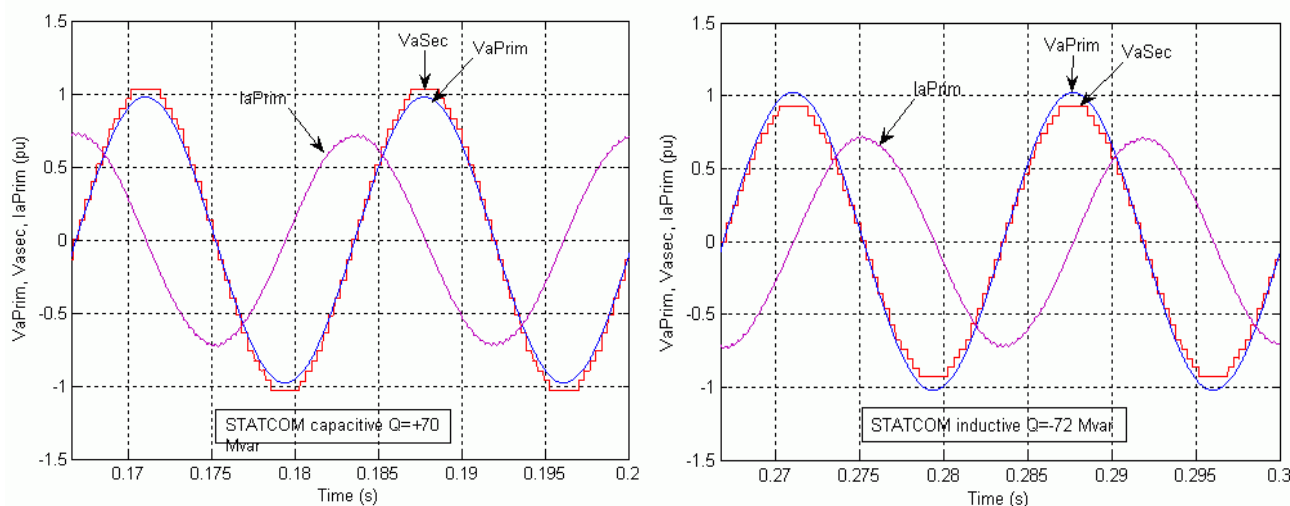

Steady State Voltages and Current for Capacitive and Inductive Operation

Notice that when the STATCOM is operating in capacitive mode ($Q=+70$ Mvar), the 48-pulse secondary voltage (in pu) generated by inverters is higher than the primary voltage (in p.u.) and in phase with primary voltage. Current is leading voltage by 90° ; the STATCOM is therefore generating reactive power.

On the contrary, when the STATCOM is operating in inductive mode, secondary voltage is lower than primary voltage. Current is lagging voltage by 90° ; the STATCOM is therefore absorbing reactive power.

Finally, if you look inside the Signals and Scopes subsystem you will have access to other control signals. Notice the transient changes on α angle when the DC voltage is increased or decreased to vary reactive power. The steady state value of α (0.5 degrees) is the phase shift required to maintain a small active power flow compensating transformer and converter losses.

Thyristor-Based HVDC Link

The example in this section illustrates modeling of a high-voltage direct current (HVDC) transmission link using 12-pulse thyristor converters [1]. Perturbations are applied to examine the system performance. The objectives of this example are to demonstrate the use of SimPowerSystems blocks in combination with Simulink blocks in the simulation of a complete pole of a 12-pulse HVDC transmission system. The Discrete HVDC Controller block is a generic control available in the Discrete Control Blocks library of the SimPowerSystems Extras library. In the same library you can find the Discrete Gamma Measurement block used in the inverter control subsystem.

Description of the HVDC Transmission System

Open the `power_hvdc12pulse` model and save it as `case4.mdl` to allow further modifications to the original system. This system is shown in Figure 5-9.

A 1000 MW (500 kV, 2 kA) DC interconnection is used to transmit power from a 500 kV, 5000 MVA, 60 Hz system to a 345 kV, 10000 MVA, 50 Hz system. The AC systems are represented by damped L-R equivalents with an angle of 80 degrees at fundamental frequency (60 Hz or 50 Hz) and at the third harmonic.

The rectifier and the inverter are 12-pulse converters using two Universal Bridge blocks connected in series. Open the two converter subsystems (Rectifier block and Inverter block) to see how they are built. The converters are interconnected through a 300-km line and 0.5 H smoothing reactors. The converter transformers (Wye grounded/Wye/Delta) are modeled with Three-Phase Transformer (Three-Windings) blocks. The transformer tap changers are not simulated. The tap position is rather at a fixed position determined by a multiplication factor applied to the primary nominal voltage of the converter transformers (0.90 on the rectifier side; 0.96 on the inverter side).

From the AC point of view, an HVDC converter acts as a source of harmonic currents. From the DC point of view, it is a source of harmonic voltages.

The order n of these characteristic harmonics is related to the pulse number p of the converter configuration: $n = kp \pm 1$ for the AC current and $n = kp$ for the direct voltage, k being any integer. In the example, $p = 12$, so that injected harmonics on the AC side are 11, 13, 23, 25, and on the DC side are 12, 24.

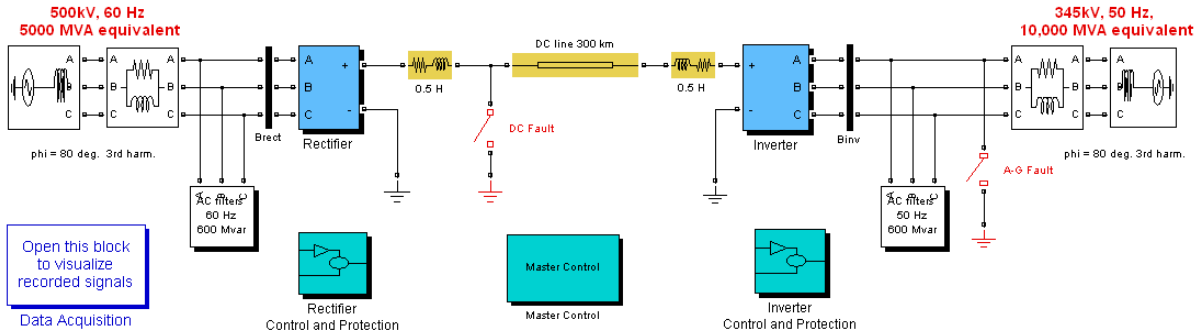

Figure 5-9: HVDC System

AC filters are used to prevent the odd harmonic currents from spreading out on the AC system. The filters are grouped in two subsystems. These filters also appear as large capacitors at fundamental frequency, thus providing reactive power compensation for the rectifier consumption due to the firing angle α . For $\alpha = 30$ degrees, the converter reactive power demand is approximately 60% of the power transmitted at full load. Look inside the AC filters subsystem to see the high Q (100) tuned filters at the 11th and 13th harmonics and the low Q (3), or damped filter, used to eliminate the higher order harmonics, e.g., 24th and up. Extra reactive power is also provided by capacitor banks.

Two circuit breakers are used to apply faults: one on the rectifier DC side and the other on the inverter AC side.

The rectifier and inverter control and protection systems use the new updated Discrete HVDC Controller block in the Discrete Control Blocks library of the SimPowerSystems Extras library.

The power system and the control and protection system are both discretized with the same sample time $T_s = 50\mu s$. Some protection systems have a sample time of 1 or 2 ms.

Frequency Response of the AC and DC Systems

You now measure the frequency response of the AC systems (rectifier and inverter sides) and of the DC line.

The section “Analyzing a Simple Circuit” on page 1-16 explains how the Impedance Measurement block allows you to compute the impedance of a linear system from its state-space model. As the thyristor valves of the converters are nonlinear blocks, they are ignored in the impedance calculation and you get the impedances with the valves open.

Open the Measurements library, copy three Impedance Measurement blocks into your model, and rename them *Zrec*, *Zinv*, and *ZDC*. Connect the two inputs of *Zrec* and *Zinv* between phase A and phase B of the AC system on the rectifier and inverter sides. Measuring the impedance between two phases gives two times the positive-sequence impedance. Therefore you must apply a factor of 1/2 to the impedance to obtain the correct impedance value. Open the two Impedance Measurement blocks and set the **Multiplication factor** to 0.5. Finally, connect input 1 of the *ZDC* block between the DC line terminal and the rectifier smoothing reactor, and connect input 2 to ground. Save your modified model as *case4Zf.mdl*.

In the Powergui, select **Impedance vs Frequency Measurement**. A new window opens, showing the three Impedance Measurement block names. Fill in the **Frequency range** by entering 10:2:1500. Select the *lin* scale to display the *Z* magnitude and *lin* scale for the frequency axis. Click the **Save data to workspace** button and enter *Zcase4* as the variable name to contain the impedance vs. frequency. Click the **Display** button.

When the calculation is finished, the magnitude and phase as functions of frequency measured by the three Impedance Measurement blocks are displayed in the window. Your workspace should have a variable named *Zcase5*. It is a four-column matrix containing frequency in column 1 and the three complex impedances in columns 2, 3, and 4 with the same order as in the window displaying the block names.

The magnitudes of the three impedances as a function of frequency are shown here.

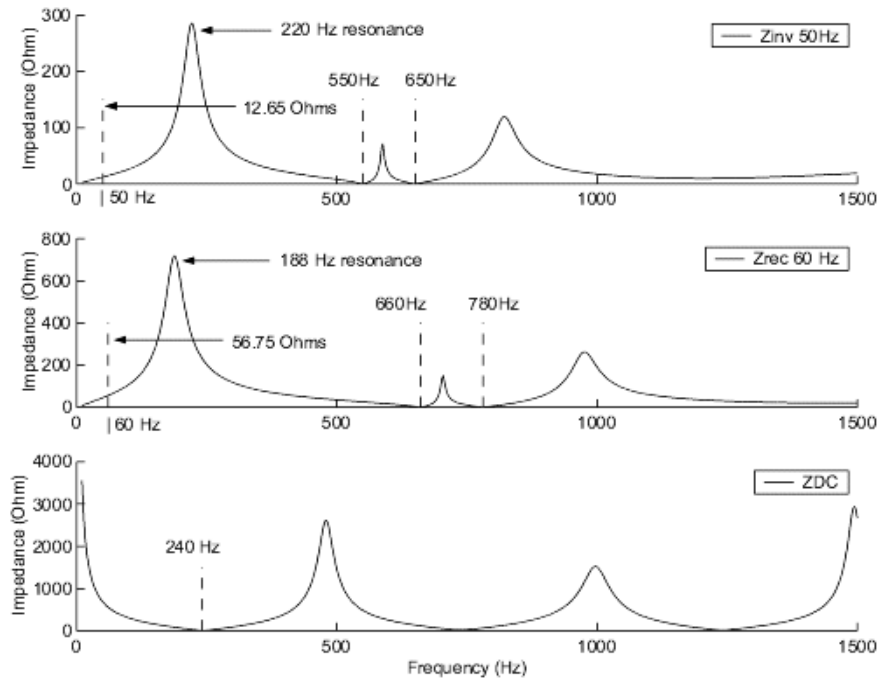

Positive-Sequence Impedances of the Two AC Systems and of the DC Line

Note the two minimum impedances on the Z magnitudes of the AC systems. These series resonances are created by the 11th and 13th harmonic filters. They occur at 660 Hz and 780 Hz on the 60 Hz system. Note also that the addition of 600 Mvar capacitive filters on the inductive systems creates resonances (around 188 Hz on the rectifier side and 220 Hz on the inverter side). Zoom in on the impedance magnitude in the 60 Hz region. You should find a magnitude of 56.75Ω for the 60 Hz system, corresponding to an effective short-circuit level of $500^2/56.75 = 4405$ MVA on the rectifier side (5000 MVA - 600 Mvar of filters).

For the DC line, note the series resonance at 240 Hz, which corresponds to the main mode likely to be excited on the DC side, under large disturbances.

Description of the Control and Protection Systems

The control systems of the rectifier and of the inverter use the same Discrete HVDC Controller block from the Discrete Control Blocks library of the SimPowerSystems Extras library. The block can operate in either rectifier or inverter mode. At the inverter, the Gamma Measurement block is used and it is found in the same library. Use **Look under mask** to see how these blocks are built.

The Master Control system generates the current reference for both converters and initiates the starting and stopping of the DC power transmission.

The protection systems can be switched on and off. At the rectifier, the DC fault protection detects a fault on the line and takes the necessary action to clear the fault. The Low AC Voltage Detection subsystem at the rectifier and inverter serves to discriminate between an AC fault and a DC fault. At the inverter, the Commutation Failure Prevention Control subsystem [2] mitigates commutation failures due to AC voltage dips. A more detailed description is given in each of these protection blocks.

HVDC Controller Block Inputs and Outputs

Inputs 1 and 2 are the DC line voltage (V_{dL}) and current (I_d). Note that the measured DC currents (I_{d_R} and I_{d_I} in A) and DC voltages (V_{dL_R} and V_{dL_I} in V) are scaled to p.u. (1 p.u. current = 2 kA; 1 p.u. voltage = 500 kV) before they are used in the controllers. The V_{dL} and I_d inputs are filtered before being processed by the regulators. A first-order filter is used on the I_d input and a second-order filter is used on the V_{dL} input.

Inputs 3 and 4 (I_{d_ref} and V_{d_ref}) are the V_d and I_d reference values in p.u.

Input 5 (Block) accepts a logical signal (0 or 1) used to block the converter when Block = 1.

Input 6 (Forced-alpha) is also a logical signal that can be used for protection purposes. If this signal is high (1), the firing angle is forced at the value defined in the block dialog box.

Input 7 (γ_{meas}) is the measured minimum extinction angle γ of the converter 12 valves. It is obtained by combining the outputs of two 6-pulse Gamma Measurement blocks. Input 8 (γ_{ref}) is the extinction angle γ reference in degrees. To minimize the reactive power absorption, the reference is set to a minimum acceptable angle (e.g., 18 deg).

Finally, input 9 (D_{α}) is a value that is subtracted from the α delay angle maximum limit to increase the commutation margin during transients.

The first output (α_{ord}) is the firing delay angle α in degrees ordered by the regulator. The second output ($I_{d_ref_lim}$) is the actual reference current value (value of I_{d_ref} limited by the $VDCOL$ function as explained below). The third output ($Mode$) is an indication of the actual state of the converter control mode. The state is given by a number (from 0 to 6) as follows:

0	Blocked pulses
1	Current control
2	Voltage control
3	Alpha minimum limitation
4	Alpha maximum limitation
5	Forced or constant alpha
6	Gamma control

Synchronization and Firing System

The synchronization and generation of the twelve firing pulses is performed in the 12-Pulse Firing Control system. Use **Look under mask** to see how this block is built. This block uses the primary voltages (input 2) to synchronize and generate the pulses according to the alpha firing angle computed by converter controller (input 1). The synchronizing voltages are measured at the primary side of the converter transformer because the waveforms are less distorted. A Phase Locked Loop (PLL) is used to generate three voltages synchronized on the fundamental component of the positive-sequence voltages. The firing pulse generator is synchronized to the three voltages generated by the PLL. At the zero crossings of the commutating voltages (AB, BC, CA), a ramp is reset. A firing pulse is generated whenever the ramp value becomes equal to the desired delay angle provided by the controller.

Steady-State V-I Characteristic

The Discrete HVDC Controller block implements this steady-state characteristic:

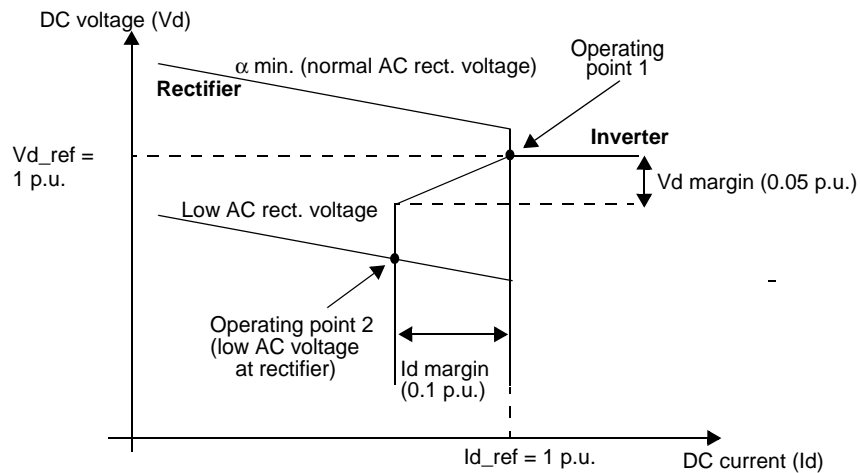

Rectifier and Inverter Steady-State Characteristics and VDCOL Function

In normal operation, the rectifier controls the current at the I_{d_ref} reference value, whereas the inverter controls the voltage or gamma at the V_{d_ref} or Γ_{min} reference value. The I_{d_margin} , V_{d_margin} , or Γ_{margin} parameters are defined in the inverter dialog box. They are set at 0.1 p.u., 0.05 p.u., and 1.0 deg., respectively.

The system normally operates at point 1 as shown in the figure. However, during a severe contingency producing a voltage drop on the AC system 1 feeding the rectifier, the operating point moves to point 2. The rectifier, therefore, is forced to a minimum α mode and the inverter is in current control mode. Similarly, a voltage drop on the AC system feeding the inverter will force a control mode change to Gamma regulation to limit the angle to γ_{min} . During severe contingency, a faster response is necessary to increase the commutation margin and consequently to reduce the probability of a commutation failure. The Commutation Failure Prevention Control subsystem (look under the Inverter protections block) generates a signal that decreases the maximum limit of the delay angle during the voltage drop (e.g., during an AC fault).

Note $\gamma = \text{extinction angle} = 180^\circ - \alpha - \mu$, $\mu = \text{commutation or overlap angle}$

VDCOL Function

Another important control function is implemented to change the reference current according to the value of the DC voltage. This control, named Voltage Dependent Current Order Limiter (VDCOL), automatically reduces the reference current (I_{d_ref}) set point when V_{dL} decreases (as, for example, during a DC line fault or a severe AC fault). Reducing the I_{d_ref} reference currents also reduces the reactive power demand on the AC system, helping to recover from fault. The VDCOL parameters of the Discrete HVDC Control block dialog box are explained by this diagram:

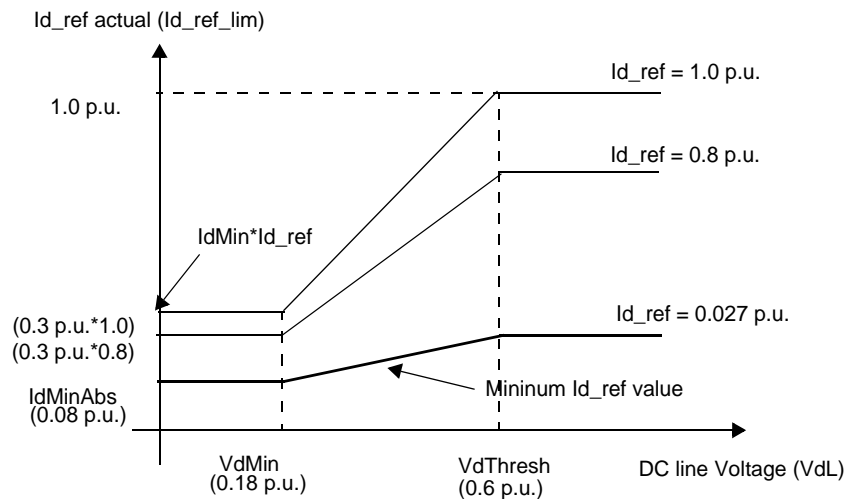

VDCOL Characteristic; $I_{d_ref} = f(V_{dL})$

The I_{d_ref} value starts to decrease when the V_d line voltage falls below a threshold value $V_{dThresh}$ (0.6 p.u.). The actual reference current used by the controllers is available at the second controller output, named $I_{d_ref_lim}$. $I_{dMinAbs}$ is the absolute minimum I_{d_ref} value, set at 0.08 p.u. When the DC line voltage falls below the $V_{dThresh}$ value, the VDCOL drops instantaneously to I_{d_ref} . However, when the DC voltage recovers, VDCOL limits the I_{d_ref} rise time with a time constant defined by parameter T_{up} (80 ms in the example).

Current, Voltage, and Gamma Regulators

Both rectifier and inverter controls have current regulator calculating firing α_i . At the inverter, operating in parallel with the current regulator are the voltage and/or gamma regulators calculating firing angles α_v and/or α_g . The effective α angle is the minimum value of α_i , α_v and/or α_g . This angle is available at the first block output, named `alpha_ord (deg)`. All regulators are of the proportional- integral type. They should have high enough gains for low frequencies (<10 Hz) to maintain the current, voltage, or gamma response equal to the reference current (`Id_ref_lim`), reference voltage (`Vd_ref`), or reference gamma (`Gamma_min`), as long as α is within the minimum and maximum limits ($5^\circ < \alpha < 166^\circ$ for rectifier, $92^\circ < \alpha < 166^\circ$ for inverter). As described before, a signal (`D_alpha`) received from the Commutation Failure Prevention protection can temporarily reduce the 166° limit at the inverter. The regulator gains `Kp` and `Ki` are adjusted during small perturbations in the reference. The following gains are used:

Current regulator	Kp = 45 deg/p.u.	Ki = 4500 deg/p.u./s
Voltage regulator	Kp = 35 deg/p.u.	Ki = 2250 deg/p.u./s
Gamma regulator	Kp = 1 deg/deg	Ki = 20 deg/deg/s

Another particularity of the regulator is the linearization of the proportional gain. As the `Vd` voltage generated by the rectifier and the inverter is proportional to $\cos(\alpha)$, the ΔVd variation due to a $\Delta\alpha$ change is proportional to $\sin(\alpha)$. With a constant `Kp` value, the effective gain is, therefore, proportional to $\sin(\alpha)$. To keep a constant proportional gain, independent of the α value, the gain is linearized by multiplying the `Kp` constant by $1/\sin(\alpha)$. This linearization is applied for a range of α defined by two limits specified in the dialog box.

System Startup/Stop – Steady State and Step Response

Notice that the system is discretized, using sample time `Ts = 50e-6 s`.

The system is programmed to start and reach a steady state. Then a step is applied first to the reference current and later to the voltage reference so you can observe the dynamic response of the regulators. Finally, a stop sequence is initiated to bring the power transmission smoothly down before blocking the converters. Notice in the Converter Controller that after reception of the Stop

signal a Forced_alpha is ordered for 0.150 s, and then 0.1 s later the blocking of the pulses is ordered.

Start the simulation and observe the signals on the Rectifier and Inverter scopes. The waveforms are reproduced here:

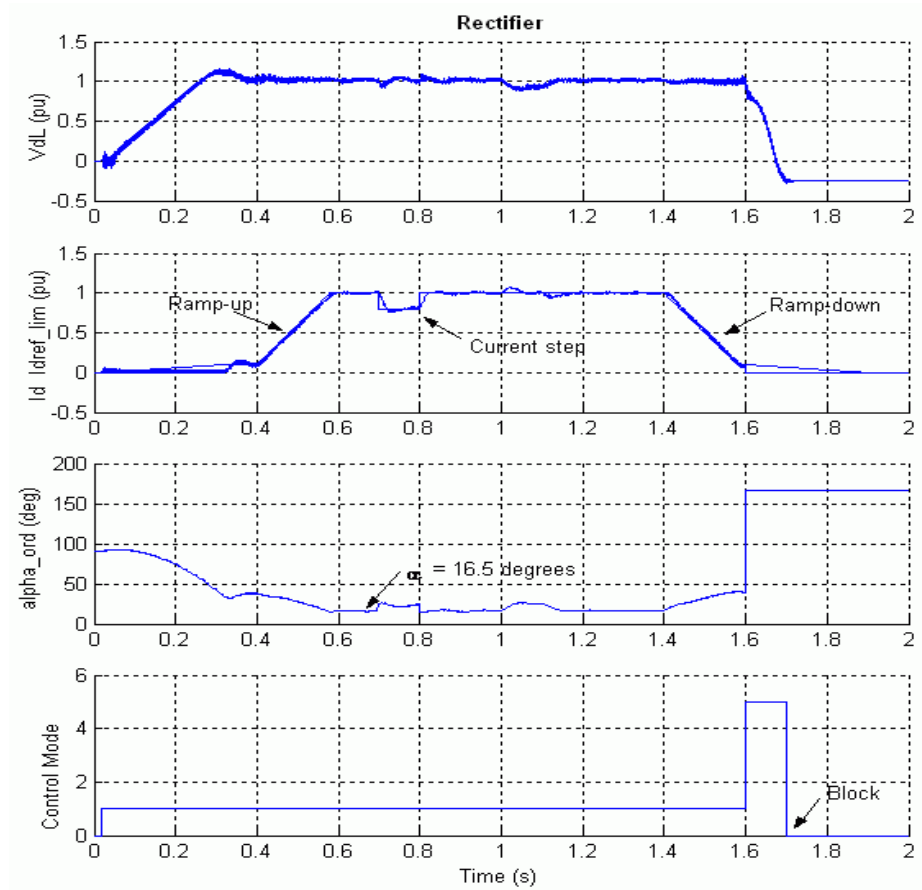

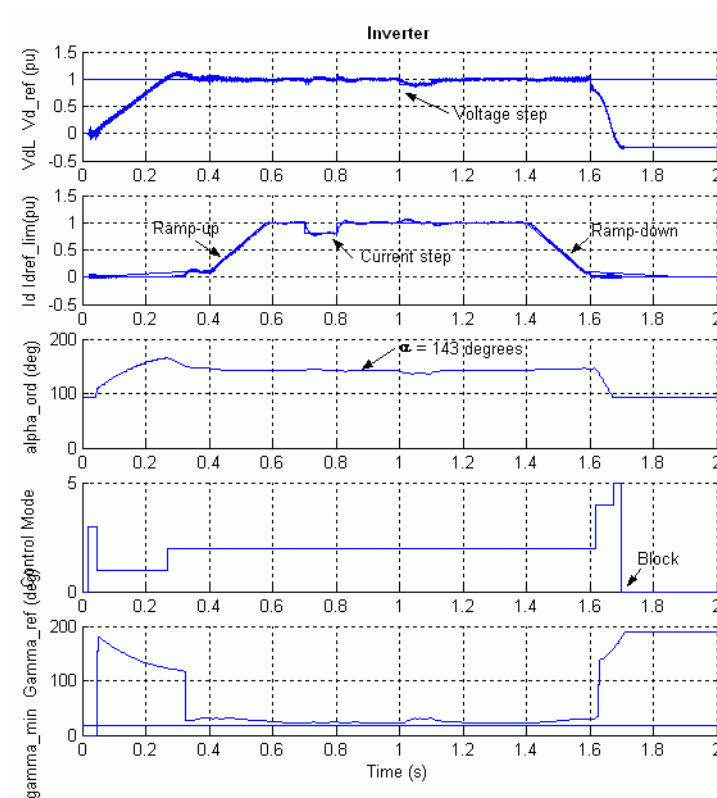

Figure 5-10: Startup/Stop of the DC System and Step Applied on the Current and Voltage Reference

In the Master Control, the converters pulse generators are deblocked and the power transmission started by ramping the reference current at $t = 20$ ms. The reference reaches the minimum value of 0.1 p.u. in 0.3 s. Observe that the DC current starts to build and the DC line is charged at its nominal voltage. At $t = 0.4$ s, the reference current is ramped from 0.1 to 1 p.u. (2 kA) in 0.18 s (5 p.u./s). The DC current reaches steady state at the end of the starting sequence at approximately 0.58 s. The rectifier controls the current and the inverter controls the voltage. Trace 1 of both Rectifier and Inverter scopes shows the DC line voltage (1 p.u. = 500 kV). At the inverter, the voltage reference is also shown. Trace 2 shows the reference current and the measured Id current (1

p.u. = 2 kA). During the ramp, the inverter is actually controlling the current (Trace 4: Mode = 1) to the value of $I_{d_ref_lim}$ less the Current Margin (0.1 p.u.) and the rectifier tries to control the current at $I_{d_ref_lim}$. At the inverter, the control mode changes to voltage control (Mode = 2) at $t = 0.3$ s and the rectifier becomes effectively in control of the current. At steady state (measured at t between 1.3 and 1.4 s), the α firing angles are around 16.5 degrees and 143 degrees respectively on the rectifier and inverter side. At the inverter, two Gamma Measurement blocks measure the extinction angle γ for each thyristor of the two six-pulse bridges (i.e., the bridge connected to the Wye and Delta windings) by determining the elapsed time expressed in electrical degrees from the end of current conduction to the zero crossing of the commutating voltage. The minimum of 12 γ values are shown in trace 5 along with Gamma reference. In steady state, the minimum γ is around 22 degrees.

At $t = 0.7$ s, a -0.2 p.u. step is applied during 0.1 s to the reference current so that you can observe the dynamic response of the regulators. Later on, at $t = 1.0$ s, a -0.1 p.u. step is applied during 0.1 s at the inverter reference voltage. Observe that at the inverter the extinction angle remains greater than the reference value (e.g., the minimum acceptable value) and that the Gamma regulator never took control since α_v stayed smaller than α_g .

At $t = 1.4$ s the Stop sequence is initiated by ramping down the current to 0.1 pu. At $t = 1.6$ s a Forced-alpha (to 166 deg) at the rectifier extinguishes the current and at the inverter the Forced-alpha (to 92 deg with a limited rate) brings down the DC voltage due to the trapped charge in the line capacitance. At $t = 1.7$ s the pulses are blocked in both converters.

Comparison of Theory and Simulation Results in Steady State

The main equations governing the steady-state operation of the DC system are given here so that you can compare the theoretical values to the simulation results.

The following expression relates the mean direct voltage V_d of a 12-pulse bridge to the direct current I_d and firing angle α (neglecting the ohmic losses in the transformer and thyristors):

$$V_d = 2 \times (V_{do} \times \cos(\alpha) - R_c \times I_d)$$

where V_{do} is the ideal no-load direct voltage for a six-pulse bridge:

$$V_{do} = (3\sqrt{2}/\pi) \times V_c$$

V_c is the line-to-line RMS commutating voltage that is dependent on the AC system voltage and the transformer ratio.

R_c is the equivalent commutating resistance.

$$R_c = (3/\pi) \times X_c$$

X_c is the commutating reactance or transformer reactance referred to the valve side.

The following rectifier parameters were used in the simulation.

The V_c voltage must take into account the effective value of the voltage on the 500 kV bus and the transformer ratio. If you look at the waveforms displayed on the AC_Rectifier scope, you find 0.96 p.u. when the direct current I_d has reached its steady state (1 p.u.).

If you open the rectifier transformer dialog box, you find a multiplication factor of 0.90 applied to the primary nominal voltage. The voltage applied to the inverter is therefore boosted by a factor of 1/0.90.

$$V_c = 0.96 * 200 \text{ kV} / 0.90 = 213.3 \text{ kV}$$

$$I_d = 2 \text{ kA}$$

$$\alpha = 16.5^\circ$$

$$X_c = 0.24 \text{ p.u.}, \text{ based on } 1200 \text{ MVA and } 222.2 \text{ kV} = 9.874 \Omega$$

Therefore, this theoretical voltage corresponds well with the expected rectifier voltage calculated from the inverter voltage and the voltage drop in the DC line ($R = 4.5 \Omega$) and in the rectifier smoothing reactor ($R = 1 \Omega$):

$$V_d = V_{dL_{inverter}} + (R_{DCline} + R_{inductance}) \times I_d$$

$$V_d = 500 \text{ kV} + (4.5\Omega + 1\Omega) \times 2 = 511 \text{ kV}$$

The μ commutation or overlap angle can also be calculated. Its theoretical value depends on α , the DC current I_d , and the commutation reactance X_c .

$$V_{do} = (3\sqrt{2}/\pi) \times 213.3 = 288.1 \text{ kV}$$

$$R_c = (3/\pi) \times 9.874 = 9.429 \ \Omega$$

$$V_d = 2 \times (288.1 \text{ kV} \times \cos(16.5^\circ) - 9.429 \times 2) = 515 \text{ kV}$$

$$\mu = \arccos \left[\cos(\alpha) - \frac{X_c \cdot I_d \cdot \sqrt{2}}{V_c} \right] - \alpha$$

$$\mu = \arccos \left[\cos(16.5^\circ) - \frac{9.874 \cdot 2 \cdot \sqrt{2}}{213.3} \right] - 16.5^\circ = 17.6^\circ$$

Now verify the commutation angle by observing the currents in two valves, for example, current extinction in valve 1 and current buildup in valve 3 of the Y six-pulse bridge of the rectifier. These signals are available in the VALVE13_RECT scope.

The waveforms illustrating two cycles are shown in the following figure. The measured commutation angle is 14 steps of $50 \mu\text{s}$ or 15.1° of a 60 Hz period. The resolution with a $50 \mu\text{s}$ time step is 1.1° ; this angle compares reasonably well with the theoretical value.

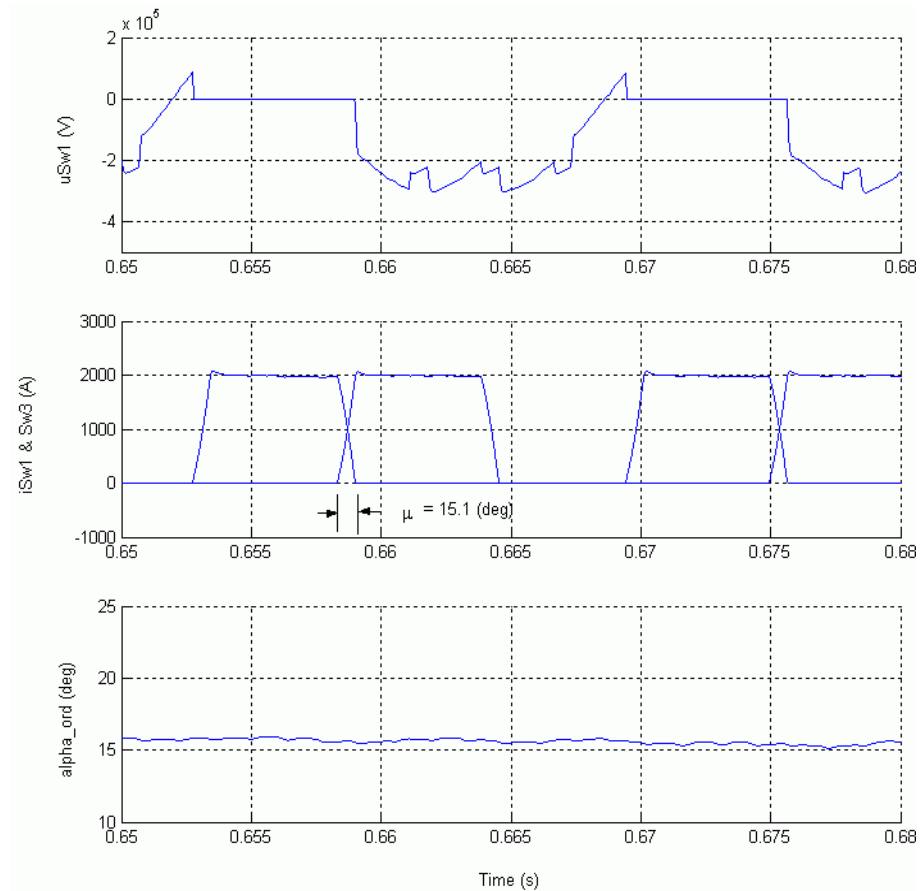

Figure 5-11: Valve Voltage and Currents (Commutation from Valve 1 to Valve 3)

Finally, to validate the γ measurement at the inverter, observe the valve 1 voltage and current in the VALVE1_INV scope. Also observe the commutating voltage corresponding to the outgoing valve 1 to be extinguished and the mean value of γ as shown in Figure 5-12. Verify also that the values of α , μ , and γ add up to 180° .

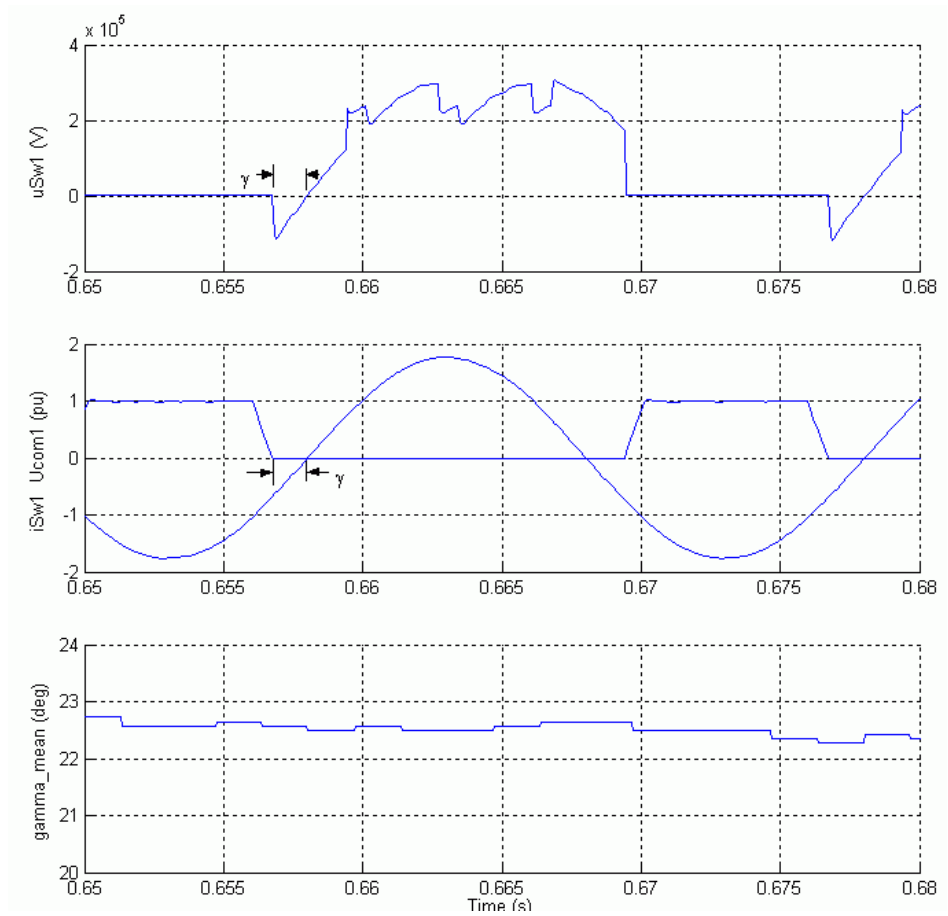
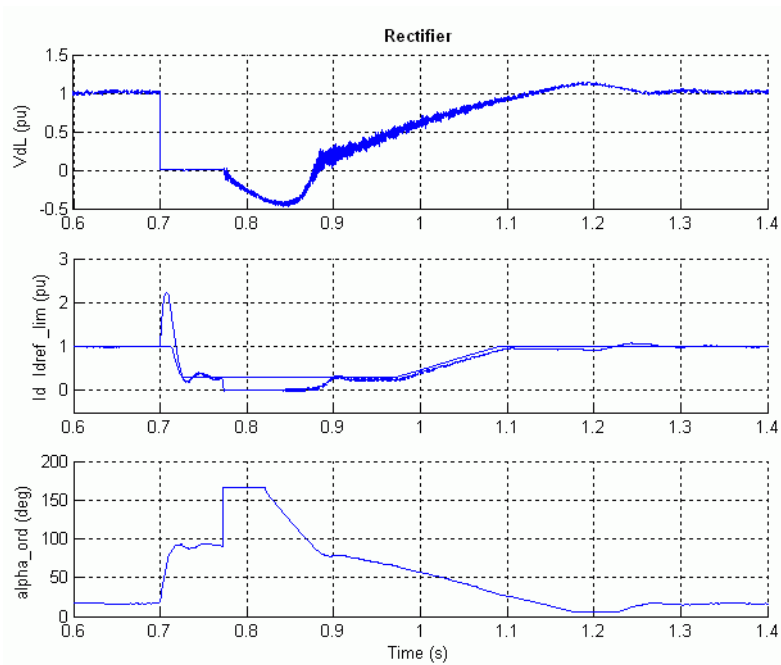

Figure 5-12: Current and Commutation Voltage of Valve 1 Showing γ

DC Line Fault

Deactivate the steps applied on the current reference and on the voltage reference in the Master Control and in the Inverter Control and Protection respectively by setting the switches in lower position. In the DC Fault block, change the multiplication factor of 100 to 1, so that a fault is now applied at $t = 0.7$ s. Reduce the Simulation Stop time to 1.4 s. Open the Rectifier scope as

well as the Fault scope to observe the fault current and the Protection Rectifier scope to observe the DC Fault protection action. Restart the simulation.



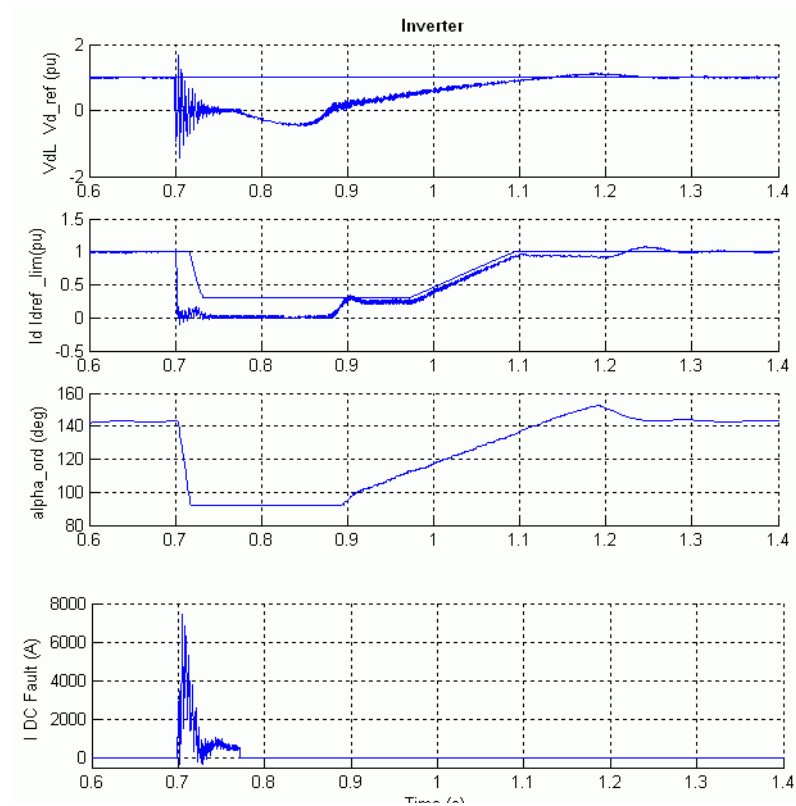

Figure 5-13: DC Line Fault on the Rectifier Side

At fault application ($t = 0.7$ s), the DC current increases to 2.2 p.u. and the DC voltage falls to zero at the rectifier. This DC voltage drop is seen by the Voltage Dependent Current Order Limiter (VDCOL) and the DC Fault protection. The VDCOL reduces the reference current to 0.3 p.u. at the rectifier. A DC current still continues to circulate in the fault. Then, at $t = 0.77$ s, the rectifier α firing angle is forced to 166 degrees by the DC Fault protection after detecting a low DC voltage. The rectifier now operates in inverter mode. The DC line voltage becomes negative and the energy stored in the line is returned to the AC system, causing rapid extinction of the fault current at its next zero crossing. Then α is released at $t = 0.82$ s and the normal DC voltage and current recover

in approximately 0.5 s. Notice, the temporary mode change in the Rectifier controls between 1.18 s and 1.25 s.

AC Line-to-Ground Fault at the Inverter

Now modify the fault timings to apply a line-to-ground fault. In the DC Fault block, change the multiplication factor of 1 to 100, so that the DC fault is now eliminated. In the A-G Fault block, change the multiplication factor in the switching times to 1, so that a six-cycle line-to-ground fault is now applied at $t = 0.7$ s at the inverter. Restart the simulation.

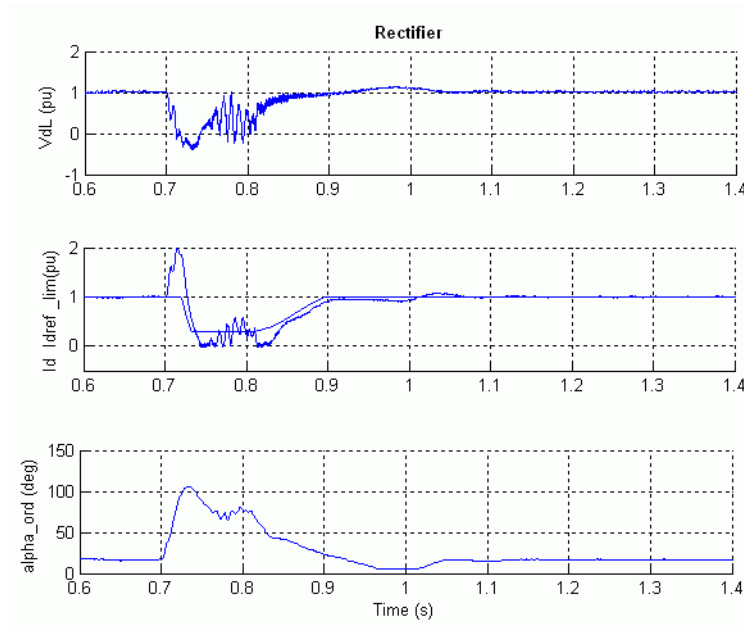

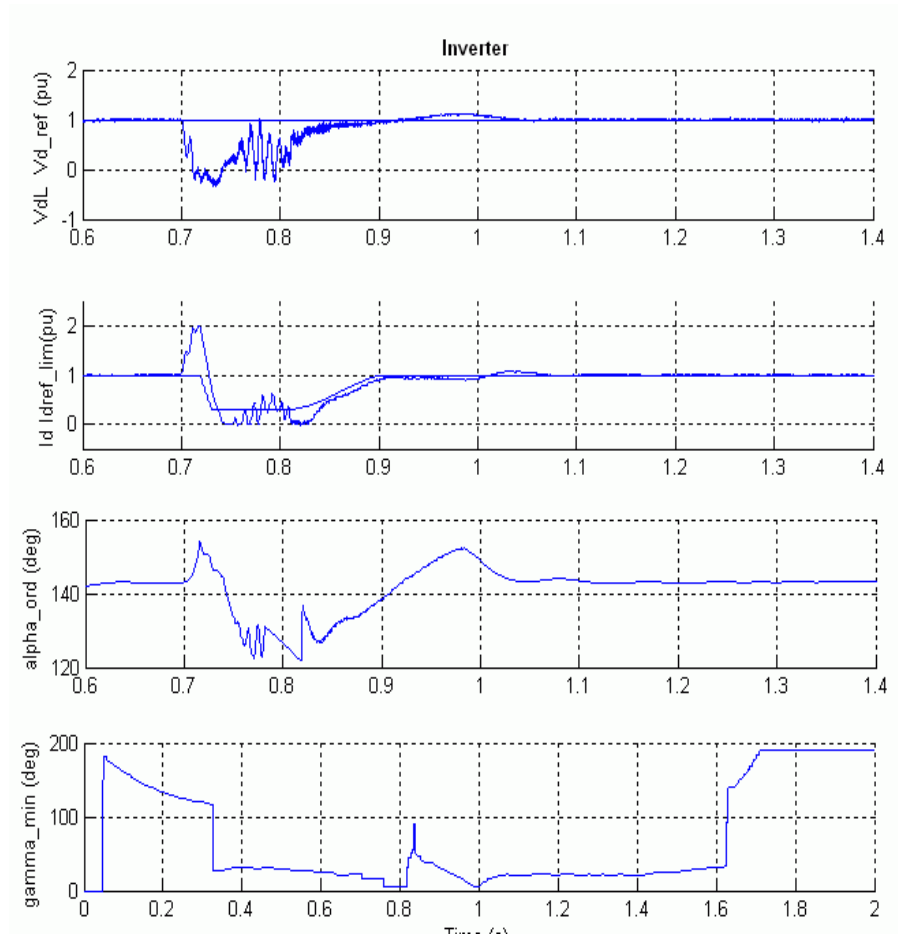

Figure 5-14: Rectifier, Inverter Signals for an AC Line Fault on Inverter Side

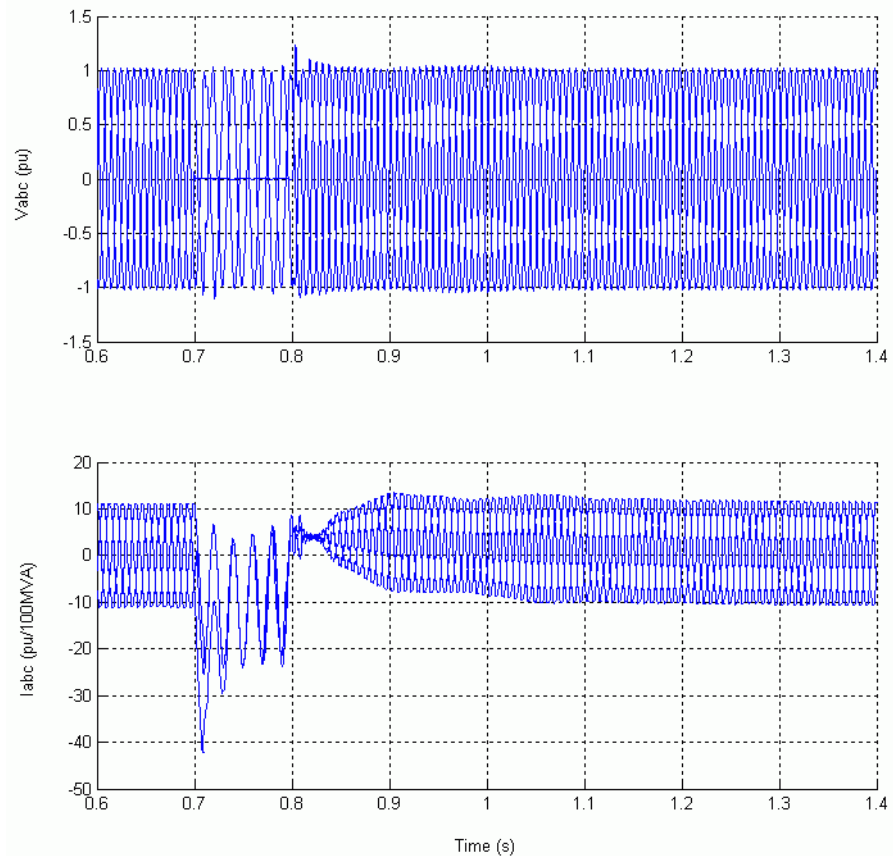

Figure 5-15: Voltages and Currents on the 50 Hz Side for an AC Line Fault on the Inverter Side

Notice the 120 Hz oscillations in the DC voltage and currents during the fault. An unavoidable commutation failure occurs at the inverter at the very beginning of the fault and the DC current increases to 2 p.u. When the fault is cleared at $t = 0.8$ s, the VDCOL operates and reduces the reference current to 0.3 p.u. The system recovers in approximately 0.35 s after fault clearing.

Look at the waveforms displayed on the PROTECTION INVERTER scope. The Low AC Voltage block detects the fault and locks the DC Fault protection that in this case should not detect a DC fault even if the DC line voltage dips. Look at the Commutation Failure Prevention Control (CFPREV) output (A_min_I) which decreases the maximum delay angle limit to increase the commutation margin during and after the fault.

Now open the dialog box of the CFPREV block located inside the Inverter Protections subsystem and deactivate the CFPREV protection by deselecting the “ON State.” Restart the simulation. Note that a second commutation failure now occurs during the fault (at t around 0.775 s). A commutation failure is the result of a failure of the incoming valve to take over the direct current before the commutation voltage reverses its polarity. The symptoms are a zero DC voltage across the affected bridge causing an increase of the DC current at a rate determined mainly by the DC circuit inductance.

References

- [1] Arrilaga, J., *High Voltage Direct Current Transmission*, IEEE Power Engineering Series 6, Peter Peregrinus, Ltd., 1983.
- [2] Lidong Zhang, Lars Dofnas, “A Novel Method to Mitigate Commutation Failures in HVDC Systems,” *Proceedings PowerCon 2002. International Conference on*, Volume: 1, 13-17 Oct. 2002, pp. 51 -56.

VSC-Based HVDC Link

The increasing rating and improved performance of self-commutated semiconductor devices have made possible High Voltage DC (HVDC) transmission based on Voltage Sourced Converter (VSC). Two technologies offered by the manufacturers are the HVDC Light [1] and the HVDC^{plus} [2].

The example described in this section illustrates modeling of a forced-commutated Voltage- Sourced Converter high-voltage direct current (VSC-HVDC) transmission link. The objectives of this example are to demonstrate the use of SimPowerSystems blocks in the simulation of a HVDC transmission link based on three-level Neutral Point Clamped (NPC) VSC converters with single-phase carrier based Sinusoidal Pulse Width Modulation (SPWM) switching. Perturbations are applied to examine the system dynamic performance.

Description of the HVDC Link

The principal characteristic of VSC-HVDC transmission is its ability to independently control the reactive and real power flow at each of the AC systems to which it is connected, at the Point of Common Coupling (PCC). In contrast to line-commutated HVDC transmission, the polarity of the DC link voltage remains the same with the DC current being reversed to change the direction of power flow.

The HVDC link described in this example is available in the `power_hvdc_vsc` model. You can run the command by entering the following in the MATLAB Command Window: `power_hvdc_vsc`. Load this model and save it in your working directory as `case5.mdl` to allow further modifications to the original system. This model shown on Figure 5-16 represents a 200 MVA, +/- 100 kV VSC-HVDC transmission link.

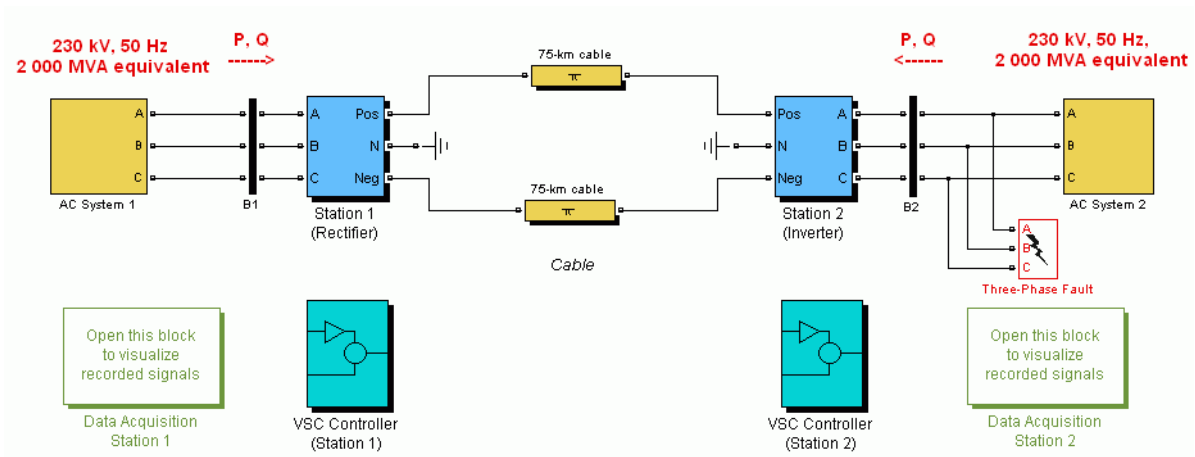

Figure 5-16: VSC-HVDC Transmission System Model

The 230 kV, 2000 MVA AC systems (AC system1 and AC system2 subsystems) are modeled by damped L-R equivalents with an angle of 80 degrees at fundamental frequency (50 Hz) and at the third harmonic. The VSC converters are three-level bridge blocks using close to ideal switching device model of IGBT/diodes. The relative ease with which the IGBT can be controlled and its suitability for high-frequency switching, has made this device the better choice over GTO and thyristors. Open the Station 1 and Station 2 subsystems to see how they are built.

A converter transformer (Wye grounded /Delta) is used to permit the optimal voltage transformation. The present winding arrangement blocks triplen harmonics produced by the converter. The transformer tap changer or saturation are not simulated. The tap position is rather at a fixed position determined by a multiplication factor applied to the primary nominal voltage of the converter transformers. The multiplication factors are chosen to have a modulation index around 0.85 (transformer ratios of 0.915 on the rectifier side and 1.015 on the inverter side). The converter reactor and the transformer leakage reactance permit the VSC output voltage to shift in phase and amplitude with respect to the AC system, and allows control of converter active and reactive power output.

To meet AC system harmonic specifications, AC filters form an essential part of the scheme. They can be connected as shunt elements on the AC system side or the converter side of the converter transformer. Since there are only high frequency harmonics, shunt filtering is therefore relatively small compared to the converter rating. It is sufficient with a high pass-filter and no tuned filters are needed. The later arrangement is used in our model and a converter reactor, an air cored device, separates the fundamental frequency (filter bus) from the raw PWM waveform (converter bus). The AC harmonics generation [4] mainly depends on the:

- Type of modulation (e.g. single-phase or three-phase carrier based, space vector, etc.)
- Frequency index $p = \text{carrier frequency} / \text{modulator frequency}$ (e.g. $p = 1350/50 = 27$)
- Modulation index $m = \text{fundamental output voltage of the converter} / \text{pole to pole DC voltage}$

The principal harmonic voltages are generated at and around multiples of p . The shunt AC filters are 27th and 54th high pass totaling 40 Mvar. To illustrate the AC filter action we did an FFT analysis in steady-state of the converter phase A voltage and the filter bus phase A voltage, using the Powergui block. The results are shown in Figure 5-17.

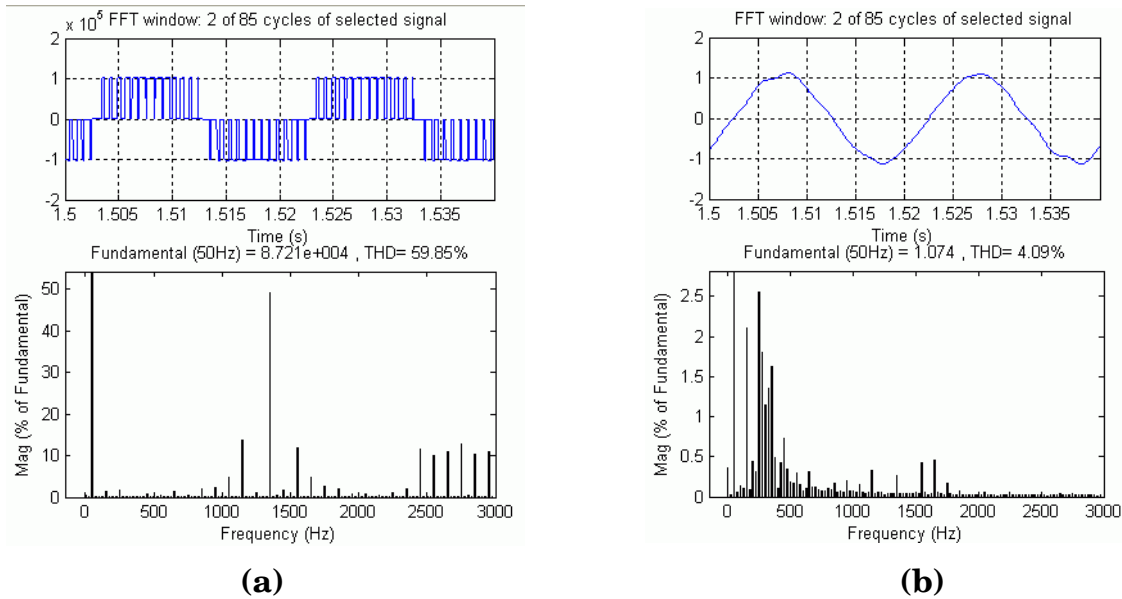

Figure 5-17: Phase A Voltage and FFT Analysis. (a) Converter Bus (b) Filter Bus

The reservoir DC capacitors are connected to the VSC terminals. They have an influence on the system dynamics and the voltage ripple on the DC side. The size of the capacitor is defined by the time constant τ corresponding to the time it takes to charge the capacitor to the base voltage (100 kV) if it is charged with the base current (1 kA). This yields

$$\tau = C \cdot Z_{\text{base}} = 70\text{e-}6 \cdot 100 = 7 \text{ ms}$$

with $Z_{\text{base}} = 100\text{kV}/1 \text{ kA}$

The DC side filters blocking high-frequency are tuned to the 3rd harmonic, i.e. the main harmonic present in the positive and negative pole voltages. It is shown that a reactive converter current generate a relatively large third harmonic in both the positive and negative pole voltages [3] but not in the total DC voltage. The DC harmonics can also be zero-sequence harmonics (odd multiples of 3) transferred to the DC side (e.g. through the grounded AC filters). A smoothing reactor is connected in series at each pole terminal.

To keep the DC side balanced, the level of the difference between the pole voltages has to be controlled and kept to zero (see the DC Voltage Balance Control block in the VSC Controller block).

The rectifier and the inverter are interconnected through a 75 km cable (2 pi sections). The use of underground cable is typical for VSC-HVDC links. A circuit breaker is used to apply a three-phase to ground fault on the inverter AC side. A Three-Phase Programmable Voltage Source block is used in station 1 system to apply voltage sags.

VSC Control System

Figure 5-18 shows an overview diagram of the VSC control system and its interface with the main circuit [3].

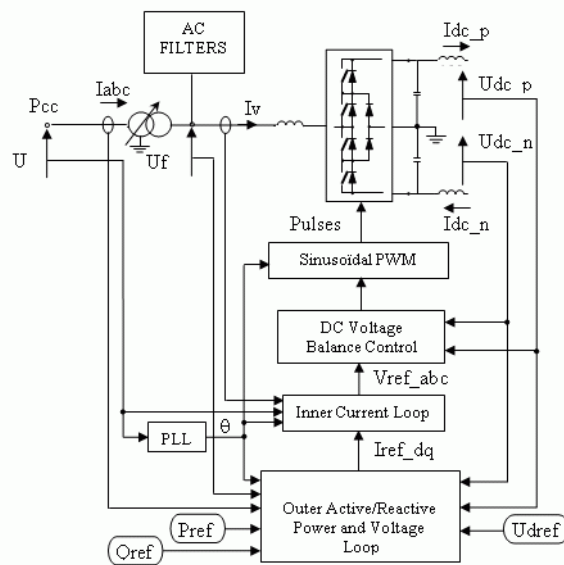

Figure 5-18: Overview of the Control System of a VSC Converter and Interface to the Main Circuit

The converter 1 and converter 2 controller designs are identical. The two controllers are independent with no communication between them. Each converter has two degrees of freedom. In our case, these are used to control:

- P and Q in station 1 (rectifier)
- Udc and Q in station 2 (inverter).

The control of the AC voltage would be also possible as an alternative to Q. This requires an extra regulator which is not implemented in our model.

A high level block diagram of the Simulink discrete VSC controller model is shown in Figure 5-19.

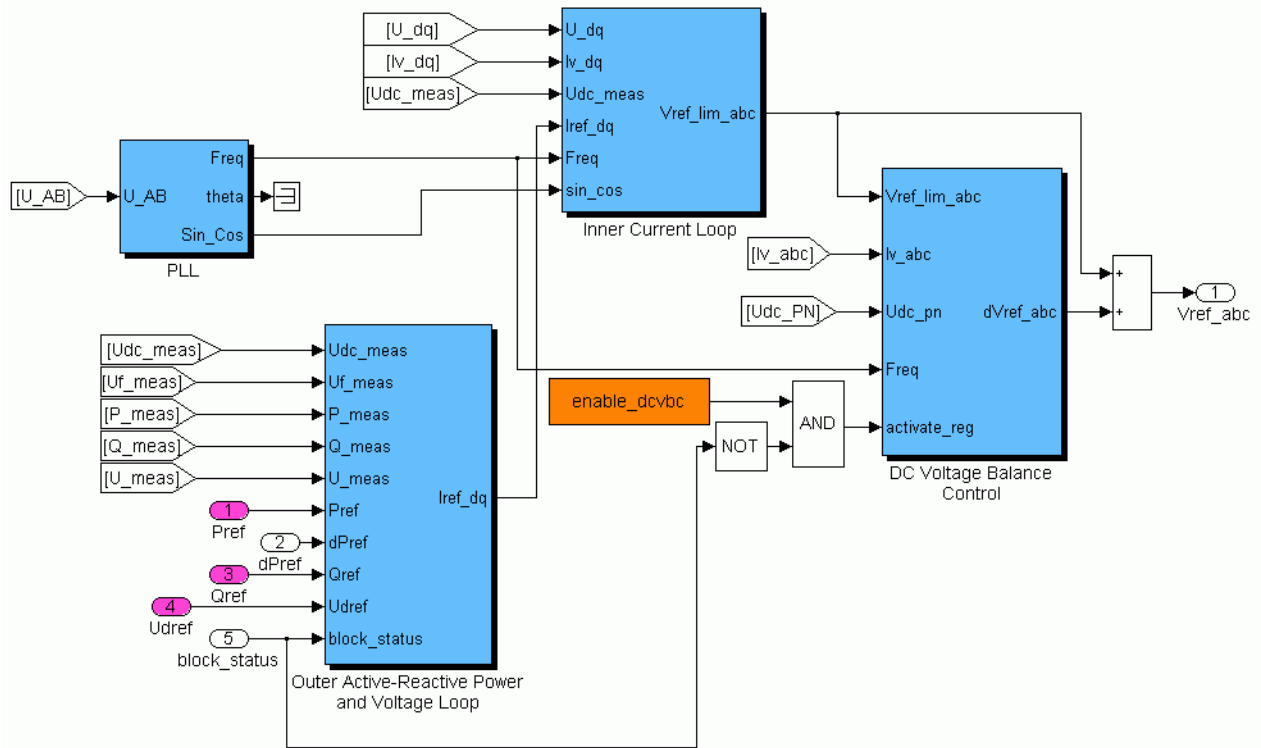

Figure 5-19: High Level Block Diagram of the Discrete VSC Controller

Open the VSC Controller subsystem to see the details.

The sample time of the controller model ($T_{s_Control}$) is $74.06 \mu s$, which is ten times the simulation sample time. The later is chosen to be one hundredth of

the PWM carrier period (i.e. 0.01/1350 s) giving an acceptable simulation precision. The power elements, the anti-aliasing filters and the PWM Generator block use the fundamental sample time (T_{s_Power}) of 7.406 μs . The unsynchronized PWM mode of operation is chosen for our model.

The normalized sampled voltages and currents (in p.u.) are provided to the controller.

The Clark Transformations block transforms the three-phase quantities to space vector components α and β (real and imaginary part). The signal measurements (U and I) on the primary side are rotated by $\pm\pi/6$ according to the transformer connection (YD11 or YD1) to have the same reference frame with the signal measured on the secondary side of the transformer (see block CLARK YD).

The dq transformations block computes the direct axis “d” and the quadratic axis “q” quantities (two axis rotating reference frame) from the α and β quantities.

The Signal Calculations block calculates and filters quantities used by the controller (e.g. active and reactive power, modulation index, DC current and voltage, etc.).

Phase Locked Loop (PLL)

The Phase Locked Loop block measures the system frequency and provides the phase synchronous angle θ (more precisely $[\sin(\theta), \cos(\theta)]$) for the dq Transformations block. In steady-state, $\sin(\theta)$ is in phase with the fundamental (positive sequence) of the α component and phase A of the PCC voltage (Uabc).

Outer Active and Reactive Power and Voltage Loop

The active and reactive power and voltage loop contains the outer loop regulators that calculates the reference value of the converter current vector (I_{ref_dq}) which is the input to the inner current loop. The control modes are: in the “d” axis, either the active power flow at the PCC or the pole-to-pole DC voltage; in the “q” axis, the reactive power flow at the PCC. Note that, it would be also possible to add an AC voltage control mode at the PCC in the “q” axis. The main functions of the Active and reactive power and voltage loop are described below.

The Reactive Power Control regulator block combines a PI control with a feedforward control to increase the speed response. To avoid integrator

wind-up the following actions are taken: the error is reset to zero, when the measured PCC voltage is less than a constant value (i.e. during an AC perturbation); when the regulator output is limited, the limitation error is fed back with the right sign, to the integrator input. The AC Voltage control override block, based on two PI regulators, will override the reactive power regulator to maintain the PCC AC voltage within a secure range, especially in steady-state.

The Active Power Control block is similar to the Reactive Power Control block. The extra Ramping block ramps the power order towards the desired value with an adjusted rate when the control is de-blocked. The ramped value is reset to zero when the converter is blocked. The DC Voltage control override block, based on two PI regulators, will override the active power regulator to maintain the DC voltage within a secure range, especially during a perturbation in the AC system of the station controlling the DC voltage.

The DC Voltage Control regulator block uses a PI regulator. The block is enabled when the Active Power Control block is disabled. The block output is a reference value, for the “d” component of converter current vector, for the Current Reference Limitation block.

The Current Reference Calculation block transforms the active and reactive power references, calculated by the P and Q controllers, to current references according to the measured (space vector) voltage at the filter bus. The current reference is estimated by dividing the power reference by the voltage (up to a minimum preset voltage value).

The current reference vector is limited to a maximum acceptable value (i.e. equipment dependent) by the Current Reference Limitation block. In power control mode, equal scaling is applied to the active and reactive power reference when a limit is imposed. In DC voltage control mode, higher priority is given to the active power when a limit is imposed for an efficient control of the voltage.

Inner Current Loop

The main functions of Inner Current Loop block are described below.

The AC Current Control block tracks the current reference vector (“d” and “q” components) with a feed forward scheme to achieve a fast control of the current at load changes and disturbances (e.g. so short-circuit faults do not exceed the references) [3] [5] [6]. In essence, it consists of knowing the U_{dq} vector voltages and computing what the converter voltages have to be, by adding the voltage

drops due to the currents across the impedance between the U and the PWM-VSC voltages. The state equations representing the dynamics of the VSC currents are used (an approximation is made by neglecting the AC filters). The “d” and “q” components are decoupled to obtain two independent first-order plant models. A proportional integral (PI) feedback of the converter current is used to reduce the error to zero in steady state. The output of the AC Current Control block is the unlimited reference voltage vector $V_{ref_dq_tmp}$.

The Reference Voltage Conditioning block takes into account the actual DC voltage and the theoretical maximum peak value of the fundamental bridge phase voltage in relation to the DC voltage to generate the new optimized reference voltage vector. In our model (i.e. a three-level NPC with carrier based PWM), the ratio between the maximum fundamental peak phase voltage and the DC total voltage (i.e. for a modulation index of 1) is $(\sqrt{2})/(\sqrt{3}) = 0.816$. By choosing a nominal line voltage of 100 kV at the transformer secondary bus and a nominal total DC voltage of 200 kV the nominal modulation index would be 0.816. In theory, the converter should be able to generate up to $1/0.816$ or 1.23 p.u. when the modulation index is equal to 1. This voltage margin is important for generating significant capacitive converter current (i.e. a reactive power flow to the AC system).

The Reference Voltage Limitation block limits the reference voltage vector amplitude to 1.0, since over modulation is not desired.

The Inverse dq and Inverse Clark transformation blocks are required to generate the three-phase voltage references to the PWM.

DC Voltage Balance Control

The DC Voltage Balance Control can be enabled or disabled. The difference between the DC side voltages (positive and negative) are controlled to keep the DC side of the three level bridge balanced (i.e. equal pole voltages) in steady-state. Small deviations between the pole voltages may occur at changes of active/reactive converter current or due to nonlinearity or lack of precision in the execution of the pulse width modulated bridge voltage. Furthermore, deviations between the pole voltages may be due to inherent unbalance in the circuit components impedance.

The DC midpoint current I_{d0} determines the difference U_{d0} between the upper and lower DC voltages (Figure 5-20) .

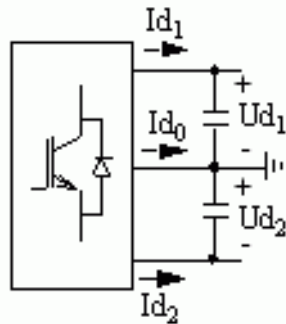

$$I_{d0} = -(I_{d1} + I_{d2}) = -C \cdot \frac{d}{dt}(U_{d1} - U_{d2}) = -C \cdot \frac{d}{dt}(U_{d0})$$

Figure 5-20: DC Voltages and Currents of the Three-Level Bridge

By changing the conduction time of the switches in a pole it is possible to change the average of the DC midpoint current I_{d0} and thereby control the difference voltage U_{d0} . For example, a positive difference ($U_{d0} \geq 0$) can be decreased to zero if the amplitude of the reference voltage which generates a positive midpoint current is increased at the same time as the amplitude of the reference voltage which generates a negative DC midpoint current is decreased. This is done by the addition of an offset component to the sinusoidal reference voltage. Consequently, the bridge voltage becomes distorted, and to limit the distortion effect, the control has to be slow. Finally, for better performance this function should be activated in the station controlling the DC voltage.

Dynamic Performance

In the next sections, the dynamic performance of the transmission system is verified by simulating and observing the

- Dynamic response to step changes applied to the principal regulator references, like active/reactive power and DC voltage
- Recovery from minor and severe perturbations in the AC system

For a comprehensive explanation of the procedure followed obtaining these results and more, refer to the Model Information block.

System Startup - Steady State and Step Response

The main waveforms from the scopes are reproduced below.

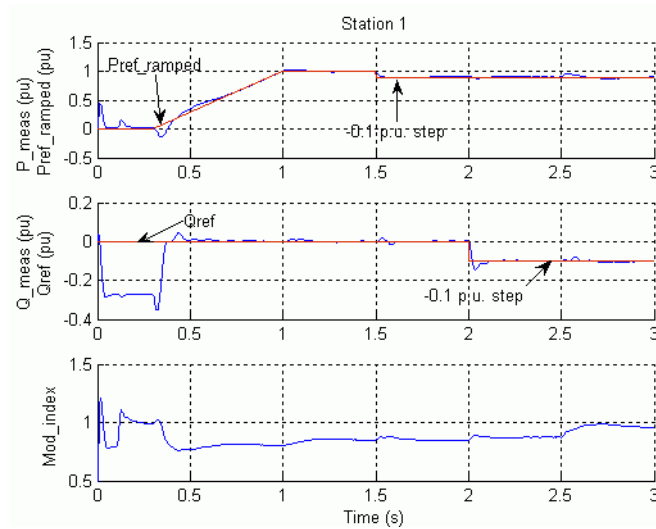

Startup and P & Q Step Responses in Station 1

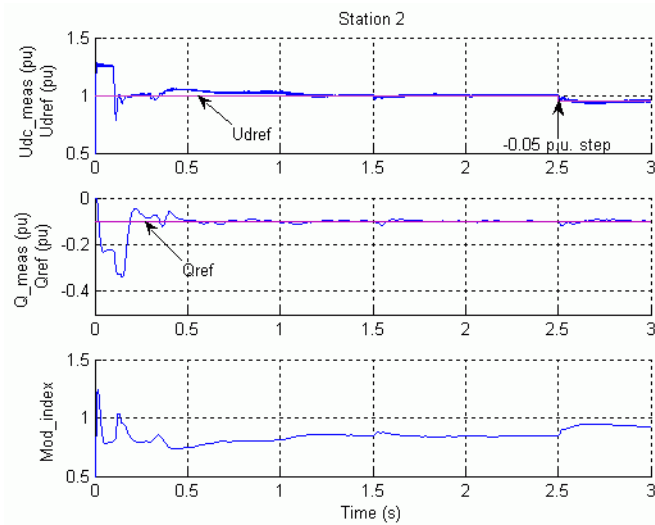

Startup and Udc Step Response in Station 2

Station 2 converter controlling DC voltage is first deblocked at $t=0.1$ s. Then, station 1 controlling active power converter is deblocked at $t=0.3$ s and power is ramped up slowly to 1 p.u. Steady state is reached at approximately $t=1.3$ s with DC voltage and power at 1.0 p.u. (200 kV, 200 MW). Both converters control the reactive power flow to a null value in station 1 and to 20 Mvar (-0.1 p.u.) into station 2 system.

After steady state has been reached, a -0.1 p.u. step is applied to the reference active power in converter 1 ($t=1.5$ s) and later a -0.1 p.u. step is applied to the reference reactive power ($t=2.0$ s). In station 2, a -0.05 p.u. step is applied to the DC voltage reference. The dynamic response of the regulators are observed. Stabilizing time is approximately 0.3 s. The control design attempts to decouple the active and reactive power responses. Note how the regulators are more or less mutually affected.

AC Side Perturbations

From the steady state condition, a minor and a severe perturbation are executed at station 1 and 2 systems respectively. A three-phase voltage sag is first applied at station 1 bus. Then, following the system recovery, a

three-phase to ground fault is applied at station 2 bus. The system recovery from the perturbations should be prompt and stable. The main waveforms from the scopes are reproduced in the two figures below.

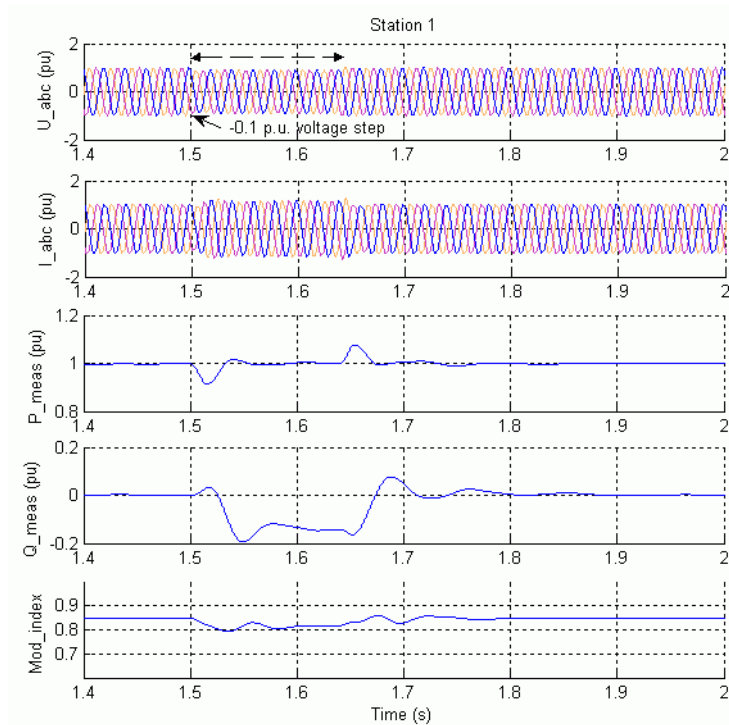

Voltage Step on AC System 1

The AC voltage step (-0.1 p.u.) is applied at $t=1.5$ s during 0.14 s (7 cycles) at station 1. The results show that the active and reactive power deviation from the pre-disturbance is less than 0.09 p.u. and 0.2 p.u. respectively. The recovery time is less than 0.3 s and the steady state is reached before next perturbation initiation.

The fault is applied at $t=2.1$ s during 0.12 s (6 cycles) at station 2.

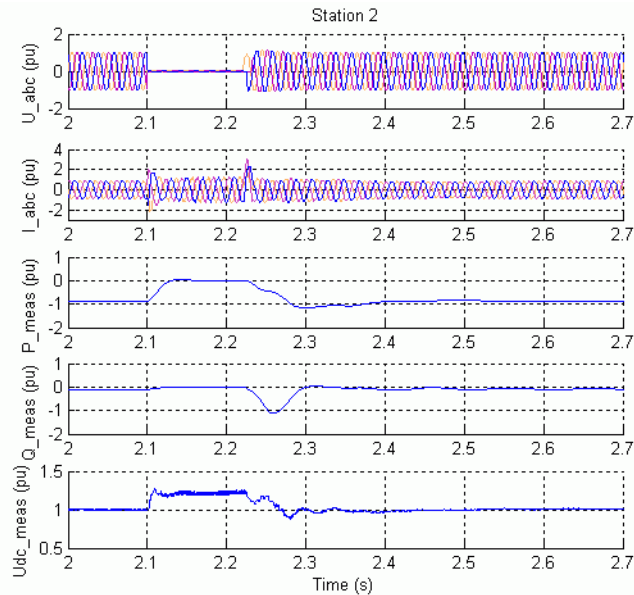

Three-Phase to Ground Fault at Station 2 Bus

Note that during the three-phase fault the transmitted DC power is almost halted and the DC voltage tends to increase (1.2 p.u.) since the DC side capacitance is being excessively charged. A special function (DC Voltage Control Override) in the Active Power Control (in station 1) attempts to limit the DC voltage within a fixed range. The system recovers well after the fault, within 0.5 s. Note the damped oscillations (around 10 Hz) in the reactive power.

References.

- [1] Weimers, L. "A New Technology for a Better Environment," *Power Engineering Review, IEEE*, vol. 18, issue 8, Aug. 1998.
- [2] Schettler F., Huang H., and Christl N. "HVDC transmission systems using voltage source converters – design and applications," *IEEE Power Engineering Society Summer Meeting*, July 2000.

- [3] Lindberg, Anders “PWM and control of two and three level high power voltage source converters,” *Licentiate thesis, ISSN-1100-1615, TRITA-EHE 9501*, The Royal Institute of Technology, Sweden, 1995.
- [4] Sadaba, Alonso, O., P. Sanchis Gurrpide, J. Lopez Tanerna, I. Munoz Morales, L. Marroyo Palomo, “Voltage Harmonics Generated by 3-Level Converters Using PWM Natural Sampling,” *Power Electronics Specialist Conference, 2001, IEEE 32nd Annual*, 17-21 June 2001, vol. 3, pp. 1561-1565.
- [5] Lu, Weixing, Boon-Teck Ooi, “Optimal Acquisition and Aggregation of Offshore wind Power by Multiterminal Voltage-Source HVDC,” *IEEE Trans. Power Delivery*, vol. 18, pp. 201-206, Jan. 2003.
- [6] Sao, K., P.W. Lehn, M.R. Iravani, J.A. Martinez, “A benchmark system for digital time-domain simulation of a pulse-width-modulated D-STATCOM,” *IEEE Trans. Power Delivery*, vol. 17, pp. 1113-1120, Oct. 2002.

Transient Stability of Power Systems Using Phasor Simulation

These case studies provide detailed, realistic examples of how to use the phasor simulation method of SimPowerSystems in typical power utility applications.

As explained in the section “Using the Phasor Solution Method for Stability Studies” on page 2-34, phasor simulation is the preferred method for simulating power grids when you are interested in the magnitude and phase of voltages and currents at fundamental frequency (50 Hz or 60 Hz). The phasor simulation is activated by means of the Powergui block. It supports all the elements of the **powerlib** library, including machines. In addition, two libraries of phasor models of power equipments found in utility grids (some of them including power electronics) have been introduced in this version of SimPowerSystems: the Flexible AC Transmission Systems (FACTS) library (factslib) and the Distributed Resources (DR) library (drlib). The case studies listed below show application examples of some of these phasor models.

Transient Stability of a Power System
with SVC and PSS (p. 6-2)

Use of a static var compensator (SVC) and power system stabilizers (PSS) for improving stability of a two-machine transmission system

Control of Power Flow Using a UPFC
and a PST (p. 6-8)

Control of power flow using a unified power flow controller (UPFC) and a phase shifting transformer (PST)

Wind Farm Using Doubly-Fed
Induction Generators (p. 6-18)

Study of a wind farm using doubly-fed induction generators driven by wind turbines

Transient Stability of a Power System with SVC and PSS

The example described in this section illustrates modeling of a simple transmission system containing two hydraulic power plants. A static var compensator (SVC) and power system stabilizers (PSS) are used to improve transient stability and power oscillation damping of the system. The power system illustrated in this example is quite simple. However, the phasor simulation method allows you to simulate more complex power grids.

If you are not familiar with the SVC and PSS, please see the reference pages for the following blocks: Static Var Compensator (Phasor Type), Generic Power System Stabilizer, and Multiband Power System Stabilizer.

Description of the Transmission System

The single line diagram shown below represents a simple 500 kV transmission system.

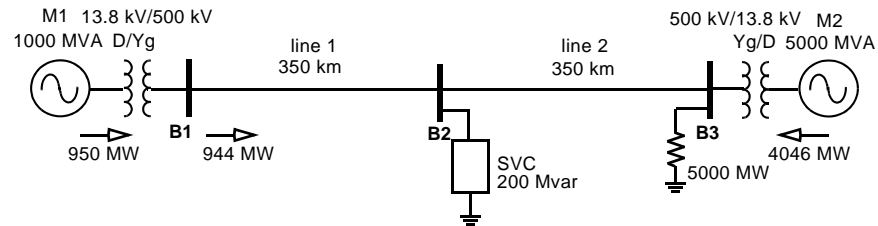

Figure 6-1: 500 kV Transmission System

A 1000 MW hydraulic generation plant (M1) is connected to a load center through a long 500 kV, 700 km transmission line. The load center is modeled by a 5000 MW resistive load. The load is fed by the remote 1000 MVA plant and a local generation of 5000 MVA (plant M2).

A load flow has been performed on this system with plant M1 generating 950 MW so that plant M2 produces 4046 MW. The line carries 944 MW which is close to its surge impedance loading (SIL = 977 MW). To maintain system stability after faults, the transmission line is shunt compensated at its center by a 200 Mvar static var compensator (SVC). The SVC does not have a power oscillation damping (POD) unit. The two machines are equipped with a

hydraulic turbine and governor (HTG), excitation system, and power system stabilizer (PSS).

This system is available in the `power_svc_pss` model. Load this model and save it in your working directory as `case1.mdl` to allow further modifications to the original system. This model is shown in Figure 6-2.

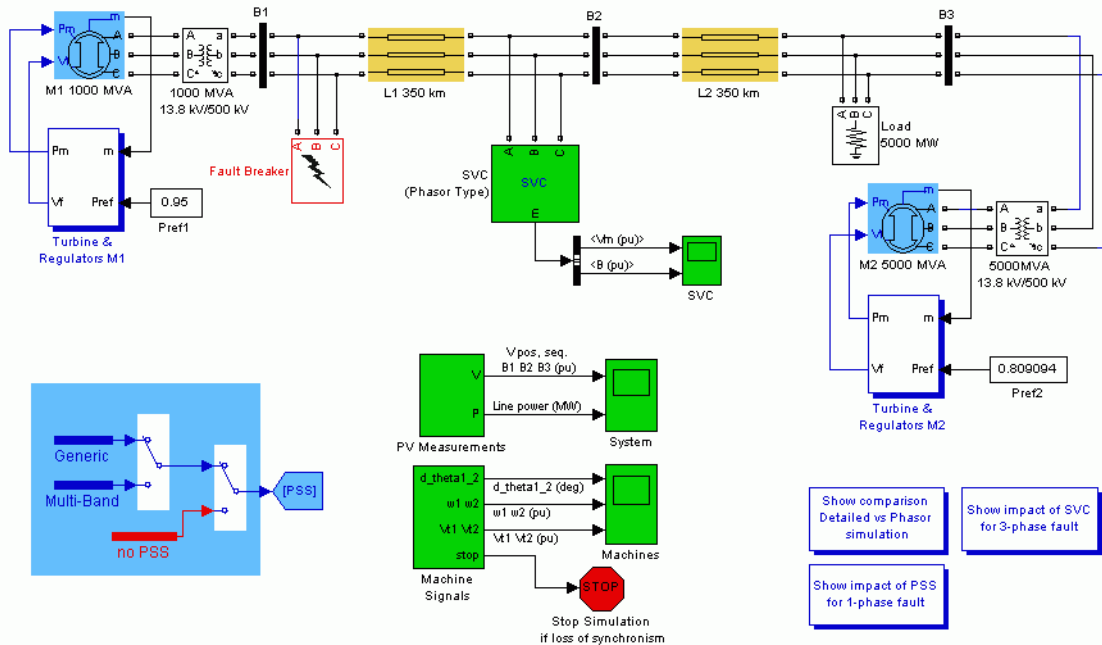

Figure 6-2: Model of the Transmission System (`power_svc_pss`)

First, look inside the two Turbine and Regulators subsystems to see how the HTG and the excitation system are implemented. Two types of stabilizers can be connected on the excitation system: a generic model using the acceleration power ($P_a =$ difference between mechanical power P_m and output electrical power P_{e0}) and a Multiband stabilizer using the speed deviation ($\Delta\omega$). These two stabilizers are standard models of the **powerlib**/Machines library. Manual Switch blocks surrounded by a blue zone allow you to select the type of stabilizer used for both machines or put the PSS out of service.

The SVC is the phasor model from the FACTS library. Open its dialog box and check in the Power data parameters that the SVC rating is ± 200 Mvar. In the

Control parameters, you can select either Voltage regulation or Var control (Fixed susceptance B_{ref}) mode. Initially the SVC is set in Var control mode with a susceptance $B_{ref}=0$, which is equivalent to having the SVC out of service.

A Fault Breaker block is connected at bus B1. You will use it to program different types of faults on the 500 kV system and observe the impact of the PSS and SVC on system stability.

To start the simulation in steady-state, the machines and the regulators have been previously initialized by means of the Load Flow and Machine Initialization utility of the Powergui block. Load flow has been performed with machine M1 defined as a PV generation bus ($V=13800$ V, $P=950$ MW) and machine M2 defined as a swing bus ($V=13800$ V, 0 degrees). After the load flow has been solved, the reference mechanical powers and reference voltages for the two machines have been automatically updated in the two constant blocks connected at the HTG and excitation system inputs: $P_{ref1}=0.95$ p.u. (950 MW), $V_{ref1}=1.0$ p.u.; $P_{ref2}=0.8091$ p.u. (4046 MW), $V_{ref2}=1.0$ p.u.

Single-Phase Fault – Impact of PSS – No SVC

Verify that the PSSs (Generic Pa type) are in service and that a 6-cycle single-phase fault is programmed in the Fault Breaker block (Phase A checked, fault applied at $t=0.1$ s and cleared at $t=0.2$ s).

Start the simulation and observe signals on the Machines scope. For this type of fault the system is stable without SVC. After fault clearing, the 0.6 Hz oscillation is quickly damped. This oscillation mode is typical of interarea oscillations in a large power system. First trace on the Machines scope shows the rotor angle difference d_theta1_2 between the two machines. Power transfer is maximum when this angle reaches 90 degrees. This signal is a good indication of system stability. If d_theta1_2 exceeds 90 degrees for too long a period of time, the machines will lose synchronism and the system goes unstable. Second trace shows the machine speeds. Notice that machine 1 speed increases during the fault because during that period its electrical power is lower than its mechanical power. By simulating over a long period of time (50 seconds) you will also notice that the machine speeds oscillate together at a low frequency (0.025 Hz) after fault clearing. The two PSSs (Pa type) succeed to damp the 0.6 Hz mode but they are not efficient for damping the 0.025 Hz mode. If you select instead the Multi-Band PSS, you will notice that this stabilizer type succeeds to damp both the 0.6 Hz mode and the 0.025 Hz mode.

You will now repeat the test with the two PSSs out of service. Restart simulation. Notice that the system is unstable without PSS. You can compare results with and without PSS by double-clicking on the blue block on the right side labeled “Show impact of PSS for 1-phase fault.” The displayed waveforms are reproduced below.

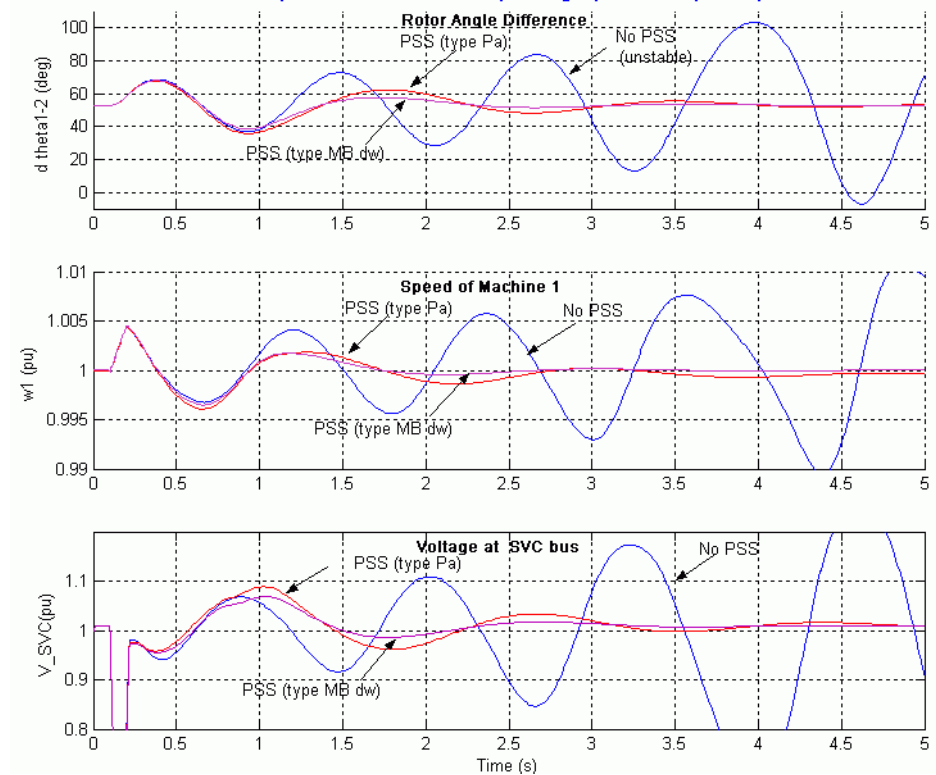

Impact of PSS for a Single-Phase Fault

Note This system is naturally unstable without PSS. If you remove the fault (by deselecting phase A in the Fault Breaker), you will see the instability slowly building up at approximately 1 Hz after a few seconds.

Three-Phase Fault – Impact of SVC – PSS in Service

You will now apply a 3-phase fault and observe the impact of the SVC for stabilizing the network during a severe contingency.

First put the two PSS (Generic Pa type) in service. Reprogram the Fault Breaker block to apply a 3-phase-to-ground fault. Verify that the SVC is in fixed susceptance mode with $B_{ref} = 0$. Start the simulation. By looking at the `d_theta1_2` signal, you should observe that the two machines quickly fall out of synchronism after fault clearing. In order not to pursue unnecessary simulation, the Simulink Stop block is used to stop the simulation when the angle difference reaches 3×360 degrees.

Now open the SVC block menu and change the SVC mode of operation to Voltage regulation. The SVC will now try to support the voltage by injecting reactive power on the line when the voltage is lower than the reference voltage (1.009 pu). The chosen SVC reference voltage corresponds to the bus voltage with the SVC out of service. In steady state the SVC will therefore be floating and waiting for voltage compensation when voltage departs from its reference set point.

Restart simulation and observe that the system is now stable with a 3-phase fault. You can compare results with and without SVC by double clicking on the blue block labeled “Show impact of SCV for 3-phase fault.” The displayed waveforms are reproduced below.

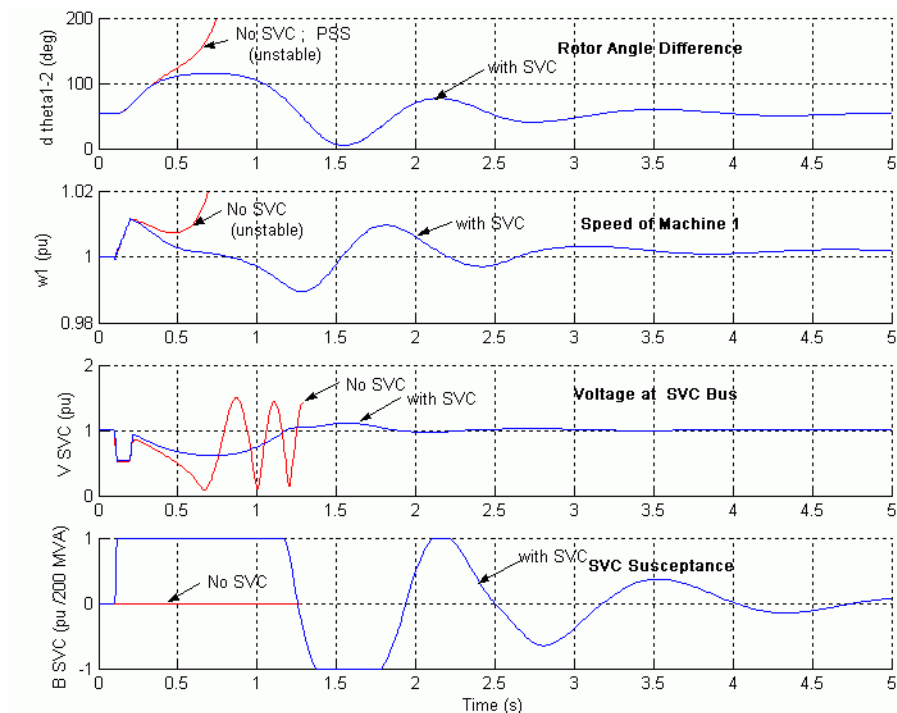

Impact of the SVC for a Three-Phase Fault

Control of Power Flow Using a UPFC and a PST

The example described in this section illustrates application of SimPowerSystems to study the steady-state and dynamic performance of a unified power flow controller (UPFC) used to relief power congestion in a transmission system.

If you are not familiar with the UPFC, please see the reference page for the Unified Power Flow Controller (Phasor Type) block.

Description of the Power System

The single-line diagram of the modeled power system is shown in Figure 6-3.

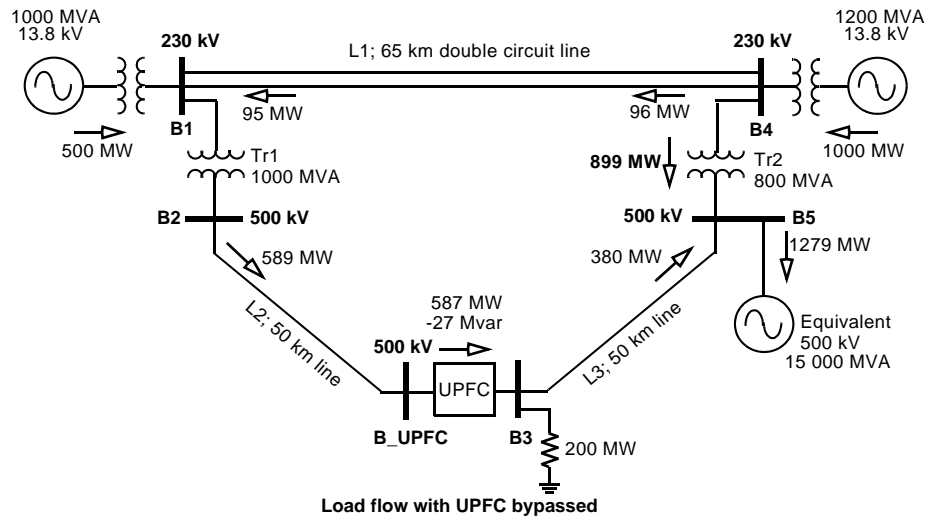

Figure 6-3: 500 kV / 230 kV Transmission System

A UPFC is used to control the power flow in a 500 kV / 230 kV transmission system. The system, connected in a loop configuration, consists essentially of five buses (B1 to B5) interconnected through three transmission lines (L1, L2, L3) and two 500 kV/230 kV transformer banks Tr1 and Tr2. Two power plants located on the 230 kV system generate a total of 1500 MW which is transmitted to a 500 kV, 15000 MVA equivalent and to a 200 MW load connected at bus B3. Each plant model includes a speed regulator, an excitation system as well as a

power system stabilizer (PSS). In normal operation, most of the 1200 MW generation capacity of power plant #2 is exported to the 500 kV equivalent through two 400 MVA transformers connected between buses B4 and B5. For this demo we are considering a contingency case where only two transformers out of three are available ($\text{Tr2} = 2 \times 400 \text{ MVA} = 800 \text{ MVA}$). The load flow shows that most of the power generated by plant #2 is transmitted through the 800 MVA transformer bank (899 MW out of 1000 MW) and that 96 MW is circulating in the loop. Transformer Tr2 is therefore overloaded by 99 MVA. The example illustrates how a UPFC can relieve this power congestion. The UPFC located at the right end of line L2 is used to control the active and reactive powers at the 500 kV bus B3, as well as the voltage at bus B_UPFC. The UPFC consists of two 100 MVA, IGBT-based, converters (one shunt converter and one series converter interconnected through a DC bus). The series converter can inject a maximum of 10% of nominal line-to-ground voltage (28.87 kV) in series with line L2.

This example is available in the power_upfc model. Load this model and save it in your working directory as case2.mdl to allow further modifications to the original system. This model is shown in Figure 6-4.

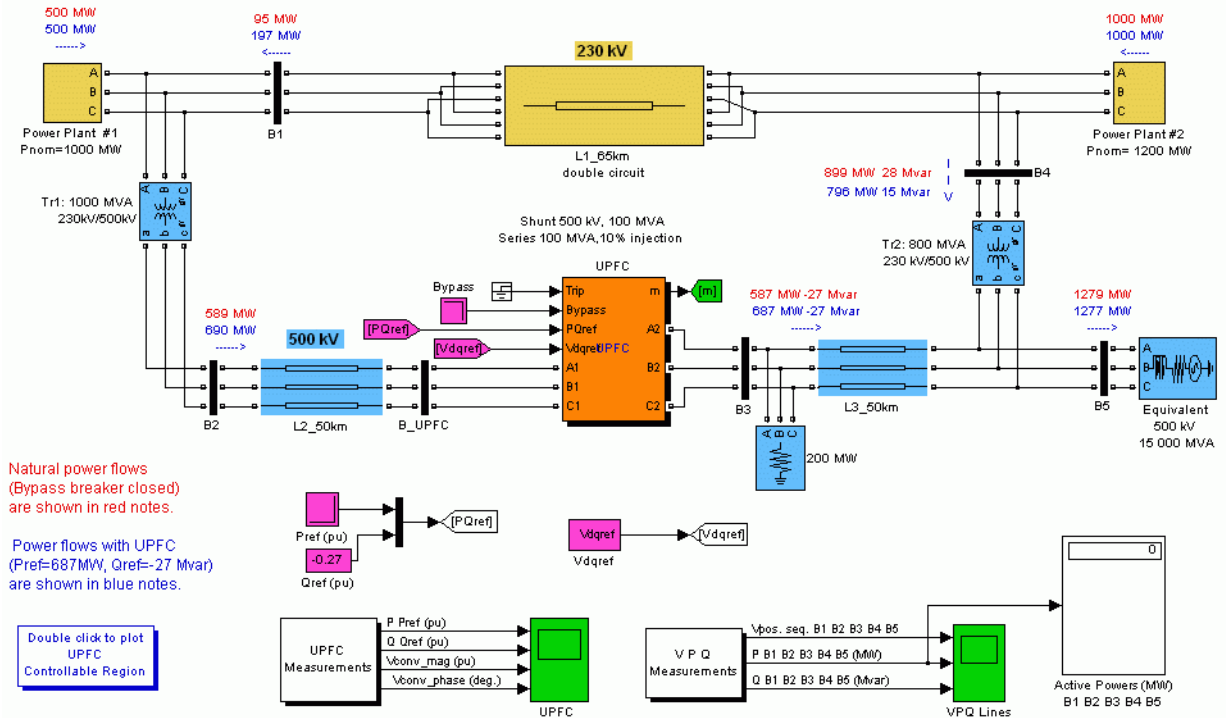

Figure 6-4: Model of the UPFC Controlling Power on a 500 kV/230 kV Power System (power_upfc)

Using the load flow option of the Powergui block, the model has been initialized with plants #1 and #2 generating respectively 500 MW and 1000 MW and with the UPFC out of service (Bypass breaker closed). The resulting power flow obtained at buses B1 to B5 is indicated on the model by red numbers. This load flow corresponds to load flow shown in the single-line diagram, in Figure 6-3.

Power Flow Control with the UPFC

Parameters of the UPFC are given in the dialog box. Verify, in the Power data parameters, that the series converter is rated 100 MVA with a maximum voltage injection of 0.1 p.u. The shunt converter is also rated 100 MVA. Also verify, in the control parameters, that the shunt converter is in Voltage regulation mode and that the series converter is in Power flow control mode. The UPFC reference active and reactive powers are set in the magenta blocks labeled $P_{ref}(pu)$ and $Q_{ref}(pu)$. Initially the Bypass breaker is closed and the resulting natural power flow at bus B3 is 587 MW and -27 Mvar. The P_{ref} block is programmed with an initial active power of 5.87 p.u. corresponding to the natural power flow. Then, at $t=10s$, P_{ref} is increased by 1 p.u. (100 MW), from 5.87 p.u. to 6.87 pu, while Q_{ref} is kept constant at -0.27 pu.

Run the simulation and look on the UPFC scope how P and Q measured at bus B3 follow the reference values. Waveforms are reproduced below.

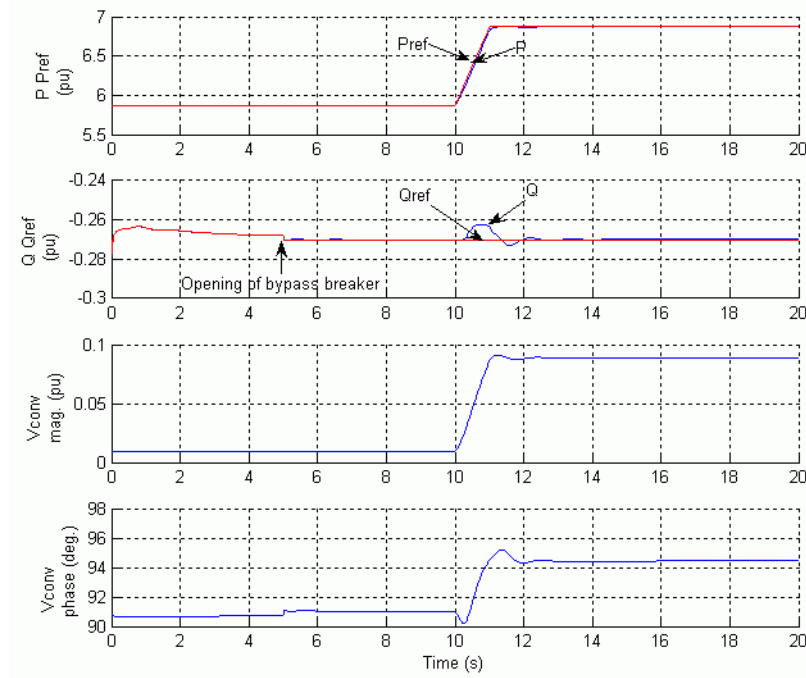

UPFC Dynamic Response to a Change in Reference Power from 587 MW to 687 MW

At $t=5$ s, when the Bypass breaker is opened, the natural power is diverted from the Bypass breaker to the UPFC series branch without noticeable transient. At $t=10$ s, the power increases at a rate of 1 pu/s. It takes one second for the power to increase to 687 MW. This 100 MW increase of active power at bus B3 is achieved by injecting a series voltage of 0.089 p.u. with an angle of 94 degrees. This results in an approximate 100 MW decrease in the active power flowing through Tr2 (from 899 MW to 796 MW), which now carries an acceptable load. See the variations of active powers at buses B1 to B5 on the VPQ Lines scope.

UPFC P-Q Controllable Region

Now, open the UPFC dialog box and select Show Control parameters (series converter). Select Mode of operation = Manual Voltage injection. In this control mode the voltage generated by the series inverter is controlled by two external signals V_d , V_q multiplexed at the V_{dqref} input and generated in the V_{dqref} magenta block. For the first five seconds the Bypass breaker stays closed, so that the PQ trajectory stays at the (-27Mvar, 587 MW) point. Then when the breaker opens, the magnitude of the injected series voltage is ramped, from 0.0094 to 0.1 p.u. At 10 s, the angle of the injected voltage starts varying at a rate of 45 deg./s.

Run the simulation and look on the UPFC scope the P and Q signals who vary according to the changing phase of the injected voltage. At the end of the simulation, double-click on the blue block labeled “Double click to plot UPFC Controllable Region.” The trajectory of the UPFC reactive power as function of its active power, measured at bus B3, is reproduced below. The area located inside the ellipse represents the UPFC controllable region.

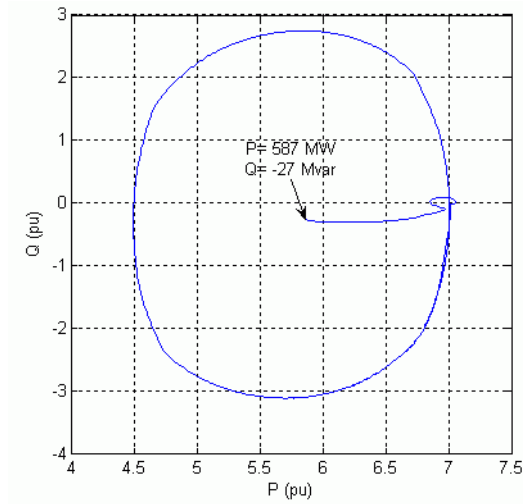

UPFC Controllable Region

Power Flow Control Using a PST

Although not as flexible as the UPFC, the phase shifting transformer (PST) is nevertheless a very efficient means to control power flow because it acts directly on the phase angle δ , as shown in Figure 6-5. The PST is the most commonly used device to control power flow on power grids.

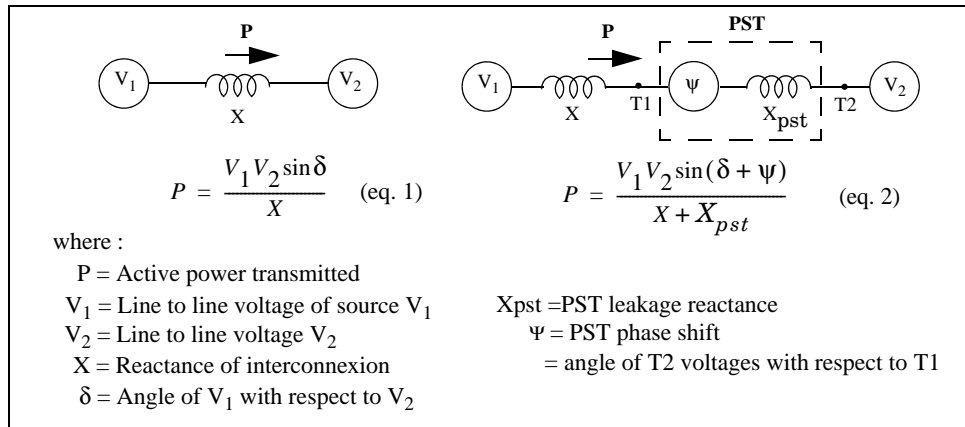

Figure 6-5: Power Transfer Between Two Voltage Sources Without and With PST

You will now use a PST with an on load tap changer (OLTC) to control the power flow on your power system. A phasor model of PST using the delta hexagonal connection is available in the FACTS/Transformers library. For details on this PST connection, please refer to the Three-Phase OLTC Phase Shifting Transformer Delta-Hexagonal (Phasor Type) block reference page.

Delete the UPFC block in your model as well as the magenta blocks controlling the UPFC. Also delete the UPFC Measurements subsystem and the UPFC scope. Open the Transformer subsystem of the FACTS library and copy the Three-Phase OLTC Phase Shifting Transformer Delta-Hexagonal (Phasor Type) block in your model. Connect the ABC terminals to the B_UPFC bus and connect the abc terminals to the B3 bus. Now, open the PST block dialog box and modify the following parameters:

**Nominal parameters [Vnom(Vrms Ph Ph) [500e3 800e6 60]
Pnom(VA) Fnom (Hz)]**

Number of taps per half tapped winding 20

The nominal power is set to 800 MVA (maximum expected power transfer through the PST). The number of taps is set to 20, so that the phase shift resolution is approximately 60/20= 3 degrees per step.

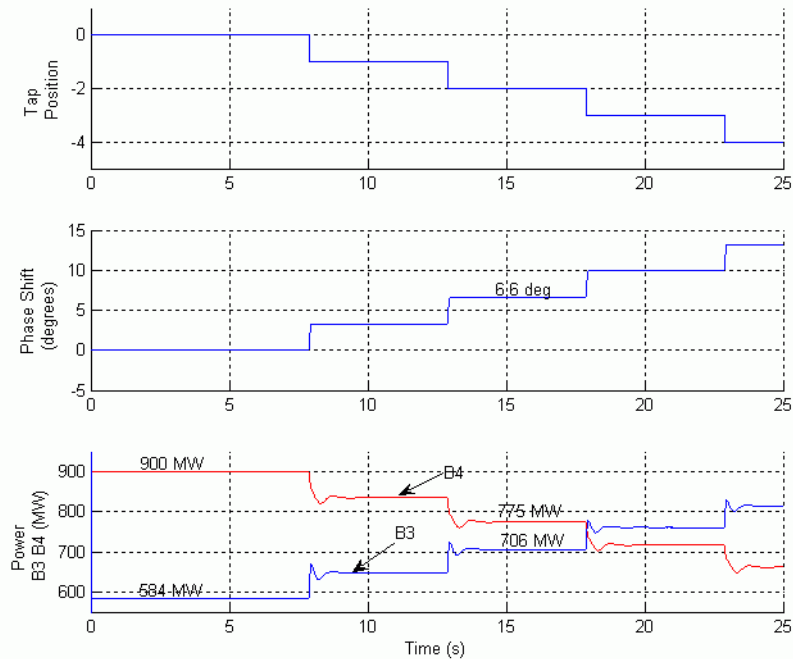

Control of Active Power Through B3 and B4 by Changing Tap Position of PST

Each tap change produces a phase angle variation of approximately 3 degrees, resulting in a 60 MW power increase through B3. At tap position -2, the power through transformer Tr2 as decreased from 900 MW to 775 MW, thus achieving the same goal as the UPFC for steady state control. You could get a better resolution in phase angle and power steps by increasing the number of taps in the OLTC.

You can notice that the discrete variation of phase angle produces overshoots and slight oscillations in active power. These power oscillations which are typical interarea electromechanical oscillations of machines in power plants 1 and 2 are quickly damped by the power system stabilizers (PSSs) connected on the excitation systems.

If you disconnect the PSS from the vstab input of the excitation system (located in the Reg_M1 and Reg_M2 subsystems of the power plants) you will realize the impact of PSS on interarea oscillation damping. The active power through

B3 with and without PSS is reproduced below. Without PSS, the 1.2 Hz under damped power oscillations are clearly unacceptable.

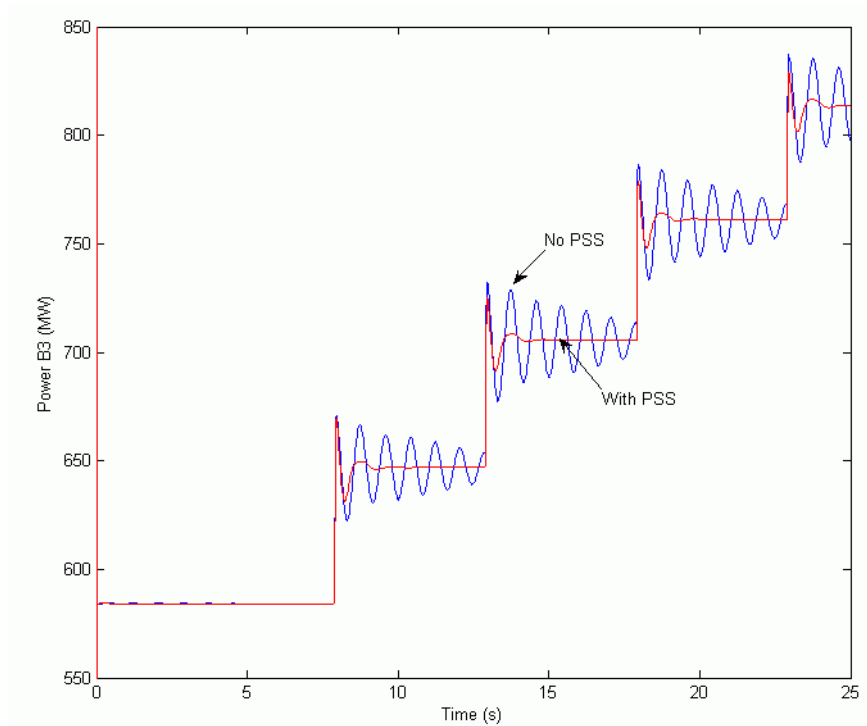

Damping of Power Oscillations by PSS

Wind Farm Using Doubly-Fed Induction Generators

The example described in this section illustrates application of SimPowerSystems to study the steady-state and dynamic performance of a 9 MW wind farm connected to a distribution system.

The wind farm consists of six 1.5 MW wind turbines connected to a 25 kV distribution system exporting power to a 120 kV grid through a 30 km 25 kV feeder. A 2300V, 2 MVA plant consisting of a motor load (1.68 MW induction motor at 0.93 PF) and of a 200 kW resistive load is connected on the same feeder at bus B25. A 500 kW load is also connected on the 575 V bus of the wind farm. The single-line diagram of this system is illustrated in Figure 6-6.

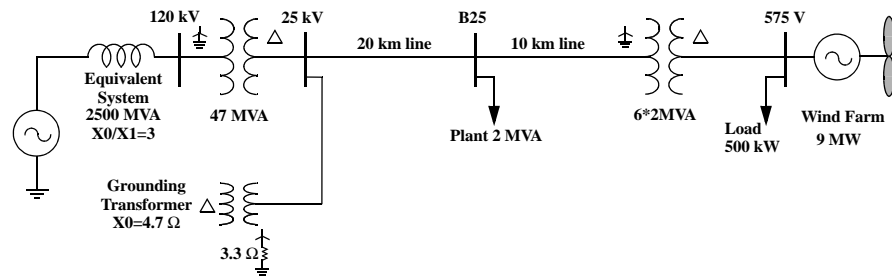

Figure 6-6: Single-Line Diagram of the Wind Farm Connected to a Distribution System

Both the wind turbine and the motor load have a protection system monitoring voltage, current and machine speed. The DC link voltage of the DFIG is also monitored. Wind turbines use a doubly-fed induction generator (DFIG) consisting of a wound rotor induction generator and an AC/DC/AC IGBT-based PWM converter. The stator winding is connected directly to the 60 Hz grid while the rotor is fed at variable frequency through the AC/DC/AC converter. The DFIG technology allows extracting maximum energy from the wind for low wind speeds by optimizing the turbine speed, while minimizing mechanical stresses on the turbine during gusts of wind. The optimum turbine speed producing maximum mechanical energy for a given wind speed is proportional to the wind speed (see Wind Turbine Doubly-Fed Induction Generator (Phasor Type) block of the DRlib/Wind Generation library for more details). Another

advantage of the DFIG technology is the ability for power electronic converters to generate or absorb reactive power, thus eliminating the need for installing capacitor banks as in the case of squirrel-cage induction generators.

This system is available in the power_wind_dfig model. Load this model and save it in your working directory as case3.mdl to allow further modifications to the original system. The SimPowerSystems diagram is shown in Figure 6-7 and Figure 6-8. In this case study, the rotor is running at subsynchronous speed for wind speeds lower than 10 m/s and it is running at a super-synchronous speed for higher wind speeds. The turbine mechanical power as function of turbine speed is displayed in Figure 6-9 for wind speeds ranging from 5 m/s to 16.2 m/s. These characteristics are obtained with the specified parameters of the Turbine data (Figure 6-9).

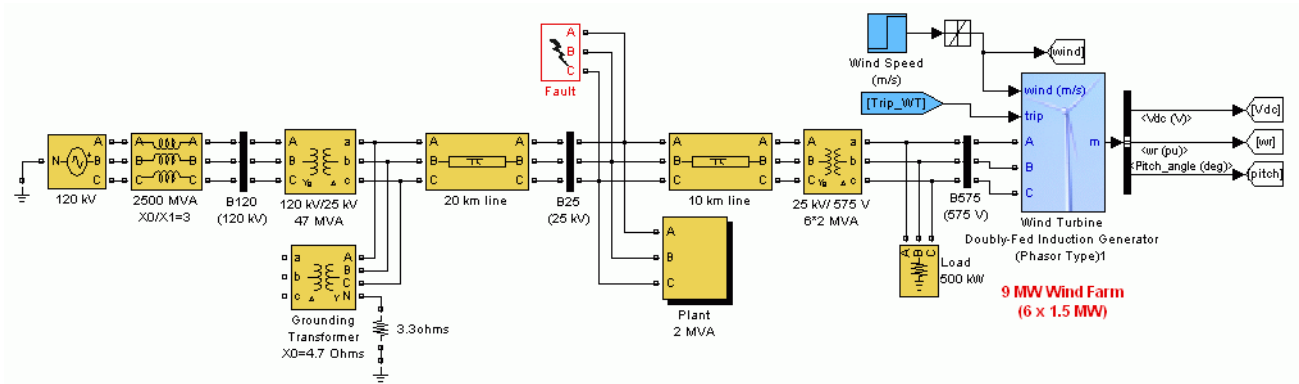

Figure 6-7: SimPowerSystems Diagram of the Wind Farm Connected to the Distribution System (power_wind_dfig)

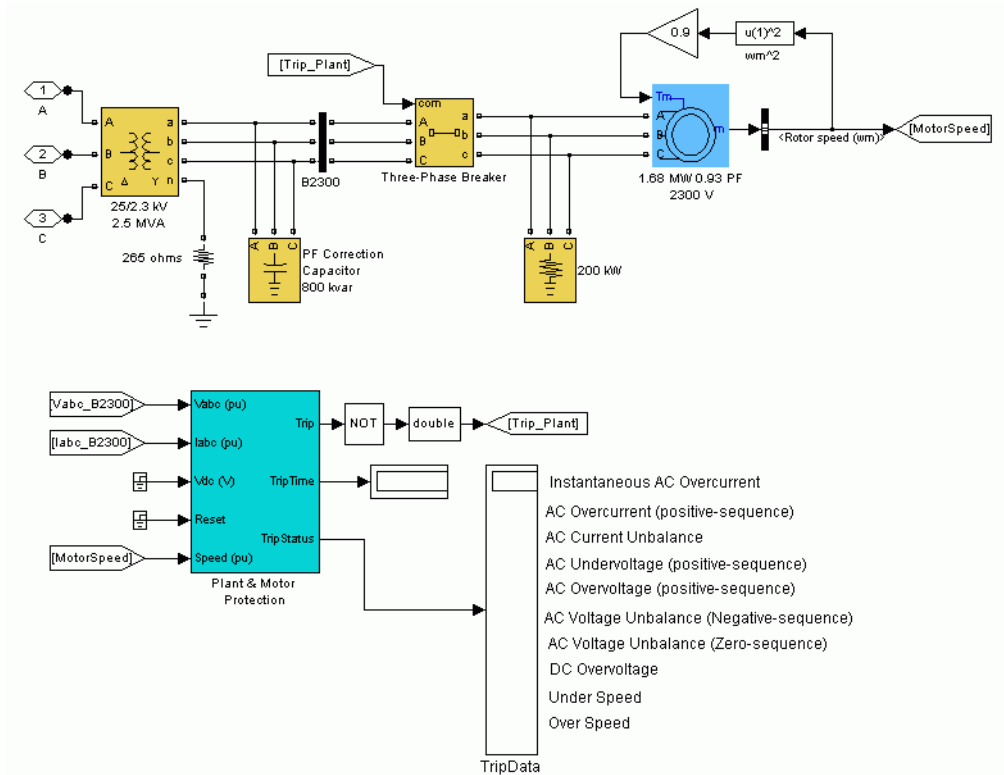

Figure 6-8: SimPowerSystems Diagram of the 2 MVA Plant with Its Protection System

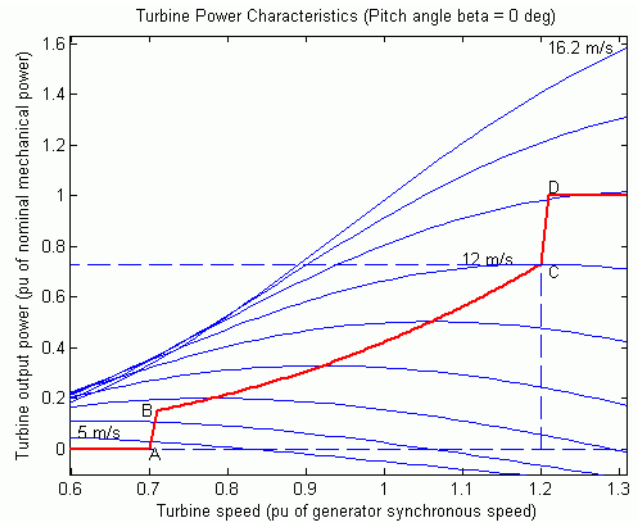
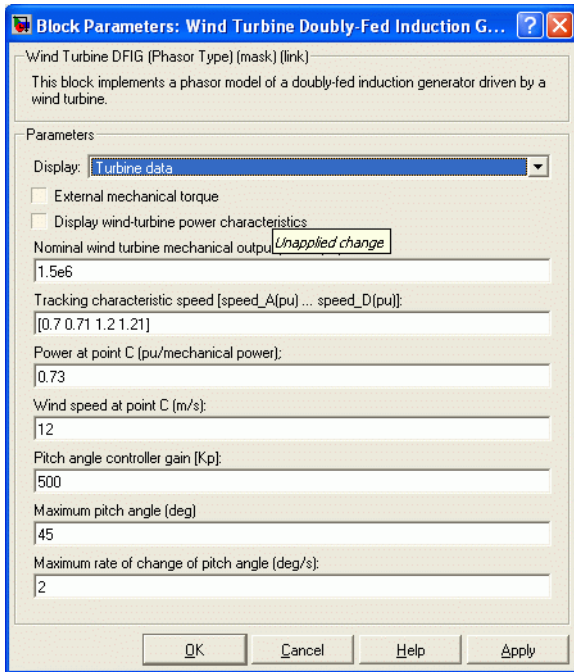

Figure 6-9: Turbine Data Menu and the Turbine Power Characteristics

The DFIG is controlled to follow the ABCD curve in Figure 6-9. Turbine speed optimization is obtained between point B and point C on this curve.

The wind turbine model is a phasor model that allows transient stability type studies with long simulation times. In this case study, the system is observed during 50 s. The 6-wind-turbine farm is simulated by a single wind-turbine block by multiplying the following three parameters by six, as follows:

- The nominal wind turbine mechanical output power: $6 \cdot 1.5e6$ watts, specified in the Turbine data menu
- The generator rated power: $6 \cdot 1.5 / 0.9$ MVA ($6 \cdot 1.5$ MW at 0.9 PF), specified in the Generator data menu

- The nominal DC bus capacitor: 6×10000 microfarads, specified in the Converters data menu

The mode of operation is set to Voltage regulation in the **Control Parameters** dialog box. The terminal voltage will be controlled to a value imposed by the reference voltage ($V_{ref}=1$ pu) and the voltage droop ($X_s=0.02$ pu).

Turbine Response to a Change in Wind Speed

Observe the turbine response to a change in wind speed. Initially, wind speed is set at 8 m/s, and then at $t=5$ s, wind speed increases suddenly at 14 m/s. Figure 6-10 illustrates the waveforms associated with this simulation. At $t=5$ s, the generated active power starts increasing smoothly (together with the turbine speed) to reach its rated value of 9MW in approximately 15s. Over that time frame the turbine speed increases from 0.8 p.u. to 1.21 pu. Initially, the pitch angle of the turbine blades is zero degree and the turbine operating point follows the red curve of the turbine power characteristics up to point D. Then the pitch angle is increased from 0 deg to 0.76 deg to limit the mechanical power. Observe also the voltage and the generated reactive power. The reactive power is controlled to maintain a 1 p.u. voltage. At nominal power, the wind turbine absorbs 0.68 Mvar (generated $Q=-0.68$ Mvar) to control voltage at 1pu. If you change the mode of operation to Var regulation with the **Generated reactive power Q_{ref}** set to zero, you will observe that the voltage increases to 1.021 p.u. when the wind turbine generates its nominal power at unity power factor (Figure 6-11).

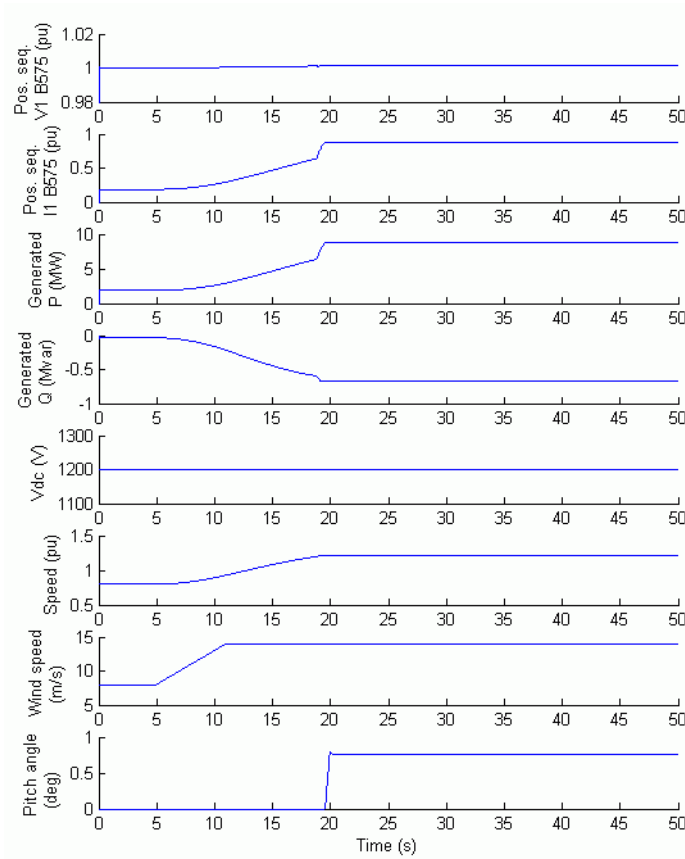

Figure 6-10: Waveforms for a Gust of Wind (Wind Farm in Voltage Regulation Mode)

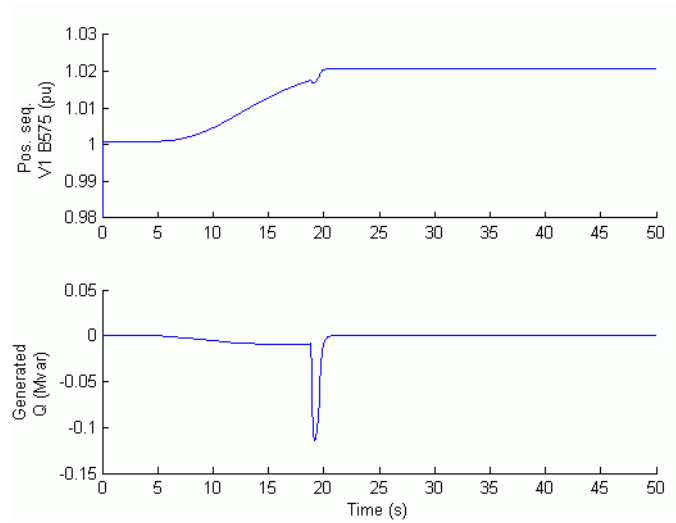

Figure 6-11: Waveforms for a Gust of Wind (Wind Farm in Var Regulation Mode)

Simulation of a Voltage Sag on the 120-kV System

Now observe the impact of a voltage sag resulting from a remote fault on the 120 kV system. In this simulation the mode of operation is initially Var regulation with $Q_{ref}=0$ and the wind speed is constant at 8 m/s. A 0.15 p.u. voltage drop lasting 0.5 s is programmed, in the 120 kV voltage source menu, to occur at $t=5$ s. The simulation results are illustrated in Figure 6-12. Observe the plant voltage and current as well as the motor speed. Note that the wind farm produces 1.87 MW. At $t=5$ s, the voltage falls below 0.9 p.u. and at $t=5.22$ s, the protection system trips the plant because an undervoltage lasting more than 0.2 s has been detected (exceeding protection settings for the Plant subsystem). The plant current falls to zero and motor speed decreases gradually, while the wind farm continues generating at a power level of 1.87 MW. After the plant has tripped, 1.25 MW of power (P_{B25} measured at bus B25) is exported to the grid.

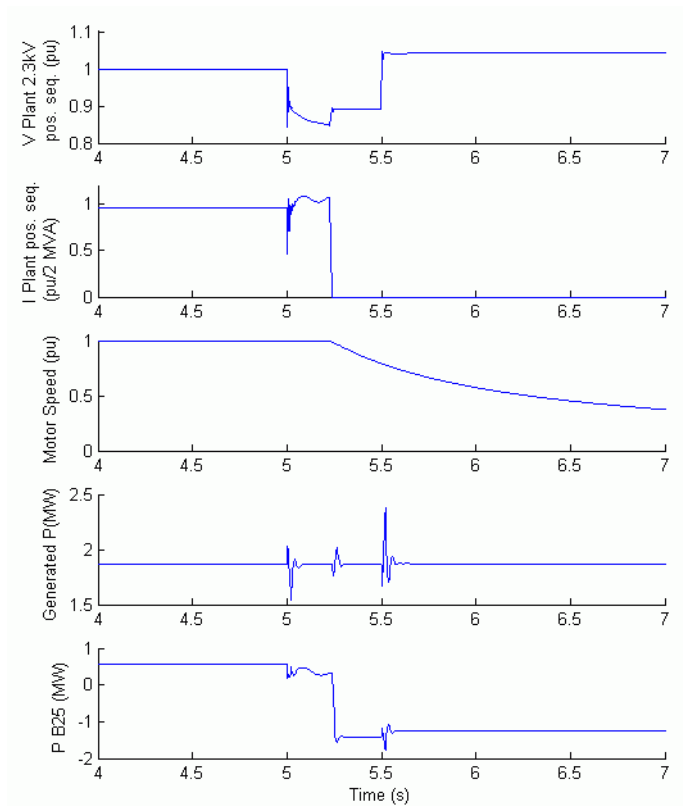

Figure 6-12: Voltage Sag on the 120 kV System (Wind Farm in Var Regulation Mode)

Now, the wind turbine control mode is changed to Voltage regulation and the simulation is repeated. You will notice that the plant does not trip anymore. This is because the voltage support provided by the 5 Mvar reactive power generated by the wind turbines during the voltage sag keeps the plant voltage above the 0.9 p.u. protection threshold. The plant voltage during the voltage sag is now 0.93 p.u. (Figure 6-13).

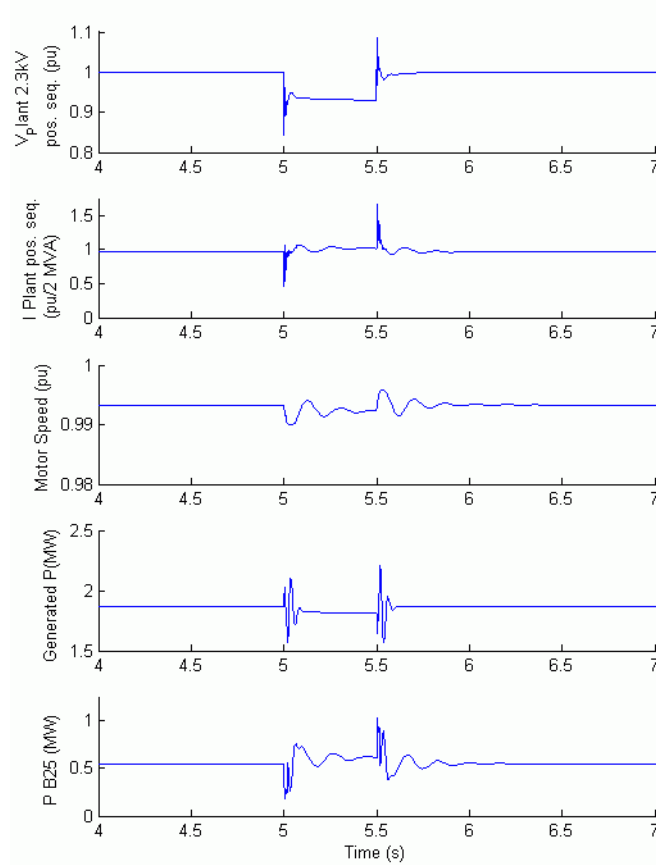

Figure 6-13: Voltage Sag on the 120 kV System (Wind Farm in Voltage Regulation Mode)

Simulation of a Fault on the 25-kV System

Finally, now observe the impact of a single phase-to-ground fault occurring on the 25 kV line. At $t=5$ s a 9 cycle (0.15 s) phase-to-ground fault is applied on phase A at B25 bus. When the wind turbine is in Voltage regulation mode, the positive sequence voltage at wind turbine terminals ($V1_B575$) drops to 0.8 p.u. during the fault, which is above the undervoltage protection threshold

(0.75 p.u. for a $t > 0.1$ s). The wind farm therefore stays in service (Figure 6-14). However, if the Var regulation mode is used with $Q_{ref}=0$, the voltage drops under 0.7 p.u. and the undervoltage protection trips the wind farm. We can now observe that the turbine speed increases. At $t=40$ s the pitch angle starts to increase to limit the speed (Figure 6-15).

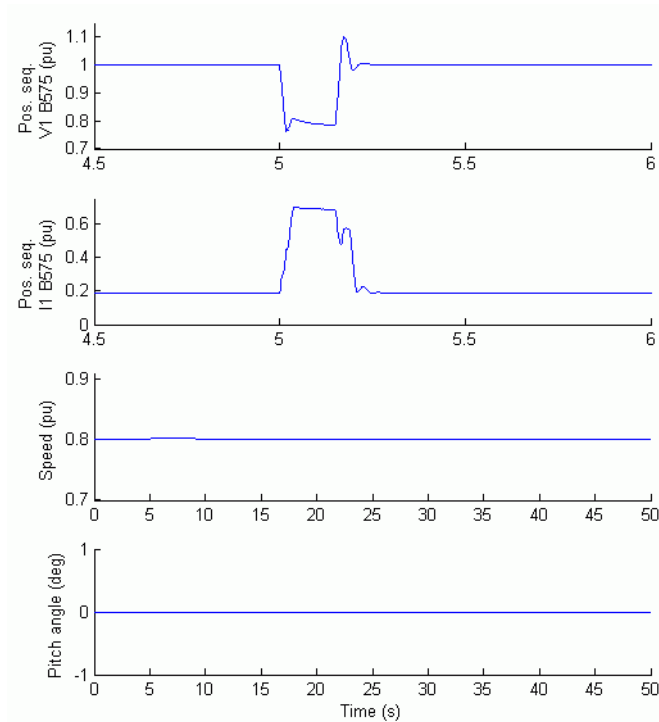

Figure 6-14: Wind Farm Waveforms During Fault at Bus B25 (Wind Farm in Voltage Regulation Mode)

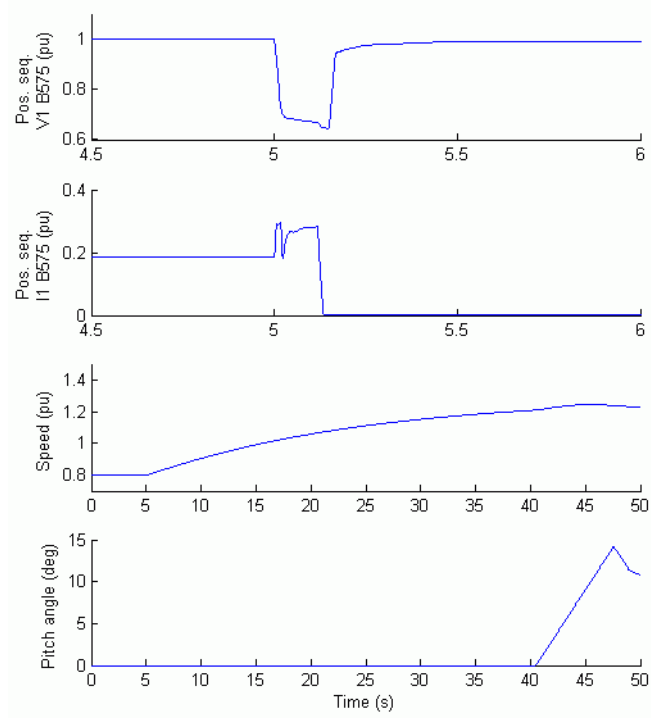

Figure 6-15: Wind Farm Waveforms During Fault at Bus B25 (Wind Farm in Var Regulation Mode)

SimPowerSystems Block Reference

- | | |
|--------------------------------------|--|
| Blocks — By Category (p. 7-2) | The SimPowerSystems blocks summarized by block library |
| Blocks — Alphabetical List (p. 7-11) | The SimPowerSystems blocks listed alphabetically by name |

Blocks – By Category

The SimPowerSystems main library, **powerlib**, organizes its blocks into libraries according to their behavior. The **powerlib** window displays the block library icons and names. This section lists all SimPowerSystems blocks arranged by library.

Use the Simulink Library Browser or the SimPowerSystems library to access the blocks directly, guided by this hierarchical library list.

The main SimPowerSystems **powerlib** library window contains the Powergui block that opens a graphical user interface for the steady-state analysis of electrical circuits.

Electrical Sources Library

Contains blocks that generate electric signals.

Elements Library

Contains linear and nonlinear circuit elements.

Power Electronics Library

Contains power electronics devices.

Machines Library

Contains power machinery models.

Measurements Library

Contains blocks for the current and voltage measurements.

The **Applications Libraries** icon in the **powerlib** library window lets you access the **Electric Drives Library**, the **FACTS Library**, and the **DR Library**, described below.

Electric Drives Library

Contains AC and DC electric drives models.

Flexible AC Transmission Systems (FACTS) Library

Contains the FACTS models.

Distributed Resources (DR) Library

Contains wind turbine models.

Extras Library

Contains three-phase blocks and specialized measurement and control blocks. You can also open this library by entering `powerlib_extras` at the command line.

Demos Library

Contains useful demos and case studies.

Obsolete Blocks

Contains obsolete blocks for backward compatibility.

Nonlinear Simulink Blocks for SimPowerSystems Models

The nonlinear Simulink blocks of the **powerlib** library are stored in a special block library named **powerlib_models**. These masked Simulink models are used by SimPowerSystems to build the equivalent Simulink model of your circuit. See Chapter 3, “Improving Simulation Performance” for a description of the **powerlib_models** library.

Creating Electrical Sources

AC Current Source	Implement a sinusoidal current source
AC Voltage Source	Implement a sinusoidal voltage source
Controlled Current Source	Implement a controlled current source
Controlled Voltage Source	Implement a controlled voltage source
DC Voltage Source	Implement a DC voltage source
Three-Phase Programmable Voltage Source	Implement a three-phase voltage source with programmable time variation of amplitude, phase, frequency, and harmonics
Three-Phase Source	Implement a three-phase source with internal R-L impedance

Creating Circuit Elements

Breaker	Implement a circuit breaker opening at current zero crossing
Connection Port	Create a terminal port for a subsystem
Distributed Parameter Line	Implement an N-phases distributed parameter line model with lumped losses
Ground	Provide a connection to the ground
Linear Transformer	Implement a two- or three-windings linear transformer
Multi-Winding Transformer	Implement a multi-winding transformer with taps
Mutual Inductance	Implement a magnetic coupling between two or three windings
Neutral	Implement a local common node in the circuit
Parallel RLC Branch	Implement a parallel RLC branch
Parallel RLC Load	Implement a linear parallel RLC load
PI Section Line	Implement a single-phase transmission line with lumped parameters
Saturable Transformer	Implement a two- or three-windings Saturable Transformer
Series RLC Branch	Implement a series RLC branch
Series RLC Load	Implement a linear series RLC load

Surge Arrester	Implement a metal-oxide surge arrester
Three-Phase Breaker	Implement a three-phase circuit breaker opening at current zero crossing
Three-Phase Dynamic Load	Implement a three-phase dynamic load with active power and reactive power as a function of voltage or controlled from an external input
Three-Phase Fault	Implement a programmable phase-to-phase and phase-to-ground fault breaker system
Three-Phase Harmonic Filter	Implement four types of three-phase harmonic filters using RLC components
Three-Phase Mutual Inductance Z1-Z0	Implement a three-phase RL impedance with mutual coupling between phases and allow specification in the form of positive- and zero-sequence parameters
Three-Phase Parallel RLC Branch	Implement a three-phase parallel RLC branch
Three-Phase Parallel RLC Load	Implement a three-phase parallel RLC load with selectable connection
Three-Phase PI Section Line	Implement a three-phase transmission line section with lumped parameters
Three-Phase Series RLC Branch	Implement a three-phase series RLC branch
Three-Phase Series RLC Load	Implement a three-phase series RLC load with selectable connection
Three-Phase Transformer 12 Terminals	Implement three single-phase, two-winding transformers where all terminals are accessible
Three-Phase Transformer (Two Windings)	Implement a three-phase transformer with two windings
Three-Phase Transformer (Three Windings)	Implement a three-phase transformer with three windings
Zigzag Phase-Shifting Transformer	Implement a zigzag phase-shifting transformer with secondary winding connection

Modeling Power Electronics Components

Diode	Implement a diode model
GTO	Implement a gate-turnoff (GTO) thyristor model
Ideal Switch	Implement an ideal switch model
IGBT	Implement an insulated-gate-bipolar-transistor (IGBT) model
MOSFET	Implement a metal-oxide-semiconductor-field-effect-transistor (MOSFET) model
Three-Level Bridge	Implement a three-level neutral point clamped (NPC) power converter
Thyristor	Implement a thyristor model
Universal Bridge	Implement a universal three-phase bridge converter

Modeling Electrical Machines

Asynchronous Machine	Model the dynamics of a three-phase asynchronous machine (induction machine)
DC Machine Discrete DC Machine	Model a separately excited DC machine (continuous and discrete models)
Excitation System	Provide an excitation system for the synchronous machine and regulate its terminal voltage in generating mode
Generic Power System Stabilizer	Provide a generic power system stabilizer for the synchronous machine and regulate its electrical power
Hydraulic Turbine and Governor	Model a hydraulic turbine and a proportional-integral-derivative governor system
Machine Measurement Demux	Split machine measurement signal into separate signals
Multiband Power System Stabilizer	Implement a multiband power system stabilizer
Permanent Magnet Synchronous Machine	Model the dynamics of a three-phase permanent magnet synchronous machine with sinusoidal flux distribution

Simplified Synchronous Machine	Model the dynamics of a simplified three-phase synchronous machine
Steam Turbine and Governor	Implement a steam turbine and governor system
Synchronous Machine	Model the dynamics of a three-phase round-rotor or salient-pole synchronous machine

Modeling Electric Drives

Six-Step VSI Induction Motor Drive	Implement a six-step inverter fed Induction Motor Drive
Space Vector PWM VSI Induction Motor Drive	Implement a space vector PWM VSI induction motor drive
Field-Oriented Control Induction Motor Drive	Implement a field oriented control (F.O.C.) induction motor drive model
DTC Induction Motor Drive	Implement a direct torque and flux control (DTC) induction motor drive model
Self-Controlled Synchronous Motor Drive	Implement a Self-Controlled Synchronous Motor Drive
PM Synchronous Motor Drive	Implement a Permanent Magnet Synchronous Motor drive
Two-Quadrant Single-Phase Rectifier DC Drive	Implement a two-quadrant single-phase rectifier DC drive
Four-Quadrant Single-Phase Rectifier DC Drive	Implement a single-phase dual-converter DC drive with circulating current
Two-Quadrant Three-Phase Rectifier DC Drive	Implement a two-quadrant three-phase rectifier DC drive
Four-Quadrant Three-Phase Rectifier DC Drive	Implement a three-phase dual-converter DC drive with circulating current
One-Quadrant Chopper DC Drive	Implement a one-quadrant chopper (buck converter topology) DC drive
Two-Quadrant Chopper DC Drive	Implement a two-quadrant chopper (buck-boost converter topology) DC drive

Four-Quadrant Chopper DC Drive	Implement a four-quadrant chopper DC drive.
Mechanical Shaft	Implement a mechanical shaft
Speed Reducer	Implement a speed reducer

Modeling FACTS Devices

Static Synchronous Compensator (Phasor Type)	Implement a phasor model of a three-phase static synchronous compensator (STATCOM)
Static Synchronous Series Compensator (Phasor Type)	Implement a phasor model of a three-phase static synchronous series compensator (SSSC)
Static Var Compensator (Phasor Type)	Implement a phasor model of a three-phase static var compensator
Three-Phase OLTC Phase-Shifting Transformer Delta-Hexagonal (Phasor Type)	Implement a phasor model of a three-phase OLTC phase-shifting transformer using the delta hexagonal connection
Three-Phase OLTC Regulating Transformer (Phasor Type)	Implement a phasor model of a three-phase OLTC regulating transformer
Unified Power Flow Controller (Phasor Type)	Implement a phasor model of a three-phase unified power flow controller (UPFC)

Modeling Distributed Resources Devices

Wind Turbine	Implement a model of a variable pitch wind turbine.
Wind Turbine Doubly-Fed Induction Generator (Phasor Type)	Implement a phasor model of a variable speed doubly-fed induction generator driven by a wind turbine.
Wind Turbine Induction Generator (Phasor Type)	Implement a phasor model of a squirrel-cage induction generator driven by a variable pitch wind turbine.

Measuring Electrical Circuits

Current Measurement	Measure a current in a circuit
Impedance Measurement	Measure the impedance in a circuit as a function of the frequency
Multimeter	Measure voltage and current in SimPowerSystems blocks
Three-Phase V-I Measurement	Measure three-phase currents and voltages in a circuit
Voltage Measurement	Measure a voltage in a circuit

Analyzing Electrical Circuits

Powergui	Graphical user interface for the analysis of circuits and systems
----------	---

Additional Useful Blocks

Signal Measurements

abc_to_dq0 Transformation	Perform a Park transformation from the three-phase (abc) reference frame to the dq0 reference frame
Active & Reactive Power	Measure the active and reactive powers of a voltage-current pair
dq0_to_abc Transformation	Perform a Park transformation from the dq0 reference frame to the three-phase (abc) reference frame
Fourier	Fourier analyze a signal
RMS	Measure the root mean square (RMS) value of a signal
Three-Phase Sequence Analyzer	Measure the positive-, negative-, and zero-sequence components of a three-phase signal
Total Harmonic Distortion	Measure the total harmonic distortion of a voltage or current signal containing harmonics

Signal and Pulse Sources

PWM Generator	Generate pulses for a carrier-based Pulse Width Modulator (PWM)
Synchronized 6-Pulse Generator	Implement a synchronized pulse generator to fire the thyristors of a six-pulse converter
Synchronized 12-Pulse Generator	Implement a synchronized pulse generator to fire the thyristors of a twelve-pulse converter
Timer	Generate a signal changing at specified transition times

Blocks — Alphabetical List

The following pages describe the SimPowerSystems blocks.

abc_to_dq0 Transformation

Purpose Perform a Park transformation from the three-phase (abc) reference frame to the dq0 reference frame

Library Extras/Measurements

A discrete version of this block is available in the Extras/Discrete Measurements library.

Description

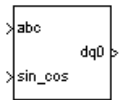

The abc_to_dq0 Transformation block computes the direct axis, quadratic axis, and zero sequence quantities in a two-axis rotating reference frame for a three-phase sinusoidal signal. The following transformation is used:

$$V_d = \frac{2}{3}(V_a \sin(\omega t) + V_b \sin(\omega t - 2\pi/3) + V_c \sin(\omega t + 2\pi/3))$$

$$V_q = \frac{2}{3}(V_a \cos(\omega t) + V_b \cos(\omega t - 2\pi/3) + V_c \cos(\omega t + 2\pi/3))$$

$$V_0 = \frac{1}{3}(V_a + V_b + V_c)$$

where ω = rotation speed (rad/s) of the rotating frame.

The transformation is the same for the case of a three-phase current; you simply replace the V_a , V_b , V_c , V_d , V_q , and V_0 variables with the I_a , I_b , I_c , I_d , I_q , and I_0 variables.

This transformation is commonly used in three-phase electric machine models, where it is known as a Park transformation. It allows you to eliminate time-varying inductances by referring the stator and rotor quantities to a fixed or rotating reference frame. In the case of a synchronous machine, the stator quantities are referred to the rotor. I_d and I_q represent the two DC currents flowing in the two equivalent rotor windings (d winding directly on the same axis as the field winding, and q winding on the quadratic axis), producing the same flux as the stator I_a , I_b , and I_c currents.

You can use this block in a control system to measure the positive-sequence component V_1 of a set of three-phase voltages or currents. The V_d and V_q (or I_d and I_q) then represent the rectangular coordinates of the positive-sequence component.

You can use the Math Function block and the Trigonometric Function block to obtain the modulus and angle of V_1 :

$$|V_1| = \sqrt{V_q^2 + V_d^2}$$

$$\angle V_1 = \text{atan2}(V_q/V_d)$$

This measurement system does not introduce any delay, but, unlike the Fourier analysis done in the Sequence Analyzer block, it is sensitive to harmonics and imbalances.

Dialog Box and Parameters

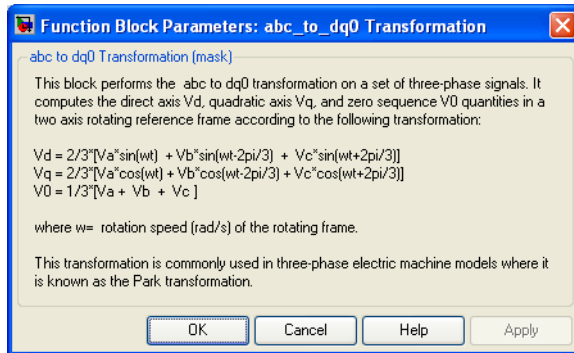

Inputs and Outputs

abc

Connect to the first input the vectorized sinusoidal phase signal to be converted [phase A phase B phase C].

sin_cos

Connect to the second input a vectorized signal containing the [sin(ωt) cos(ωt)] values, where ω is the rotation speed of the reference frame.

dq0

The output is a vectorized signal containing the three sequence components [d q o].

abc_to_dq0 Transformation

Example

The power_3phsignaldq demo uses a Discrete Three-Phase Programmable Source block to generate a 1 p.u., 15 degrees positive sequence voltage. At 0.05 second the positive sequence voltage is increased to 1.5 p.u. and at 0.1 second an imbalance is introduced by the addition of a 0.3 p.u. negative sequence component with a phase of -30 degrees. The magnitude and phase of the positive-sequence component are evaluated in two different ways:

- Sequence calculation of phasors using Fourier analysis
- abc-to-dq0 transformation

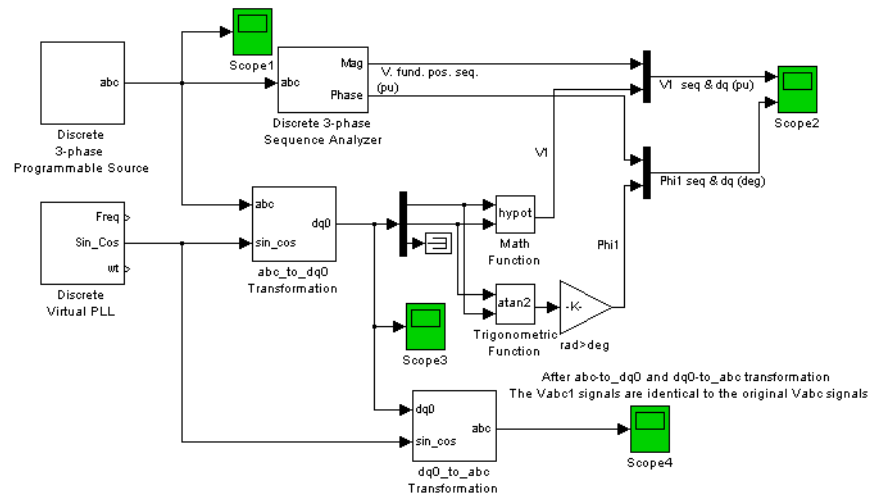

abc_to_dq0 Transformation

Start the simulation and observe the instantaneous signals V_{abc} (Scope1), the signals returned by the Sequence Analyzer (Scope2), and the abc-to-dq0 transformation (Scope3).

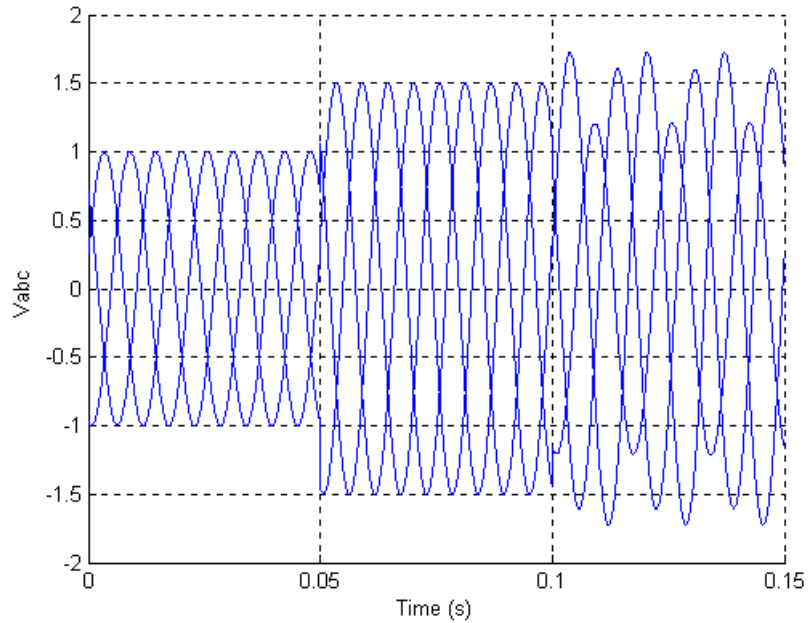

abc_to_dq0 Transformation

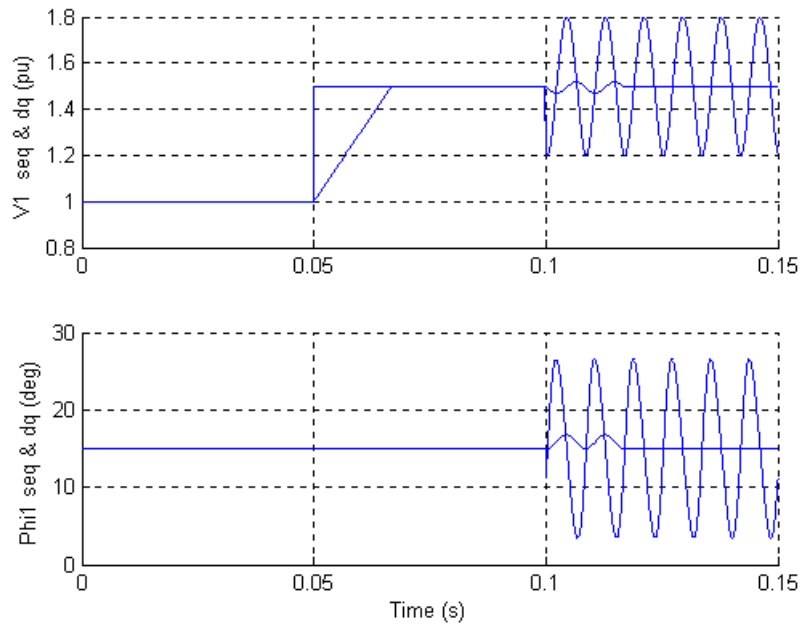

Note that the Sequence Analyzer, which uses Fourier analysis, is immune to harmonics and imbalance. However, its response to a step is a one-cycle ramp. The abc-to-dq0 transformation is instantaneous. However, an imbalance produces a ripple at the V1 and Phi1 outputs.

abc_to_dq0 Transformation

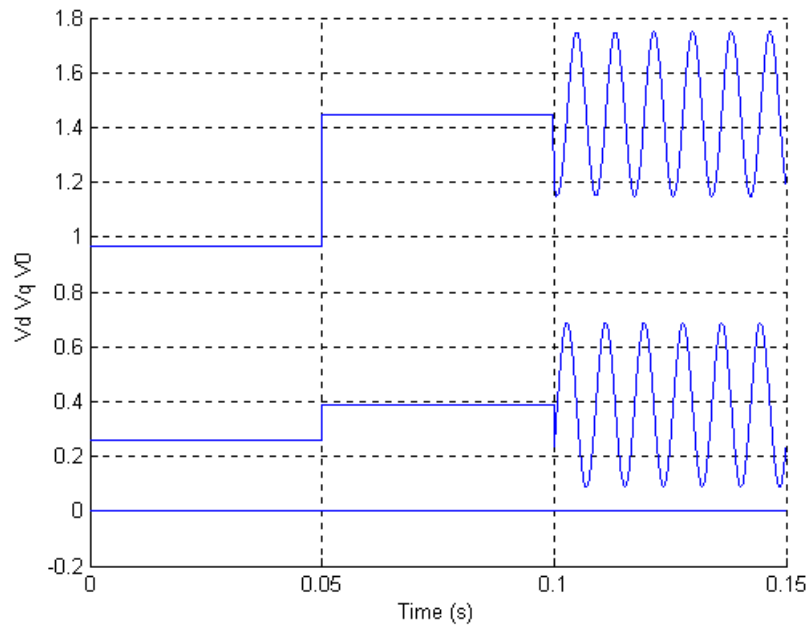

See Also

[dq0_to_abc Transformation](#)

AC Current Source

Purpose Implement a sinusoidal current source

Library Electrical Sources

Description The AC Current Source block implements an ideal AC current source. The positive current direction is indicated by the arrow in the block icon. The generated current I is described by the following relationship:



$$I = A \sin(\omega t + \phi) \quad \omega = 2\pi f \quad \phi = \text{Phase in radians}$$

Negative values are allowed for amplitude and phase. A zero frequency specifies a DC current source. You cannot enter a negative frequency; Simulink returns an error in that case, and the block displays a question mark in the block icon. You can modify the first three block parameters at any time during the simulation.

Dialog Box and Parameters

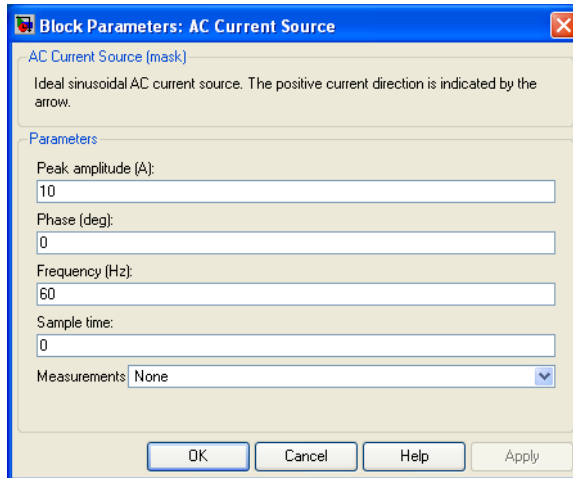

Peak amplitude

The peak amplitude of the generated current, in amperes (A).

Phase

The phase in degrees (deg). Specify a frequency of 0 and a phase of 90 degrees to implement a DC current source.

Frequency

The source frequency in hertz (Hz). Specify a frequency of 0 and a phase of 90 degrees to implement a DC current source.

Sample time

The sample period in seconds (s). The default is 0, corresponding to a continuous source.

Measurements

Select Current to measure the current flowing through the AC Current Source block.

Place a Multimeter block in your model to display the selected measurements during the simulation. In the **Available Measurements** list box of the Multimeter block, the measurement is identified by a label followed by the block name.

Measurement	Label
Current	Isrc:

Example

The power_accurent demo uses two AC Current Source blocks in parallel to sum two sinusoidal currents in a resistor.

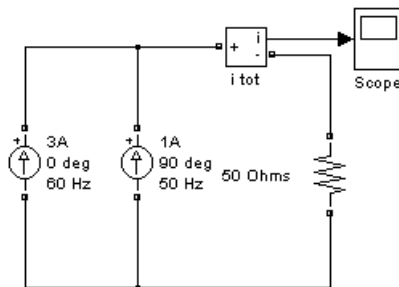

See Also

Controlled Current Source, Multimeter

Active & Reactive Power

Purpose Measure the active and reactive powers of a voltage-current pair

Library Extras/Measurements

A discrete version of this block is available in the Extras/Discrete Measurements library.

Description

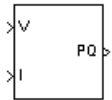

The Active & Reactive Power block measures the active power P and reactive power Q associated with a periodic voltage-current pair that can contain harmonics. P and Q are calculated by averaging the $V I$ product with a running average window over one cycle of the fundamental frequency, so that the powers are evaluated at fundamental frequency.

$$P = \frac{1}{T} \int_{(t-T)}^t (V(\omega t) \times I(\omega t)) dt$$

$$Q = \frac{1}{T} \int_{(t-T)}^t (V(\omega t) \times I(\omega t - \pi/2)) dt$$

where $T = 1/(\text{fundamental frequency})$.

A current flowing into an RL branch, for example, produces positive active and reactive powers.

As this block uses a running window, one cycle of simulation has to be completed before the output gives the correct active and reactive powers.

The discrete version of this block, available in the Extras/Discrete Measurements library, allows you to specify the initial input voltage and current (magnitude and phase). For the first cycle of simulation the outputs are held constant using the values specified by the initial input parameters.

Dialog Box and Parameters

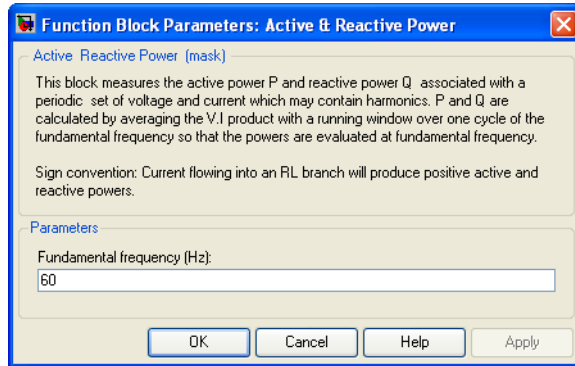

Fundamental frequency (Hz)

The fundamental frequency, in hertz, of the instantaneous voltage and current.

Inputs and Outputs

V

The first input is the instantaneous voltage.

I

The second input is the instantaneous current.

PQ

The output is a vector [P Q] of the active and reactive powers.

Example

The power_transfo demo simulates a three-winding distribution transformer rated at 75 kVA:14400/120/120 V. The transformer primary winding is connected to a high-voltage source of 14400 Vrms. Two identical inductive

Active & Reactive Power

loads (20 kW-10 kvar) are connected to the two secondary windings. A third capacitive load (30 kW-20 kvar) is fed at 240 V.

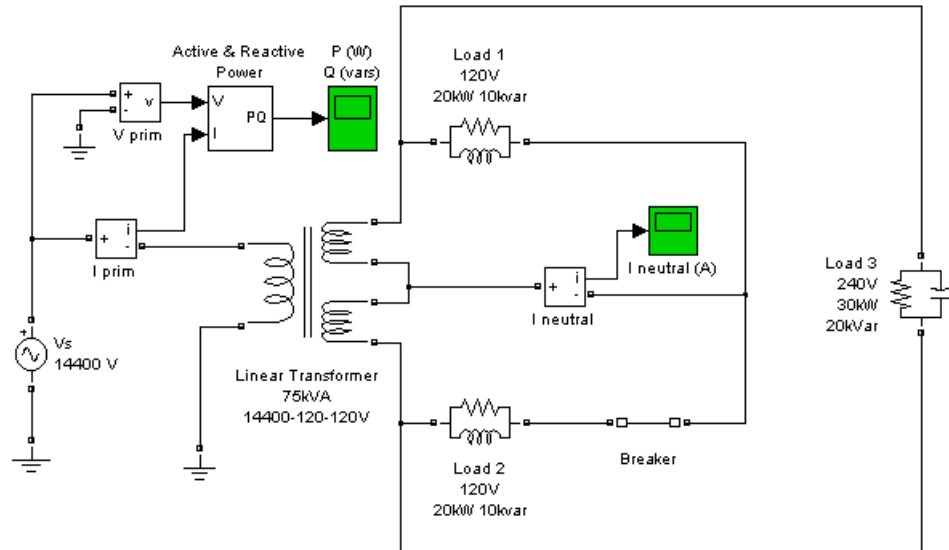

Initially, the circuit breaker in series with Load 2 is closed, so that the system is balanced. When the circuit breaker opens, a current starts to flow in the neutral path as a result of the load imbalance.

The active power computed from the primary voltage and current is measured by an Active & Reactive Power block. When the breaker opens, the active power decreases from 70 kW to 50 kW.

Active & Reactive Power

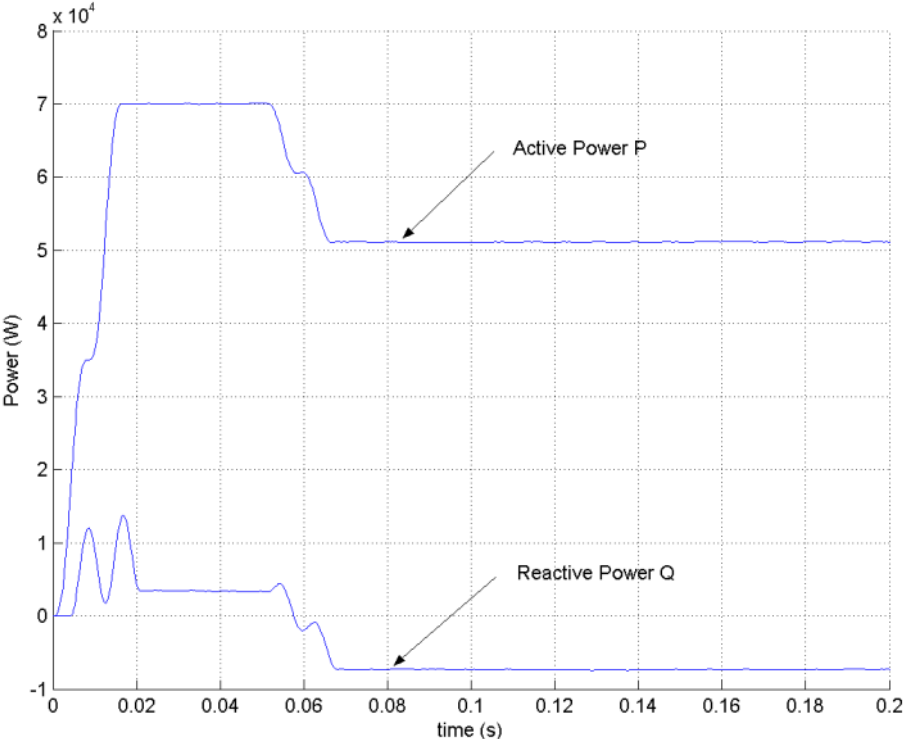

AC Voltage Source

Purpose Implement a sinusoidal voltage source

Library Electrical Sources

Description The AC Voltage Source block implements an ideal AC voltage source. The generated voltage U is described by the following relationship:



$$U = A \sin(\omega t + \phi) \quad \omega = 2\pi f \quad \phi = \text{Phase in radians}$$

Negative values are allowed for amplitude and phase. A frequency of 0 and phase equal to 90 degrees specify a DC voltage source. Negative frequency is not allowed; otherwise Simulink signals an error, and the block displays a question mark in the block icon.

Dialog Box and Parameters

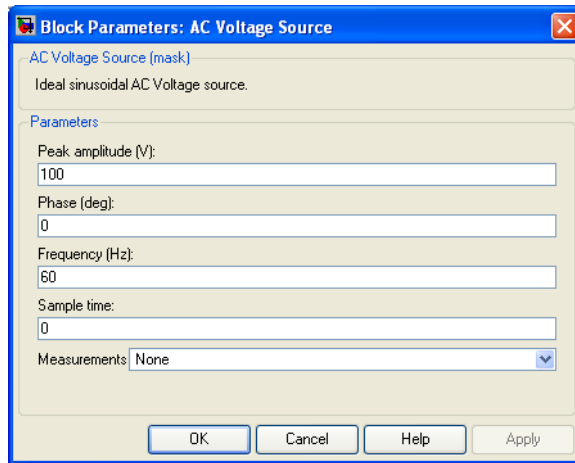

Peak amplitude

The peak amplitude of the generated voltage, in volts (V).

Phase

The phase in degrees (deg).

Frequency

The source frequency in hertz (Hz).

Sample time

The sample period in seconds (s). The default is 0, corresponding to a continuous source.

Measurements

Select **Voltage** to measure the voltage across the terminals of the AC Voltage Source block.

Place a **Multimeter** block in your model to display the selected measurements during the simulation. In the **Available Measurements** list box of the Multimeter block, the measurement is identified by a label followed by the block name.

Measurement	Label
Voltage	Usrc :

Example

The `power_acvoltage` demo uses two AC Voltage Source blocks at different frequencies connected in series across a resistor. The sum of the two voltages is read by a Voltage Measurement block.

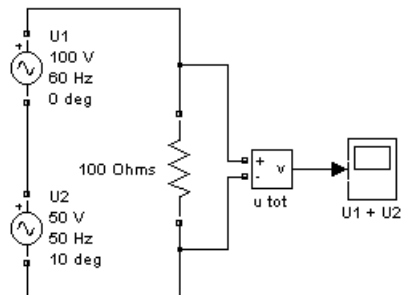

See Also

Controlled Voltage Source, DC Voltage Source, Multimeter

Asynchronous Machine

Purpose

Model the dynamics of a three-phase asynchronous machine, also known as an induction machine

Library

Machines

Description

The Asynchronous Machine block operates in either generator or motor mode. The mode of operation is dictated by the sign of the mechanical torque:

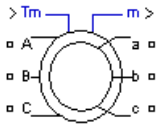

- If T_m is positive, the machine acts as a motor.
- If T_m is negative, the machine acts as a generator.

The electrical part of the machine is represented by a fourth-order state-space model and the mechanical part by a second-order system. All electrical variables and parameters are referred to the stator. This is indicated by the prime signs in the machine equations given below. All stator and rotor quantities are in the arbitrary two-axis reference frame (dq frame). The subscripts used are defined as follows:

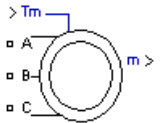

Subscript	Definition
d	d axis quantity
q	q axis quantity
r	Rotor quantity
s	Stator quantity
l	Leakage inductance
m	Magnetizing inductance

Electrical System

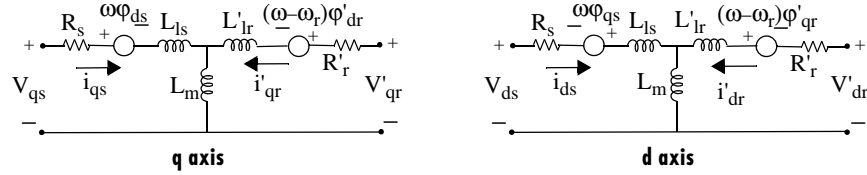

$$\begin{aligned}
 V_{qs} &= R_s i_{qs} + \frac{d}{dt} \phi_{qs} + \omega \phi_{ds} & \phi_{qs} &= L_s i_{qs} + L_m i'_{qr} \\
 V_{ds} &= R_s i_{ds} + \frac{d}{dt} \phi_{ds} - \omega \phi_{qs} & \phi_{ds} &= L_s i_{ds} + L_m i'_{dr} \\
 V'_{qr} &= R'_r i'_{qr} + \frac{d}{dt} \phi'_{qr} + (\omega - \omega_r) \phi'_{dr} & \text{where } \phi'_{qr} &= L'_r i'_{qr} + L_m i_{qs} \\
 V'_{dr} &= R'_r i'_{dr} + \frac{d}{dt} \phi'_{dr} - (\omega - \omega_r) \phi'_{qr} & \phi'_{dr} &= L'_r i'_{dr} + L_m i_{ds} \\
 T_e &= 1.5p(\phi_{ds} i_{qs} - \phi_{qs} i_{ds}) & L_s &= L_{ls} + L_m \\
 & & L'_r &= L'_{lr} + L_m
 \end{aligned}$$

Mechanical System

$$\begin{aligned}
 \frac{d}{dt} \omega_m &= \frac{1}{2H} (T_e - F \omega_m - T_m) \\
 \frac{d}{dt} \theta_m &= \omega_m
 \end{aligned}$$

The Asynchronous Machine block parameters are defined as follows (all quantities are referred to the stator):

Parameter	Definition
R_s, L_{ls}	Stator resistance and leakage inductance
R'_r, L'_{lr}	Rotor resistance and leakage inductance
L_m	Magnetizing inductance
L_s, L'_r	Total stator and rotor inductances

Asynchronous Machine

Parameter	Definition (Continued)
V_{qs}, i_{qs}	q axis stator voltage and current
V'_{qr}, i'_{qr}	q axis rotor voltage and current
V_{ds}, i_{ds}	d axis stator voltage and current
V'_{dr}, i'_{dr}	d axis rotor voltage and current
ϕ_{qs}, ϕ_{ds}	Stator q and d axis fluxes
ϕ'_{qr}, ϕ'_{dr}	Rotor q and d axis fluxes
ω_m	Angular velocity of the rotor
θ_m	Rotor angular position
p	Number of pole pairs
ω_r	Electrical angular velocity ($\omega_m \times p$)
θ_r	Electrical rotor angular position ($\theta_m \times p$)
T_e	Electromagnetic torque
T_m	Shaft mechanical torque
J	Combined rotor and load inertia coefficient. Set to infinite to simulate locked rotor.
H	Combined rotor and load inertia constant. Set to infinite to simulate locked rotor.
F	Combined rotor and load viscous friction coefficient

Dialog Box and Parameters

You can choose between two Asynchronous Machine blocks to specify the electrical and mechanical parameters of the model, by using the pu Units dialog box or the SI dialog box. Both blocks are modeling the same asynchronous machine model. Depending on the dialog box you choose to use, SimPowerSystems automatically converts the parameters you enter into per unit parameters. The Simulink model of the Asynchronous Machine block uses p.u. parameters.

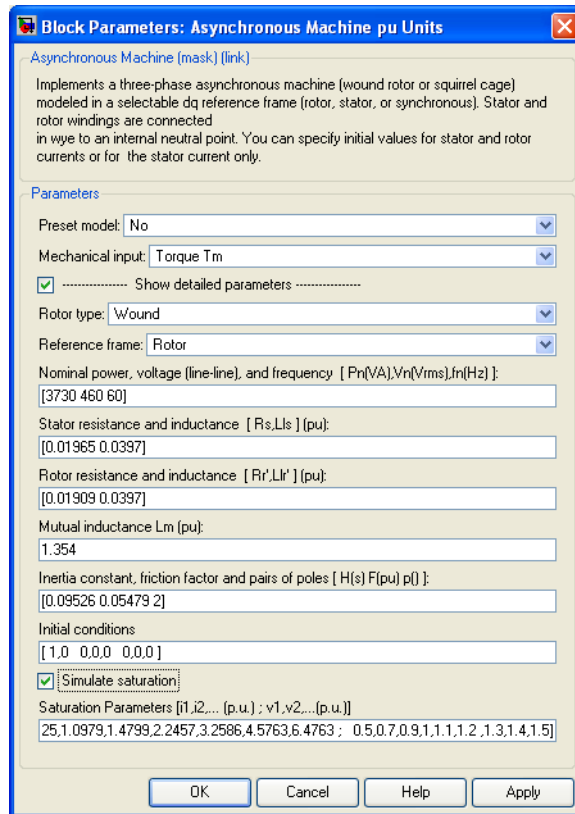

Preset model

Provides a set of predetermined electrical and mechanical parameters for various asynchronous machine ratings of power (HP), phase-to-phase voltage (V), frequency (Hz), and rated speed (rpm).

Asynchronous Machine

Select one of the preset models to load the corresponding electrical and mechanical parameters in the entries of the dialog box. Select No if you don't want to use a preset model. Note that the preset models do not include predetermined saturation parameters.

Select the **Show detailed parameters** parameter to view and edit the detailed parameters associated with the preset model.

Mechanical input

Allows you to select either the torque applied to the shaft or the rotor speed as the Simulink signal applied to the block's input.

Select **Torque T_m** to specify a torque input, in N.m or in p.u., and change labeling of the block's input to T_m . The machine speed is determined by the machine Inertia J (or inertia constant H for the p.u. machine) and by the difference between the applied mechanical torque T_m and the internal electromagnetic torque T_e . The sign convention for the mechanical torque is the following: when the speed is positive, a positive torque signal indicates motor mode and a negative signal indicates generator mode.

Select **Speed w** to specify a speed input, in rad/s or in p.u., and change labeling of the block's input to w . The machine speed is imposed and the mechanical part of the model (Inertia J) is ignored. Using the speed as the mechanical input allows modeling a mechanical coupling between two machines and interfacing with SimMechanics and SimDriveline.

The next figure indicates how to model a stiff shaft interconnection in a motor-generator. The speed output of machine 1 (motor) is connected to the speed input of machine 2 (generator), while machine 2 electromagnetic torque output T_e is applied to the mechanical torque input T_m of machine 1. The K_w factor takes into account speed units of both machines (pu or rad/s) and gear box ratio. The K_T factor takes into account torque units of both machines (pu or N.m) and machine ratings. Also, as the inertia J_2 is ignored in machine 2, J_2 referred to machine 1 speed must be added to machine 1 inertia J_1 .

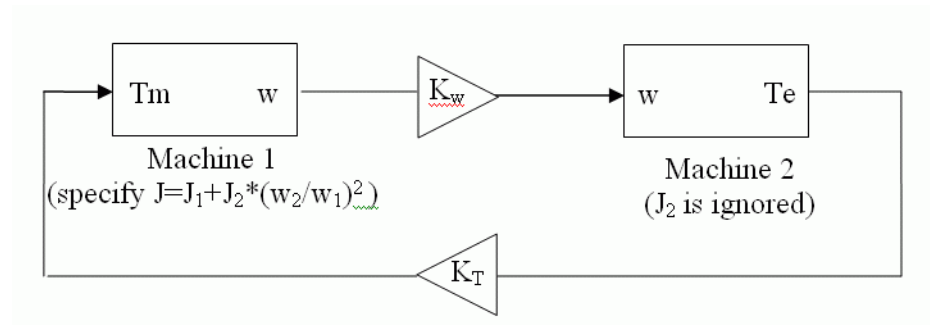

Show detailed parameters

If selected, the mask displays the detailed parameters of the Asynchronous Machine block. The detailed parameters can be modified no matter the preset model you selected in the **Preset Model** list.

Rotor type

Specifies the branching for the rotor windings.

Reference frame

Specifies the reference frame that is used to convert input voltages (abc reference frame) to the dq reference frame, and output currents (dq reference frame) to the abc reference frame. You can choose among the following reference frame transformations:

- Rotor (Park transformation)
- Stationary (Clarke or $\alpha\beta$ transformation)
- Synchronous

The following relationships describe the abc-to-dq reference frame transformations applied to the Asynchronous Machine phase-to-phase voltages.

$$\begin{bmatrix} V_{qs} \\ V_{ds} \end{bmatrix} = \frac{1}{3} \begin{bmatrix} 2 \cos \theta & \cos \theta + \sqrt{3} \sin \theta \\ 2 \sin \theta & \sin \theta - \sqrt{3} \cos \theta \end{bmatrix} \begin{bmatrix} V_{abs} \\ V_{bcs} \end{bmatrix}$$

$$\begin{bmatrix} V'_{qr} \\ V'_{dr} \end{bmatrix} = \frac{1}{3} \begin{bmatrix} 2 \cos \beta & \cos \beta + \sqrt{3} \sin \beta \\ 2 \sin \beta & \sin \beta - \sqrt{3} \cos \beta \end{bmatrix} \begin{bmatrix} V'_{abr} \\ V'_{bcr} \end{bmatrix}$$

Asynchronous Machine

In the preceding equations, θ is the angular position of the reference frame, while $\beta = \theta - \theta_r$ is the difference between the position of the reference frame and the position (electrical) of the rotor. Because the machine windings are connected in a three-wire Y configuration, there is no homopolar (0) component. This also justifies the fact that two line-to-line input voltages are used inside the model instead of three line-to-neutral voltages. The following relationships describe the dq-to-abc reference frame transformations applied to the Asynchronous Machine phase currents.

$$\begin{bmatrix} i_{as} \\ i_{bs} \end{bmatrix} = \begin{bmatrix} \cos \theta & \sin \theta \\ \frac{-\cos \theta + \sqrt{3} \sin \theta}{2} & \frac{-\sqrt{3} \cos \theta - \sin \theta}{2} \end{bmatrix} \begin{bmatrix} i_{qs} \\ i_{ds} \end{bmatrix}$$

$$\begin{bmatrix} i'_{ar} \\ i'_{br} \end{bmatrix} = \begin{bmatrix} \cos \beta & \sin \beta \\ \frac{-\cos \beta + \sqrt{3} \sin \beta}{2} & \frac{-\sqrt{3} \cos \beta - \sin \beta}{2} \end{bmatrix} \begin{bmatrix} i'_{qr} \\ i'_{dr} \end{bmatrix}$$

$$i_{cs} = -i_{as} - i_{bs}$$

$$i'_{cr} = -i'_{ar} - i'_{br}$$

The following table shows the values taken by θ and β in each reference frame (θ_e is the position of the synchronously rotating reference frame).

Reference Frame	θ	β
Rotor	θ_r	0
Stationary	0	$-\theta_r$
Synchronous	θ_e	$\theta_e - \theta_r$

The choice of reference frame affects the waveforms of all dq variables. It also affects the simulation speed and in certain cases the accuracy of the results. The following guidelines are suggested in [1]:

- Use the stationary reference frame if the stator voltages are either unbalanced or discontinuous and the rotor voltages are balanced (or 0).

- Use the rotor reference frame if the rotor voltages are either unbalanced or discontinuous and the stator voltages are balanced.
- Use either the stationary or synchronous reference frames if all voltages are balanced and continuous.

Nominal power, L-L volt, and freq.

The nominal apparent power P_n (VA), RMS line-to-line voltage V_n (V), and frequency f_n (Hz).

Stator

The stator resistance R_s (Ω or p.u.) and leakage inductance L_{ls} (H or p.u.).

Rotor

The rotor resistance R_r' (Ω or p.u.) and leakage inductance L_{lr}' (H or p.u.), both referred to the stator.

Mutual inductance

The magnetizing inductance L_m (H or p.u.).

Inertia, friction factor, and pairs of poles

For the **SI units** dialog box: the combined machine and load inertia coefficient J ($\text{kg}\cdot\text{m}^2$), combined viscous friction coefficient F (N.m.s), and pole pairs p . The friction torque T_f is proportional to the rotor speed ω ($T_f = F\cdot\omega$).

For the **p.u. units** dialog box: the inertia constant H (s), combined viscous friction coefficient F (p.u.), and pole pairs p .

Initial conditions

Specifies the initial slip s , electrical angle θ_e (degrees), stator current magnitude (A or p.u.), and phase angles (degrees):

[slip, θ_e , i_{as} , i_{bs} , i_{cs} , phase_{as} , phase_{bs} , phase_{cs}]

For the wound-rotor machine, you can also specify optional initial values for the rotor current magnitude (A or p.u.), and phase angles (degrees):

[slip, θ_e , i_{as} , i_{bs} , i_{cs} , phase_{as} , phase_{bs} , phase_{cs} , i_{ar} , i_{br} , i_{cr} , phase_{ar} , phase_{br} , phase_{cr}]

For the squirrel cage machine, the initial conditions can be computed by the load flow utility in the Powergui block.

Asynchronous Machine

Simulate saturation

Specifies whether magnetic saturation of rotor and stator iron is simulated or not.

Saturation parameters

Specifies the no-load saturation curve parameters. Magnetic saturation of stator and rotor iron (saturation of the mutual flux) is modeled by a nonlinear function (in this case a polynomial) using points of the no-load saturation curve. You must enter a 2-by-n matrix, where n is the number of points taken from the saturation curve. The first row of this matrix contains the values of stator currents, while the second row contains values of corresponding terminal voltages (stator voltages). The first point (first column of the matrix) must correspond to the point where the effect of saturation begins.

You must select the **Simulate saturation** check box to simulate saturation. If the **Simulate saturation** is not selected, the relationship between the stator current and the stator voltage is linear.

Inputs and Outputs

T_m

The Simulink input of the block is the mechanical torque at the machine's shaft. When the input is a positive Simulink signal, the asynchronous machine behaves as a motor. When the input is a negative signal, the asynchronous machine behaves as a generator.

When you use the SI parameters mask, the input is a signal in N.m, otherwise it is in p.u.

m

The Simulink output of the block is a vector containing 21 signals. You can demultiplex these signals by using the Bus Selector block provided in the Simulink library. Depending on the type of mask you use, the units are in SI, or in p.u.

Signal	Definition	Units	Symbol
1	Rotor current i_{r_a}	A or p.u.	i'_{ra}
2	Rotor current i_{r_b}	A or p.u.	i'_{rb}

Asynchronous Machine

Signal	Definition	Units	Symbol
3	Rotor current i_{r_c}	A or p.u.	i'_{rc}
4	Rotor current i_q	A or p.u.	i'_{qr}
5	Rotor current i_d	A or p.u.	i'_{dr}
6	Rotor flux ϕ_{ir_q}	V.s or p.u	ϕ'_{qr}
7	Rotor flux ϕ_{ir_d}	V.s or p.u	ϕ'_{dr}
8	Rotor voltage V_{r_q}	V or p.u	v'_{qr}
9	Rotor voltage V_{r_d}	V or p.u	v'_d
10	Stator current i_{s_a}	A or p.u.	i_{sa}
11	Stator current i_{s_b}	A or p.u.	i_{sb}
12	Stator current i_{s_c}	A or p.u.	i_{sc}
13	Stator current i_{s_q}	A or p.u.	i_{qs}
14	Stator current i_{s_d}	A or p.u.	i_{ds}
15	Stator flux ϕ_{is_q}	V.s or p.u.	ϕ_{qs}
16	Stator flux ϕ_{is_d}	V.s or p.u.	ϕ_{ds}
17	Stator voltage v_{s_q}	V or p.u.	v_{qs}
18	Stator voltage v_{s_d}	V or p.u.	v_{ds}
19	Rotor speed	rad/s	ω_m
20	Electromagnetic torque T_e	N.m or p.u.	T_e
21	Rotor angle θ_{m}	rad	θ_m

The stator terminals of the Asynchronous Machine block are identified by the A, B, and C letters. The rotor terminals are identified by the a, b, and c letters. Note that the neutral connections of the stator and rotor windings are not available; three-wire Y connections are assumed.

Asynchronous Machine

Limitations

- 1 The Asynchronous Machine block does not include a representation of the saturation of leakage fluxes. You must be careful when you connect ideal sources to the machine's stator. If you choose to supply the stator via a three-phase Y-connected infinite voltage source, you must use three sources connected in Y. However, if you choose to simulate a delta source connection, you must use only two sources connected in series.

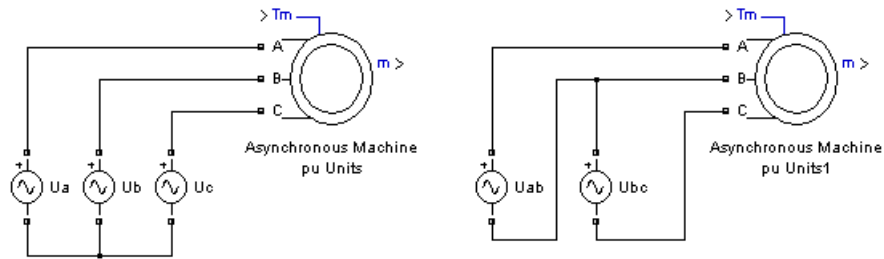

- 2 When you use Asynchronous Machine blocks in discrete systems, you might have to use a small parasitic resistive load, connected at the machine terminals, in order to avoid numerical oscillations. Large sample times require larger loads. The minimum resistive load is proportional to the sample time. As a rule of thumb, remember that with a 25 ms time step on a 60 Hz system, the minimum load is approximately 2.5% of the machine nominal power. For example, a 200 MVA asynchronous machine in a power system discretized with a 50 ms sample time requires approximately 5% of resistive load or 10 MW. If the sample time is reduced to 20 ms, a resistive load of 4 MW should be sufficient.

Examples

Example 1: Use of the Asynchronous Machine Block in Motor Mode

The `power_pwm` demo illustrates the use of the Asynchronous Machine block in motor mode. It consists of an asynchronous machine in an open-loop speed control system.

The machine's rotor is short-circuited, and the stator is fed by a PWM inverter, built with Simulink blocks and interfaced to the Asynchronous Machine block through the Controlled Voltage Source block. The inverter uses sinusoidal pulse-width modulation, which is described in [2]. The base frequency of the sinusoidal reference wave is set at 60 Hz and the triangular carrier wave's frequency is set at 1980 Hz. This corresponds to a frequency modulation factor

Asynchronous Machine

m_f of 33 ($60 \text{ Hz} \times 33 = 1980$). It is recommended in [2] that m_f be an odd multiple of three and that the value be as high as possible.

The 3 HP machine is connected to a constant load of nominal value (11.9 N.m). It is started and reaches the set point speed of 1.0 p.u. at $t = 0.9$ second.

The parameters of the machine are those found in the **SI Units** dialog box above, except for the stator leakage inductance, which is set to twice its normal value. This is done to simulate a smoothing inductor placed between the inverter and the machine. Also, the stationary reference frame was used to obtain the results shown.

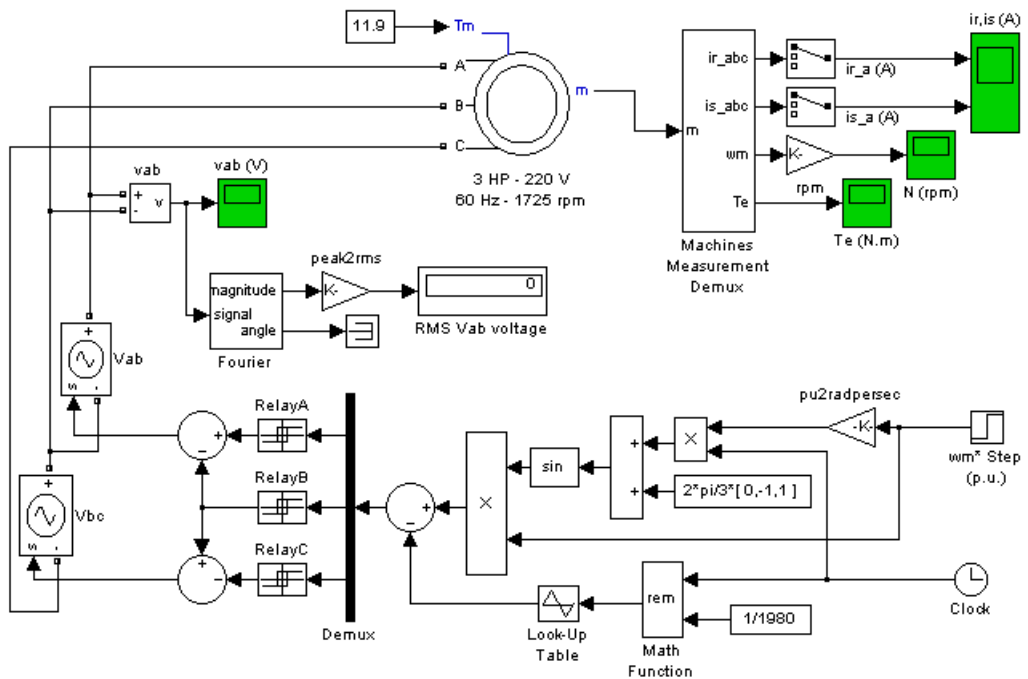

Open the power_pwm demo. Note in the simulation parameters that a small relative tolerance is required because of the high switching rate of the inverter.

Run the simulation and observe the machine's speed and torque.

Asynchronous Machine

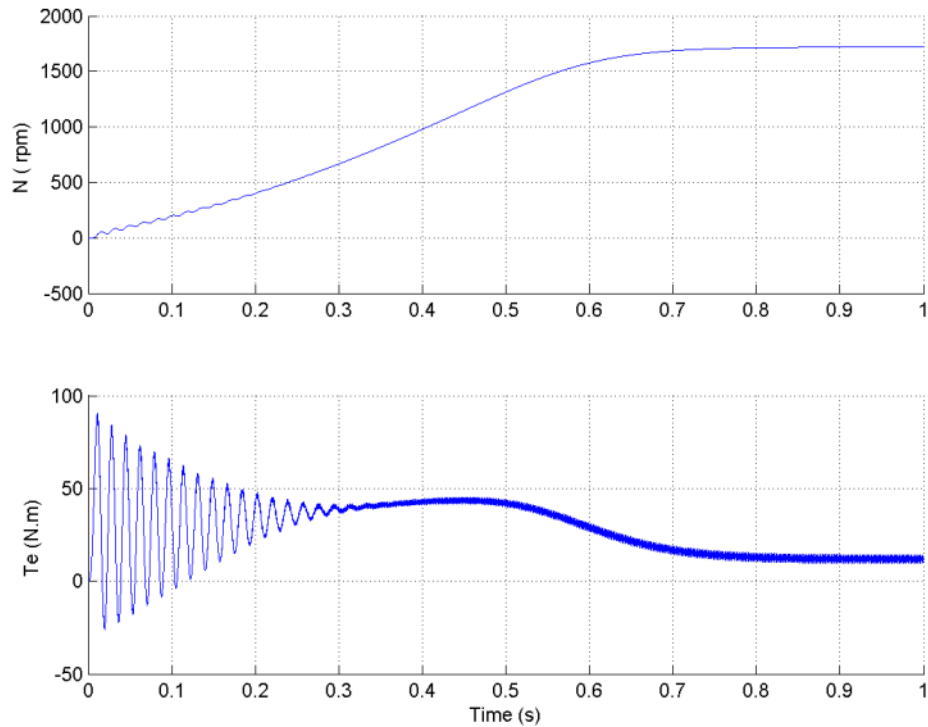

The first graph shows the machine's speed going from 0 to 1725 rpm (1.0 p.u.). The second graph shows the electromagnetic torque developed by the machine. Because the stator is fed by a PWM inverter, a noisy torque is observed.

However, this noise is not visible in the speed because it is filtered out by the machine's inertia, but it can also be seen in the stator and rotor currents, which are observed next.

Asynchronous Machine

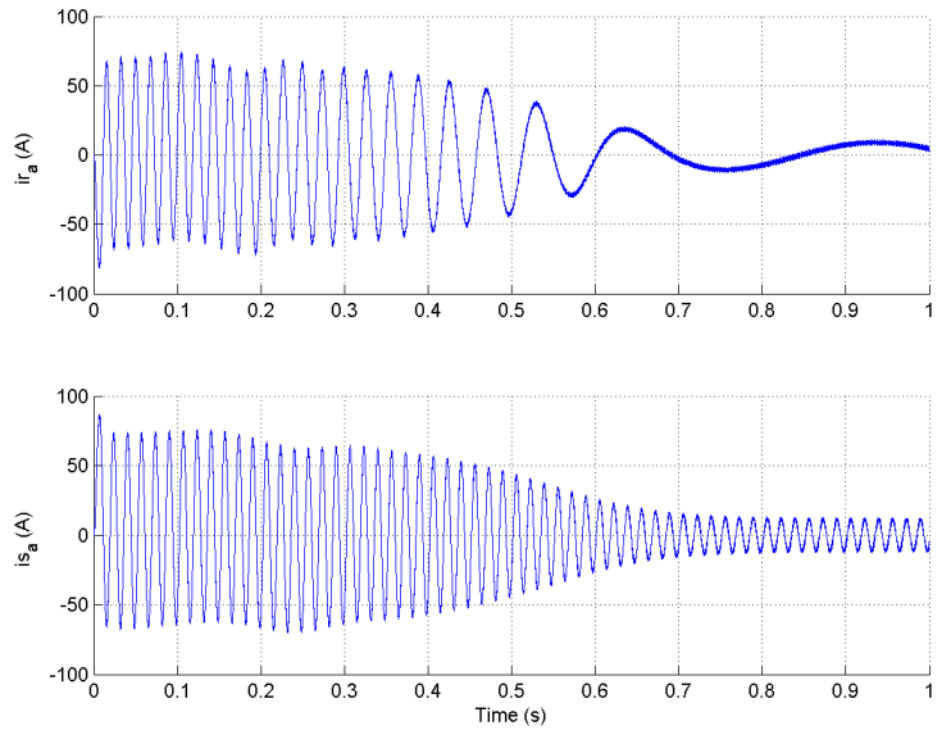

Finally, look at the output of the PWM inverter. Because nothing of interest can be seen at the simulation time scale, the graph concentrates on the last moments of the simulation.

Asynchronous Machine

2

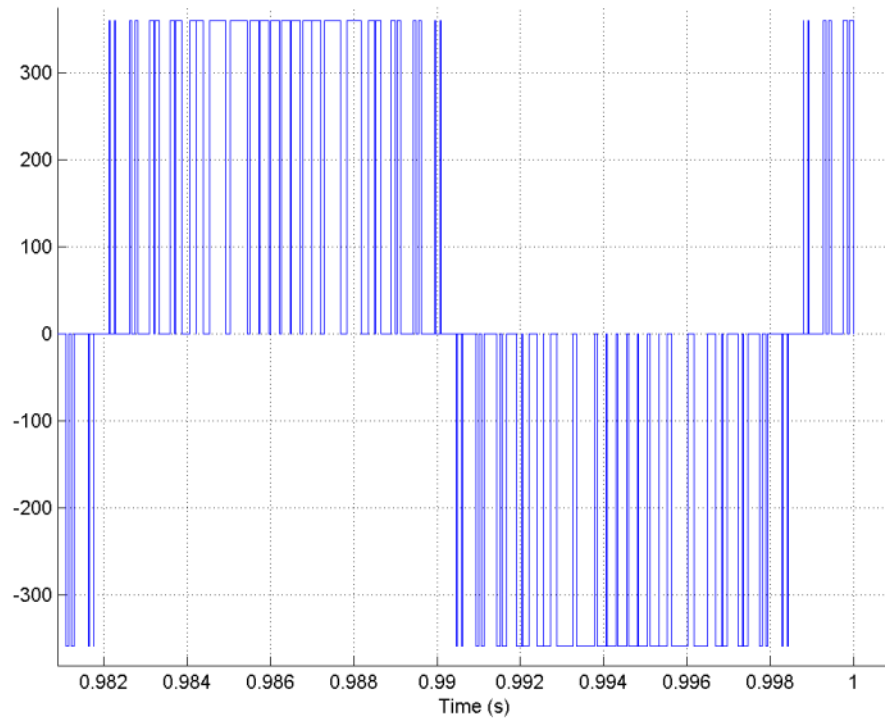

Example 2: Effect of Saturation of the Asynchronous Machine Block

The `power_asm_sat` demo illustrates the effect of saturation of the Asynchronous Machine block.

Two identical three-phase motors (50 HP, 460 V, 1800 rpm) are simulated with and without saturation, to observe the saturation effects on the stator currents. Two different simulations are realized in the demo.

Asynchronous Machine

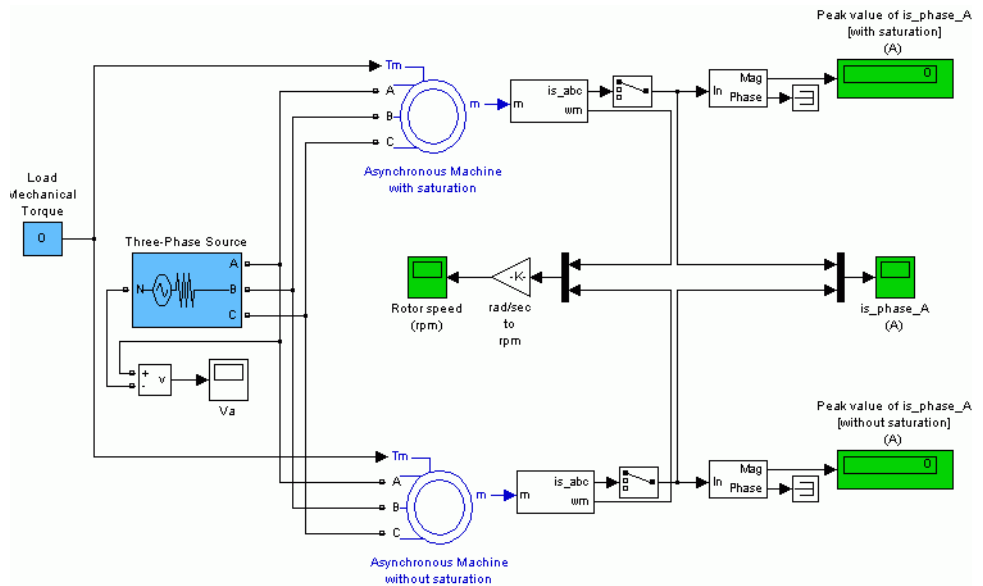

The first simulation, is the no-load steady-state test. The table below contains the values of the **Saturation Parameters** and the measurements obtained by simulating different operating points on the saturated motor (no-load and in steady-state).

Saturation Parameters		Measurements	
V _{sat} (V _{rms} L-L)	I _{sat} (peak A)	V _{rms} L-L	I _s A (peak A)
-	-	120	7.322
230	14.04	230	14.03
-	-	250	16.86
-	-	300	24.04
322	27.81	322	28.39
-	-	351	35.22
-	-	382	43.83
414	53.79	414	54.21
-	-	426	58.58
-	-	449	67.94
460	72.69	460	73.01

Asynchronous Machine

Saturation Parameters		Measurements	
Vsat (Vrms L-L)	Isat (peak A)	Vrms L-L	Is_A (peak A)
-	-	472	79.12
-	-	488	88.43
506	97.98	506	100.9
-	-	519	111.6
-	-	535	126.9
-	-	546	139.1
552	148.68	552	146.3
-	-	569	169.1
-	-	581	187.4
598	215.74	598	216.5
-	-	620	259.6
-	-	633	287.8
644	302.98	644	313.2
-	-	659	350
-	-	672	383.7
-	-	681	407.9
690	428.78	690	432.9

The graph below illustrates these results and shows the accuracy of the saturation model. As you can see, the measured operating points fit well the curve that is plotted from the **Saturation Parameters** data.

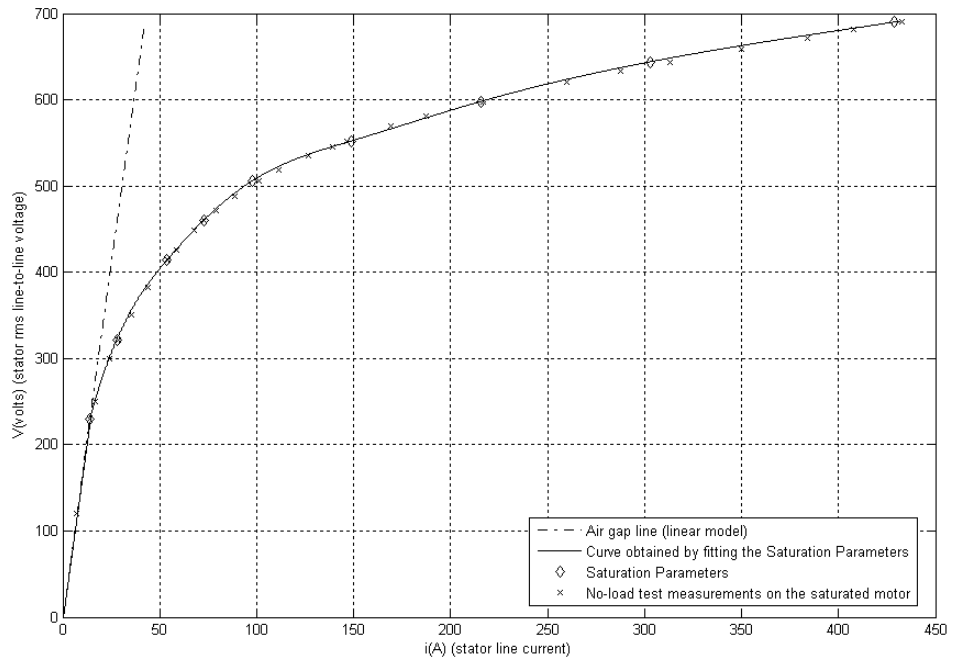

Running the simulation with a blocked rotor or with many different values of load torque will allow the observation of other effects of saturation on the stator currents.

References

- [1] Krause, P.C., O. Wasynczuk, and S.D. Sudhoff, *Analysis of Electric Machinery*, IEEE Press, 2002.
- [2] Mohan, N., T.M. Undeland, and W.P. Robbins, *Power Electronics: Converters, Applications, and Design*, John Wiley & Sons, Inc., New York, 1995, Section 8.4.1.

See Also

Powergui

Breaker

Purpose

Implement a circuit breaker opening at the current zero crossing

Library

Elements

Description

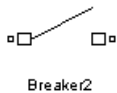
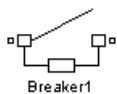
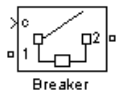

The Breaker block implements a circuit breaker where the opening and closing times can be controlled either from an external Simulink signal (external control mode), or from an internal control timer (internal control mode).

The arc extinction process is simulated by opening the breaker device when the current passes through 0 (first current zero crossing following the transition of the Simulink control input from 1 to 0).

When the breaker is closed it behaves as a resistive circuit. It is represented by a resistance R_{on} . The R_{on} value can be set as small as necessary in order to be negligible compared with external components (typical value is 10 m Ω). When the breaker is open it has an infinite resistance.

If the Breaker block is set in external control mode, a Simulink input appears on the block icon. The control signal connected to the Simulink input must be either 0 or 1: 0 to open the breaker, 1 to close it. If the Breaker block is set in internal control mode, the switching times are specified in the dialog box of the block.

If the breaker initial state is set to 1 (closed), SimPowerSystems automatically initializes all the states of the linear circuit and the Breaker block initial current so that the simulation starts in steady state.

A series Rs-Cs snubber circuit is included in the model. It can be connected to the circuit breaker. If the Breaker block happens to be in series with an inductive circuit, an open circuit or a current source, you must use a snubber.

Dialog Box and Parameters

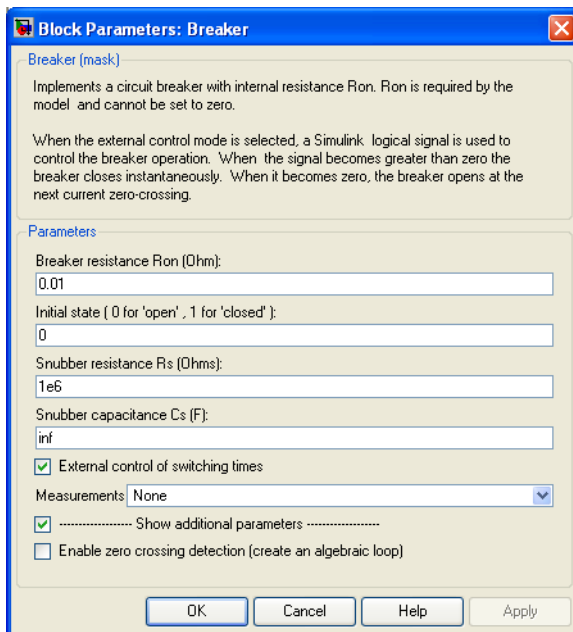

Breaker resistance R_{on}

The internal breaker resistance, in ohms (Ω). The **Breaker resistance R_{on}** parameter cannot be set to 0.

Initial state

The initial state of the breaker. A closed contact is displayed in the block icon when the **Initial state** parameter is set to 1, and an open contact is displayed when it is set to 0.

Snubber resistance R_s

The snubber resistance, in ohms (Ω). Set the **Snubber resistance R_s** parameter to `inf` to eliminate the snubber from the model.

Snubber capacitance C_s

The snubber capacitance, in farads (F). Set the **Snubber capacitance C_s** parameter to 0 to eliminate the snubber, or to `inf` to get a resistive snubber.

Breaker

Switching times

Specifies the vector of switching times when using the Breaker block in internal control mode. At each switching time the Breaker block opens or closes depending on its initial state. For example, if the **Initial state** parameter is 0 (open), the breaker closes at the first switching time, opens at the second switching time, and so on. The **Switching times** parameter is not visible in the dialog box if the **External control of switching times** parameter is selected.

External control of switching times

If selected, adds a Simulink input to the Breaker block for external control of the switching times of the breaker. The switching times are defined by a logical signal (0 or 1) connected to the Simulink input.

Measurements

Select Branch voltage to measure the voltage across the Breaker block terminals.

Select Branch current to measure the current flowing through the Breaker block. If the snubber device is connected to the breaker model, the measured current is the one flowing through the breaker contacts only.

Select Branch voltage and current to measure the breaker voltage and the breaker current.

Place a Multimeter block in your model to display the selected measurements during the simulation.

In the **Available Measurements** list box of the Multimeter block, the measurement is identified by a label followed by the block name:

Measurement	Label
Branch voltage	Ub :
Branch current	Ib :

Limitations

When the block is connected in series with an inductor or another current source, you must add the snubber circuit. In most applications you can use a resistive snubber (**Snubber capacitance** parameter set to ∞) with a large

resistor value (**Snubber resistance** parameter set to 1e6 or so). Because of modeling constraints, the internal breaker inductance R_{on} cannot be set to 0.

You must use a stiff integration algorithm to simulate circuits with the Breaker block. ode23t with default parameters usually gives the best simulation speed.

Example

The power_breaker demo illustrates a circuit breaker connected in series with a series RL circuit on a 60 Hz voltage source. The switching times of the Breaker block are controlled by a Simulink signal. The breaker device is initially closed and an opening order is given at $t = 1.5$ cycles, when current reaches a maximum. The current stops at the next zero crossing, then the breaker is reclosed at a zero crossing of voltage at $t = 3$ cycles.

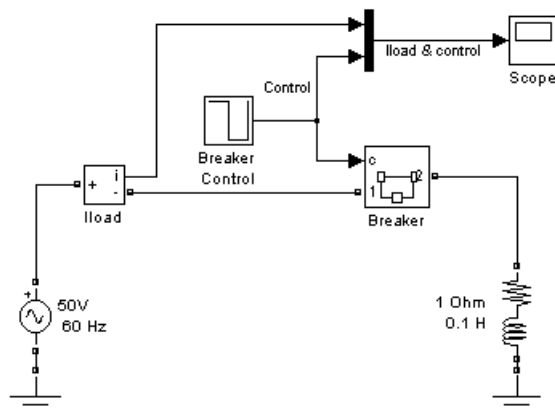

Breaker

Simulation produces the following results.

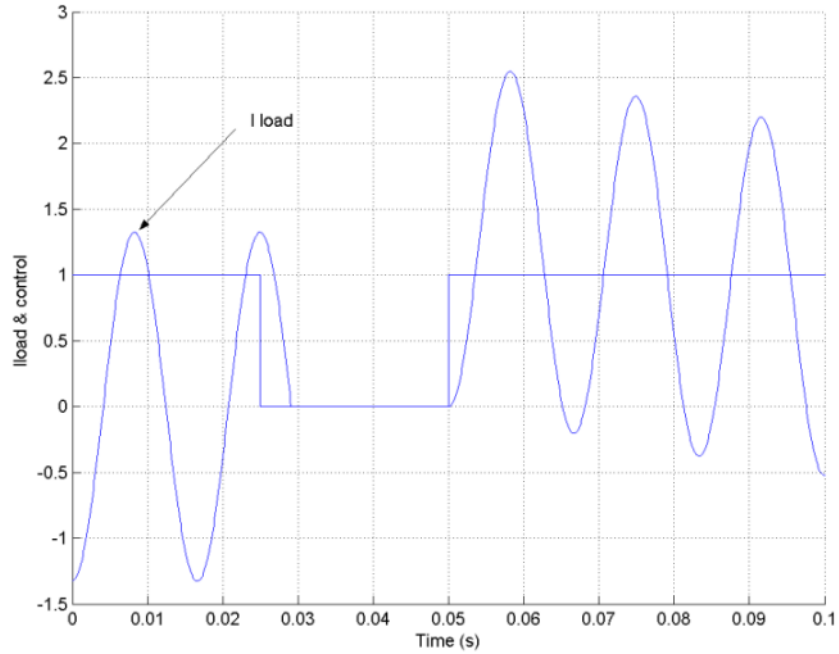

Note that the breaker device opens only when the load current has reached zero, after the opening order.

See Also

Three-Phase Fault

Purpose Create a Physical Modeling connector port for a subsystem

Library Elements

Description



The Connection Port block, placed inside a subsystem composed of SimPowerSystems blocks, creates a Physical Modeling open round connector port \circ on the boundary of the subsystem. Once connected to a connection line, the port becomes solid \bullet . Once you begin the simulation, the solid port \bullet becomes an electrical terminal port, an open square \square .

You connect individual SimPowerSystems blocks and subsystems made of SimPowerSystems blocks to one another with SimPowerSystems connection lines, instead of normal Simulink signal lines. These are anchored at the open, round connector ports \circ . Subsystems constructed of SimPowerSystems blocks automatically have such open round connector ports. You can add additional connector ports by adding Connection Port blocks to your subsystem.

Dialog Box and Parameters

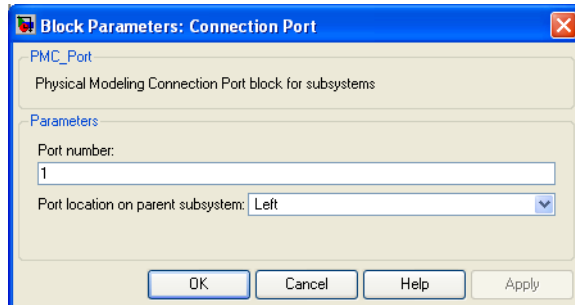

Port number

This field labels the subsystem connector port created by the block. Multiple connector ports on the boundary of a single subsystem require different numbers as labels. The default value for the first port is 1.

Port location on parent subsystem

Choose which side of the parent subsystem boundary the port is placed on. The choices are Left or Right. The default is Left.

See Also See “Creating Subsystems” in the Simulink documentation

Controlled Current Source

Purpose Implement a controlled current source

Library Electrical Sources

Description The Controlled Current Source block provides a current source controlled by a Simulink signal. The positive current direction is as shown by the arrow in the block icon.



You can initialize the Controlled Current Source block with a specific AC or DC current. If you want to start the simulation in steady state, the block input must be connected to a signal starting as a sinusoidal or DC waveform corresponding to the initial values.

Dialog Box and Parameters

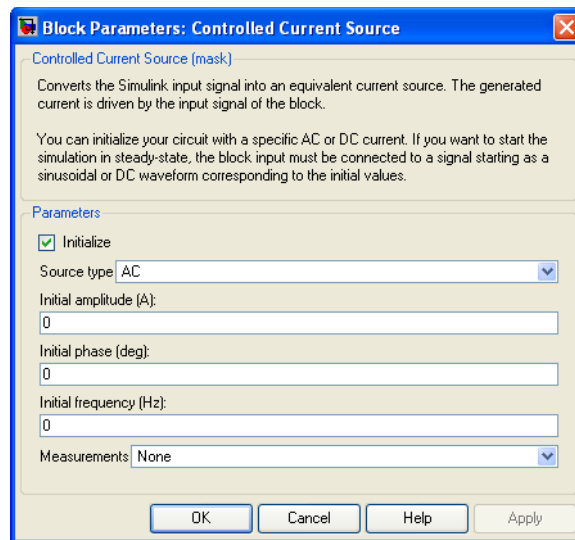

Initialize

If selected, initializes the Controlled Current Source block with the specified **Initial current**, **Initial phase**, and **Initial frequency** parameters.

Source type

The **Source type** parameter is not visible if the **Initialize** parameter is not selected.

The type of current source. Select AC to initialize the Controlled Current Source Block as an AC current source. Select DC to initialize the Controlled Current Source block as a DC current.

Initial current

The **Initial current** parameter is not visible in the dialog box if the **Initialize** parameter is not selected. The initial peak current for the initialization of the source, in amperes (A).

Initial phase

The initial phase for the initialization of the source, in degrees. The **Initial phase** parameter is not visible in the dialog box if the **Source type** parameter is set to **DC**.

Initial frequency

The initial frequency for the initialization of the source, in hertz (Hz). The **Initial frequency** parameter is not visible in the dialog box if the **Source type** parameter is set to **DC**.

Measurements

Select Current to measure the current flowing through the Controlled Current Source block.

Place a Multimeter block in your model to display the selected measurements during the simulation. In the **Available Measurements** list box of the Multimeter block, the measurement is identified by a label followed by the block name:

Measurement	Label
Current	Isrc:

Example

The `power_controlcurr` demo uses a Controlled Current Source to generate a 60 Hz current modulated at 5 Hz.

Controlled Current Source

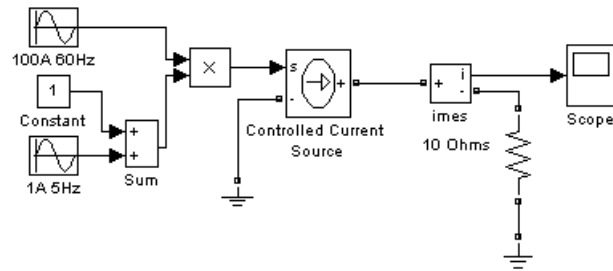

Simulation produces the following waveforms:

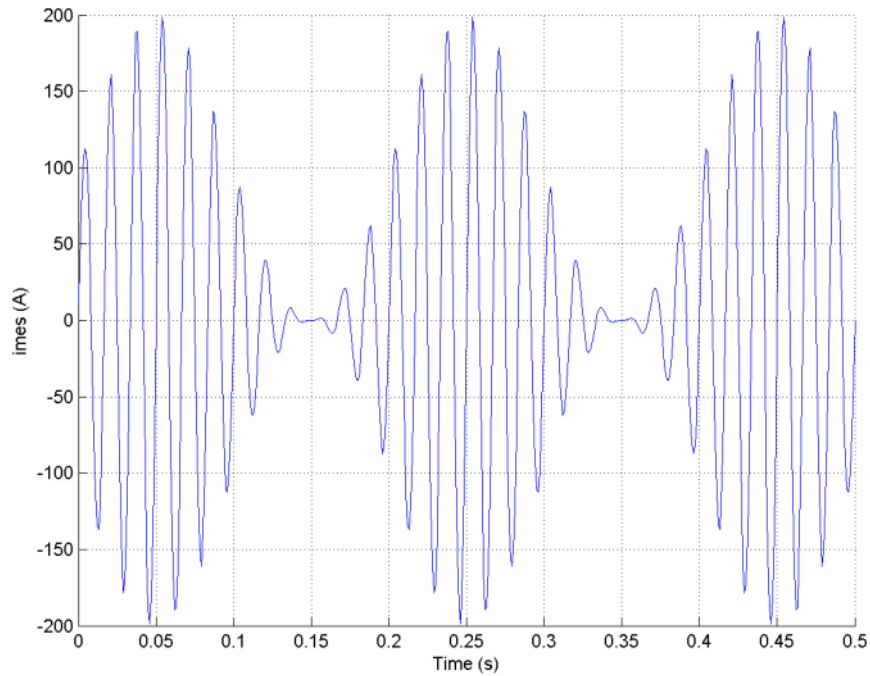

See Also

AC Current Source, Controlled Voltage Source, Multimeter

Purpose Implement a controlled voltage source

Library Electrical Sources

Description The Controlled Voltage Source block provides a voltage source controlled by a Simulink signal.



You can initialize the Controlled Voltage Source block with a specific AC or DC voltage. If you want to start the simulation in steady state, the Simulink input must be connected to a signal starting as a sinusoidal or DC waveform corresponding to the initial values.

Dialog Box and Parameters

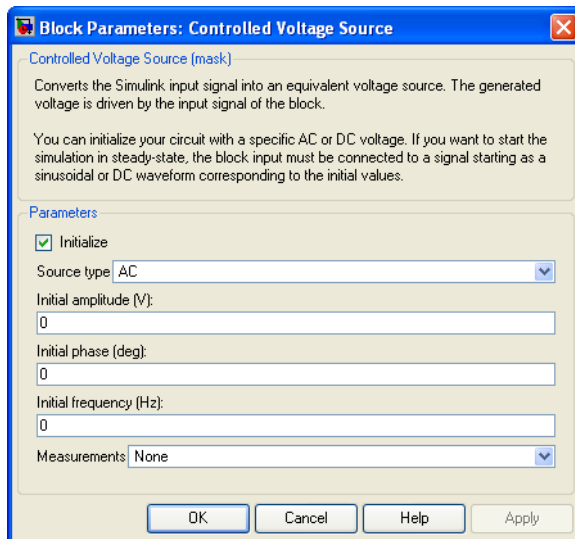

Initialize

If selected, initializes the Controlled Voltage Source block with the specified **Initial voltage**, **Initial phase**, and **Initial frequency** parameters.

Source type

The **Source type** parameter is not available if the **Initialize** parameter is not selected.

Controlled Voltage Source

The type of voltage source. Select AC to initialize the Controlled Voltage Source block with an AC voltage source. Select DC to initialize the Controlled Voltage Source Block with a DC voltage.

Initial voltage

The **Initial voltage** parameter is not available if the **Initialize** parameter is not selected. The initial voltage for the initialization of the source, in volts (V).

Initial phase

The **Initial phase** parameter is not available if the **Source type** parameter is set to **DC**. The initial phase for the initialization of the source, in degrees.

Initial frequency

The initial frequency for the initialization of the source, in hertz (Hz). The **Initial frequency** parameter is not available in the dialog box if the **Source type** parameter is set to **DC**.

Measurements

Select Voltage to measure the voltage across the terminals of the Controlled Voltage Source block.

Place a Multimeter block in your model to display the selected measurements during the simulation. In the **Available Measurements** list box of the Multimeter block, the measurement is identified by a label followed by the block name:

Measurement	Label
Voltage	Usrc:

Example

The power_controlvolt demo uses Controlled Voltage Source blocks to generate a 60 Hz sinusoidal voltage containing a third harmonic. One Controlled Voltage Source block is initialized as a 120 V AC voltage source with an initial frequency of 60 Hz and initial phase set to 0. The second Controlled Voltage Source block is not initialized.

At $t = 0.0333$ s a 100 V-180 Hz sinusoidal signal is added to the 120 V Simulink signal. The resulting capacitor voltages are compared on a Scope block.

Controlled Voltage Source

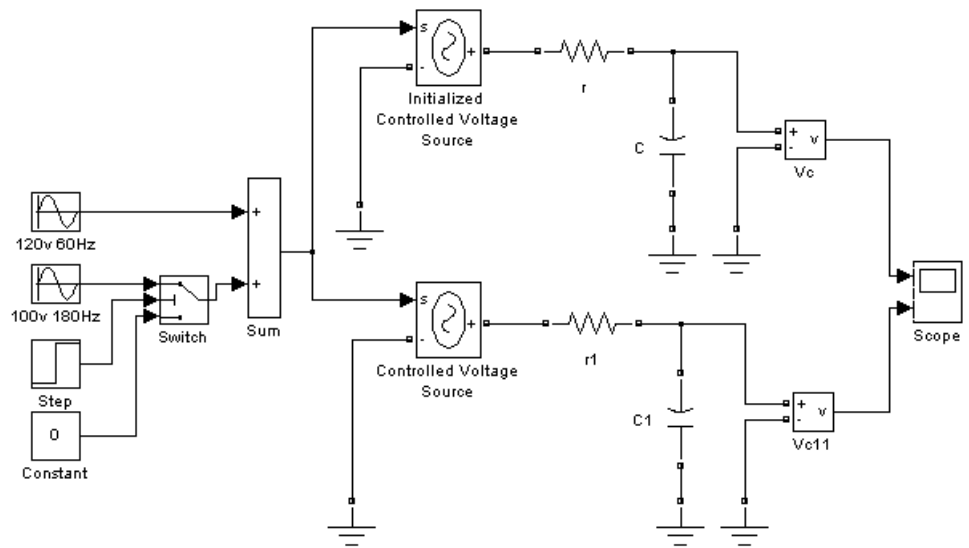

Controlled Voltage Source

The V_c voltage starts in steady state, whereas the V_{c1} voltage contains a DC offset.

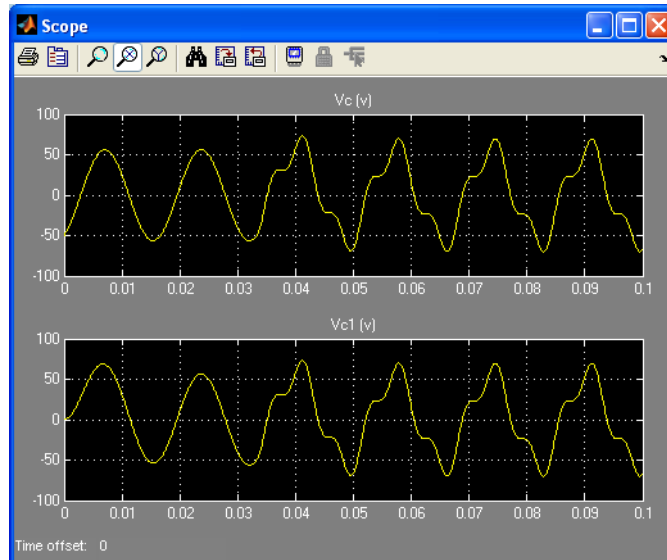

See Also

AC Current Source, Controlled Current Source, Multimeter

Purpose Measure a current in a circuit

Library Measurements

Description The Current Measurement block is used to measure the instantaneous current flowing in any electrical block or connection line. The Simulink output provides a Simulink signal that can be used by other Simulink blocks.



Dialog Box and Parameters

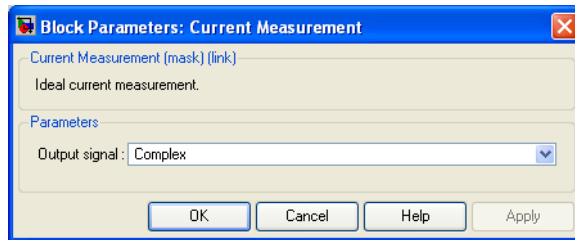

Output signal

Specifies the format of the output signal when the block is used in a phasor simulation. The **Output signal** parameter is disabled when the block is not used in a phasor simulation. The phasor simulation is activated by a Powergui block placed in the model.

Set to Complex to output the measured current as a complex value. The output is a complex signal.

Set to Real - Imag to output the real and imaginary parts of the measured current. The output is a vector of two elements.

Set to Magnitude-Angle to output the magnitude and angle of the measured current. The output is a vector of two elements.

Set to Magnitude to output the magnitude of the measured current. The output is a scalar value.

Current Measurement

Example

The power_currmeasure demo uses four Current Measurement blocks to read currents in different branches of a circuit. The two scopes display the same current.

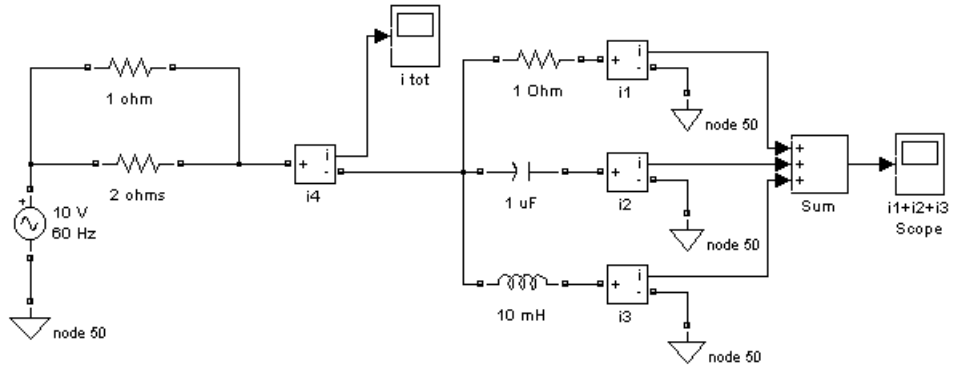

See Also

Powergui, Three-Phase V-I Measurement, Voltage Measurement

Purpose Implement a separately excited DC machine (continuous and discrete blocks)

Library Machines

Description

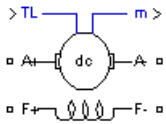

The DC Machine block and the Discrete DC Machine block (also in the Machines library) both implement a separately excited DC machine. The DC Machine block implements a continuous model, and the Discrete DC Machine block implements a discrete model. The following description applies to both blocks.

An access is provided to the field terminals (F+, F-) so that the machine model can be used as a shunt-connected or a series-connected DC machine. The torque applied to the shaft is provided at the Simulink input T_L .

The armature circuit (A+, A-) consists of an inductor L_a and resistor R_a in series with a counter-electromotive force (CEMF) E .

The CEMF is proportional to the machine speed.

$$E = K_E \omega$$

K_E is the voltage constant and ω is the machine speed.

In a separately excited DC machine model, the voltage constant K_E is proportional to the field current I_f

$$K_E = L_{af} I_f$$

where L_{af} is the field-armature mutual inductance.

The electromechanical torque developed by the DC machine is proportional to the armature current I_a .

$$T_e = K_T I_a$$

where K_T is the torque constant. The sign convention for T_e and T_L is

$$T_e T_L > 0 : \text{Motor mode}$$

$$T_e T_L < 0 : \text{Generator mode}$$

The torque constant is equal to the voltage constant.

DC Machine

$$K_T = K_E$$

The armature circuit is connected between the A+ and A- ports of the DC Machine block. It is represented by a series R_a L_a branch in series with a Controlled Voltage Source and a Current Measurement block.

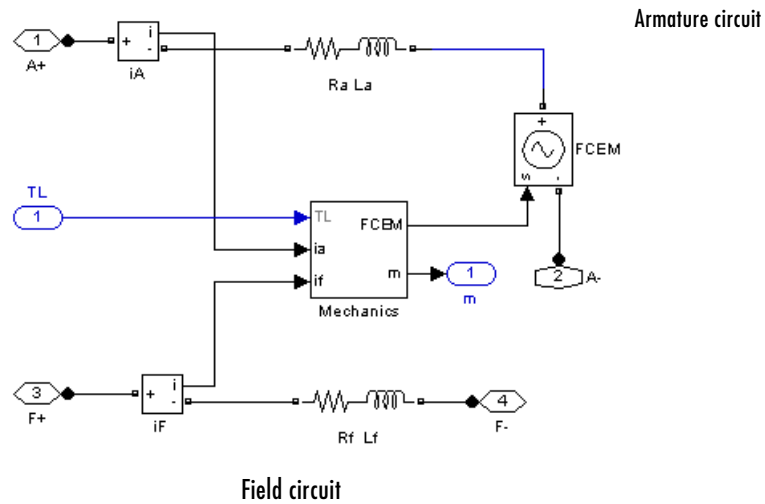

Mechanical part:

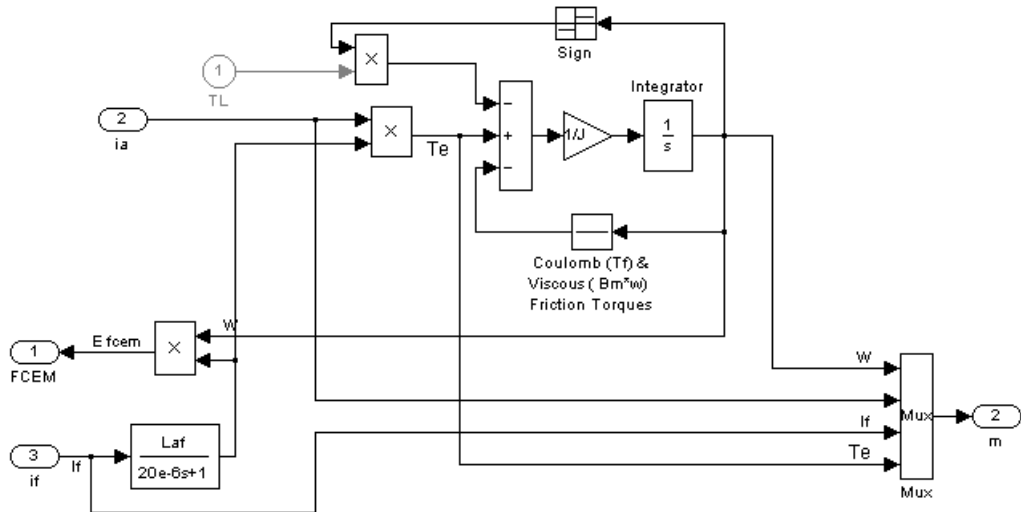

The field circuit is represented by an RL circuit. It is connected between the F+ and F- ports of the DC Machine block.

The mechanical part computes the speed of the DC machine from the net torque applied to the rotor. The speed is used to implement the CEMF voltage E of the armature circuit.

The mechanical part is represented by Simulink blocks that implement the equation

$$J \frac{d\omega}{dt} = T_e - \text{sgn}(\omega) T_L - B_m \omega - T_f$$

where J = inertia, B_m = viscous friction coefficient, and T_f = Coulomb friction torque.

DC Machine

Dialog Box and Parameters

Block Parameters: DC Machine

DC machine (mask)

This block implements a separately excited DC machine. Access is provided to the field connections so that the machine can be used as a shunt-connected or a series-connected DC machine.

Parameters

Preset model: No

Mechanical input: Torque TL

Show detailed parameters

Armature resistance and inductance [Ra (ohms) La (H)]
[0.5 0.01]

Field resistance and inductance [Rf (ohms) Lf (H)]
[240 120]

Field-armature mutual inductance Laf (H) :
1.8

Total inertia J (kg.m²)
0.05

Viscous friction coefficient Bm (N.m.s)
0.02

Coulomb friction torque Tf (N.m)
0

Initial speed (rad/s) :
0

OK Cancel Help Apply

Preset Model

Provides a set of predetermined electrical and mechanical parameters for various DC machine ratings of power (HP), DC voltage (V), rated speed (rpm), and field voltage (V).

Select one of the preset models to load the corresponding electrical and mechanical parameters in the entries of the dialog box. Select No if you don't want to use a preset model.

Select **Show detailed parameters** to view and edit the detailed parameters associated with the preset model.

Mechanical input

Allows you to select either the torque applied to the shaft or the rotor speed as the Simulink signal applied to the block's input.

Select **Torque Tm** to specify a torque input, in N.m or in p.u., and change labeling of the block's input to Tm. The machine speed is determined by the machine Inertia J (or inertia constant H for the p.u. machine) and by the difference between the applied mechanical torque Tm and the internal electromagnetic torque Te. The sign convention for the mechanical torque is the following: when the speed is positive, a positive torque signal indicates motor mode and a negative signal indicates generator mode.

Select **Speed w** to specify a speed input, in rad/s or in p.u., and change labeling of the block's input to w. The machine speed is imposed and the mechanical part of the model (Inertia J) is ignored. Using the speed as the mechanical input allows modeling a mechanical coupling between two machines and interfacing with SimMechanics and SimDriveline.

The next figure indicates how to model a stiff shaft interconnection in a motor-generator. The speed output of machine 1 (motor) is connected to the speed input of machine 2 (generator), while machine 2 electromagnetic torque output Te is applied to the mechanical torque input Tm of machine 1. The Kw factor takes into account speed units of both machines (pu or rad/s) and gear box ratio. The KT factor takes into account torque units of both machines (pu or N.m) and machine ratings. Also, as the inertia J2 is ignored in machine 2, J2 referred to machine 1 speed must be added to machine 1 inertia J1.

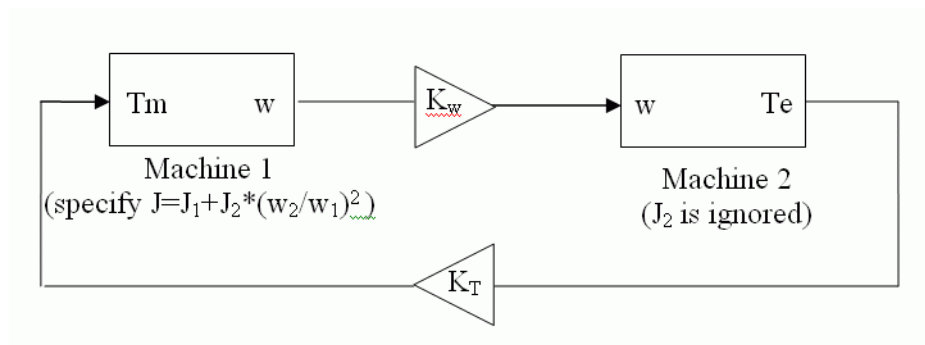

Show detailed parameters

If selected, the mask displays the detailed parameters of the DC Machine block. The detailed parameters can be modified no matter the preset model you selected in the **Preset Model** list.

DC Machine

Armature resistance and inductance [Ra La]

The armature resistance R_a , in ohms, and the armature inductance L_a , in henries.

Field resistance and inductance [Rf Lf]

The field resistance R_f , in ohms, and the field inductance L_f , in henries.

Field armature mutual inductance Laf

The field armature mutual inductance, in henries.

Total inertia J

The total inertia of the DC machine, in $\text{kg}\cdot\text{m}^2$.

Viscous friction coefficient Bm

The total friction coefficient of the DC machine, in $\text{N}\cdot\text{m}\cdot\text{s}$.

Coulomb friction torque Tf

The total Coulomb friction torque constant of the DC machine, in $\text{N}\cdot\text{m}$.

Initial speed

Specifies an initial speed for the DC machine, in rad/s , in order to start the simulation with a specific initial speed. To start the simulation in steady state, the initial value of the input torque signal T_L must be proportional to the initial speed.

Sample time

Specifies the sample time for the Discrete DC Machine block. This parameter is not available in the DC Machine block.

Inputs and Outputs

m

The Simulink output of the block is a vector containing four signals. You can demultiplex these signals by using the Bus Selector block provided in the Simulink library.

Signal	Definition	Units
1	Speed ω_m	rad/s
2	Armature current i_a	A

Signal	Definition	Units
3	Field current i_f	A
4	Electrical torque T_e	N.m

Example

The power_dcmotor demo illustrates the starting of a 5 HP 240 V DC machine with a three-step resistance starter.

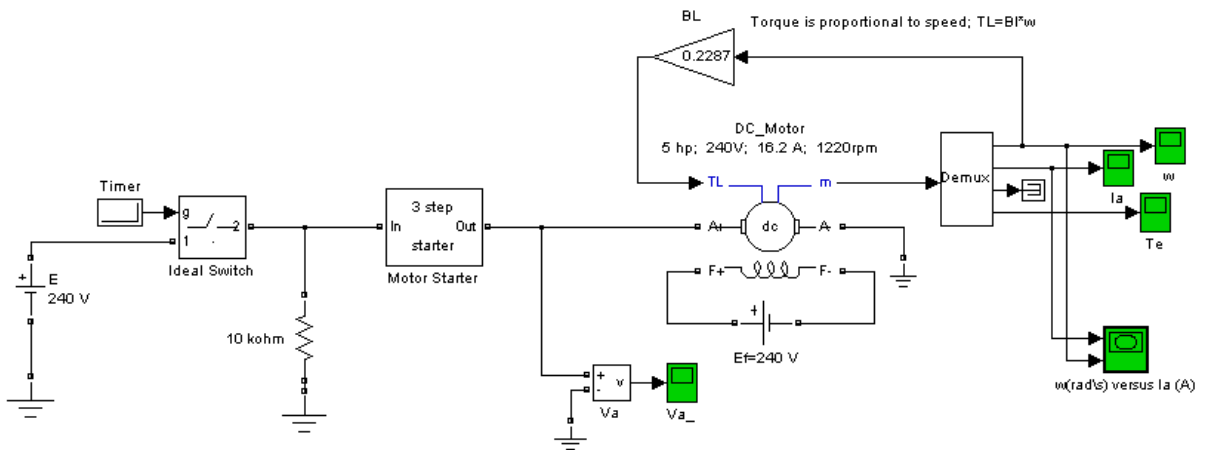

The Motor Starter subsystem is

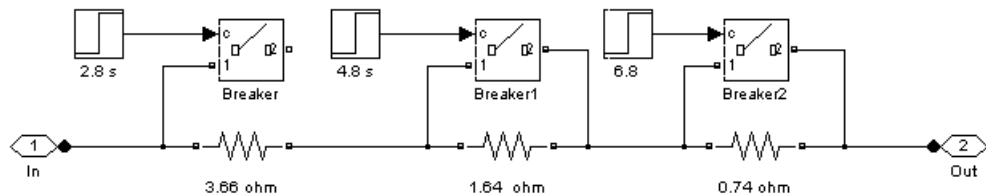

DC Machine

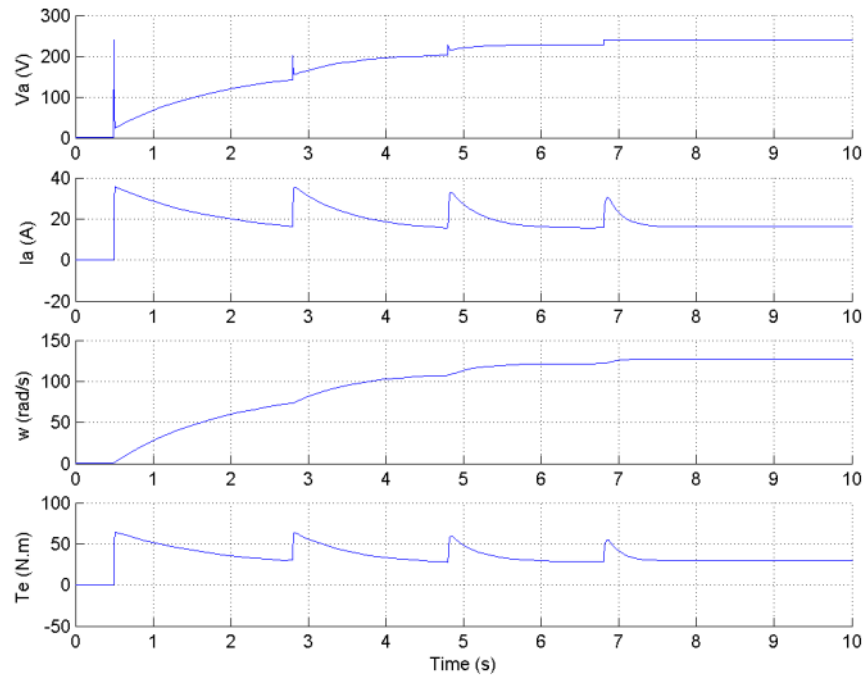

References

Analysis of Electric Machinery, Krause et al., pp. 89-92.

See Also

Asynchronous Machine, Synchronous Machine

Purpose Implement a DC voltage source

Library Electrical Sources

Description The DC Voltage Source block implements an ideal DC voltage source. The positive terminal is represented by a plus sign on one port. You can modify the voltage at any time during the simulation.



Dialog Box and Parameters

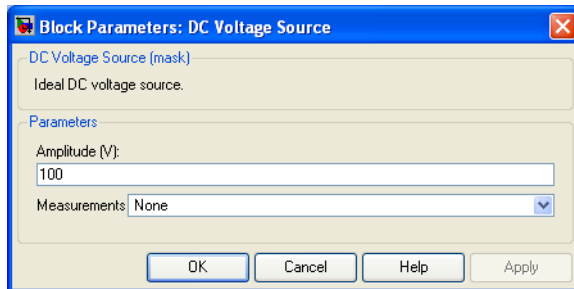

Amplitude

The amplitude of the source, in volts (V).

Measurements

Select `Voltage` to measure the voltage across the terminals of the DC Voltage Source block.

Place a Multimeter block in your model to display the selected measurements during the simulation. In the **Available Measurements** list box of the Multimeter block, the measurement is identified by a label followed by the block name:

Measurement	Label
Voltage	Usrc:

Example

The `power_dc voltage` demo illustrates the simulation of the transient response of a first-order RC circuit.

DC Voltage Source

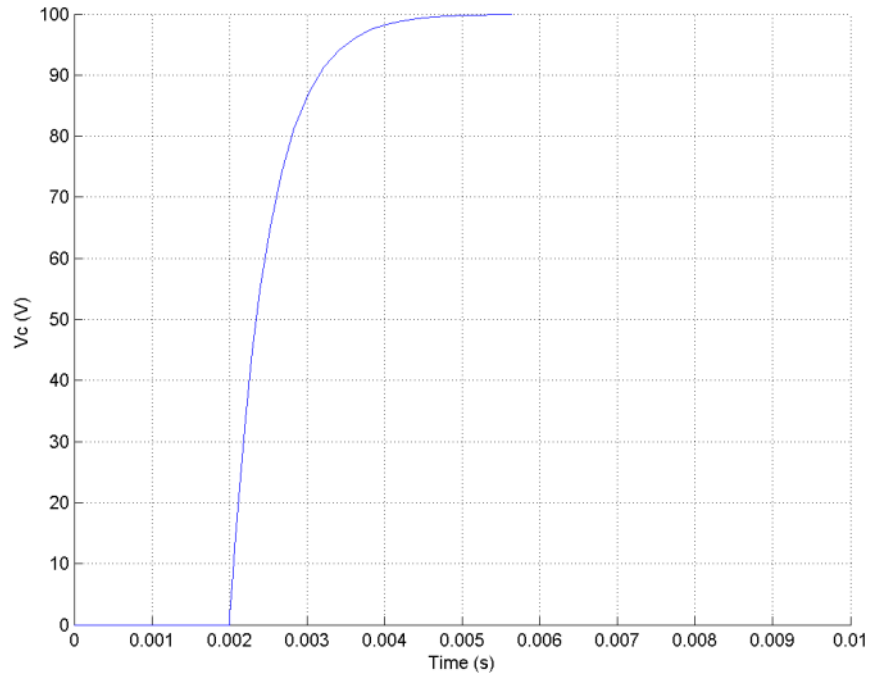
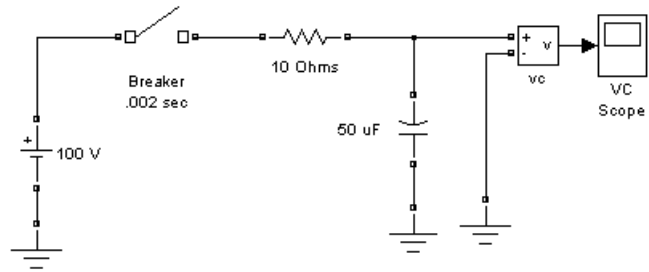

See Also

AC Voltage Source, Controlled Voltage Source

Purpose Implement a diode model

Library Power Electronics

Description

The diode is a semiconductor device that is controlled by its own voltage V_{ak} and current I_{ak} . When a diode is forward biased ($V_{ak} > 0$), it starts to conduct with a small forward voltage V_f across it. It turns off when the current flow into the device becomes 0. When the diode is reverse biased ($V_{ak} < 0$), it stays in the off state.

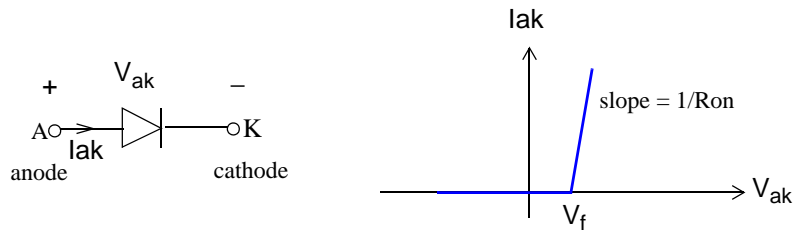
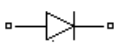
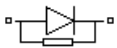
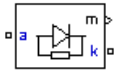

The Diode block is simulated by a resistor, an inductor, and a DC voltage source connected in series with a switch. The switch operation is controlled by the voltage V_{ak} and the current I_{ak} .

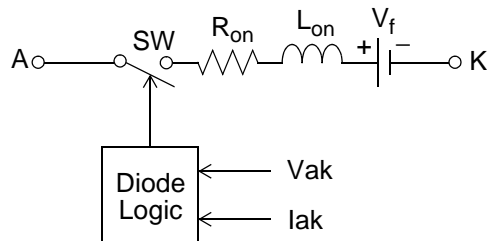

The Diode block also contains a series R_s - C_s snubber circuit that can be connected in parallel with the diode device (between nodes A and K).

Diode

Dialog Box and Parameters

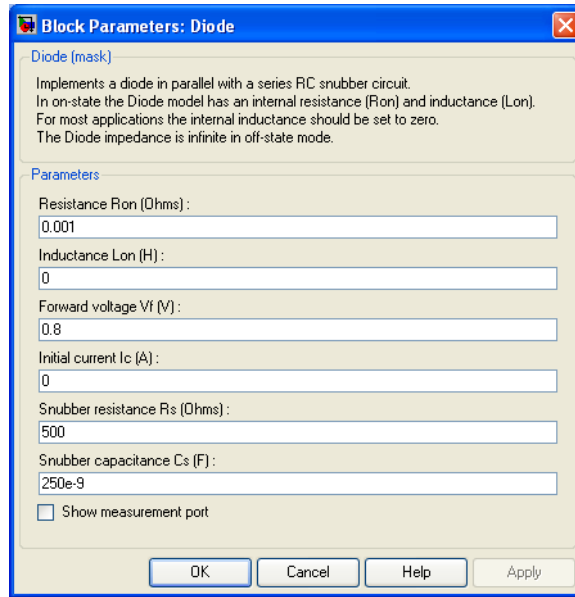

Resistance R_{on}

The diode internal resistance R_{on} , in ohms (Ω). The **Resistance R_{on}** parameter cannot be set to 0 when the **Inductance L_{on}** parameter is set to 0.

Inductance L_{on}

The diode internal inductance L_{on} , in henries (H). The **Inductance L_{on}** parameter cannot be set to 0 when the **Resistance R_{on}** parameter is set to 0.

Forward voltage V_f

The forward voltage of the diode device, in volts (V).

Initial current I_c

Specifies an initial current flowing in the diode device. It is usually set to 0 in order to start the simulation with the diode device blocked. If the **Initial Current I_c** parameter is set to a value greater than 0, the steady-state calculation of SimPowerSystems considers the initial status of the diode as closed.

Initializing all states of a power electronic converter is a complex task. Therefore, this option is useful only with simple circuits.

Snubber resistance R_s

The snubber resistance, in ohms (Ω). Set the **Snubber resistance R_s** parameter to `inf` to eliminate the snubber from the model.

Snubber capacitance C_s

The snubber capacitance in farads (F). Set the **Snubber capacitance C_s** parameter to 0 to eliminate the snubber, or to `inf` to get a resistive snubber.

Show measurement port

If selected, adds a Simulink output to the block returning the diode current and voltage.

Inputs and Outputs

m

The Simulink output of the block is a vector containing two signals. You can demultiplex these signals by using the Bus Selector block provided in the Simulink library.

Signal	Definition	Units
1	Diode current	A
2	Diode voltage	V

Assumptions and Limitations

The Diode block implements a macro model of a diode device. It does not take into account either the geometry of the device or the complex physical processes underlying the state change [1]. The leakage current in the blocking state and the reverse-recovery (negative) current are not considered. In most circuits, the reverse current does not affect converter or other device characteristics.

Depending on the value of the inductance L_{on} , the diode is modeled either as a current source ($L_{on} > 0$) or as a variable topology circuit ($L_{on} = 0$). The Diode block cannot be connected in series with an inductor, a current source, or an open circuit, unless its snubber circuit is in use. See Chapter 3, “Improving Simulation Performance” for more details on this topic.

Diode

Use the powergui block to specify either continuous simulation or discretization of your electrical circuit containing diodes. When using a continuous model, the ode23t stiff solver with a relative tolerance of $1e-4$ is recommended for best accuracy and simulation speed.

The inductance L_{on} is forced to 0 if you choose to discretize your circuit.

Example

The power_diode demo illustrates a single pulse rectifier consisting of a Diode block, an RL load, and an AC Voltage source block.

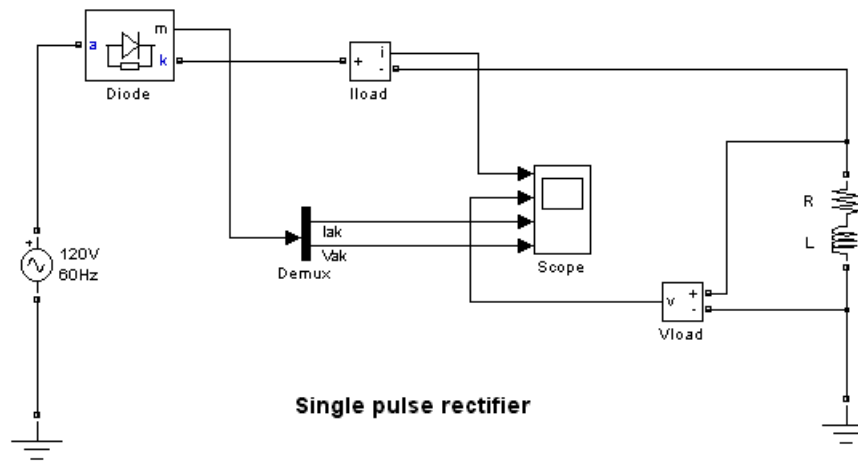

Simulation produces the following results.

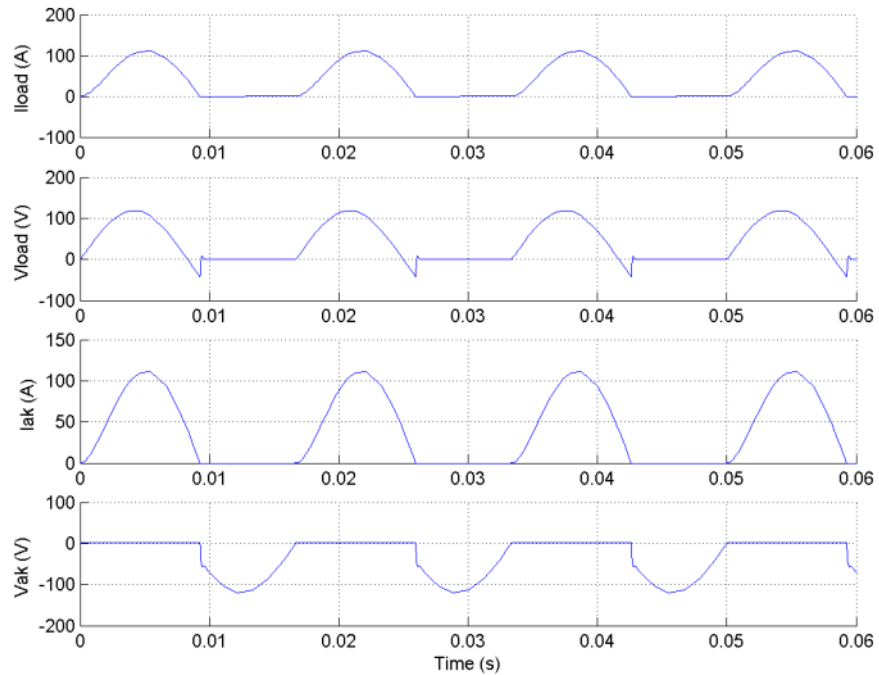

References

- [1] Rajagopalan, V., *Computer-Aided Analysis of Power Electronic Systems*, Marcel Dekker, Inc., New York, 1987.
- [2] Mohan, N., T.M. Undeland, and W.P. Robbins, *Power Electronics: Converters, Applications, and Design*, John Wiley & Sons, Inc., New York, 1995.

See Also

Thyristor, Universal Bridge

Discrete System

Purpose Discretize the state-space model of a circuit

Library powerlib

Description **Note** This block is now obsolete. Use the Powergui block to replace this block.

See Also Powergui

Distributed Parameter Line

Purpose

Implement an N-phase distributed parameter transmission line model with lumped losses

Library

Elements

Description

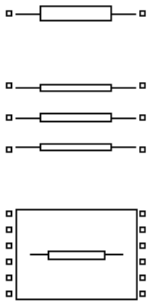

The Distributed Parameter Line block implements an N-phase distributed parameter line model with lumped losses. The model is based on the Bergeron's traveling wave method used by the Electromagnetic Transient Program (EMTP) [1]. In this model, the lossless distributed LC line is characterized by two values (for a single-phase line): the surge impedance $Z_c = \sqrt{L/C}$ and the phase velocity $v = 1/\sqrt{LC}$.

The model uses the fact that the quantity $e+Zi$ (where e is line voltage and i is line current) entering one end of the line must arrive unchanged at the other end after a transport delay of $\tau = d/v$, where d is the line length. By lumping $R/4$ at both ends of the line and $R/2$ in the middle and using the current injection method of SimPowerSystems, the following two-port model is derived.

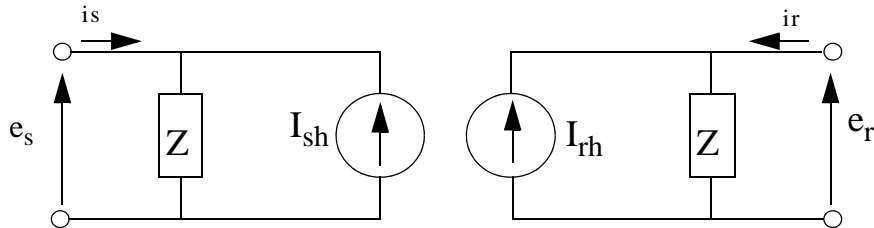

$$\text{where } Z = Z_C + \frac{R}{4} \text{ , } h = \frac{Z_C - \frac{R}{4}}{Z_C + \frac{R}{4}} \text{ , } Z_C = \sqrt{\frac{L}{C}} \text{ , and } \tau = d\sqrt{LC} \text{ .}$$

Distributed Parameter Line

For multiphase line models, modal transformation is used to convert line quantities from phase values (line currents and voltages) into modal values independent of each other. The previous calculations are made in the modal domain before being converted back to phase values.

In comparison to the PI section line model, the distributed line represents wave propagation phenomena and line end reflections with much better accuracy. See the comparison between the two models in the Example section.

Dialog Box and Parameters

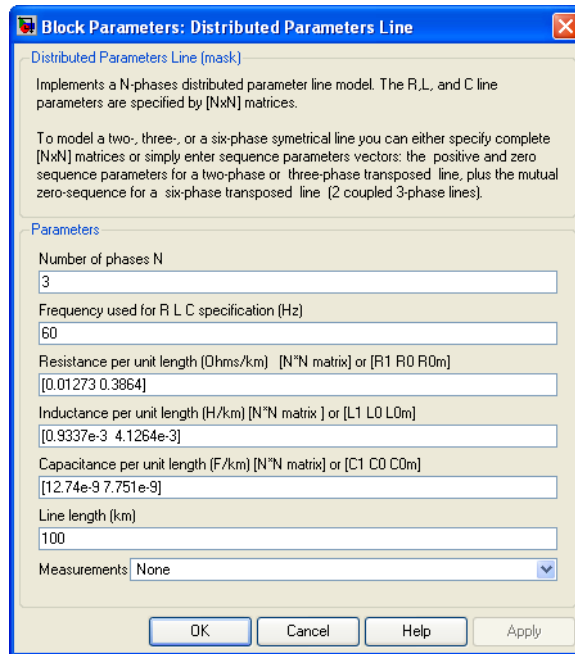

Number of phases N

Specifies the number of phases, N, of the model. The block icon dynamically changes according to the number of phases that you specify. When you apply the parameters or close the dialog box, the number of inputs and outputs is updated.

Frequency used for RLC specifications

Specifies the frequency used to compute the resistance R , inductance L , and capacitance C matrices of the line model.

Resistance per unit length

The resistance R per unit length, as an N-by-N matrix in ohms/km (Ω/km).

For a symmetrical line, you can either specify the N-by-N matrix or the sequence parameters. For a two-phase or three-phase continuously transposed line, you can enter the positive and zero-sequence resistances $[R1 R0]$. For a symmetrical six-phase line you can enter the sequence parameters plus the zero-sequence mutual resistance $[R1 R0 R0m]$.

For asymmetrical lines, you must specify the complete N-by-N resistance matrix.

Inductance per unit length

The inductance L per unit length, as an N-by-N matrix in henries/km (H/km).

For a symmetrical line, you can either specify the N-by-N matrix or the sequence parameters. For a two-phase or three-phase continuously transposed line, you can enter the positive and zero-sequence inductances $[L1 L0]$. For a symmetrical six-phase line, you can enter the sequence parameters plus the zero-sequence mutual inductance $[L1 L0 L0m]$.

For asymmetrical lines, you must specify the complete N-by-N inductance matrix.

Capacitance per unit length

The capacitance C per unit length, as an N-by-N matrix in farads/km (F/km).

For a symmetrical line, you can either specify the N-by-N matrix or the sequence parameters. For a two-phase or three-phase continuously transposed line, you can enter the positive and zero-sequence capacitances $[C1 C0]$. For a symmetrical six-phase line you can enter the sequence parameters plus the zero-sequence mutual capacitance $[C1 C0 C0m]$.

For asymmetrical lines, you must specify the complete N-by-N capacitance matrix.

Distributed Parameter Line

Note The Powergui block provide you a graphical tool for the calculation of the resistance, inductance, and capacitance per unit length based on the line geometry and the conductor characteristics.

Line length

The line length, in km.

Measurements

Select Phase-to-ground voltages to measure the sending end and receiving end voltages for each phase of the line model.

Place a Multimeter block in your model to display the selected measurements during the simulation.

In the **Available Measurements** list box of the Multimeter block, the measurement is identified by a label followed by the block name:

Measurement	Label
Phase-to-ground voltages, sending end	Us_ph1_gnd: , Us_ph2_gnd: , Us_ph3_gnd: , etc.
Phase-to-ground voltages, receiving end	Ur_ph1_gnd: , Ur_ph2_gnd: , Ur_ph3_gnd: , etc.

Limitations

This model does not represent accurately the frequency dependence of RLC parameters of real power lines. Indeed, because of the skin effects in the conductors and ground, the R and L matrices exhibit strong frequency dependence, causing an attenuation of the high frequencies.

Distributed Parameter Line

Example

The power_monophaseline demo illustrates a 200 km line connected on a 1 kV, 60 Hz infinite source. The line is de-energized and then reenergized after 2 cycles. The simulation is performed simultaneously with the Distributed Parameter Line block and with the PI Section Line block.

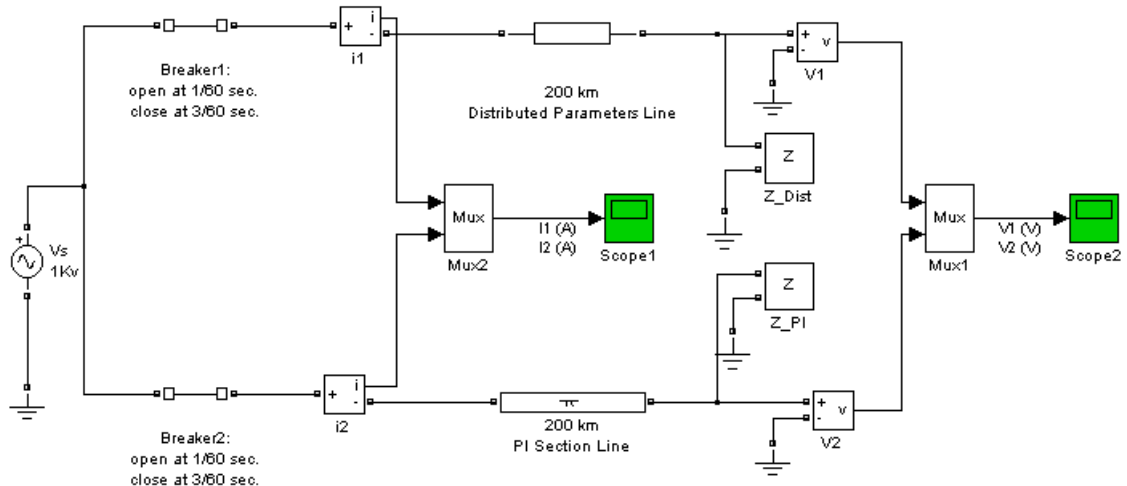

Distributed Parameter Line

The receiving end voltage obtained with the Distributed Parameter Line block is compared with the one obtained with the PI Section Line block (two sections).

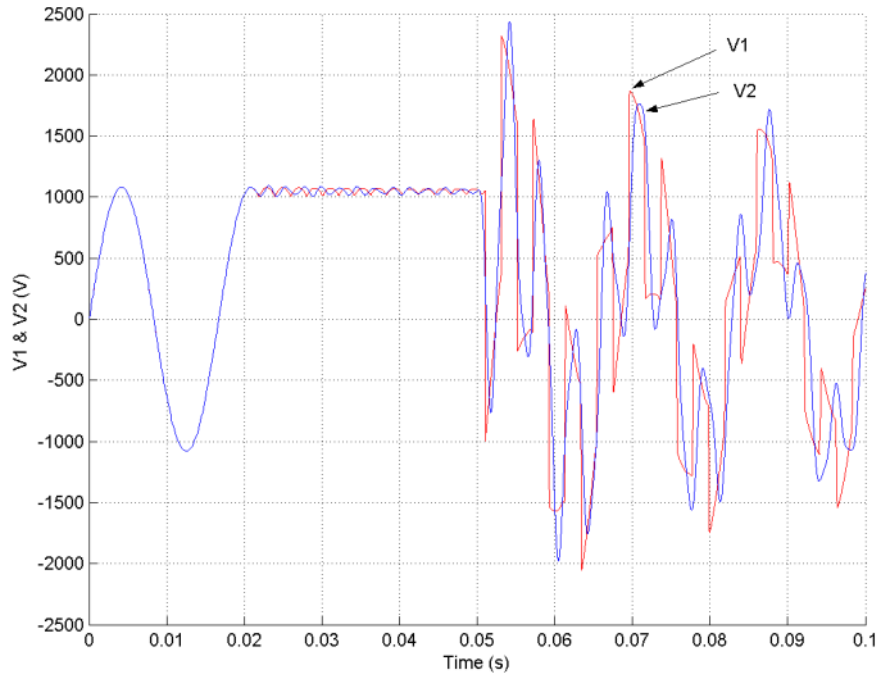

Distributed Parameter Line

Open the Powergui. Click the **Impedance vs Frequency Measurement** button. A new window appears, listing the two Impedance Measurement blocks connected to your circuit. Set the parameters of **Impedance vs Frequency Measurement** to compute impedance in the [0,2000] Hz frequency range, select the two measurements in the list, then click the **Update** button.

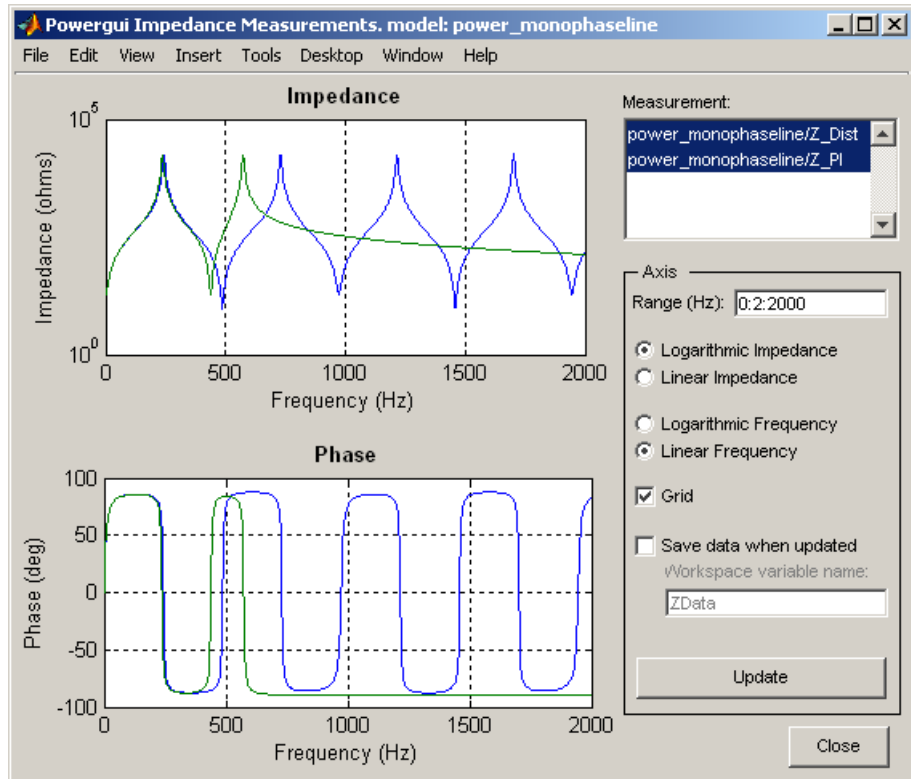

The distributed parameter line shows a succession of poles and zeros equally spaced, every 486 Hz. The first pole occurs at 243 Hz, corresponding to frequency $f = 1/(4 * T)$, where

$$T = \text{traveling time} = l\sqrt{LC} = 1.028 \text{ ms}$$

The PI section line only shows two poles because it consists of two PI sections. Impedance comparison shows that a two-section PI line gives a good approximation of the distributed line for the 0 to 350 Hz frequency range.

Distributed Parameter Line

References

[1] Dommel, H., "Digital Computer Solution of Electromagnetic Transients in Single and Multiple Networks," *IEEE Transactions on Power Apparatus and Systems*, Vol. PAS-88, No. 4, April, 1969.

See Also

PI Section Line

Purpose Perform a Park transformation from the dq0 reference frame to the abc reference frame

Library Extras/Measurements

A discrete version of this block is available in the Extras/Discrete Measurements library.

Description

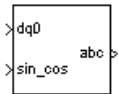

The dq0_to_abc Transformation block performs the reverse of the so-called Park transformation, which is commonly used in three-phase electric machine models. It transforms three quantities (direct axis, quadratic axis, and zero-sequence components) expressed in a two-axis reference frame back to phase quantities. The following transformation is used:

$$V_a = V_d \sin(\omega t) + V_q \cos(\omega t) + V_0$$

$$V_b = V_d \sin(\omega t - 2\pi/3) + V_q \cos(\omega t - 2\pi/3) + V_0$$

$$V_c = V_d \sin(\omega t + 2\pi/3) + V_q \cos(\omega t + 2\pi/3) + V_0$$

where

ω = rotation speed (rad/s) of the rotating frame

The transformation is the same for the case of a three-phase current; you simply replace the V_a , V_b , V_c , V_d , V_q , and V_0 variables with the I_a , I_b , I_c , I_d , I_q , and I_0 variables.

The dq0_to_abc Transformation block is used in the model of the Synchronous Machine block where the stator quantities are referred to the rotor. The Park transformation then eliminates time-varying inductances by referring the stator and rotor quantities to a fixed or rotating reference frame. The I_d and I_q currents represent the two DC currents flowing in the two equivalent rotor windings (d winding on the same axis as the field winding, and q winding in quadratic) producing the same flux as the stator I_a , I_b , and I_c currents.

dq0_to_abc Transformation

Dialog Box and Parameters

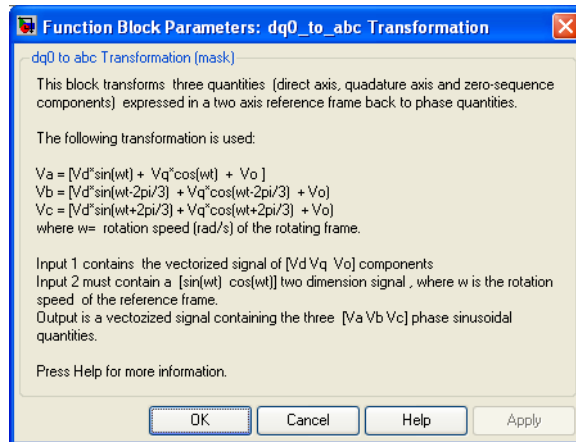

Inputs and Outputs

dq0

Connect to the first input a vectorized signal containing the sequence components [d q 0] to be converted.

sin_cos

Connect to the second input a vectorized signal containing the [sin(ωt) cos(ωt)] values, where ω is the rotation speed of the reference frame.

abc

The output is a vectorized signal containing the three-phase sinusoidal quantities [phase A phase B phase C].

Example

See the demo of the abc_to_dq0 Transformation block for an example using the dq0_to_abc Transformation block.

See Also

abc_to_dq0 Transformation

DTC Induction Motor Drive

Purpose

Implement a direct torque and flux control (DTC) induction motor drive model

Library

Electric Drives/AC drives

Description

The high-level schematic shown below is built from six main blocks. The induction motor, the three-phase inverter, and the three-phase diode rectifier models are provided with the SimPowerSystems library. More details on these three blocks are available in the reference sections of each block. The speed controller, the braking chopper, and the DTC controller models are specific to the drive library.

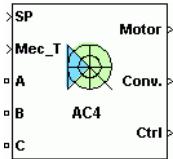

Note In SimPowerSystems, the DTC Induction Motor Drive block is commonly called the AC4 motor drive.

High-Level Schematic

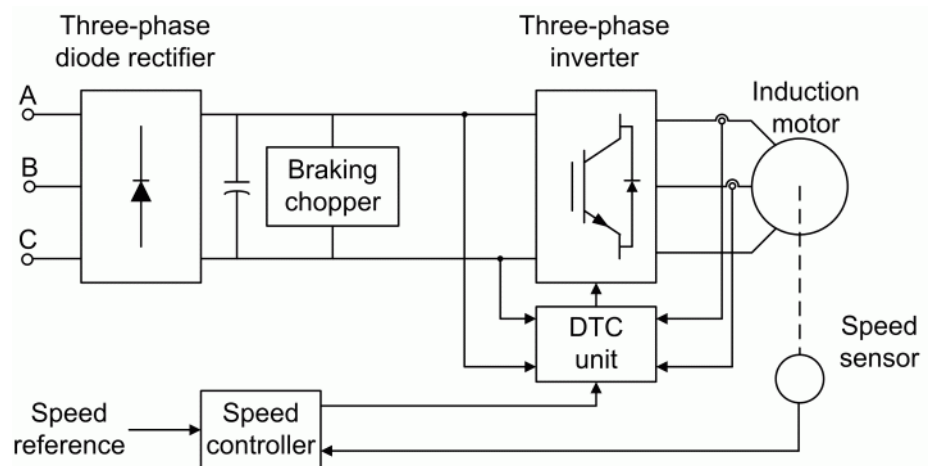

DTC Induction Motor Drive

Simulink Schematic

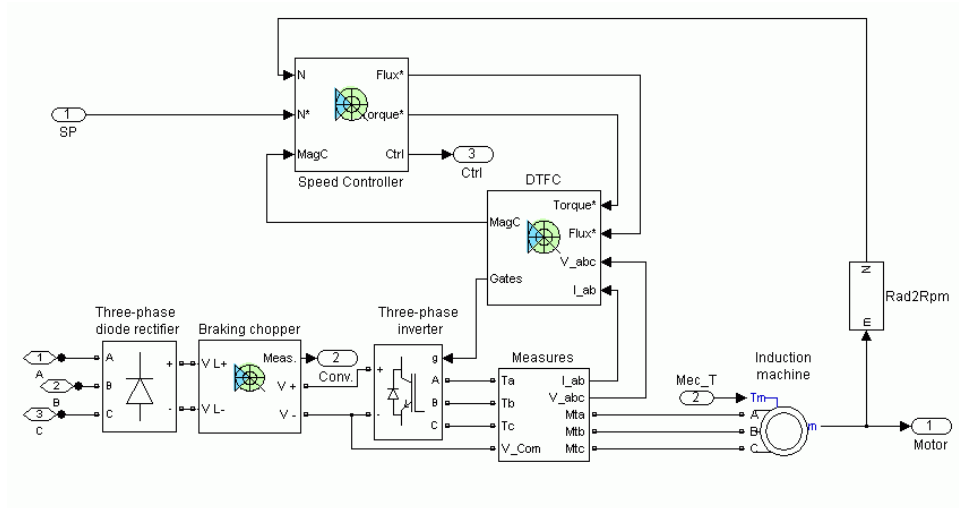

Speed Controller

The speed controller is based on a PI regulator, shown below. The output of this regulator is a torque set point applied to the DTC controller block.

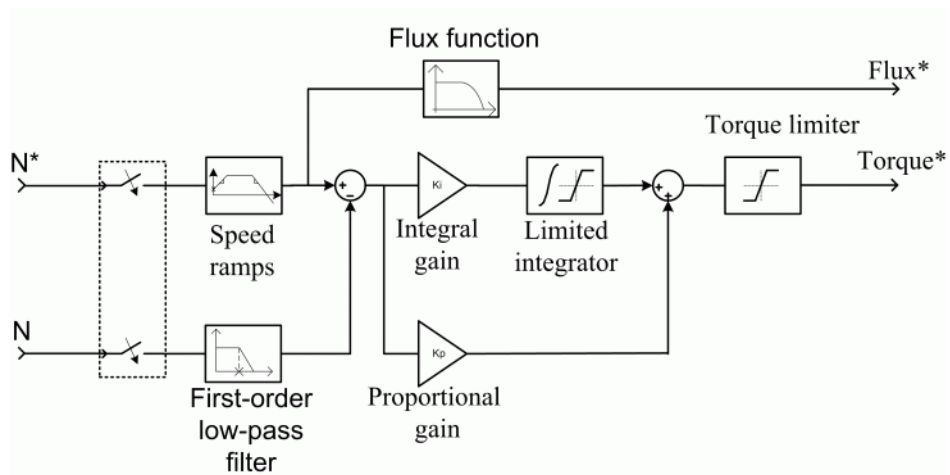

DTC Controller The Direct Torque and Flux Control (DTC) controller contains five main blocks, shown below. These blocks are described below.

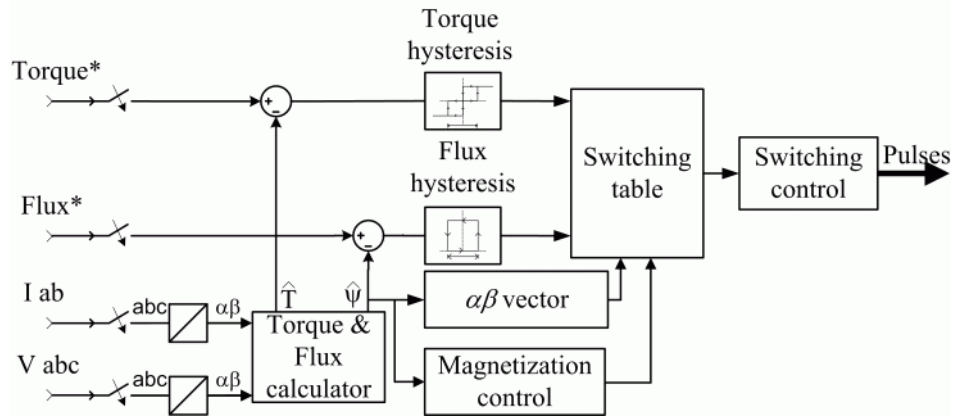

The *Torque & Flux calculator* block is used to estimate the motor flux $\alpha\beta$ components and the electromagnetic torque. This calculator is based on motor equation synthesis.

The *$\alpha\beta$ vector* block is used to find the sector of the $\alpha\beta$ plane in which the flux vector lies. The $\alpha\beta$ plane is divided into six different sectors spaced by 60 degrees.

The *Flux & Torque Hysteresis* blocks contain a two-level hysteresis comparator for flux control and a three-level hysteresis comparator for the torque control. The description of the hysteresis comparators is available below.

The *Switching table* block contains two lookup tables that select a specific voltage vector in accordance with the output of the *Flux & Torque Hysteresis* comparators. This block also produces the initial flux in the machine.

The *Switching control* block is used to limit the inverter commutation frequency to a maximum value specified by the user.

DTC Induction Motor Drive

Braking Chopper

The braking chopper block contains the DC bus capacitor and the dynamic braking chopper, which is used to absorb the energy produced by a motor deceleration.

Remarks

The model is discrete. Good simulation results have been obtained with a 2 μ s time step. In order to simulate a digital controller device, the control system has two different sampling times:

- The speed controller sampling time
- The D.T.C. controller sampling time

The speed controller sampling time has to be a multiple of the D.T.C. sampling time. The latter sampling time has to be a multiple of the simulation time step.

Dialog Box

Asynchronous Machine Tab

The screenshot shows the 'DTC Induction Motor Drive' dialog box with the 'Asynchronous Machine' tab selected. The dialog contains several sections for parameter configuration:

- Reference frame:** Stationary (dropdown menu)
- Nominal values:**
 - Power (VA): 2238
 - Voltage (Vrms): 220
 - Frequency (Hz): 60
- Equivalent circuit values:**
 - Resistance (ohm): Stator: 0.435, Rotor: 0.816
 - Leakage inductance (H): Stator: 2e-3, Rotor: 2e-3
 - Mutual inductance (H): 69.31e-3
- Initial currents:**
 - Phase A: Magnitude (A): 0, Phase (deg): 0
 - Phase B: Magnitude (A): 0, Phase (deg): 0
 - Phase C: Magnitude (A): 0, Phase (deg): 0
- Mechanical parameters:**
 - Rotor values:
 - Inertia (kg*m²): 0.089
 - Friction (N-m-s): 0.005
 - Pole pairs: 2
 - Initial values:
 - Slip: 1
 - Angle (deg): 0
- Parameters file options:** Load, Save buttons
- Buttons:** OK, Cancel, Help, Apply

The asynchronous machine tab displays the parameters of the asynchronous machine block of the powerlib library. Refer to the Asynchronous Machine for more information on the Asynchronous Machine tab parameters.

DTC Induction Motor Drive

Converters and DC Bus Tab

The screenshot shows the 'DTC Induction Motor Drive' software window. The 'Converters and DC bus' tab is selected. The interface is divided into several sections:

- Rectifier:** Includes 'Snubbers' (Resistance: 10e3, Capacitance: 2e-9) and 'Diodes' (On-state resistance: 1e-3, Forward voltage: 1.3).
- DC Bus:** Includes 'Capacitance (F): 1500e-6' and 'Braking chopper' (Resistance: 8, Chopper frequency: 4000, Activation voltage: 340, Shutdown voltage: 320).
- Inverter:** Includes 'Switches' (Device type: IGBT / Diodes, On-state resistance: 1e-3, Forward voltages: Main device: 1.4, Diode: 1.4, Turn-off characteristics: Fall time: 1e-6, Tail time: 2e-6) and 'Snubbers' (Resistance: 10e3, Capacitance: inf).
- Parameters file options:** Includes 'Load' and 'Save' buttons.

At the bottom of the window are 'OK', 'Cancel', 'Help', and 'Apply' buttons.

Rectifier Section

The rectifier section of the Converters and DC Bus tab displays the parameters of the rectifier block of the powerlib library. Refer to the Universal Bridge for more information on the rectifier parameters.

Inverter Section

The inverter section of the Converters and DC Bus tab displays the parameters of the Inverter block of the powerlib library. Refer to the Universal Bridge for more information on the inverter parameters.

DC-Bus Capacitance

The DC bus capacitance (F).

Braking Chopper section: Resistance

The braking chopper resistance used to avoid bus over-voltage during motor deceleration or when the load torque tends to accelerate the motor (Ω).

Braking Chopper section: Frequency

The braking chopper frequency (Hz).

Braking Chopper section: Activation Voltage

The dynamic braking is activated when the bus voltage reaches the upper limit of the hysteresis band. The following figure illustrates the braking chopper hysteresis logic.

Braking Chopper section: Shutdown Voltage

The dynamic braking is shut down when the bus voltage reaches the lower limit of the hysteresis band. The Chopper hysteresis logic is shown below:

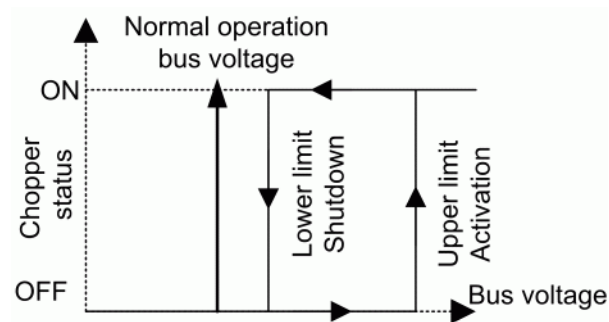

DTC Induction Motor Drive

Controller Tab

DTC Induction Motor Drive

The AC motor parameters are specified in the AC Machine tab. The braking chopper, the diode rectifier and the inverter switches parameters are specified in the Converter and DC bus tab. DTC and speed controller parameters are specified in the Controller Tab.

Asynchronous Machine Converter and DC bus Controller

Regulation type: Speed regulation Schematic

Speed controller

Speed ramps (rpm/s)

Acceleration: 900 Deceleration: -900 Speed cutoff frequency (Hz): 100 Speed controller sampling time (s): 7*20e-6

PI regulator

Proportional gain: 30 Integral gain: 200 Torque output limits (N-m)

Minimum: -1200 Maximum: 1200

DTC controller

Hysteresis bandwidth

Torque (N-m): 10 Flux (Wb): 0.02 Initial machine flux (Wb): 0.8 Maximum switching frequency (Hz): 20000 DTC sampling time (s): 20e-6

Parameters file options

Load Save

OK Cancel Help Apply

Regulation type

This parameter allows you to choose between speed and torque regulation.

Schematic

When you press this button, a diagram illustrating the speed and current controllers schematics appears.

Speed Controller section: Acceleration

The maximum change of speed allowed during motor acceleration. An excessively large positive value can cause DC bus under-voltage (rpm/s).

Speed Controller section: Deceleration

The maximum change of speed allowed during motor deceleration. An excessively large negative value can cause DC bus over-voltage (rpm/s).

Speed controller: Speed cutoff frequency

The speed measurement first-order low-pass filter cutoff frequency (Hz).

Speed controller: Speed controller sampling time

The speed controller sampling time (s). The sampling time must be a multiple of the simulation time step.

Speed controller: Proportional gain

The speed controller proportional gain.

Speed controller: Integral gain

The speed controller integral gain.

Speed controller: Torque Output Limits — Minimum

The maximum negative demanded torque applied to the motor by the DTC controller (N.m).

Speed Controller: Torque Output Limits — Maximum

The maximum positive demanded torque applied to the motor by the DTC controller (N.m).

DTC controller: Maximum switching frequency

The maximum inverter switching frequency (Hz).

DTC controller: Initial machine flux

The desired initial stator flux established before the DTC drive module begins to produce an electromagnetic torque. This flux is produced by applying a constant voltage vector at the motor terminals (Wb).

DTC controller: DTC sampling time

The DTC controller sampling time (s). The sampling time must be a multiple of the simulation time step.

DTC controller: Hysteresis bandwidth — Torque

The torque hysteresis bandwidth. This value is the total bandwidth distributed symmetrically around the torque set point (N.m). The following figure illustrates a case where the torque set point is T_e^* and the torque hysteresis bandwidth is set to dT_e .

DTC Induction Motor Drive

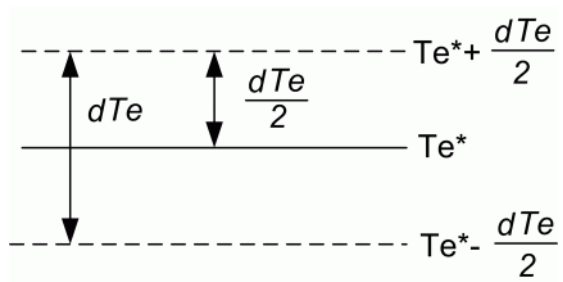

DTC controller: Hysteresis bandwidth — Flux

The stator flux hysteresis bandwidth. This value is the total bandwidth distributed symmetrically around the flux set point (Ψ_b). The following figure illustrates a case where the flux set point is ψ^* and the torque hysteresis bandwidth is set to $d\psi$.

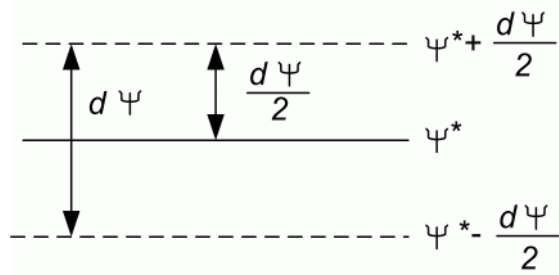

Block Inputs and Outputs

SP

The speed or torque set point. Note that the speed set point can be a step function, but the speed change rate will follow the acceleration / deceleration ramps. If the load torque and the speed have opposite signs, the accelerating torque will be the sum of the electromagnetic and load torques.

Mec_T

The mechanical load torque input.

A, B, C

The three phase terminals of the motor drive.

Motor

The motor measurement vector. This vector allows you to observe the motor's variables using the Bus Selector block.

Conv

The three-phase converters measurement vector. This vector contains:

- The DC bus voltage
- The rectifier output current
- The inverter input current

Note that all current and voltage values of the bridges can be visualized with the Multimeter block.

Ctrl

The controller measurement vector. This vector contains:

- The torque reference
- The speed error (difference between the speed reference ramp and actual speed)
- The speed reference ramp or torque reference

DTC Induction Motor Drive

Model Specifications

The library contains a 3 hp and a 200 hp drive parameter set. The specifications of these two drives are shown in the following table.

Drive Specifications

		3 HP Drive	200 HP Drive
Drive Input Voltage			
	Amplitude	220 V	460 V
	Frequency	60 Hz	60 Hz
Motor Nominal Values			
	Power	3 hp	200 hp
	Speed	1705 rpm	1785 rpm
	Voltage	220 V	460 V

Example

The ac4_example demo illustrates the simulation of an AC4 motor drive with standard load condition.

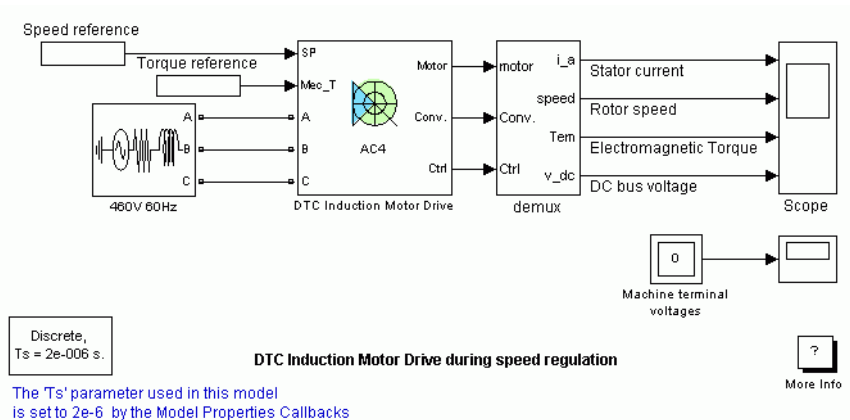

At time $t = 0$ s, the speed set point is 500 rpm. As shown in the following figure, the speed precisely follows the acceleration ramp. At $t = 0.5$ s, the nominal load torque is applied to the motor. At $t = 1$ s, the speed set point is changed to 0

rpm. The speed decreases to 0 rpm. At $t = 1.5$ s., the mechanical load passes from 792 N.m to -792 N.m.

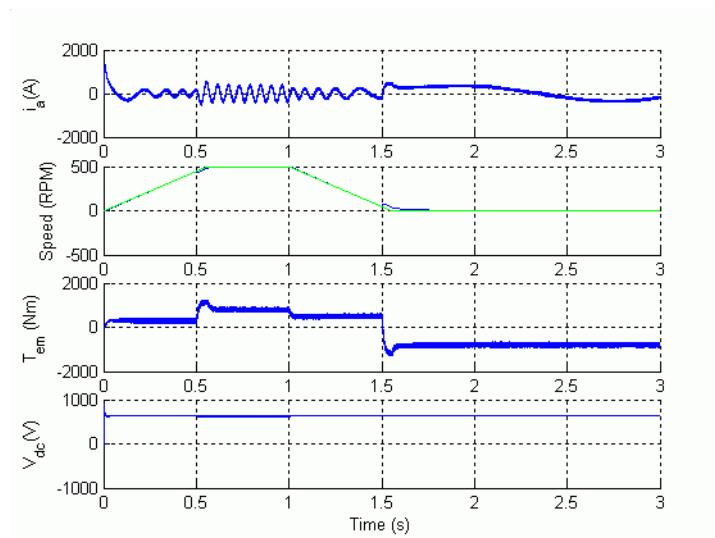

References

- [1] Bose, B. K., *Modern Power Electronics and AC Drives*, Prentice-Hall, N.J., 2002.
- [2] Grelet, G., and G. Clerc, *Actionneurs électriques*, Éditions Eyrolles, Paris, 1997.
- [3] Krause, P. C., *Analysis of Electric Machinery*, McGraw-Hill, 1986.

Excitation System

Purpose

Provide an excitation system for the synchronous machine and regulate its terminal voltage in generating mode

Library

Machines

Description

The Excitation System block is a Simulink system implementing a DC exciter described in [1], without the exciter's saturation function. The basic elements that form the Excitation System block are the voltage regulator and the exciter.

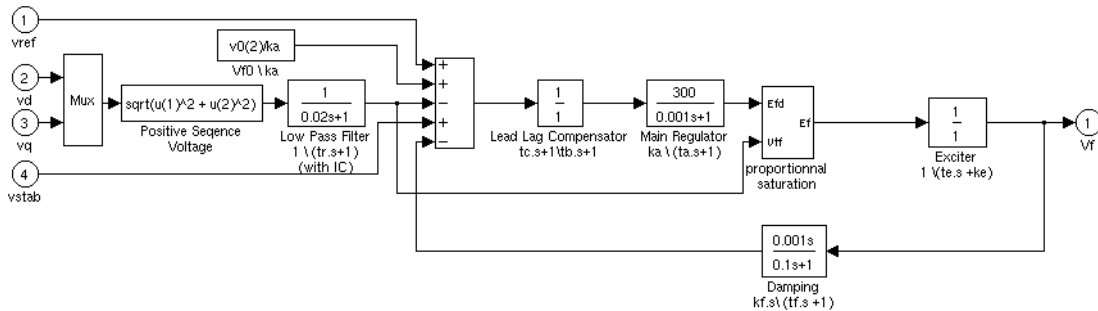

The exciter is represented by the following transfer function between the exciter voltage V_{fd} and the regulator's output ef :

$$\frac{V_{fd}}{ef} = \frac{1}{Ke + sTe}$$

Dialog Box and Parameters

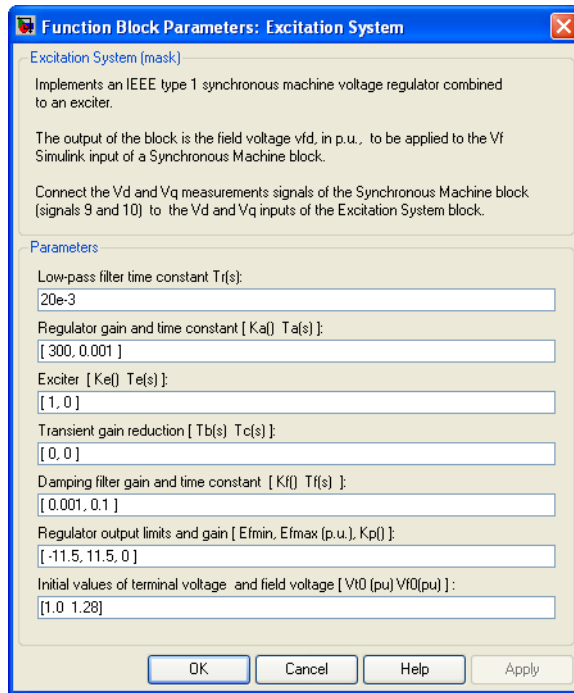

Low-pass filter time constant

The time constant T_r , in seconds (s), of the first-order system that represents the stator terminal voltage transducer.

Regulator gain and time constant

The gain K_a and time constant T_a , in seconds (s), of the first-order system representing the main regulator.

Exciter

The gain K_e and time constant T_e , in seconds (s), of the first-order system representing the exciter.

Transient gain reduction

The time constants T_b , in seconds (s), and T_c , in seconds (s), of the first-order system representing a lead-lag compensator.

Excitation System

Damping filter gain and time constant

The gain K_f and time constant T_f , in seconds (s), of the first-order system representing a derivative feedback.

Regulator output limits and gain

Limits E_{fmin} and E_{fmax} are imposed on the output of the voltage regulator. The upper limit can be constant and equal to E_{fmax} , or variable and equal to the rectified stator terminal voltage V_{tf} times a proportional gain K_p . If K_p is set to 0, the former applies. If K_p is set to a positive value, the latter applies.

Initial values of terminal voltage and field voltage

The initial values of terminal voltage V_{t0} (p.u.) and field voltage V_{f0} (p.u.). When set correctly, they allow you to start the simulation in steady state. Initial terminal voltage should normally be set to 1 p.u. Both V_{t0} and V_{f0} values are automatically updated by the load flow utility of the Powergui block.

Example

See the Hydraulic Turbine and Governor block.

Inputs and Outputs

v_{ref}

The desired value, in p.u., of the stator terminal voltage.

v_d

v_d component, in p.u., of the terminal voltage.

v_q

v_q component, in p.u., of the terminal voltage.

v_{stab}

Connect this input to a power system stabilizer to provide additional stabilization of power system oscillations.

V_f

The field voltage, in p.u., for the Synchronous Machine block.

References

[1] "Recommended Practice for Excitation System Models for Power System Stability Studies," *IEEE Standard 421.5-1992*, August, 1992.

See Also

Generic Power System Stabilizer, Hydraulic Turbine and Governor, Multiband Power System Stabilizer, Steam Turbine and Governor, Synchronous Machine

Field-Oriented Control Induction Motor Drive

Purpose

Implement a field-oriented control (FOC) induction motor drive model

Library

Electric Drives/AC drives

Description

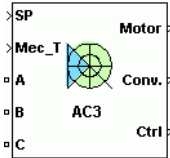

The high-level schematic shown below is built from six main blocks. The induction motor, the three-phase inverter, and the three-phase diode rectifier models are from blocks provided in the SimPowerSystems library. The speed controller, the braking chopper, and the FOC models are from blocks provided in the Electric Drives library. It is possible to use a simplified version of the drive containing an average-value model of the inverter and allowing faster simulation.

Note In SimPowerSystems, the Field-Oriented Control Induction Motor Drive block is commonly called the AC3 motor drive.

High-Level Schematic

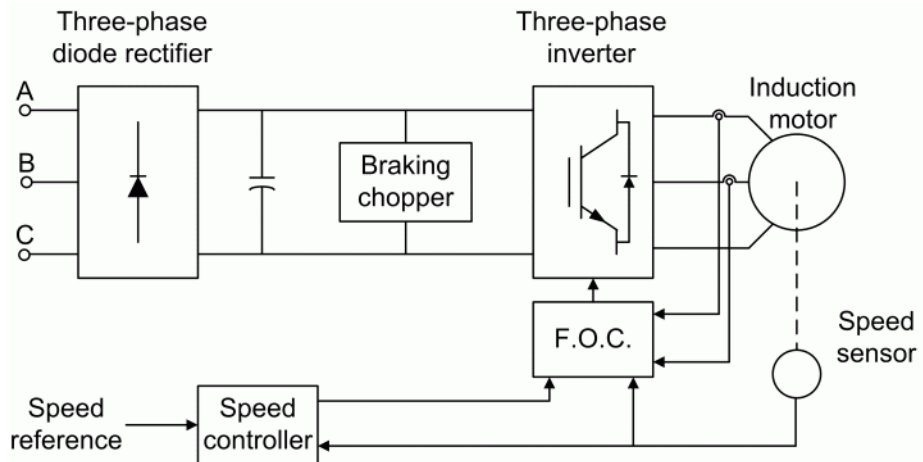

Field-Oriented Control Induction Motor Drive

Simulink Schematic

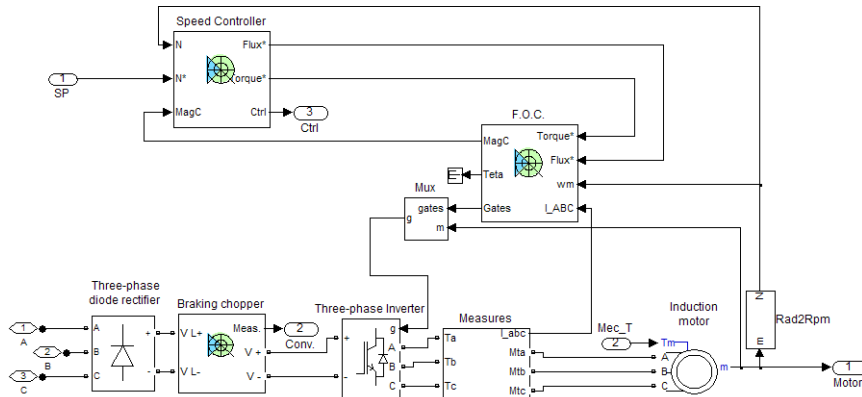

Speed Controller

The speed controller is based on a PI regulator, shown below. The outputs of this regulator are set points for the torque and the flux applied to the FOC block.

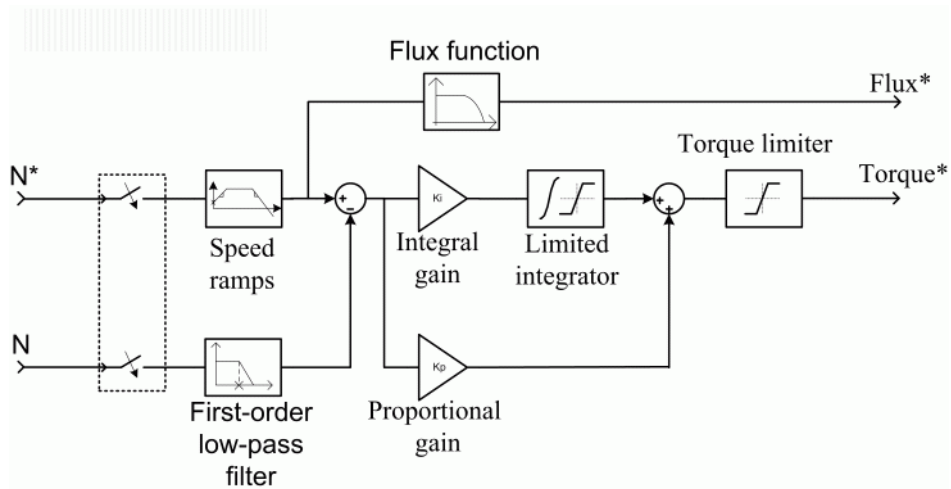

Field-Oriented Control Induction Motor Drive

Field Oriented Controller

The FOC block contains eleven main blocks. These blocks are described below in the Indirect Vector Control Simulink Schematic.

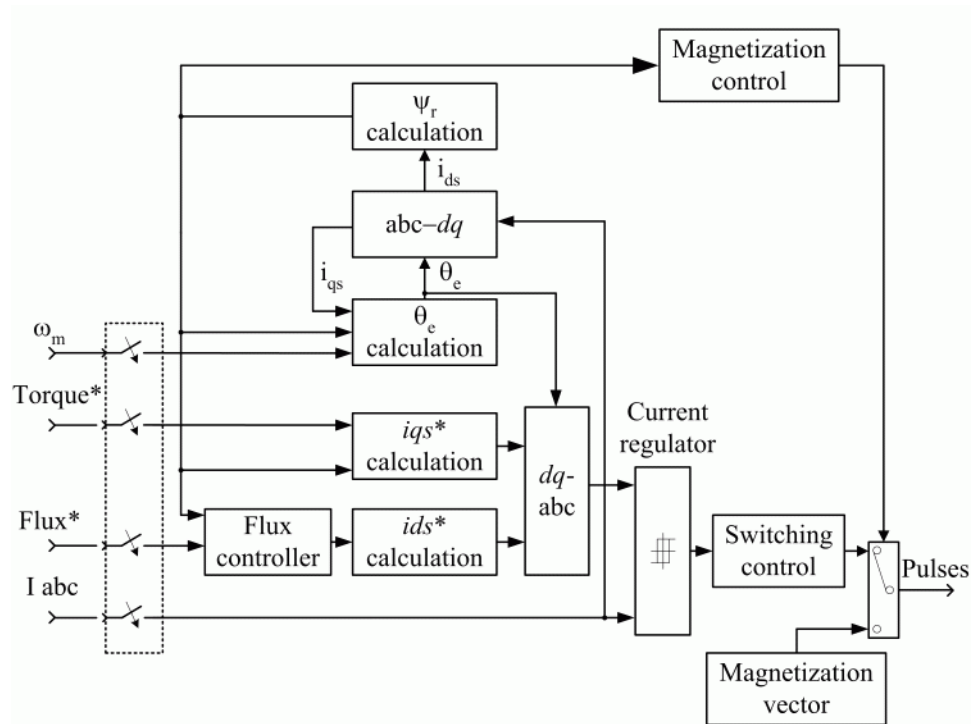

The ψ_r calculation block is used to estimate the motor's rotor flux. This calculation is based on motor equation synthesis.

The θ_e calculation block is used to find the phase angle of the rotor flux rotating field.

The abc - dq block performs the conversion of abc phase variables into dq components of the rotor flux rotating field reference frame.

The dq - abc block performs the conversion of the dq component of the rotor flux rotating field reference frame into abc phase variables.

Field-Oriented Control Induction Motor Drive

The *iqs*calculation* block uses the calculated rotor flux and the torque reference to compute the stator current quadrature component required to produce the electromagnetic torque on the motor's shaft.

The *ids*calculation* block uses the rotor flux reference to compute the stator current direct component required to produce the rotor flux in the machine.

The *current regulator* is a bang-bang current controller with adjustable hysteresis band width.

The *switching control* block is used to limit the inverter commutation frequency to a maximum value specified by the user.

The *flux controller* is used to control the flux dynamics and to reduce the steady-state flux error.

The *magnetization vector* unit contains the vector used to create the motor initial flux.

The *magnetization control* unit contains the logic used to switch between the magnetization and normal operation mode.

Braking Chopper

The braking chopper block contains the DC bus capacitor and the dynamic braking chopper, which is used to absorb the energy produced by a motor deceleration.

Average-Value Inverter

The average-value inverter is shown in the following figure.

Field-Oriented Control Induction Motor Drive

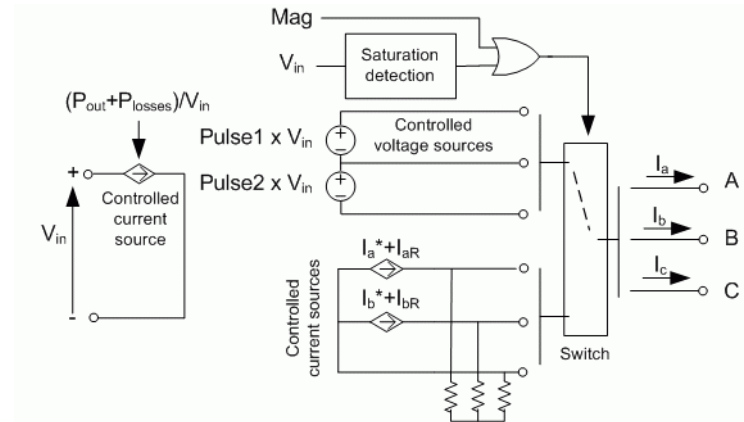

It is composed of one controlled current source on the DC side and of two controlled current sources and two controlled voltage sources on the AC side. The DC current source allows the representation of the average DC bus current behavior following the next equation:

$$I_{dc} = (P_{out} + P_{losses})/V_{in}$$

with P_{out} being the output power and P_{losses} the losses in the power electronics devices and V_{in} the DC bus voltage.

On the AC side, the current sources represent the average phase currents fed to the motor. The regulation being fast, the current values are set equal to the current references sent by the current regulator. A small current is injected to compensate the current drawn by the three-phase load (needed because of the inverter current sources in series with inductive motor).

During loss of current tracking due to insufficient inverter voltage, the currents are fed by two controlled voltage sources. These voltage sources represent the square wave mode and allow good representation of the phase currents during inverter saturation. Each voltage source outputs either V_{in} or 0, depending on the values of the pulses (1 or 0) sent by the current controller.

Remarks

The model is discrete. Good simulation results have been obtained with a $2 \mu s$ time step. To simulate a digital controller device, the control system has two different sampling times:

Field-Oriented Control Induction Motor Drive

- Speed controller sampling time
- FOC sampling time

The speed controller sampling time has to be a multiple of the FOC sampling time. The latter sampling time has to be a multiple of the simulation time step. The average-value inverter allows the use of bigger simulation time steps since it does not generate small time constants (due to the RC snubbers) inherent to the detailed converter. For an FOC sampling time of $60 \mu\text{s}$, good simulation results have been obtained for a simulation time step of $60 \mu\text{s}$. This time step can, of course, not be higher than the FOC time step.

Field-Oriented Control Induction Motor Drive

Dialog Box

Asynchronous Machine Tab

The screenshot shows a software dialog box titled "Field-Oriented Control Induction Motor Drive". It features a tabbed interface with three tabs: "Asynchronous Machine" (selected), "Converters and DC bus", and "Controller".

Below the tabs, there is a text box with the following text: "The AC motor parameters are specified in the AC Machine tab. The braking chopper, the diode rectifier and the inverter switches parameters are specified in the Converter and DC bus tab. F.O.C. and speed controller parameters are specified in the Controller Tab."

The "Asynchronous Machine" tab is divided into several sections:

- Electrical parameters:**
 - Reference frame:
 - Nominal values:**
 - Power (VA):
 - Voltage (Vrms):
 - Frequency (Hz):
 - Equivalent circuit values:**
 - Resistance (ohm):
 - Stator:
 - Rotor:
 - Leakage inductance (H):
 - Stator:
 - Rotor:
 - Mutual inductance (H):
 - Initial currents:**

	Phase A:	Phase B:	Phase C:
Magnitude (A):	<input type="text" value="0"/>	<input type="text" value="0"/>	<input type="text" value="0"/>
Phase (deg):	<input type="text" value="0"/>	<input type="text" value="0"/>	<input type="text" value="0"/>
- Mechanical parameters:**
 - Rotor values:**
 - Inertia (kg*m²):
 - Friction (N-m-s):
 - Pole pairs:
 - Initial values:**
 - Slip:
 - Angle (deg):

At the bottom of the dialog, there is a "Model detail level:" dropdown menu set to "Detailed". Below that is a "Parameters file options" section with "Load" and "Save" buttons. At the very bottom are "OK", "Cancel", "Help", and "Apply" buttons.

The **Asynchronous Machine** tab displays the parameters of the asynchronous machine block of the powerlib library. Refer to the Asynchronous Machine for more information on the Asynchronous Machine parameters.

Field-Oriented Control Induction Motor Drive

Converters and DC Bus Tab

Field-Oriented Control Induction Motor Drive

The AC motor parameters are specified in the AC Machine tab. The braking chopper, the diode rectifier and the inverter switches parameters are specified in the Converter and DC bus tab. F.O.C. and speed controller parameters are specified in the Controller Tab.

Asynchronous Machine **Converters and DC bus** Controller

Rectifier

Snubbers

Resistance (ohm): 10e3

Capacitance (F): 20e-9

Diodes

On-state resistance (ohm): 1e-3

Forward voltage (V): 1.3

DC Bus

Capacitance (F): 1500e-6

Braking chopper

Resistance (ohm): 8

Chopper frequency (Hz): 4000

Activation voltage (V): 340

Shutdown voltage (V): 320

Inverter

Switches

Device type: IGBT / Diodes

On-state resistance (ohm): 1e-3

Forward voltages (V)

Main device: 0.8

Diode: 0.8

Turn-off characteristics

Fall time (s): 1e-6

Tail time (s): 2e-6

Snubbers

Resistance (ohm): 5e3

Capacitance (F): inf

Model detail level: Detailed

Parameters file options

Load Save

OK Cancel Help Apply

Rectifier Section

The **Rectifier** section of the **Converters and DC Bus** tab displays the parameters of the Universal Bridge block of the powerlib library. Refer to the Universal Bridge for more information on the universal bridge parameters.

Inverter Section

The **Inverter** section of the **Converters and DC Bus** tab displays the parameters of the Universal Bridge block of the powerlib library. Refer to the Universal Bridge for more information on the universal bridge parameters.

Field-Oriented Control Induction Motor Drive

The average-value inverter uses the following parameters.

Source frequency

The frequency of the three-phase voltage source (Hz).

On-state resistance

The on-state resistance of the inverter devices (ohms).

DC Bus Field — Capacitance

The DC bus capacitance (F).

Braking Chopper section

Resistance

The braking chopper resistance used to avoid bus over-voltage during motor deceleration or when the load torque tends to accelerate the motor (ohms).

Frequency

The braking chopper frequency (Hz).

Activation Voltage

The dynamic braking is activated when the bus voltage reaches the upper limit of the hysteresis band (V). The following figure illustrates the braking chopper hysteresis logic.

Deactivation Voltage

The dynamic braking is shut down when the bus voltage reaches the lower limit of the hysteresis band (V). The Chopper hysteresis logic is shown in the next figure.

Field-Oriented Control Induction Motor Drive

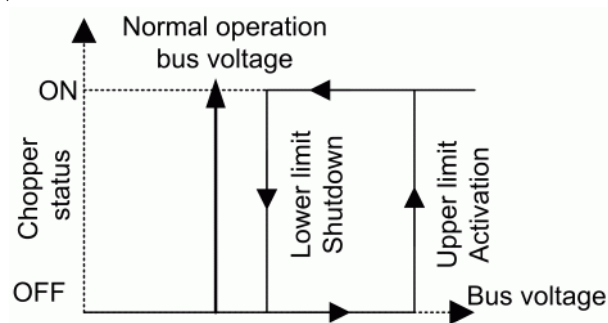

Controller Tab

Field-Oriented Control Induction Motor Drive

The AC motor parameters are specified in the AC Machine tab. The braking chopper, the diode rectifier and the inverter switches parameters are specified in the Converter and DC bus tab. F.O.C. and speed controller parameters are specified in the Controller Tab.

Asynchronous Machine Converters and DC bus **Controller**

Regulation type: Schematic

Speed controller

Speed ramps (rpm/s)	Speed cutoff frequency (Hz)	Speed controller sampling time (s)
Acceleration: <input type="text" value="1800"/> Deceleration: <input type="text" value="-1800"/>	<input type="text" value="100"/>	<input type="text" value="100e-6"/>

Machine flux (Wb)

Initial: <input type="text" value="0.3"/>
Nominal: <input type="text" value="0.3"/>

PI regulator

Proportional gain: <input type="text" value="5"/>	Integral gain: <input type="text" value="10"/>
---	--

Torque output limits (N-m)

Negative: <input type="text" value="-17.8"/>	Positive: <input type="text" value="17.8"/>
--	---

Field oriented control

Flux controller

Proportional gain: <input type="text" value="40"/>	Integral gain: <input type="text" value="50"/>
--	--

Flux output limits (Wb)

Negative: <input type="text" value="-2"/>	Positive: <input type="text" value="2"/>
---	--

Lowpass filter cutoff frequency (Hz): Sampling time (s):

Current controller hysteresis band (A): Maximum switching frequency (Hz):

Model detail level:

Parameters file options

Field-Oriented Control Induction Motor Drive

Regulation Type

This pop-up menu allows you to choose between speed and torque regulation.

Schematic Button

When you press this button, a diagram illustrating the speed and current controllers schematics appears.

Speed Controller section

Speed Sensor Cutoff Frequency

The speed measurement first-order low-pass filter cutoff frequency (Hz).

Sampling Time

The speed controller sampling time (s). The sampling time must be a multiple of the simulation time step.

Speed Ramps — Acceleration

The maximum change of speed allowed during motor acceleration. An excessively large positive value can cause DC bus under-voltage (rpm/s).

Speed Ramps — Deceleration

The maximum change of speed allowed during motor deceleration. An excessively large negative value can cause DC bus over-voltage (rpm/s).

Proportional Gain

The speed controller proportional gain.

Integral Gain

The speed controller integral gain.

Output Limits — Negative

The maximum negative demanded torque applied to the motor by the FOC controller (N.m).

Output Limits — Positive

The maximum positive demanded torque applied to the motor by the FOC controller (N.m).

Field-Oriented Control Induction Motor Drive

FOC Section

Maximum Switching Frequency

The maximum inverter switching frequency (Hz).

Initial Machine Flux

The desired initial rotor flux established before the F.O.C. module begins to produce an electromagnetic torque. This flux is created by a modulated voltage vector at the motor terminals (Wb).

Nominal Machine Flux

The motor nominal flux (Wb).

Sampling Time

The F.O.C. controller sampling time (s). The sampling time must be a multiple of the simulation time step.

Hysteresis Bandwidth — Current

The current hysteresis bandwidth. This value is the total bandwidth distributed symmetrically around the current set point (A). The following figure illustrates a case where the current set point is I_s^* and the current hysteresis bandwidth is set to dx .

This parameter is not used when using the average-value inverter.

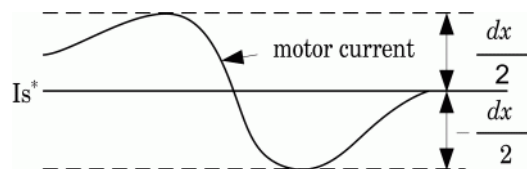

Flux Controller Section

Proportional Gain

The flux controller proportional gain.

Integral Gain

The flux controller integral gain.

First-Order Low-Pass Cutoff Frequency

The flux estimation first-order filter cutoff frequency (Hz).

Field-Oriented Control Induction Motor Drive

Block Inputs and Outputs

Output Limit — Positive

The flux controller maximum positive output (Wb).

Output Limit — Negative

The flux controller maximum negative output (Wb).

SP

The speed or torque set point. Note that the speed set point can be a step function, but the speed change rate will follow the acceleration / deceleration ramps. If the load torque and the speed have opposite signs, the accelerating torque will be the sum of the electromagnetic and load torques.

Mec_T

The mechanical load torque input.

A, B, C

The three phase terminals of the motor drive.

Motor

The motor measurement vector. This vector allows you to observe the motor's variables using the Bus Selector block.

Conv

The three-phase converters measurement vector. This vector contains:

- The DC bus voltage
- The rectifier output current
- The inverter input current

Note that all current and voltage values of the bridges can be visualized with the Multimeter block.

Ctrl

The controller measurement vector. This vector contains:

- The torque reference
- The speed error (difference between the speed reference ramp and actual speed)
- The speed reference ramp or torque reference

Field-Oriented Control Induction Motor Drive

Model Specifications

The library contains a 3 hp and a 200 hp drive parameter set. The specifications of these two drives are shown in the following table.

3 HP and 200 HP Drive Specifications

		3 HP Drive	200 HP Drive
Drive Input Voltage	Amplitude	220 V	460 V
	Frequency	60 Hz	60 Hz
	Motor Nominal Values		
	Power	3 hp	200 hp
	Speed	1705 rpm	1785 rpm
	Voltage	220 V	460 V

Example

The ac3_example demo illustrates an AC3 motor drive simulation with standard load conditions for the detailed and average-value models.

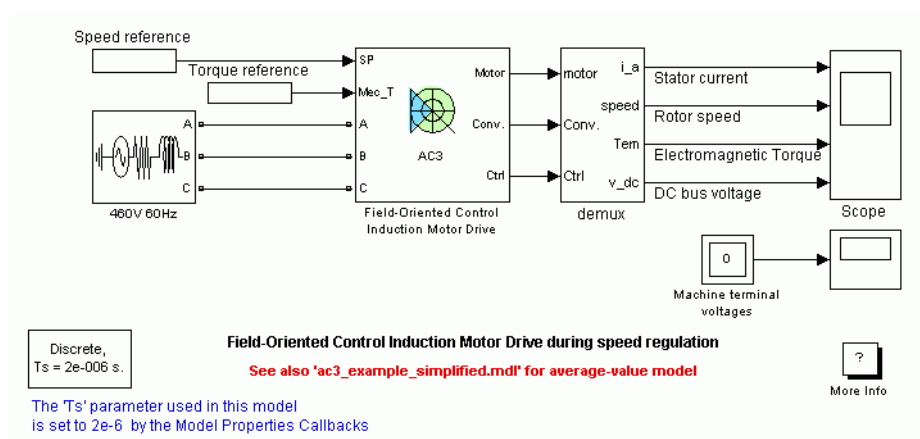

Field-Oriented Control Induction Motor Drive

At time $t = 0$ s, the speed set point is 500 rpm. As shown in the following figure, the speed precisely follows the acceleration ramp. At $t = 0.5$ s, the nominal load torque is applied to the motor. At $t = 1$ s, the speed set point is changed to 0 rpm. The speed decreases to 0 rpm. At $t = 1.5$ s, the mechanical load passes from 792 N.m to -792 N.m. Notice that the results of the average-value model are similar to those of the detailed model except that the higher frequency signal components are not represented with the average-value converter.

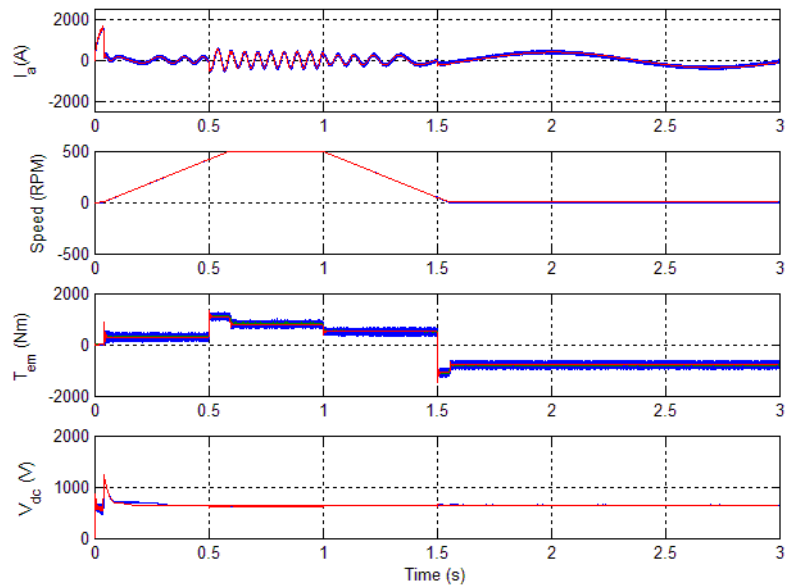

AC3 Example Waveforms (Blue : Detailed Converter, Red : Average-Value Converter)

References

- [1] Bose, B. K., *Modern Power Electronics and AC Drives*, Prentice-Hall, N.J., 2002.
- [2] Grelet, G., and G. Clerc, *Actionneurs électriques*, Éditions Eyrolles, Paris, 1997.
- [3] Krause, P. C., *Analysis of Electric Machinery*, McGraw-Hill, 1986.

Fourier

Purpose Perform a Fourier analysis of a signal

Library Extras/Measurements

A discrete version of this block is available in the Extras/Discrete Measurements library.

Description

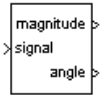

The Fourier block performs a Fourier analysis of the input signal over a running window of one cycle of the fundamental frequency of the signal. The Fourier block can be programmed to calculate the magnitude and phase of the DC component, the fundamental, or any harmonic component of the input signal.

Recall that a signal $f(t)$ can be expressed by a Fourier series of the form

$$f(t) = \frac{a_0}{2} + \sum_{n=1}^{\infty} a_n \cos(n\omega t) + b_n \sin(n\omega t)$$

where n represents the rank of the harmonics ($n = 1$ corresponds to the fundamental component). The magnitude and phase of the selected harmonic component are calculated by the following equations:

$$|H_n| = \sqrt{a_n^2 + b_n^2} \quad \angle H_n = \text{atan}\left(\frac{b_n}{a_n}\right)$$

where

$$a_n = \frac{2}{T} \int_{(t-T)}^t f(t) \cos(n\omega t) dt \quad b_n = \frac{2}{T} \int_{(t-T)}^t f(t) \sin(n\omega t) dt$$
$$T = \frac{1}{f_1} \quad f_1: \text{Fundamental frequency}$$

As this block uses a running average window, one cycle of simulation has to be completed before the outputs give the correct magnitude and angle. The discrete version of this block allows you to specify the initial magnitude and phase of the output signal. For the first cycle of simulation the outputs are held to the values specified by the initial input parameter.

Dialog Box and Parameters

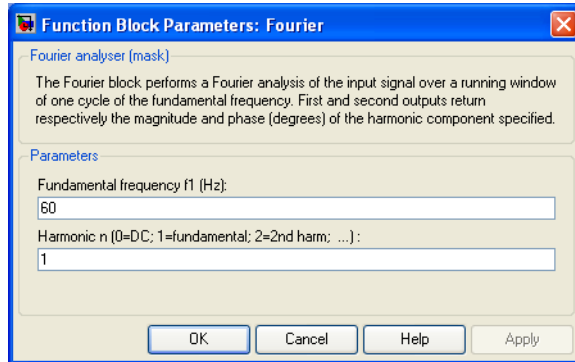

Fundamental frequency f1

The fundamental frequency, in hertz, of the input signal.

Harmonic n (0 = DC; 1 = fundamental; 2 = 2nd harm; etc.)

Specify the harmonic component you want to perform the Fourier analysis. Enter 0 if you want to analyze the DC component. Enter 1 if you want to analyze the fundamental frequency, or enter a number corresponding to the desired harmonic.

Inputs and Outputs

signal

Connect to the signal to be analyzed. Typical input signals are voltages or currents measured by Current Measurement blocks or Voltage Measurement blocks.

magnitude

The first output returns the magnitude of the harmonic component specified, in the same units as the input signal.

phase

The second output returns the phase, in degrees, of the harmonic component specified.

Example

The power_transfosat demo shows the energization of a 450 MVA three-phase transformer on a 500 kV network. The power system is simulated by an equivalent circuit consisting of an inductive source having a short-circuit power of 3000 MVA and a parallel RC load.

Fourier

The load capacitance is set to produce a resonance at 240 Hz (fourth harmonic). A Fourier block is used to measure the fourth harmonic content of phase A of the primary voltage.

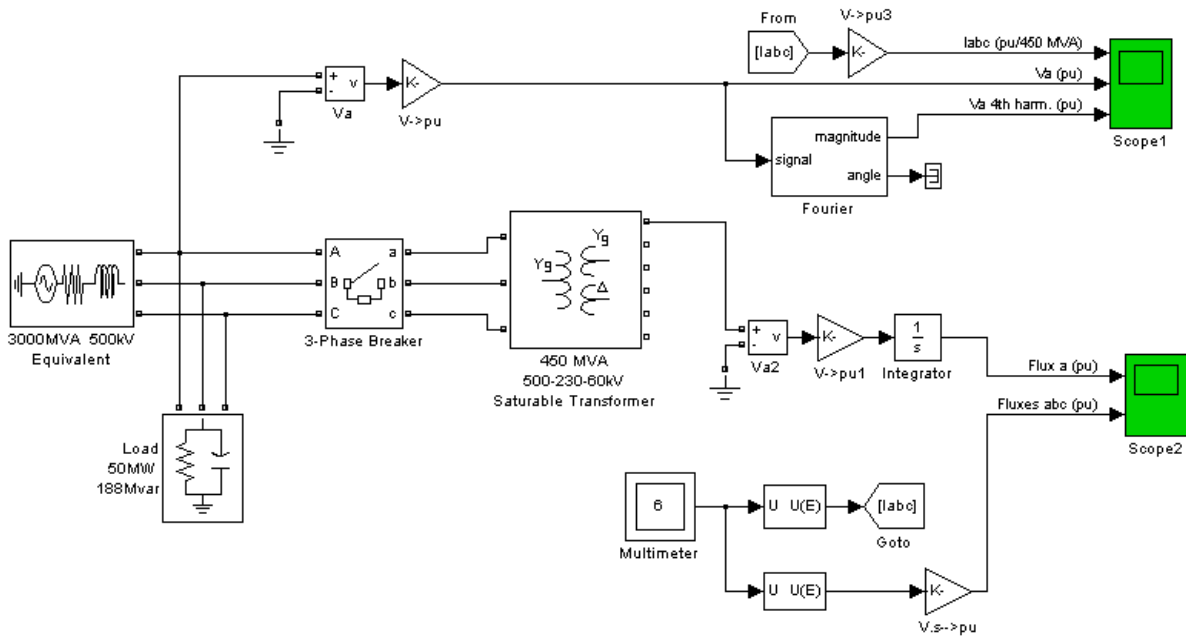

The Fourier block measures a high level fourth harmonic in the voltage (on the second trace of Scope1) because of the fourth harmonic content of the current injected into the network resonating at that particular frequency (240 Hz).

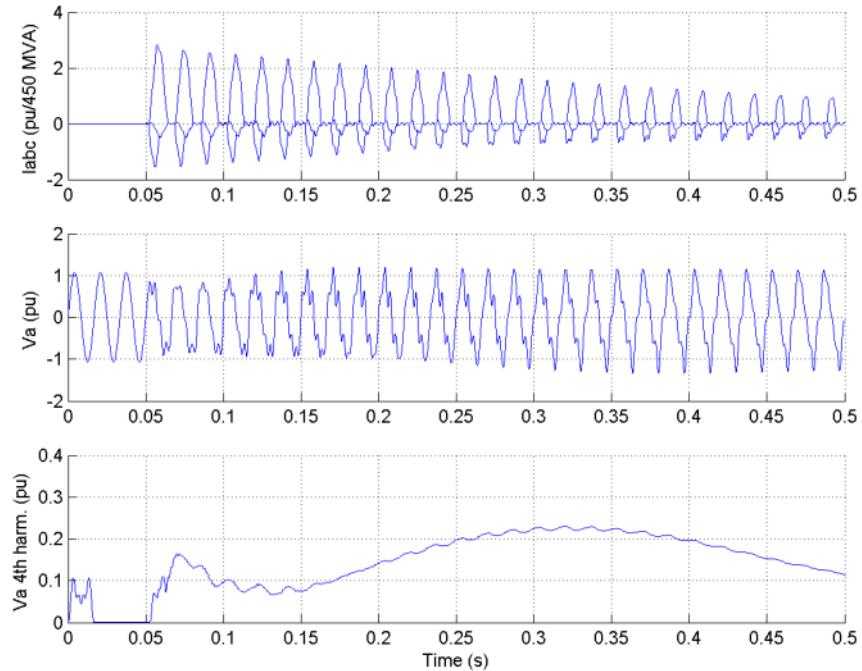

Four-Quadrant Chopper DC Drive

Purpose

Implement a four-quadrant chopper DC drive.

Library

Electric Drives/DC drives

Description

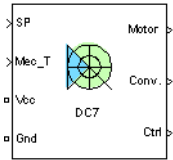

The high-level schematic shown below is built from four main blocks. The DC motor and the IGBT/Diode devices (within the Universal Bridge block) are provided with the SimPowerSystems library. More details on these two blocks are available in the reference sections of these blocks. The two other blocks are specific to the Electric Drives library. These blocks are the speed controller and the current controller. They allow speed or torque regulation. A “regulation switch” block allows you to toggle from one type of regulation to the other. During torque regulation the speed controller is disabled.

Note In SimPowerSystems, the Four-Quadrant Chopper DC Drive block is commonly called the DC7 motor drive.

High-Level Schematic

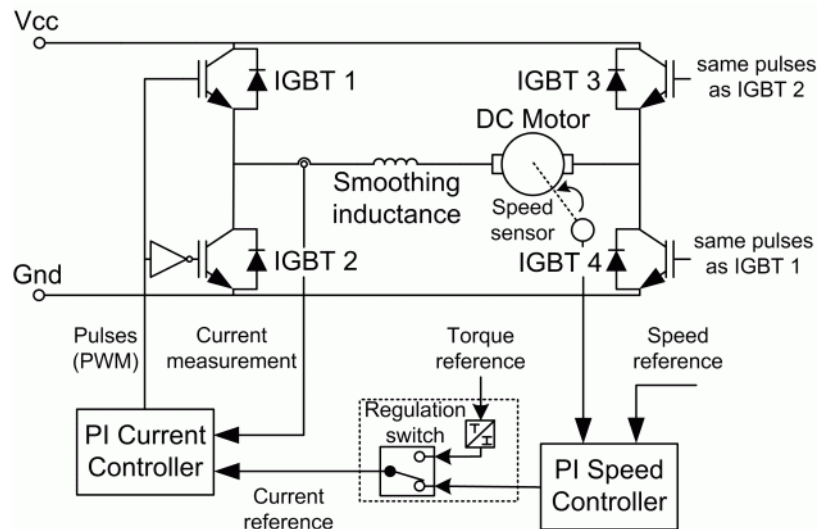

Four-Quadrant Chopper DC Drive

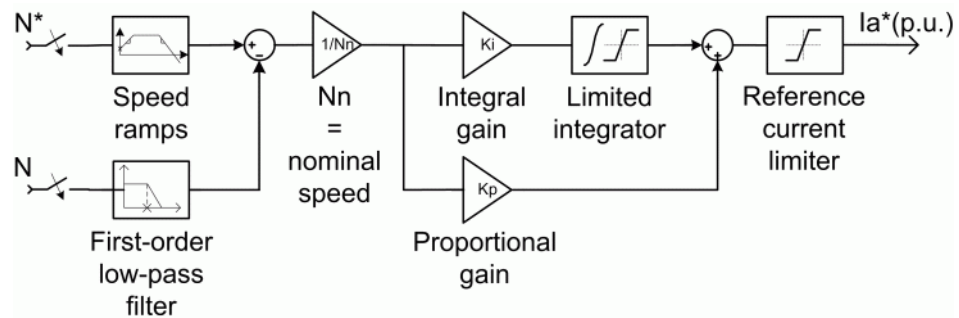

Current Controller

The armature current regulator shown below is based on a second PI controller. The regulator controls the armature current by computing the appropriate duty ratios of the fixed frequency pulses of the four IGBT devices (Pulse Width Modulation). This generates the average armature voltage needed to obtain the desired armature current and thus the desired electromagnetic torque. For proper system behavior, the instantaneous pulse values of IGBT devices 1 and 4 are the opposite of those of IGBT devices 2 and 3.

The controller takes the current reference (in p.u.) and the armature current flowing through the motor as inputs. The current reference is either provided by the speed controller during speed regulation or computed from the torque reference provided by the user during torque regulation. This is managed by the “regulation switch” block. The armature current input is filtered by a first-order low-pass filter.

The pulse width modulation is obtained by comparison of the PI output and a fixed frequency sawtooth carrier signal (as shown in the figure called “Pulse Width Modulation (PWM)” on page 7-127).

Four-Quadrant Chopper DC Drive

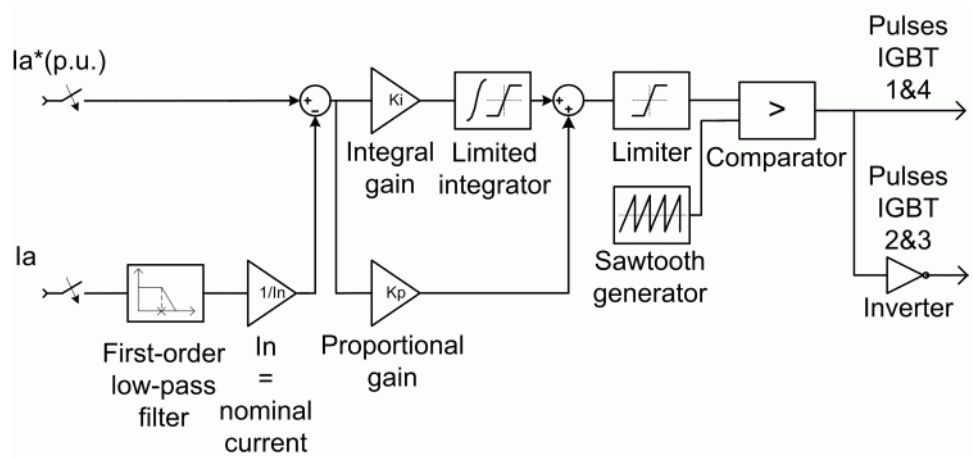

Four-Quadrant Chopper DC Drive

Average-Value Four-Quadrant Chopper

The average-value converter is shown in the following figure.

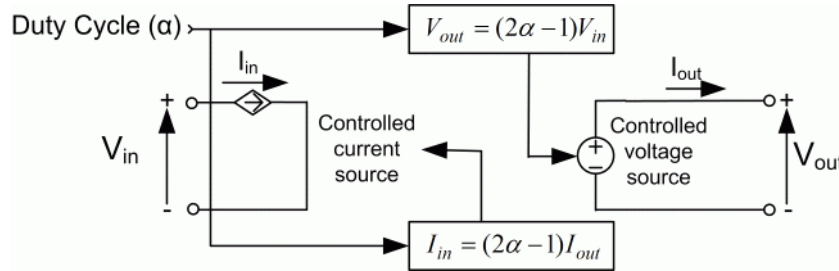

It is composed of one controlled current source on the DC source side and one controlled voltage source on the motor side. The current source allows the representation of the average input current value according to the following equation :

$$I_{in} = (2\alpha - 1)I_{out}$$

with α being the firing angle value and I_{out} the armature current value. The voltage source on the motor side represents the average voltage value according to the next equation :

$$V_{out} = (2\alpha - 1)V_{in}$$

with V_{in} being the input voltage.

Remarks

The machine is separately excited with a constant DC field voltage source. There is thus no field voltage control. By default, the field current is set to its steady-state value when a simulation is started.

The armature voltage is provided by an IGBT converter controlled by two PI regulators. The converter is fed by a constant DC voltage source. Armature current oscillations are reduced by a smoothing inductance connected in series with the armature circuit.

The model is discrete. Good simulation results have been obtained with a $1 \mu\text{s}$ time step. In order to simulate a digital controller device, the control system has two different sampling times:

- The speed controller sampling time

Four-Quadrant Chopper DC Drive

- The current controller sampling time

The speed controller sampling time has to be a multiple of the current sampling time. The latter sampling time has to be a multiple of the simulation time step.

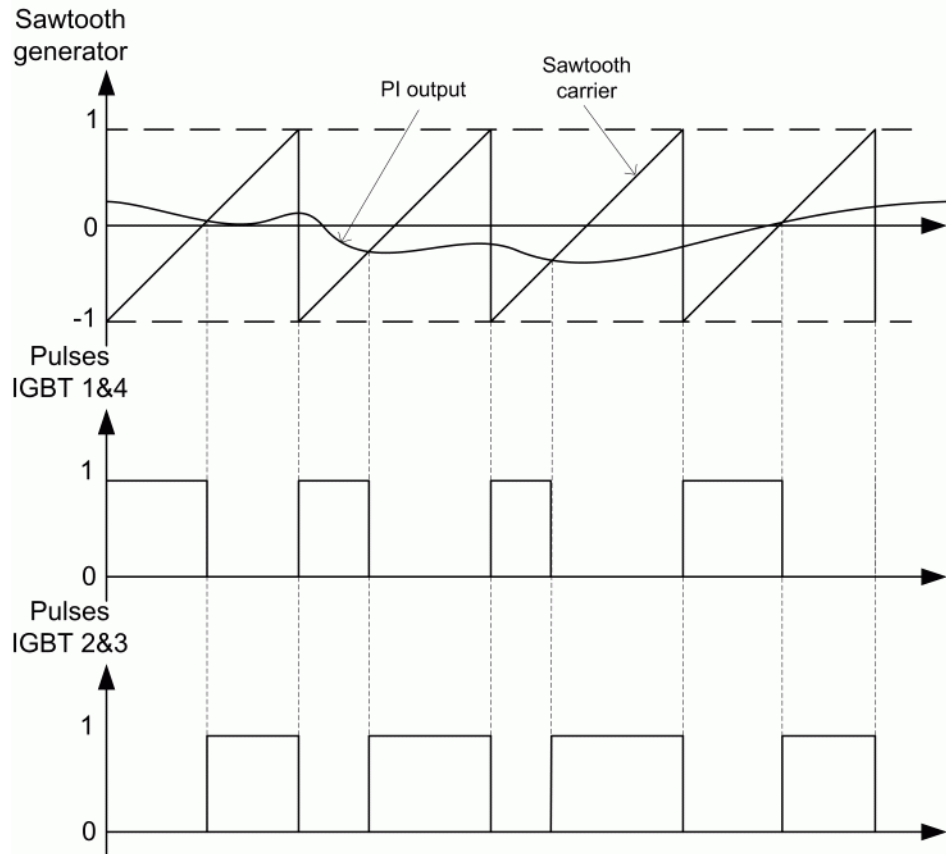

Figure 7-1: Pulse Width Modulation (PWM)

Four-Quadrant Chopper DC Drive

Dialog Box

DC Machine Tab

The screenshot shows a dialog box titled "4-Quadrant Chopper DC Motor Drive". The main text area contains the following information:

The DC motor parameters are specified in the DC Machine tab. The converter parameters, smoothing inductance and field voltage values are specified in the Converter tab. The speed and current regulator parameters are specified in the Controller tab.

The dialog box has three tabs: "DC Machine" (selected), "Converter", and "Controller".

Electrical parameters

- Mutual inductance (H): 1.234
- Armature**
 - Resistance (ohm): 0.78
 - Inductance (H): 0.016
- Field**
 - Resistance (ohm): 150
 - Inductance (H): 112.5

Mechanical parameters

- Inertia ($\text{kg}\cdot\text{m}^2$): 0.05
- Viscous friction coefficient (N-m-s): 0.01
- Coulomb friction torque (N-m): 0
- Initial speed (rad/s): 0

Model detail level: Detailed

Parameters file options: Load, Save

Buttons: OK, Cancel, Help, Apply

The DC Machine tab displays the parameters of the DC machine block of the powerlib library. Refer to the DC Machine for more information on the DC machine block parameters.

Converter Tab

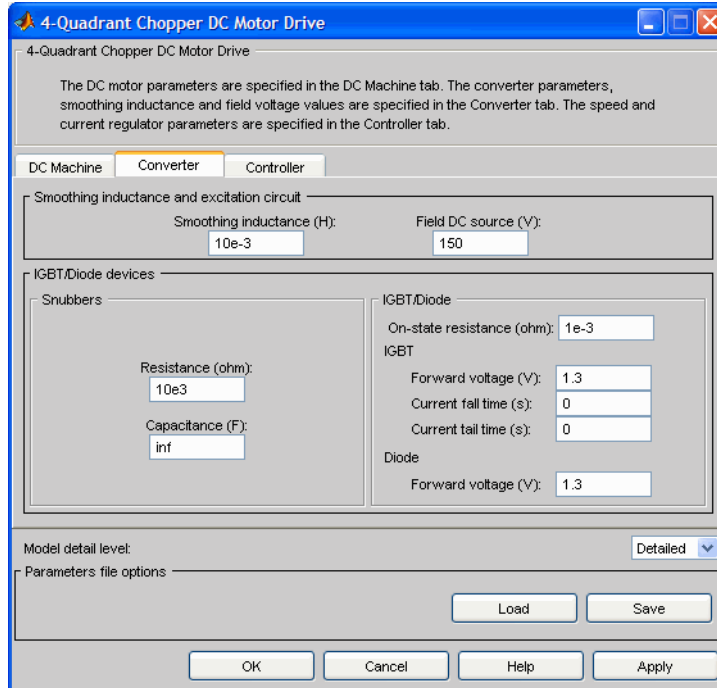

IGBT/Diode Devices section

The IGBT/Diode section of the Converter tab displays the parameters of the Universal Bridge block of the powerlib library. Refer to the Universal Bridge for more information on the Universal Bridge block parameters.

Smoothing Inductance

The smoothing inductance value (H).

Field DC Source

The DC motor field voltage value (V).

Four-Quadrant Chopper DC Drive

Controller Tab

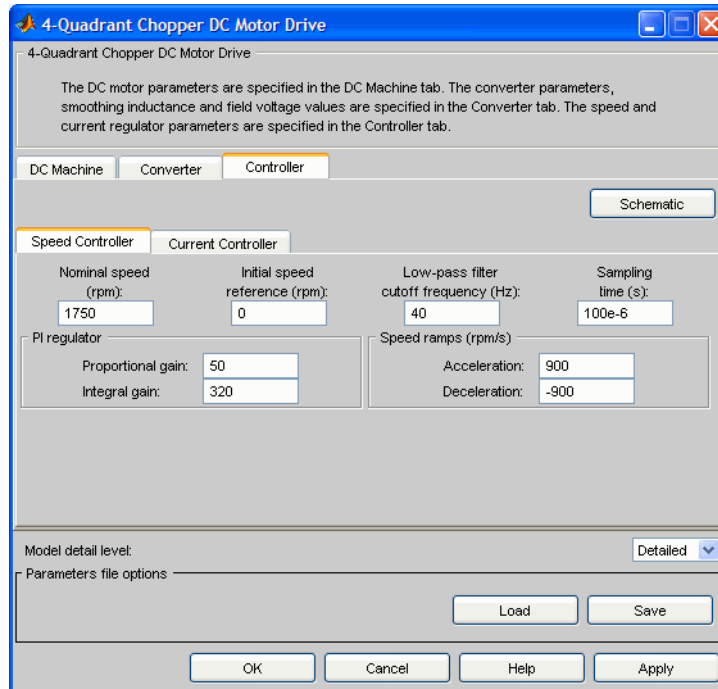

Schematic Button

When you press this button, a diagram illustrating the speed and current controllers schematics appears.

Regulation Type

This pop-up menu allows you to choose between speed and torque regulation.

Controller — Speed Controller Subtab

Nominal Speed

The nominal speed value of the DC motor (rpm). This value is used to convert motor speed from rpm to p.u. (per unit).

Initial Speed Reference

The initial speed reference value (rpm). This value allows the user to start a simulation with a speed reference other than 0 rpm.

Low-Pass Filter Cutoff Frequency

Cutoff frequency of the low-pass filter used to filter the motor speed measurement (Hz).

Sampling Time

The speed controller sampling time (s). This sampling time has to be a multiple of the current controller sampling time and of the simulation time step.

Proportional Gain

The proportional gain of the PI speed controller.

Integral Gain

The integral gain of the PI speed controller.

Acceleration

The maximum change of speed allowed during motor acceleration (rpm/s). Too great a value can cause armature over-current.

Deceleration

The maximum change of speed allowed during motor deceleration (rpm/s). Too great a value can cause armature over-current.

Four-Quadrant Chopper DC Drive

Controller — Current Controller Subtab

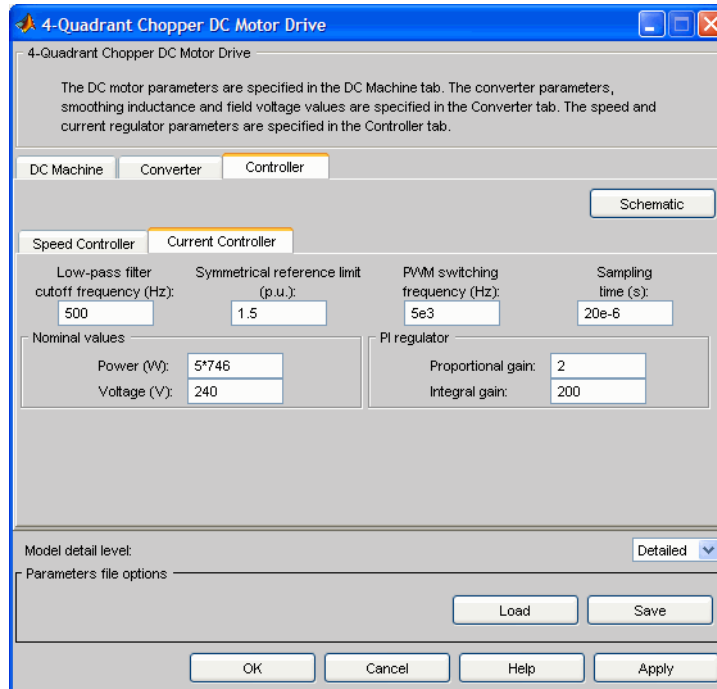

Low-Pass Filter Cutoff Frequency

Cutoff frequency of the low-pass filter used to filter the armature current measurement (Hz).

Symmetrical Reference Limit

Symmetrical current reference (p.u.) limit around 0 p.u. 1.5 p.u. is a common value.

PWM Switching Frequency

The switching frequency of the four IGBT devices (Hz).

Sampling Time

The current controller sampling time (s). This sampling time has to be a submultiple of the speed controller sampling time and a multiple of the simulation time step.

Block Inputs and Outputs

Power and Voltage nominal values

The DC motor nominal power (W) and voltage (V) values. These values are used to convert armature current from amperes to p.u. (per unit).

Proportional Gain

The proportional gain of the PI current controller.

Integral Gain

The integral gain of the PI current controller.

SP

The speed or torque set point. Note that the speed set point can be a step function, but the speed change rate will follow the acceleration / deceleration ramps.

Mec_T

The mechanical load torque input. If the load torque and the speed have opposite signs, the accelerating torque will be the sum of the electromagnetic and load torques.

Vcc, Gnd

The DC voltage source electric connections. The voltage must be adequate for the motor size.

Motor

The motor measurement vector. This vector is composed of two elements:

- The armature voltage
- The DC motor measurement vector (containing the speed, armature current, field current, and electromagnetic torque values). Note that the speed signal is converted from rad/s to rpm before output.

Conv

The IGBT/Diode device measurement vector. This vector includes the converter output voltage. The output current is not included since it is equal to the DC motor armature current. Note that all current and voltage values of the converter can be visualized with the Multimeter block.

Ctrl

The controller measurement vector. This vector contains:

- The armature current reference

Four-Quadrant Chopper DC Drive

- The duty cycle of the PWM pulses
- The speed or torque error (difference between the speed reference ramp and actual speed or between the torque reference and actual torque)
- The speed reference ramp or torque reference

Model Specifications

The library contains a 5 hp and a 200 hp drive parameter set. The specifications of these two drives are shown in the following table.

5 HP and 200 HP Drive Specifications

		5 HP Drive	200 HP Drive
Drive Input Voltage			
	Amplitude	280 V	500 V
Motor Nominal Values			
	Power	5 hp	200 hp
	Speed	1750 rpm	1184 rpm
	Voltage	240 V	440 V

Example

The `dc7_example` demo illustrates the four-quadrant chopper drive used with the 200 hp drive parameter set during speed regulation. A 5 hp parameter set is also available in the library.

Four-Quadrant Chopper DC Drive

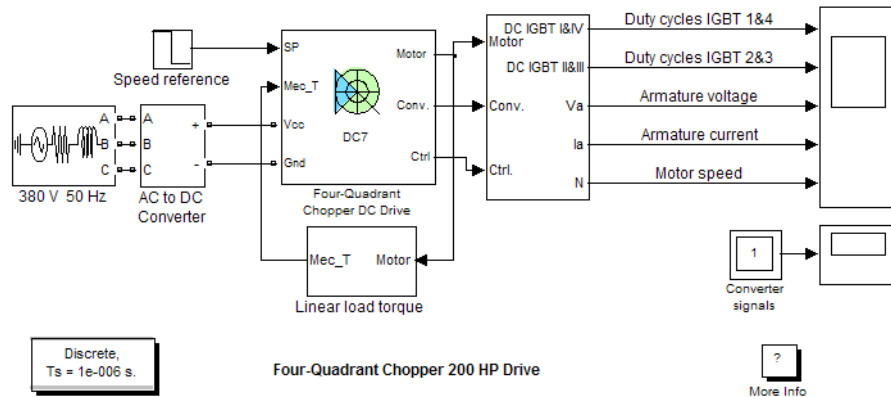

The converter is fed by a 515 V DC bus obtained by rectification of a 380 V AC 50 Hz voltage source. In order to limit the DC bus voltage during dynamic braking mode, a braking chopper has been added between the diode rectifier and the DC7 block. The IGBT switching frequency is 5 kHz.

The motor is coupled to a linear load, which means that the mechanical torque of the load is proportional to the speed.

The speed reference is set at 500 rpm at $t = 0$ s. Observe that the motor speed follows the reference ramp accurately (+400 rpm/s) and reaches steady state around $t = 1.3$ s.

The armature current follows the current reference very well, with fast response time and small ripples. Notice that the current ripple frequency is 5 kHz.

At $t = 2$ s, speed reference drops to -1184 rpm. The current reference decreases to reduce the electromagnetic torque and causes the motor to decelerate with the help of the load torque.

At $t = 2.2$ s, the current reverses in order to produce a braking electromagnetic torque (dynamic braking mode). This causes the DC bus voltage to increase.

At $t = 3.25$ s, the motor reaches 0 rpm and the load torque reverses and becomes negative. The negative current now produces an accelerating electromagnetic torque to allow the motor to follow the negative speed ramp (-400 rpm/s). At $t = 6.3$ s, the speed reaches -1184 rpm and stabilizes around its reference.

Four-Quadrant Chopper DC Drive

The following figure shows the DC bus voltage, armature current, and speed waveforms.

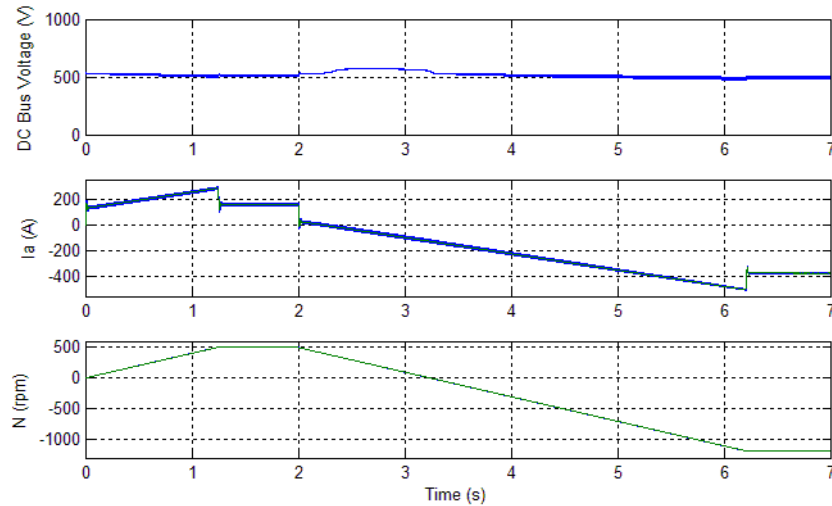

DC7 Example – DC Bus Voltage, Current, and Speed Waveforms

The next figure shows the duty cycles of the chopper pulses and the corresponding armature voltage and current waveforms during a time interval of 2 ms.

Four-Quadrant Chopper DC Drive

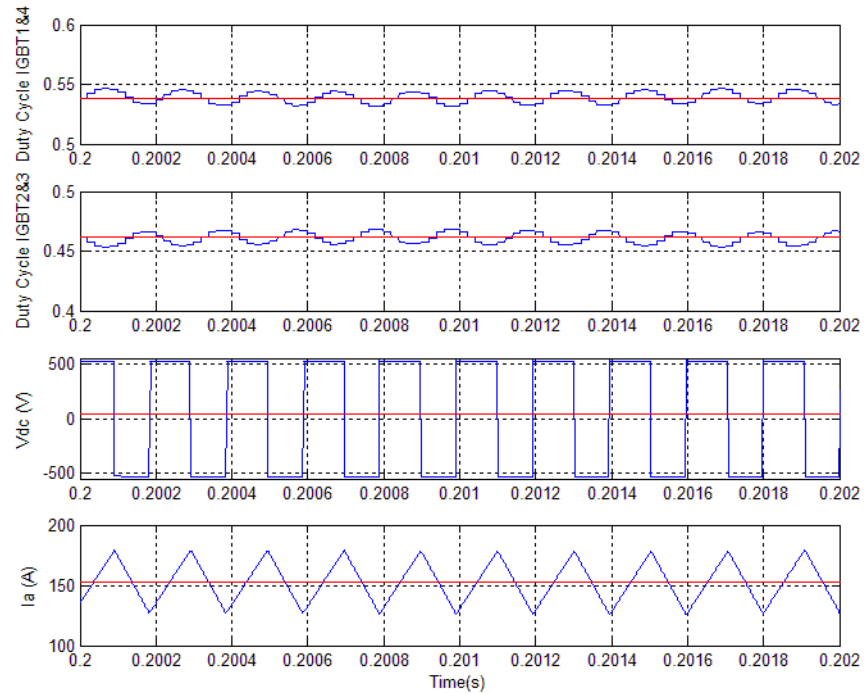

DC7 Example – Duty Cycles, Armature Voltage, and Current Waveforms

References

- [3] Boldea, Ion, and S.A. Nasar, *Electric Drives*, CRC Press LLC, 1999.
- [4] Séguier, Guy, *Electronique de puissance*, Dunod, 1999.

Four-Quadrant Single-Phase Rectifier DC Drive

Purpose

Implement a single-phase dual-converter DC drive with circulating current

Library

Electric Drives/DC drives

Description

The high-level schematic shown below is built from six main blocks. The DC motor, the two single-phase full converters, and the bridge firing unit are provided with the SimPowerSystems library. More details on these blocks are available in the reference sections of these blocks. The two other blocks are specific to the Electric Drives library. These blocks are the speed controller and the current controller. They allow speed or torque regulation. A “regulation switch” block allows you to toggle from one type of regulation to the other. During torque regulation the speed controller is disabled. It is possible to use a simplified version of the drive, which contains an average-value model of the single-phase dual-converter and allows faster simulation.

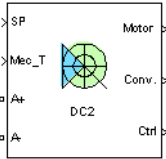

Note In SimPowerSystems, the Four-Quadrant Single-Phase Rectifier DC Drive block is commonly called the DC2 motor drive.

High-Level Schematic

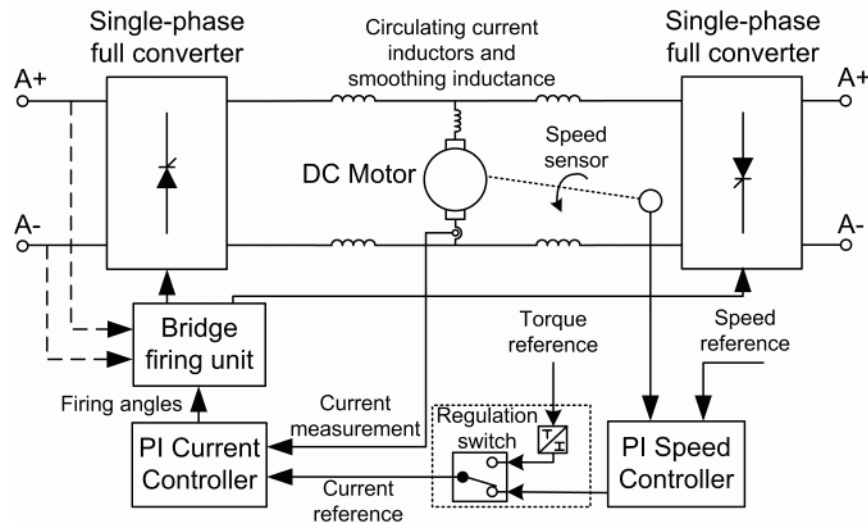

Four-Quadrant Single-Phase Rectifier DC Drive

Simulink Schematic

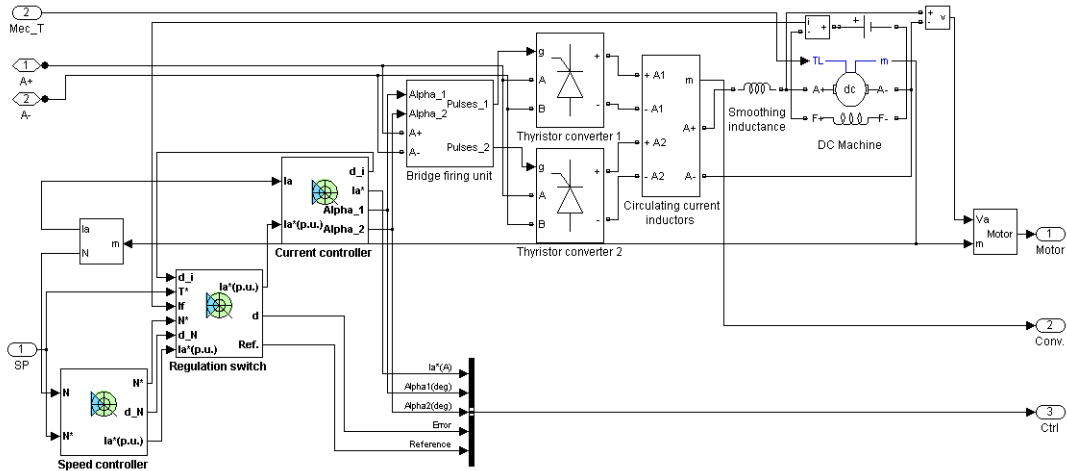

Speed Controller

The speed regulator shown below uses a PI controller. The controller outputs the armature current reference (in p.u.) used by the current controller in order to obtain the electromagnetic torque needed to reach the desired speed. During torque regulation, the speed controller is disabled.

The controller takes the speed reference (in rpm) and the rotor speed of the DC machine as inputs. The speed reference change rate will follow user-defined acceleration and deceleration ramps in order to avoid sudden reference changes that could cause armature over-current and destabilize the system. The speed measurement is filtered by a first-order low-pass filter.

The current reference output is limited between symmetrical lower and upper limits defined by the user.

Four-Quadrant Single-Phase Rectifier DC Drive

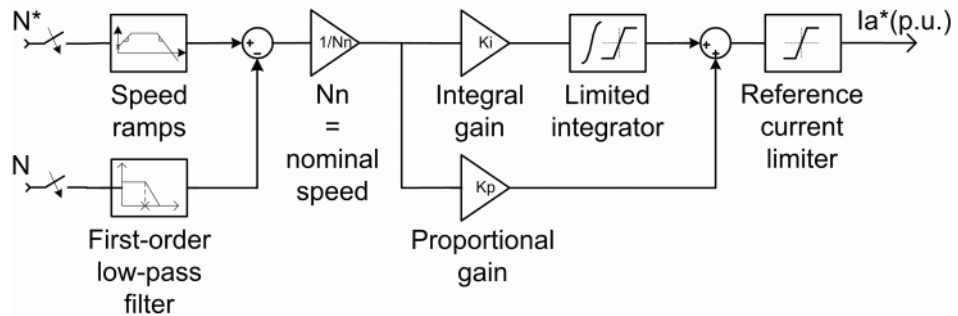

Current Controller

The armature current regulator shown below is based on a second PI controller. The regulator controls the armature current by computing the appropriate thyristor firing angles of the two full converters. This generates the converter output voltages needed to obtain the desired armature current and thus the desired electromagnetic torque.

The controller takes the current reference (in p.u.) and the armature current flowing through the motor as inputs. The current reference is either provided by the speed controller during speed regulation or computed from the torque reference provided by the user during torque regulation. This is managed by the “regulation switch” block.

The armature current input is filtered by a first-order low-pass filter. An arccosine function is used to linearize the control system. The firing angle can vary between 0 and 180 degrees. You can limit the lower and upper limits to intermediate values.

Both converters operate simultaneously, and the two firing angles are controlled so that the sum of their values stays equal to 180 degrees. This produces opposite average voltages at the converter DC output terminals and thus identical average voltages at the DC motor armature, the converters being connected in antiparallel. One converter is working in rectifier mode while the other is in inverter mode.

Four-Quadrant Single-Phase Rectifier DC Drive

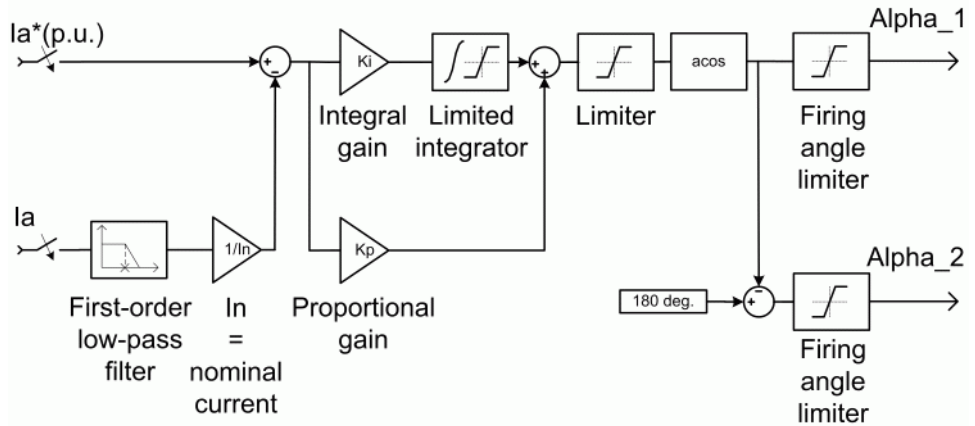

Average-Value Single-Phase Rectifier

The average-value single-phase rectifier with circulating current is shown in the following figure.

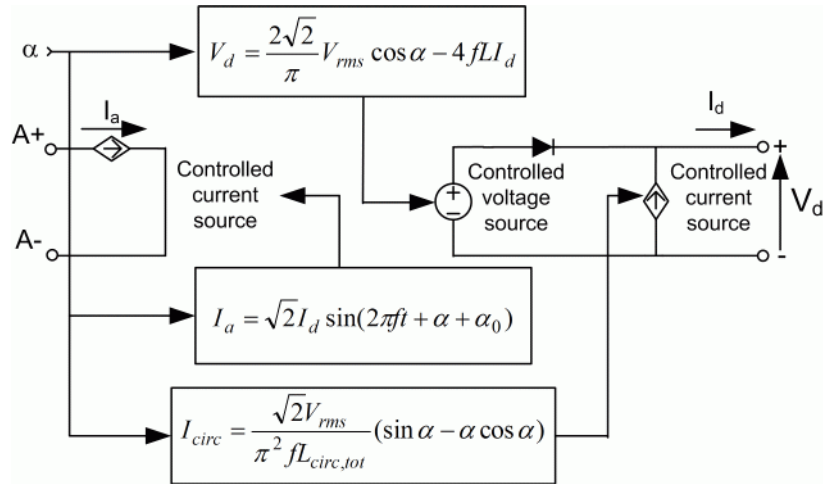

It is composed of one controlled current source on the AC side and one controlled voltage and current source on the DC side. The AC current source allows the representation of the fundamental single-phase current behavior according to the following equation

Four-Quadrant Single-Phase Rectifier DC Drive

$$I_d = \sqrt{2}I_d \sin(2\pi ft + \alpha + \alpha_0)$$

with α being the firing angle value, α_0 the phase angle of the AC side, f the AC frequency and I_d the rectified output current value. The DC voltage source represents the average voltage value of the rectified voltage waveform according to the next equation

$$V_d = \frac{2\sqrt{2}}{\pi} V_{rms} \cos \alpha - 4fLI_d$$

with V_{rms} being the input RMS voltage value and L being the source inductance value. The controlled current source represents the circulation current due to the instantaneous voltage difference between both converter outputs of the dual-converter. This current is equal to

$$I_{circ} = \frac{\sqrt{2}}{\pi^2 f L_{circ, tot}} V_{rms} (\sin \alpha - \alpha \cos \alpha)$$

with $L_{circ, tot}$ being the total circulation inductance of the circulation current loop.

Bridge Firing Unit

The bridge firing unit converts the firing angles, provided by the current controller, to two series of four pulses applied respectively to the thyristor gates of each converter. The bridge firing unit block contains a band-pass filter on voltage measurement to remove voltage harmonics. Two discrete synchronized pulse generator blocks generate the pulses of each converter. Their architecture is based on the Discrete Synchronized 6-Pulse Generator block. Refer to the Synchronized 6-Pulse Generator for more information on this block. When using the average-value converter, the bridge firing unit simply outputs the firing angle value needed by the converter.

Remarks

The machine is separately excited with a constant DC field voltage source. There is thus no field voltage control. By default, the field current is set to its steady-state value when a simulation is started.

The armature voltage is provided by two single-phase antiparallel-connected converters controlled by two PI regulators. The circulating current produced by the instantaneous voltage difference at the terminal of both converters is limited by inductors connected between these terminals. Armature current

Four-Quadrant Single-Phase Rectifier DC Drive

oscillations are reduced by a smoothing inductance connected in series with the armature circuit.

The average-value converter represents the average behavior of a single-phase rectifier for continuous armature current in a dual-converter topology. This model is thus not suitable for simulating DC drives under discontinuous armature current conditions. The converter outputs a continuous voltage value equal to the average-value of the real-life rectified voltage. The armature voltage, armature current and electromagnetic torque ripples are thus not represented. The input currents have the frequency and amplitude of the fundamental current component of the real-life input currents.

The model is discrete. Good simulation results have been obtained with a $4\ \mu\text{s}$ time step. The control system (speed and current controllers) samples data following a user-defined sample time in order to simulate a digital controller device. Keep in mind that this sampling time has to be a multiple of the simulation time step.

The average-value converter allows the use of bigger simulation time steps since it does not generate small time constants (due to the RC snubbers) inherent to the detailed converter. For a controller sampling time of $100\ \mu\text{s}$ good simulation results have been obtained for a simulation time step of $100\ \mu\text{s}$. This time step cannot be higher than the controller time step.

Four-Quadrant Single-Phase Rectifier DC Drive

Dialog Box

DC Machine Tab

The screenshot shows a dialog box titled "4-Quadrant Single-Phase Rectifier DC Motor Drive". The main text area contains the following instructions: "The DC motor parameters are specified in the DC Machine tab. The converter parameters, circulating current inductors, smoothing inductance and field voltage values are specified in the Converter tab. The bridge firing unit, speed and current regulator parameters are specified in the Controller tab." Below this text are three tabs: "DC Machine" (selected), "Converters", and "Controller".

The "DC Machine" tab is divided into two columns of parameters:

- Electrical parameters:**
 - Mutual inductance (H): 1.234
 - Armature:**
 - Resistance (ohm): 0.78
 - Inductance (H): 0.016
 - Field:**
 - Resistance (ohm): 150
 - Inductance (H): 112.5
- Mechanical parameters:**
 - Inertia ($\text{kg}\cdot\text{m}^2$): 0.05
 - Viscous friction coefficient (N-m-s): 0.01
 - Coulomb friction torque (N-m): 0
 - Initial speed (rad/s): 0

At the bottom of the dialog box, there is a "Model detail level" dropdown menu set to "Detailed". Below that is a "Parameters file options" section with "Load" and "Save" buttons. At the very bottom are "OK", "Cancel", "Help", and "Apply" buttons.

The DC Machine tab displays the parameters of the DC machine block of the powerlib library. Refer to the DC Machine for more information on the DC machine block parameters.

Four-Quadrant Single-Phase Rectifier DC Drive

Converter Tab

The screenshot shows a software window titled "4-Quadrant Single-Phase Rectifier DC Motor Drive". The window has three tabs: "DC Machine", "Converters", and "Controller". The "Converters" tab is active. The interface is divided into several sections:

- DC bus and Excitation circuit:** Contains three input fields: "Smoothing inductance (H):" with value "50e-3", "Field DC source (V):" with value "150", and "Circulating current inductors (H):" with value "80e-3".
- Converter 1 and Converter 2:** Each converter section has two sub-sections: "Snubbers" and "Thyristors".
 - Snubbers:** Includes "Resistance (ohm):" (2e3) and "Capacitance (F):" (900e-9).
 - Thyristors:** Includes "On-state resistance (ohm):" (1e-3) and "Forward voltage (V):" (1.3).
- External Voltage Source:** Includes "RMS voltage (V):" (320), "Frequency (Hz):" (60), "Source inductance (H):" (0.4e-3), and "Phase angle (deg):" (0).
- Model detail level:** A dropdown menu set to "Average".
- Parameters file options:** "Load" and "Save" buttons.
- Bottom buttons:** "OK", "Cancel", "Help", and "Apply".

Smoothing Inductance

The smoothing inductance value (H).

Field DC Source

The DC motor field voltage value (V).

Circulating Current Inductors

The four circulating current inductors inductance value (H).

Converter sections

The Converter 1 and Converter 2 sections of the Converter tab display the parameters of the Universal Bridge block of the powerlib library. Refer to the Universal Bridge for more information on the Universal Bridge block parameters.

Four-Quadrant Single-Phase Rectifier DC Drive

RMS Voltage

RMS voltage of the single-phase voltage source connected to the A+,A- terminals of the drive (V). This parameter is not used when using the detailed rectifier.

Frequency

Frequency of the single-phase voltage source connected to the A+,A- terminals of the drive (Hz). This parameter is not used when using the detailed rectifier.

Source Inductance

Source inductance of the single-phase voltage source connected to the A+,A- terminals of the drive (H). This parameter is not used when using the detailed rectifier.

Phase Angle

Phase angle of the single-phase voltage source connected to the A+,A- terminals of the drive (deg.). This parameter is not used when using the detailed rectifier.

Four-Quadrant Single-Phase Rectifier DC Drive

Controller Tab

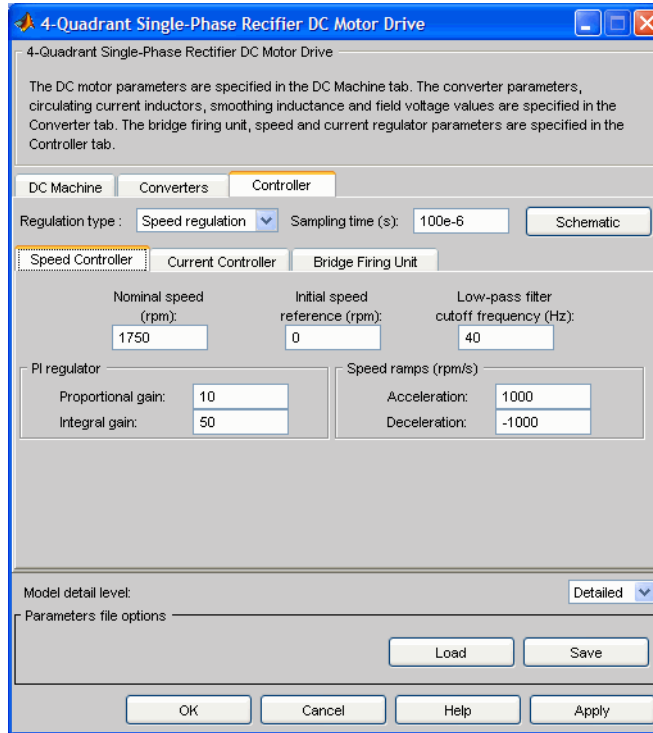

Schematic Button

When you press this button, a diagram illustrating the speed and current controllers schematics appears.

Regulation Type

This pop-up menu allows you to choose between speed and torque regulation.

Sampling Time

The controller (speed and current) sampling time (s). The sampling time has to be a multiple of the simulation time step.

Four-Quadrant Single-Phase Rectifier DC Drive

Controller — Speed Controller Subtab

Nominal Speed

The nominal speed value of the DC motor (rpm). This value is used to convert motor speed from rpm to p.u. (per unit).

Initial Speed Reference

The initial speed reference value (rpm). This value allows the user to start a simulation with a speed reference other than 0 rpm.

Low-Pass Filter Cutoff Frequency

Cutoff frequency of the low-pass filter used to filter the motor speed measurement (Hz).

Proportional Gain

The proportional gain of the PI speed controller.

Integral Gain

The integral gain of the PI speed controller.

Acceleration

The maximum change of speed allowed during motor acceleration (rpm/s). Too great a value can cause armature over-current.

Deceleration

The maximum change of speed allowed during motor deceleration (rpm/s). Too great a value can cause armature over-current.

Four-Quadrant Single-Phase Rectifier DC Drive

Controller — Current Controller Subtab

4-Quadrant Single-Phase Rectifier DC Motor Drive

The DC motor parameters are specified in the DC Machine tab. The converter parameters, circulating current inductors, smoothing inductance and field voltage values are specified in the Converter tab. The bridge firing unit, speed and current regulator parameters are specified in the Controller tab.

DC Machine Converters **Controller**

Regulation type : Speed regulation Sampling time (s): 100e-6 Schematic

Speed Controller **Current Controller** Bridge Firing Unit

Low-pass filter cutoff frequency (Hz): 50 Symmetrical reference limit (p.u.): 1.5

Nominal values

Power (W):	5*746
Voltage (V):	240

PI regulator

Proportional gain:	1
Integral gain:	80

Model detail level: Detailed

Parameters file options

Load Save

OK Cancel Help Apply

Power and Voltage nominal values

The DC motor nominal power (W) and voltage (V) values.

The nominal power and voltage values are used to convert armature current from amperes to p.u. (per unit).

Proportional Gain

The proportional gain of the PI current controller.

Integral Gain

The integral gain of the PI current controller.

Four-Quadrant Single-Phase Rectifier DC Drive

Low-Pass Filter Cutoff Frequency

Cutoff frequency of the low-pass filter used to filter the armature current measurement (Hz).

Symmetrical Reference Limit

Symmetrical current reference (p.u.) limit around 0 p.u. 1.5 p.u. is a common value.

Controller — Bridge Firing Unit Subtab

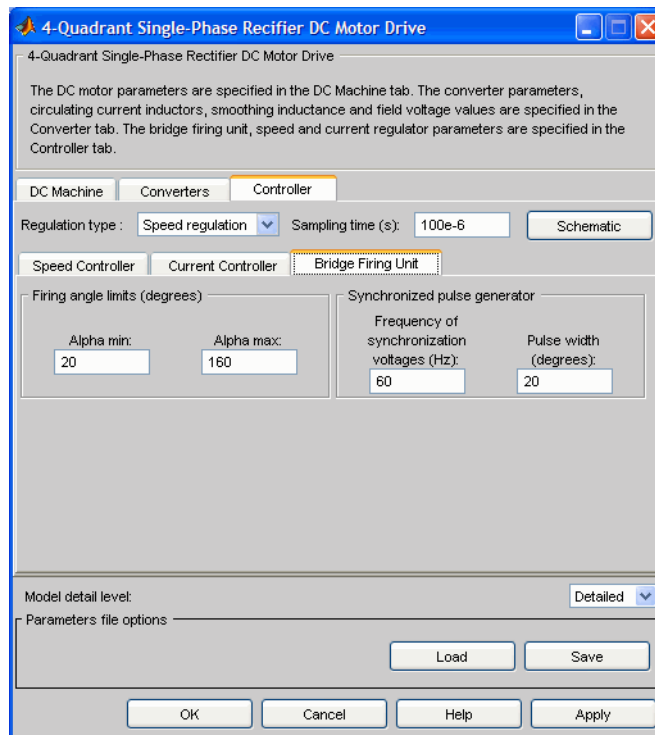

Alpha Min

Minimum firing angle value (deg.). 20 degrees is a common value.

Alpha Max

Maximum firing angle value (deg.). 160 degrees is a common value.

Four-Quadrant Single-Phase Rectifier DC Drive

Frequency of Synchronization Voltages

Frequency of the synchronization voltages used by the discrete synchronized pulse generator block (Hz). This frequency is equal to the line frequency of the single-phase power line. This parameter is not used when using the average-value converter.

Pulse Width

The width of the pulses applied to the thyristor gates (deg.). This parameter is not used when using the average-value converter.

Block Inputs and Outputs

SP

The speed or torque set point. Note that the speed set point can be a step function, but the speed change rate will follow the acceleration / deceleration ramps.

Mec_T

The mechanical load torque input. If the load torque and the speed have opposite signs, the accelerating torque will be the sum of the electromagnetic and load torques.

A+, A-

The single-phase electric connections. The applied voltage must be adequate for the motor size.

Motor

The motor measurement vector. It is composed of two elements:

- The armature voltage
- The DC motor measurement vector (containing the speed, armature current, field current, and electromagnetic torque values). Note that the speed signal is converted from rad/s to rpm before output.

Conv

The single-phase converter measurement vector. This vector includes

- The output voltage of converter 1
- The output voltage of converter 2
- The output current of converter 1
- The output current of converter 2

Four-Quadrant Single-Phase Rectifier DC Drive

Note that all current and voltage values of the detailed bridges can be visualized with the Multimeter block.

Ctrl

The controller measurement vector. This vector contains:

- The armature current reference
- The firing angle computed by the current controller
- The speed or torque error (difference between the speed reference ramp and actual speed or between the torque reference and actual torque)
- The speed reference ramp or torque reference

Model Specifications

The library contains a 5 hp drive parameter set. The specifications of the 5 hp drive are shown in the following table.

5 HP Drive Specifications

Drive Input Voltage		
	Amplitude	320 V
	Frequency	60 Hz
Motor Nominal Values		
	Power	5 hp
	Speed	1750 rpm
	Voltage	240 V

Example

The `dc2_example` demo illustrates the single-phase dual-converter drive used with the 5 hp drive parameter set during speed regulation. The converters are fed by a 230 V AC 60 Hz voltage source followed by a linear transformer to boost the voltage to a sufficient value.

Four-Quadrant Single-Phase Rectifier DC Drive

At $t = 14$ s, speed stabilizes at -600 rpm.

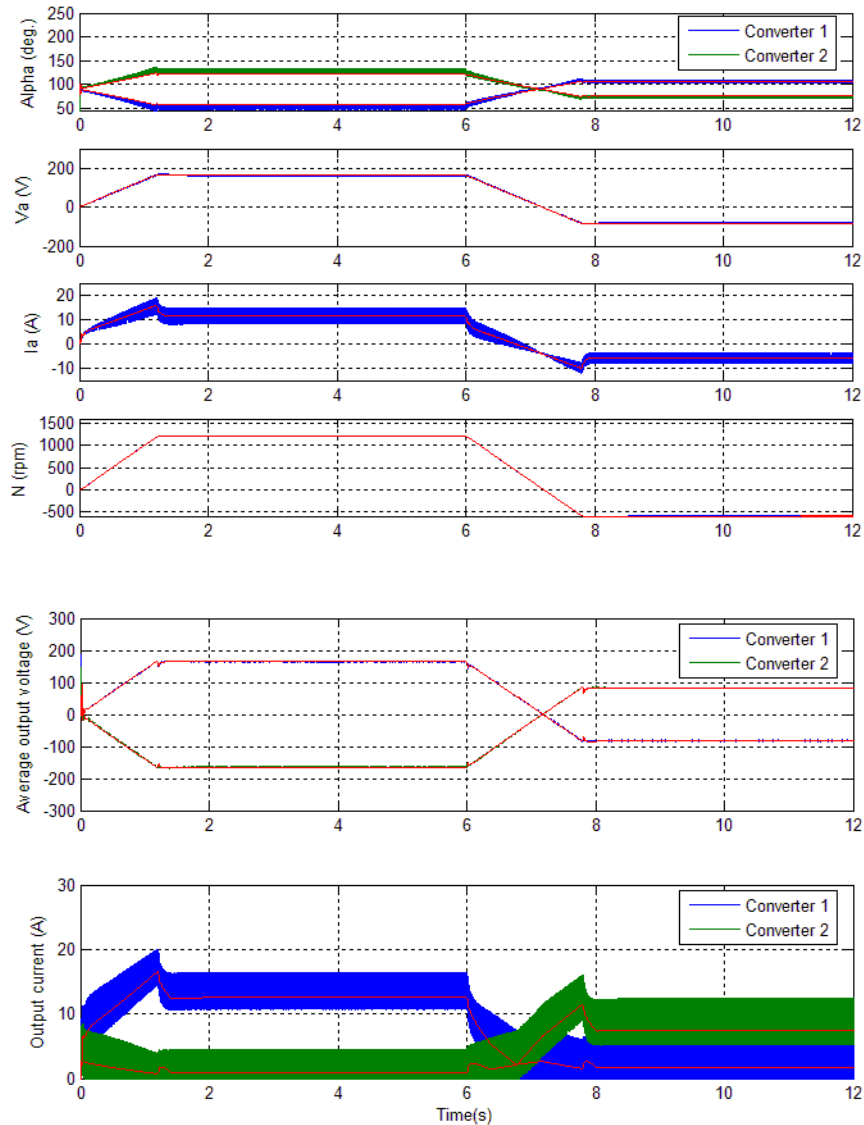

References

- [1] Sen, P.C., *Thyristor DC Drives*, J.Wiley and Sons, 1981.

Four-Quadrant Three-Phase Rectifier DC Drive

Purpose

Implement a three-phase dual-converter DC drive with circulating current

Library

Electric Drives/DC drives

Description

The high-level schematic shown below is built from six main blocks. The DC motor, the two three-phase full converters, and the bridge firing unit are provided with the SimPowerSystems library. More details on these blocks are available in the SimPowerSystems user guide. The two other blocks are specific to the Electric Drives library. These blocks are the speed controller and the current controller. They allow speed or torque regulation. A “regulation switch” block allows you to toggle from one type of regulation to the other. During torque regulation the speed controller is disabled. It is possible to use a simplified version of the drive containing an average-value model of the three-phase dual-converter and allowing faster simulation.

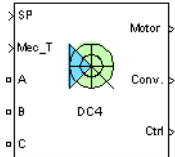

Note In SimPowerSystems, the Four-Quadrant Three-Phase Rectifier DC Drive block is commonly called the DC4 motor drive.

High-Level Schematic

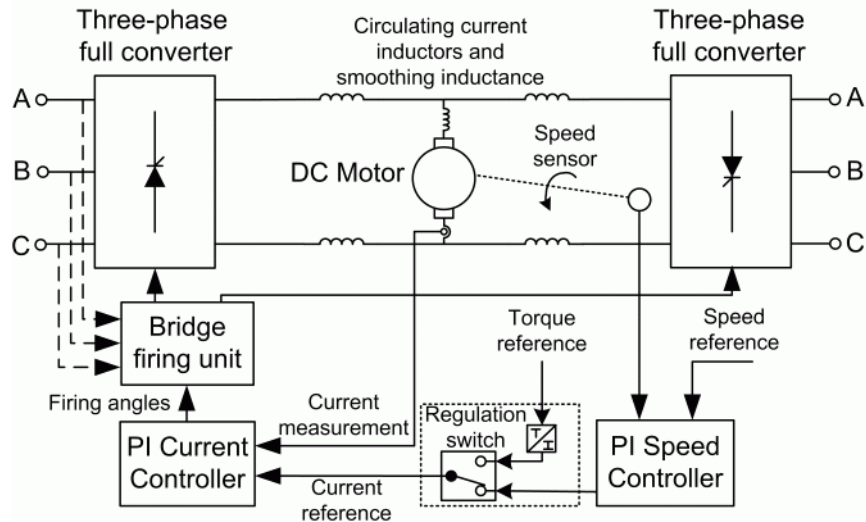

Four-Quadrant Three-Phase Rectifier DC Drive

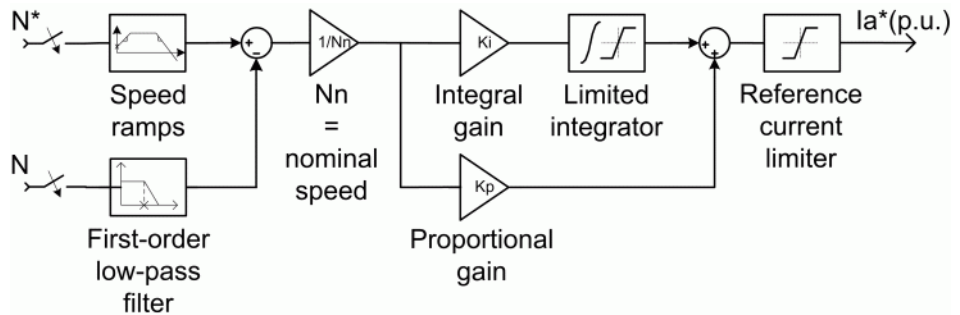

Current Controller

The armature current regulator shown below is based on a second PI controller. The regulator controls the armature current by computing the appropriate thyristor firing angles of the two full converters. This generates the converter output voltages needed to obtain the desired armature current and thus the desired electromagnetic torque.

The controller takes the current reference (in p.u.) and the armature current flowing through the motor as inputs. The current reference is either provided by the speed controller during speed regulation or computed from the torque reference provided by the user during torque regulation. This is managed by the “regulation switch” block.

The armature current input is filtered by a first-order low-pass filter. An arccosine function is used to linearize the control system. The firing angle can vary between 0 and 180 degrees. You can limit the lower and upper limits to intermediate values.

Both converters operate simultaneously, and the two firing angles are controlled so that the sum of their values stays equal to 180 degrees. This produces opposite average voltages at the converter DC output terminals and thus identical average voltages at the DC motor armature, the converters being connected in antiparallel. One converter is working in rectifier mode while the other is in inverter mode.

Four-Quadrant Three-Phase Rectifier DC Drive

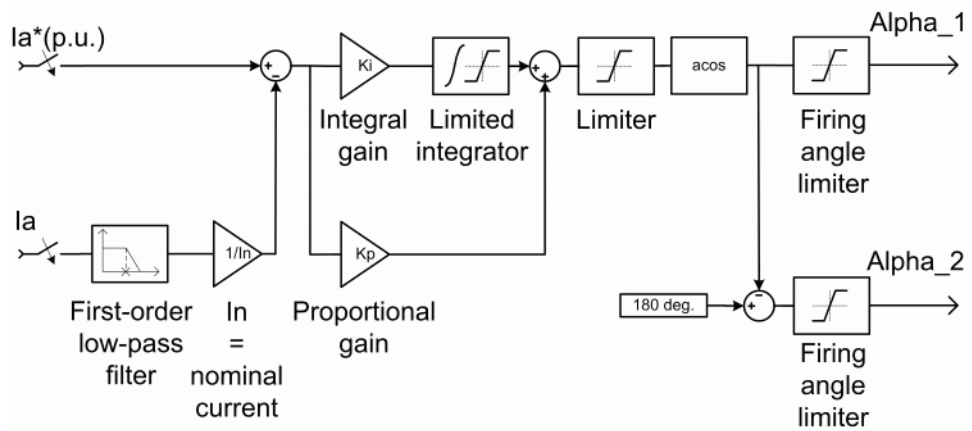

Average-Value Three-phase Rectifier

The simplified converter is shown in the following figure.

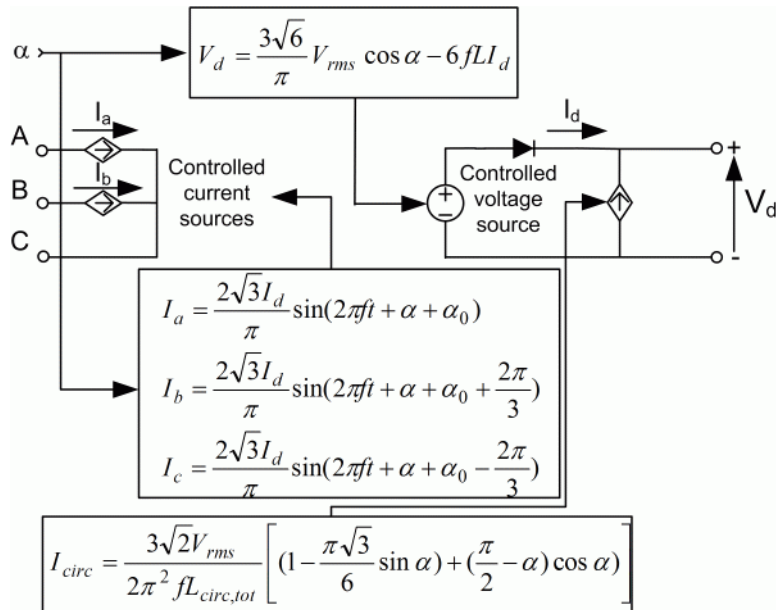

Average-Value Three-Phase Rectifier with Circulating Current

Four-Quadrant Three-Phase Rectifier DC Drive

It is composed of two controlled current sources on the AC side and one controlled voltage and current source on the DC side. The AC current sources allow the representation of the fundamental three-phase current behaviors according to the following equations

$$I_a = \frac{2\sqrt{3}}{\pi} I_d \sin(2\pi ft + \alpha + \alpha_0)$$

$$I_b = \frac{2\sqrt{3}}{\pi} I_d \sin\left(2\pi ft + \alpha + \alpha_0 + \frac{2\pi}{3}\right)$$

with α being the firing angle value, α_0 the phase angle of phase A, f the AC frequency and I_d the rectified output current value. The DC voltage source represents the average voltage value of the rectified voltage waveform according to the next equation

$$V_d = \frac{3\sqrt{6}}{\pi} V_{rms} \cos \alpha - 6fL I_d$$

with V_{rms} being the input phase-to-phase RMS voltage value and L being the source inductance value. The controlled current source represents the circulation current due to the instantaneous voltage difference between both converter outputs of the dual-converter. This current is equal to

$$V_d = \frac{3\sqrt{2}}{2\pi^2 f L_{circ, tot}} V_{rms} \left(1 - \frac{\pi\sqrt{3}}{6} \sin \alpha + \left(\frac{\pi}{2} - \alpha\right) \cos \alpha\right)$$

with $L_{circ, tot}$ being the total circulation inductance of the circulation current loop.

Bridge Firing Unit

The bridge firing unit converts the firing angles, provided by the current controller, to two series of six pulses applied respectively to the thyristor gates of each converter. The bridge firing unit block contains a band-pass filter on voltage measurement to remove voltage harmonics. Two Discrete Synchronized 6-Pulse Generator blocks generate the pulses. Refer to the Synchronized 6-Pulse Generator for more information on this block. When using the average-value converter, the bridge firing unit simply outputs the firing angle value needed by the converter.

Four-Quadrant Three-Phase Rectifier DC Drive

Remarks

The machine is separately excited with a constant DC field voltage source. There is thus no field voltage control. By default, the field current is set to its steady-state value when a simulation is started.

The armature voltage is provided by two three-phase antiparallel-connected converters controlled by two PI regulators. The circulating current produced by the instantaneous voltage difference at the terminal of both converters is limited by inductors connected between these terminals. No smoothing inductance is placed in series with the armature circuit, the armature current oscillations being quite small due to the three-phase voltage source.

The average-value converter represents the average behavior of a three-phase rectifier for continuous armature current in a dual-converter topology. This model is thus not suitable for simulating DC drives under discontinuous armature current conditions. The converter outputs a continuous voltage value equal to the average-value of the real-life rectified voltage. The armature voltage, armature current and electromagnetic torque ripples are thus not represented. The input currents have the frequency and amplitude of the fundamental current component of the real-life input currents.

The model is discrete. Good simulation results have been obtained with a 5 μs time step. The control system (speed and current controllers) samples data following a user-defined sample time in order to simulate a digital controller device. Keep in mind that this sampling time has to be a multiple of the simulation time step.

The average-value converter allows the use of bigger simulation time steps, since it does not generate small time constants (due to the RC snubbers) inherent to the detailed converter. For a controller sampling time of 100 μs good simulation results have been obtained for a simulation time step of 100 μs . This time step cannot be higher than the controller time step.

Four-Quadrant Three-Phase Rectifier DC Drive

Dialog Box

DC Machine Tab

The screenshot shows a dialog box titled "4-Quadrant Three-Phase Rectifier DC Motor Drive". It has three tabs: "DC Machine" (selected), "Converters", and "Controller". The "DC Machine" tab is divided into two columns: "Electrical parameters" and "Mechanical parameters".

Electrical parameters:

- Mutual inductance (H): 1.234
- Armature:**
 - Resistance (ohm): 0.78
 - Inductance (H): 0.016
- Field:**
 - Resistance (ohm): 150
 - Inductance (H): 112.5

Mechanical parameters:

- Inertia ($\text{kg}\cdot\text{m}^2$): 0.05
- Viscous friction coefficient (N-m-s): 0.01
- Coulomb friction torque (N-m): 0
- Initial speed (rad/s): 0

At the bottom, there is a "Model detail level" dropdown set to "Detailed" and a "Parameters file options" section with "Load" and "Save" buttons. At the very bottom are "OK", "Cancel", "Help", and "Apply" buttons.

The DC Machine tab displays the parameters of the DC machine block of the powerlib library. Refer to the DC Machine for more information on the DC machine block parameters.

Four-Quadrant Three-Phase Rectifier DC Drive

Converter Tab

The screenshot shows a software window titled "4-Quadrant Three-Phase Rectifier DC Motor Drive". The window contains several tabs: "DC Machine", "Converters" (which is selected), and "Controller". Below the tabs, there is a section for "DC bus and Excitation circuit" with input fields for "Field DC source (V):" (value: 150) and "Circulating current inductors (H):" (value: 50e-3). Below this, there are two sections for "Converter 1" and "Converter 2". Each converter section has sub-sections for "Snubbers" and "Thyristors". The "Snubbers" sub-sections have input fields for "Resistance (ohm):" (value: 9e3) and "Capacitance (F):" (value: 900e-9). The "Thyristors" sub-sections have input fields for "On-state resistance (ohm):" (value: 1e-3) and "Forward voltage (V):" (value: 1.3). Below the converter sections, there is an "External Voltage Source" section with input fields for "Phase-to-phase RMS voltage (V):" (value: 230), "Frequency (Hz):" (value: 60), "Source inductance (H):" (value: 0.1e-3), and "Phase angle of phase A (deg):" (value: 0). At the bottom of the window, there is a "Model detail level:" dropdown menu set to "Average" and a "Parameters file options" section with "Load" and "Save" buttons. At the very bottom, there are "OK", "Cancel", "Help", and "Apply" buttons.

Field DC Source

The DC motor field voltage value (V).

Circulating Current Inductors

The four circulating current inductors inductance value (H).

Converter sections

The Converter 1 and Converter 2 sections of the Converter tab display the parameters of the Universal Bridge block of the powerlib library. Refer to the Universal Bridge for more information on the Universal Bridge block parameters.

Four-Quadrant Three-Phase Rectifier DC Drive

Phase-to-Phase RMS Voltage

Phase-to-phase rms voltage of the three-phase voltage source connected to the A,B,C terminals of the drive (V). This parameter is not used when using the detailed rectifier.

Frequency

Frequency of the three-phase voltage source connected to the A,B,C terminals of the drive (Hz). This parameter is not used when using the detailed rectifier.

Source Inductance

Source inductance of the three-phase voltage source connected to the A,B,C terminals of the drive (H). This parameter is not used when using the detailed rectifier.

Phase Angle of Phase A

Phase angle of phase A of the three-phase voltage source connected to the A,B,C terminals of the drive (deg). This parameter is not used when using the detailed rectifier.

Four-Quadrant Three-Phase Rectifier DC Drive

Controller Tab

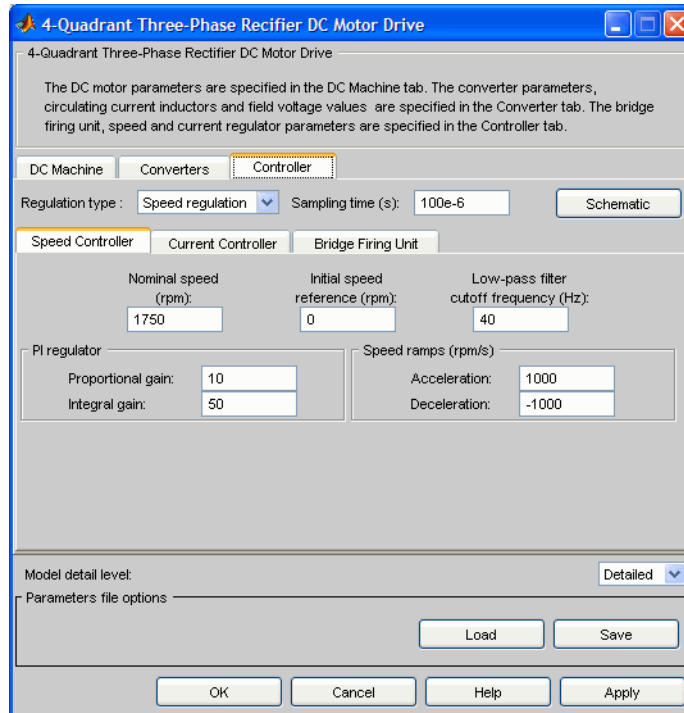

Schematic Button

When you press this button, a diagram illustrating the speed and current controllers schematics appears.

Regulation Type

This pop-up menu allows you to choose between speed and torque regulation.

Sampling Time

The controller (speed and current) sampling time (s). The sampling time has to be a multiple of the simulation time step.

Four-Quadrant Three-Phase Rectifier DC Drive

Controller — Speed Controller Subtab

Nominal Speed

The nominal speed value of the DC motor (rpm). This value is used to convert motor speed from rpm to p.u. (per unit).

Initial Speed Reference

The initial speed reference value (rpm). This value allows the user to start a simulation with a speed reference other than 0 rpm.

Low-Pass Filter Cutoff Frequency

Cutoff frequency of the low-pass filter used to filter the motor speed measurement (Hz).

Proportional Gain

The proportional gain of the PI speed controller.

Integral Gain

The integral gain of the PI speed controller.

Acceleration

The maximum change of speed allowed during motor acceleration (rpm/s). Too great a value can cause armature over-current.

Deceleration

The maximum change of speed allowed during motor deceleration (rpm/s). Too great a value can cause armature over-current.

Four-Quadrant Three-Phase Rectifier DC Drive

Controller — Current Controller Subtab

4-Quadrant Three-Phase Rectifier DC Motor Drive

The DC motor parameters are specified in the DC Machine tab. The converter parameters, circulating current inductors and field voltage values are specified in the Converter tab. The bridge firing unit, speed and current regulator parameters are specified in the Controller tab.

DC Machine Converters **Controller**

Regulation type: Speed regulation Sampling time (s): 100e-6 Schematic

Speed Controller **Current Controller** Bridge Firing Unit

Low-pass filter cutoff frequency (Hz): 120 Symmetrical reference limit (p.u.): 1.5

Nominal values

Power (W):	5746	Proportional gain:	1.1
Voltage (V):	240	Integral gain:	90

PI regulator

Model detail level: Detailed

Parameters file options

Load Save

OK Cancel Help Apply

Power and Voltage nominal values

The DC motor nominal power (VA) and voltage (V) values. The nominal power and voltage values are used to convert armature current from amperes to p.u. (per unit).

Proportional Gain

The proportional gain of the PI current controller.

Integral Gain

The integral gain of the PI current controller.

Low-Pass Filter Cutoff Frequency

Cutoff frequency of the low-pass filter used to filter the armature current measurement (Hz).

Four-Quadrant Three-Phase Rectifier DC Drive

Symmetrical Reference Limit

Symmetrical current reference (p.u.) limit around 0 p.u. 1.5 p.u. is a common value.

Controller – Bridge Firing Unit Subtab

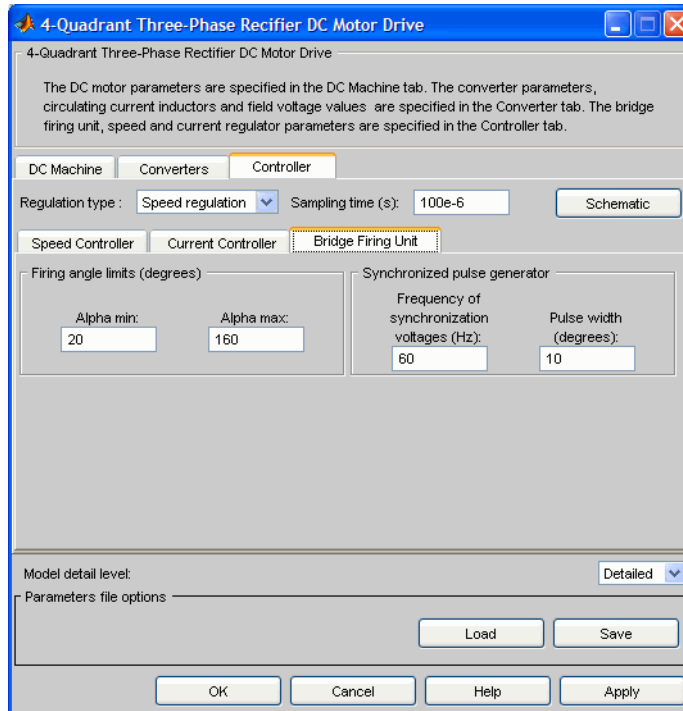

Alpha Min

Minimum firing angle value (deg.). 20 degrees is a common value.

Alpha Max

Maximum firing angle value (deg.). 160 degrees is a common value.

Frequency of Synchronization Voltages

Frequency of the synchronization voltages used by the discrete synchronized 6-pulse generator block (Hz). This frequency is equal to the

Four-Quadrant Three-Phase Rectifier DC Drive

line frequency of the three-phase power line. This parameter is not used when using the average-value converter.

Pulse Width

The width of the pulses applied to the thyristor gates (deg.). This parameter is not used when using the average-value converter.

Block Inputs and Outputs

SP

The speed or torque set point. Note that the speed set point can be a step function, but the speed change rate will follow the acceleration / deceleration ramps.

Mec_T

The mechanical load torque input. If the load torque and the speed have opposite signs, the accelerating torque will be the sum of the electromagnetic and load torques.

A, B, C

The three-phase electric connections. The voltage must be adequate for the motor size.

Motor

The motor measurement vector. This vector is composed of two elements:

- The armature voltage
- The DC motor measurement vector (containing the speed, armature current, field current, and electromagnetic torque values). Note that the speed signal is converted from rad/s to rpm before output.

Conv

the three-phase converter measurement vector. It includes:

- The output voltage of converter 1
- The output voltage of converter 2
- The output current of converter 1
- The output current of converter 2

Note that all current and voltage values of the detailed bridges can be visualized with the Multimeter block.

Ctrl

The controller measurement vector. This vector contains:

Four-Quadrant Three-Phase Rectifier DC Drive

- The armature current reference
- The firing angle computed by the current controller
- The speed or torque error (difference between the speed reference ramp and actual speed or between the torque reference and actual torque)
- The speed reference ramp or torque reference

Model Specifications

The library contains a 5 hp and a 200 hp drive parameter set. The specifications of these two drives are shown in the following table.

5 HP and 200 HP Drive Specifications

		5 HP Drive	200 HP Drive
Drive Input Voltage			
	Amplitude	230 V	380 V
	Frequency	60 Hz	50 Hz
Motor Nominal Values			
	Power	5 hp	200 hp
	Speed	1750 rpm	1184 rpm
	Voltage	240 V	440 V

Example

The `dc4_example` demo illustrates the three-phase dual-converter drive used with the 200 hp drive parameter set during torque regulation. A 5 hp parameter set is also available in the library.

The converters are fed by a 380 V AC 50 Hz voltage source.

Four-Quadrant Three-Phase Rectifier DC Drive

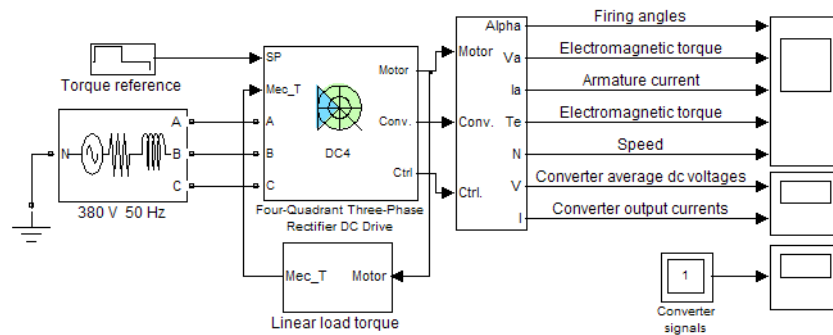

Discrete,
Ts = 5e-006 s.

Four-Quadrant Three-Phase Rectifier 200 HP DC Drive
with circulating current

More Info

The motor is coupled to a linear load, which means that the mechanical torque of the load is proportional to the speed.

The initial torque reference is set to 0 N.m and the armature current is null. No electromagnetic torque is produced and the motor stays still.

At $t = 0.2$ s, the torque reference jumps to 600 N.m. This causes the armature current to rise to about 180 A. The armature current is supplied by converter 1, and the total current in this converter is the sum of load current and circulating current. Converter 2 simply carries the circulating current. Notice that the armature current follows the reference current quite accurately, with fast response time and small overshooting. Observe also that the firing angles are symmetrical around 90 degrees and that the converter average output DC voltages are equal but of opposite signs.

The electromagnetic torque produced by the armature current flow causes the motor to accelerate. The speed rises and starts to stabilize around $t = 4$ s at about 560 rpm, the sum of the load and viscous friction torques beginning to equalize the electromagnetic torque.

At $t = 4$ s, the torque reference is set to 0 N.m and the load torque causes the motor to decelerate. Notice that the four reactors keep the current oscillations quite small.

Four-Quadrant Three-Phase Rectifier DC Drive

At $t = 8$ s, the torque reference is set to -300 N.m. The armature current jumps down to -90 A and is now delivered by converter 2 while converter 1 only handles the circulating current. Converter 2 is now working in rectifier mode and converter 1 in inverter mode.

The negative electromagnetic torque produced allows the motor to accelerate in the negative speed plane.

At $t = 12$ s, speed starts to stabilize around -290 rpm.

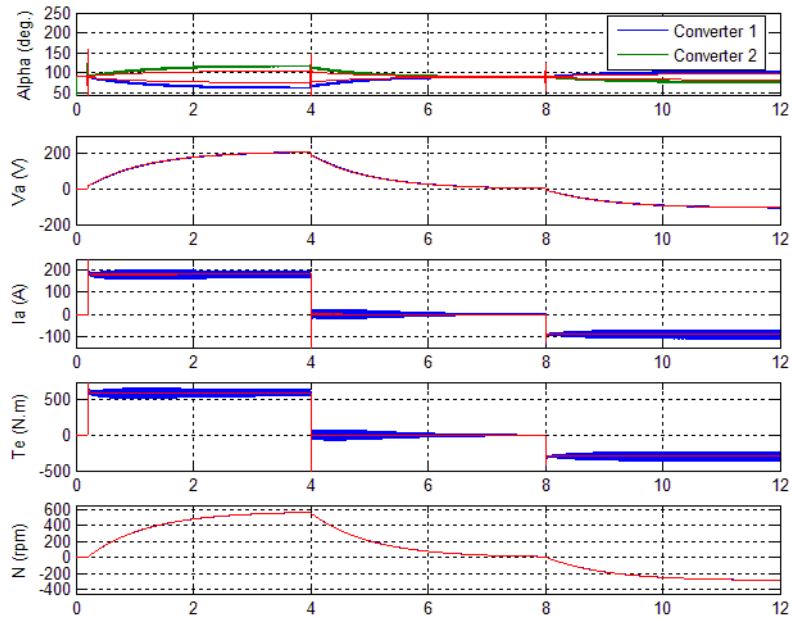

Four-Quadrant Three-Phase Rectifier DC Drive

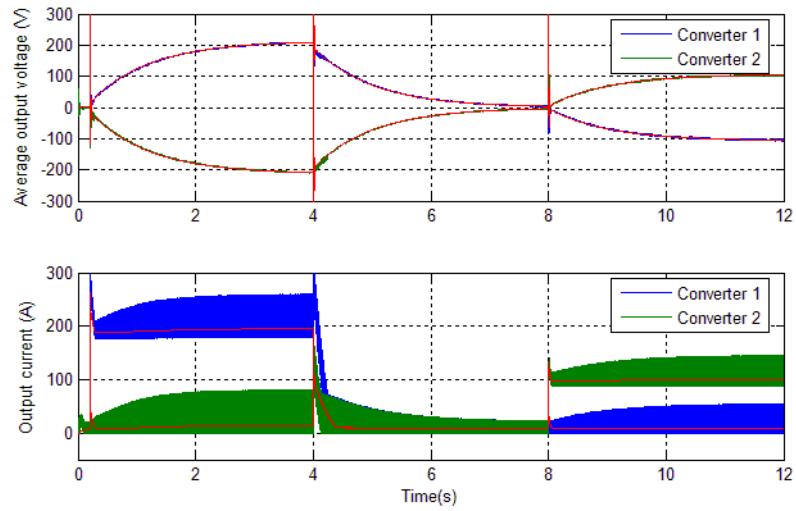

References

- [1] Sen, P.C., *Thyristor DC Drives*, J.Wiley and Sons, 1981

Generic Power System Stabilizer

Purpose Implement a generic power system stabilizer for the synchronous machine

Library Machines

Description



The Generic Power System Stabilizer (PSS) block can be used to add damping to the rotor oscillations of the synchronous machine by controlling its excitation. The disturbances occurring in a power system induce electromechanical oscillations of the electrical generators. These oscillations, also called power swings, must be effectively damped to maintain the system stability. The output signal of the PSS is used as an additional input (*vstab*) to the Excitation System block. The PSS input signal can be either the machine speed deviation, *dw*, or its acceleration power, $P_a = P_m - P_e$ (difference between the mechanical power and the electrical power).

The Generic Power System Stabilizer is modeled by the following nonlinear system:

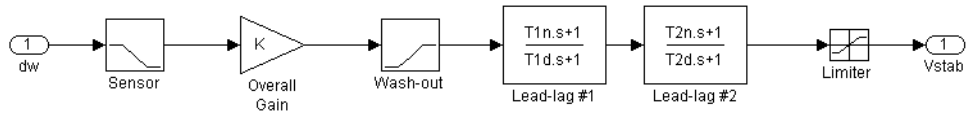

To ensure a robust damping, the PSS should provide a moderate phase advance at frequencies of interest in order to compensate for the inherent lag between the field excitation and the electrical torque induced by the PSS action.

The model consists of a low-pass filter, a general gain, a washout high-pass filter, a phase-compensation system, and an output limiter. The general gain *K* determines the amount of damping produced by the stabilizer. The washout high-pass filter eliminates low frequencies that are present in the *dw* signal and allows the PSS to respond only to speed changes. The phase-compensation system is represented by a cascade of two first-order lead-lag transfer functions used to compensate the phase lag between the excitation voltage and the electrical torque of the synchronous machine.

Generic Power System Stabilizer

Dialog Box and Parameters

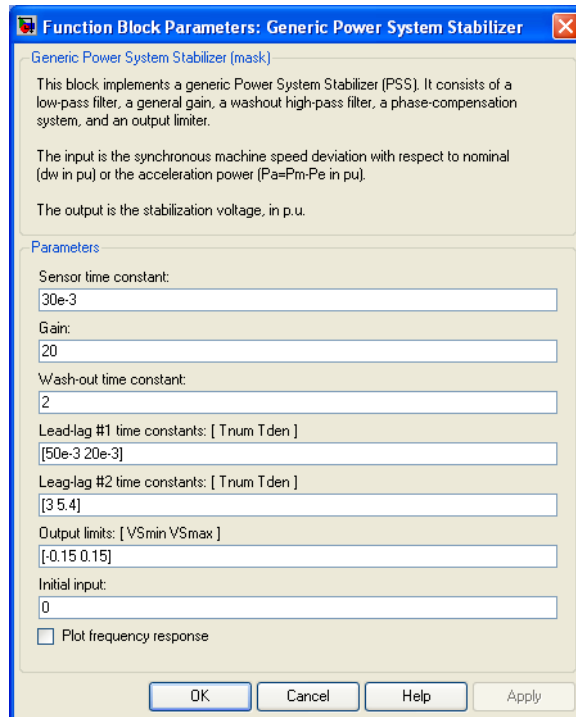

Sensor time constant

The time constant, in seconds (s), of the first-order low-pass filter used to filter the block's input signal.

Gain

The overall gain K of the generic power system stabilizer.

Wash-out time constant

The time constant, in seconds (s), of the first-order high-pass filter used by the washout system of the model.

Lead-lag #1 time constants: [Tnum Tden]

The numerator time constant T_{1n} and denominator time constant T_{1d} , in seconds (s), of the first lead-lag transfer function.

Lead-lag #2 time constants: [Tnum Tden]

The numerator time constant T2n and denominator time constant T2d, in seconds (s), of the second lead-lag transfer function.

Output limits: [Vsmin Vsmax]

The limits VSmin and VSmax, in p.u., imposed on the output of the stabilizer.

Initial input

The initial DC voltage, in p.u., of the block's input signal. Specification of this parameter is required to initialize all states and start the simulation in steady state with vstab set to zero.

Plot frequency response

If selected, a plot of the frequency response of the stabilizer is displayed when you click the **Apply** button.

Magnitude in dB

The **Magnitude in dB** parameter is not visible if the **Plot frequency response** is not selected. If selected, the magnitude of the frequency response is plotted in dB.

Frequency range

The **Frequency range** parameter is not visible in the dialog box if the **Plot frequency response** is not selected. Specify the frequency range used to plot the frequency response of the stabilizer.

Inputs and Outputs

In

Two types of signals can be used at the input In:

- The synchronous machine speed deviation dw signal (in p.u.)
- The synchronous machine acceleration power $P_a = P_m - P_{e0}$ (difference between the machine mechanical power and output electrical power (in p.u.))

Vstab

The output is the stabilization voltage (in p.u.) to connect to the Vstab input of the Excitation System block used to control the terminal voltage of the synchronous machine.

Example

See the help text of the power_PSS demo model.

Generic Power System Stabilizer

References Kundur, P., *Power System Stability and Control*, McGraw-Hill, 1994, Section 12.5.

See Also Multiband Power System Stabilizer

Purpose Provide a connection to the ground

Library Elements

Description The Ground block implements a connection to the ground.



Example The power_ground demo shows an application of the Ground block.

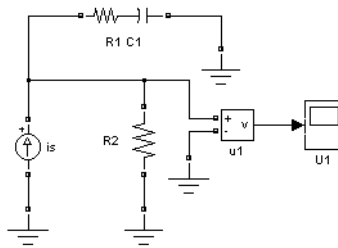

See Also Neutral

GTO

Purpose

Implement a gate turn off (GTO) thyristor model

Library

Power Electronics

Description

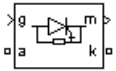

The gate turnoff (GTO) thyristor is a semiconductor device that can be turned on and off via a gate signal. Like a conventional thyristor, the GTO thyristor can be turned on by a positive gate signal ($g > 0$). However, unlike the thyristor, which can be turned off only at a zero crossing of current, the GTO can be turned off at any time by the application of a gate signal equal to 0.

The GTO thyristor is simulated as a resistor R_{on} , an inductor L_{on} , and a DC voltage source V_f connected in series with a switch. The switch is controlled by a logical signal depending on the voltage V_{ak} , the current I_{ak} , and the gate signal g .

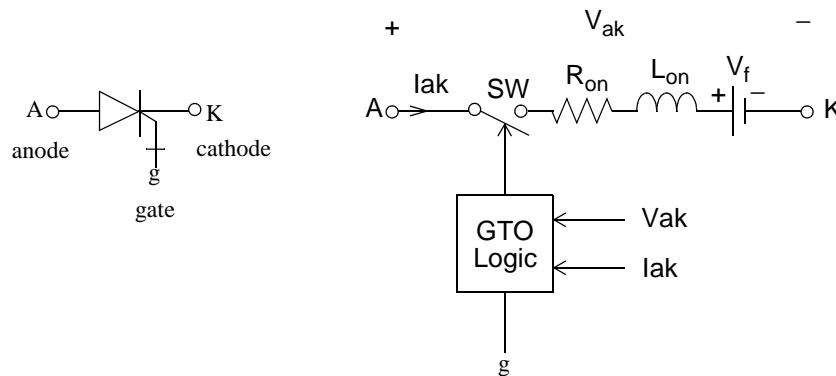

The V_f , R_{on} , and L_{on} parameters are the forward voltage drop while in conduction, the forward conducting resistance, and the inductance of the device. The GTO block also contains a series R_s - C_s snubber circuit that can be connected in parallel with the GTO device (between terminal ports A and K).

The GTO thyristor turns on when the anode-cathode voltage is greater than V_f and a positive pulse signal is present at the gate input ($g > 0$). When the gate signal is set to 0, the GTO thyristor starts to block but its current does not stop instantaneously.

Because the current extinction process of a GTO thyristor contributes significantly to the turnoff losses, the turnoff characteristic is built into the

model. The current decrease is approximated by two segments. When the gate signal becomes 0, the current I_{ak} first decreases from the value I_{max} (value of I_{ak} when the GTO thyristor starts to open) to $I_{max}/10$, during the fall time (T_f), and then from $I_{max}/10$ to 0 during the tail time (T_t). The GTO thyristor turns off when the current I_{ak} becomes 0. The latching and holding currents are not considered.

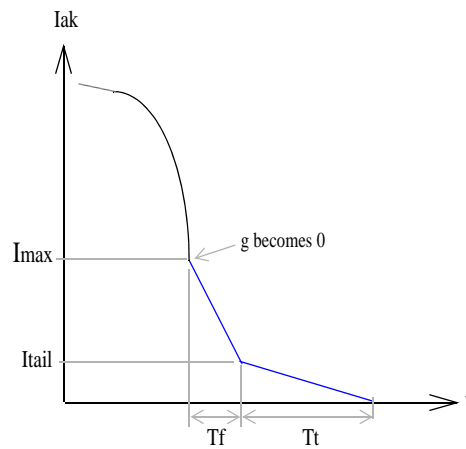

Dialog Box and Parameters

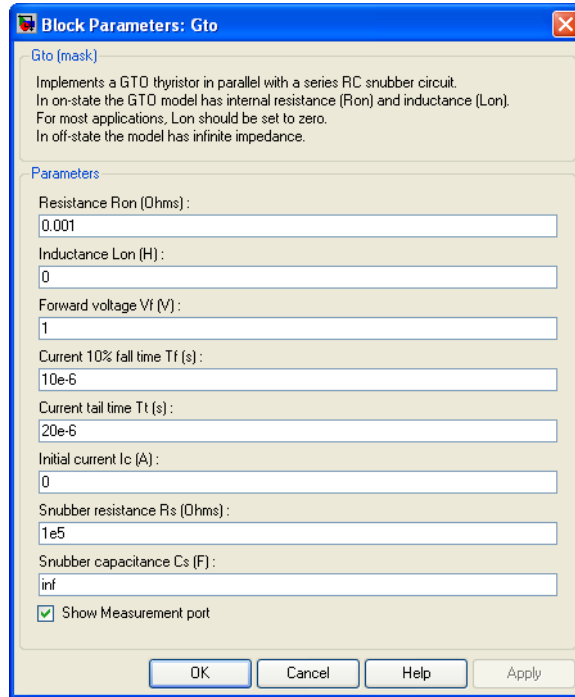

Resistance Ron

The internal resistance Ron, in ohms (Ω).

Inductance Lon

The internal inductance Lon, in henries (H). The **Inductance Lon** parameter cannot be set to 0.

Forward voltage Vf

The forward voltage of the GTO thyristor device, in volts (V).

Current 10% fall time

The current fall time Tf, in seconds (s).

Current tail time

The current tail time Tt, in seconds (s).

Initial current I_c

You can specify an initial current flowing in the GTO thyristor. It is usually set to 0 in order to start the simulation with the device blocked.

If the **Initial Current IC** parameter is set to a value greater than 0, the steady-state calculation of SimPowerSystems considers the initial status of the GTO as closed. Initializing all states of a power electronic converter is a complex task. Therefore, this option is useful only with simple circuits.

Snubber resistance R_s

The snubber resistance, in ohms (Ω). Set the **Snubber resistance R_s** parameter to `inf` to eliminate the snubber from the model.

Snubber capacitance C_s

The snubber capacitance, in farads (F). Set the **Snubber capacitance C_s** parameter to 0 to eliminate the snubber, or to `inf` to get a resistive snubber.

Show measurement port

If selected, add a Simulink output to the block returning the GTO current and voltage.

Inputs and Outputs

g

Simulink signal to control the gate of the GTO.

m

The Simulink output of the block is a vector containing two signals. You can demultiplex these signals by using the Bus Selector block provided in the Simulink library.

Signal	Definition	Units
1	GTO current	A
2	GTO voltage	V

Assumptions and Limitations

The GTO block implements a macro model of a real GTO thyristor. It does not take into account either the geometry of the device or the underlying physical processes of the device [1].

The GTO block requires a continuous application of the gate signal ($g > 0$) in order to be in the on state (with $I_{ak} > 0$). The latching current and the holding current are not considered. The critical value of the derivative of the reapplied anode-cathode voltage is not considered.

Depending on the value of the inductance L_{on} , the GTO is modeled either as a current source ($L_{on} > 0$) or as a variable topology circuit ($L_{on} = 0$). The GTO block cannot be connected in series with an inductor, a current source, or an open circuit, unless its snubber circuit is in use. See Chapter 3, “Improving Simulation Performance” for more details on this topic.

Use the Powergui block to specify either continuous simulation or discretization of your electrical circuit containing GTO blocks. When using a continuous model, the `ode23t` stiff solver with a relative tolerance of $1e-4$ is recommended for best accuracy and simulation speed.

The inductance L_{on} is forced to 0 if you choose to discretize your circuit.

Example

The `power_buckconv` demo illustrates the use of the GTO block in a buck converter topology. The basic polarized snubber circuit is connected across the GTO block. The snubber circuit consists of a capacitor C_s , a resistor R_s , and a diode D_s . The parasitic inductance L_s of the snubber circuit is also taken into consideration.

The parameters of the GTO block are those found in the dialog box section, except for the internal snubber, which is not used ($R_s = \text{inf}$; $C_s = 0$). The switching frequency is 1000 Hz and the pulse width is 216 degrees (duty cycle: 60%).

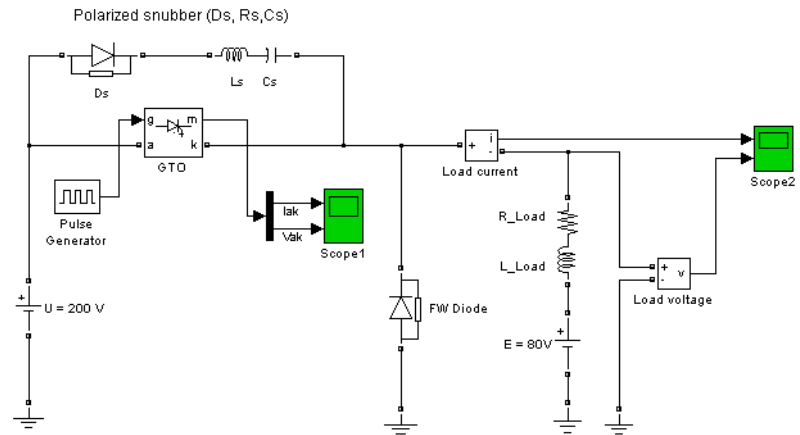

Run the simulation. Observe the GTO voltage and current as well as the load voltage and current.

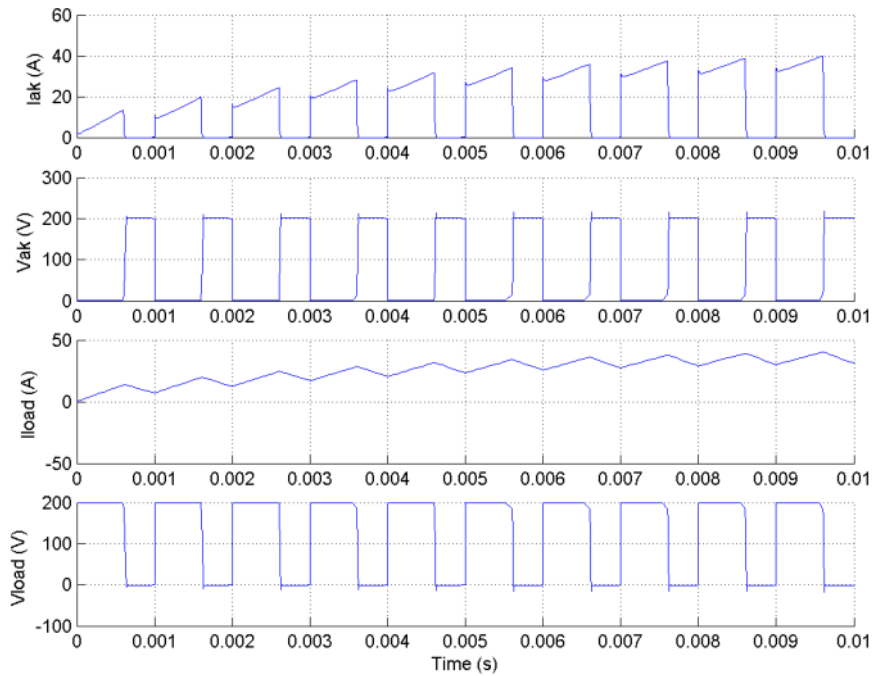

References

[1] Mohan, N., T.M. Undeland, and W.P. Robbins, *Power Electronics: Converters, Applications, and Design*, John Wiley & Sons, Inc., New York, 1995.

See Also

IGBT, MOSFET, Three-Level Bridge, Thyristor, Universal Bridge

Hydraulic Turbine and Governor

Purpose Model a hydraulic turbine and a proportional-integral-derivative (PID) governor system

Library Machines

Description The Hydraulic Turbine and Governor block implements a nonlinear hydraulic turbine model, a PID governor system, and a servomotor [1].

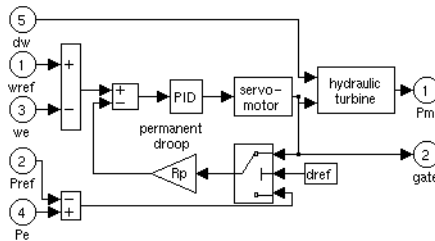
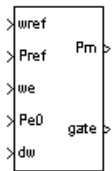

The hydraulic turbine is modeled by the following nonlinear system.

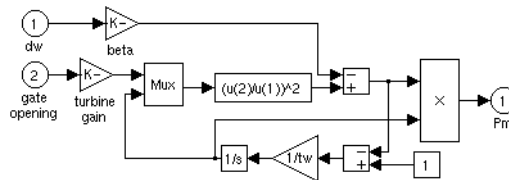

The gate servomotor is modeled by a second-order system.

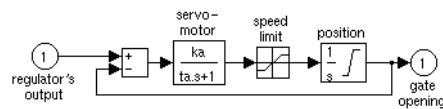

Hydraulic Turbine and Governor

Dialog Box and Parameters

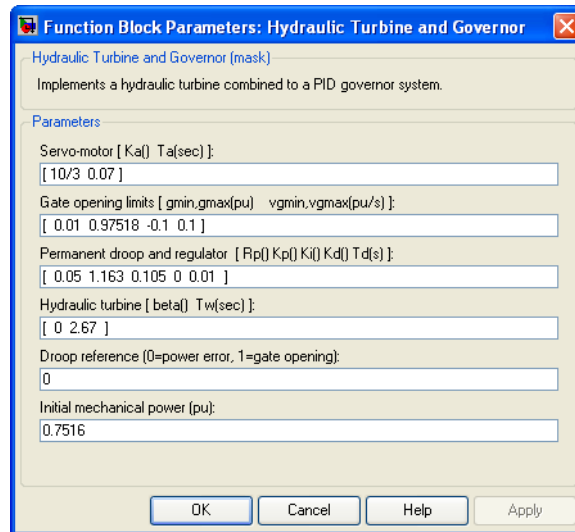

Servo-motor

The gain K_a and time constant T_a , in seconds (s), of the first-order system representing the servomotor.

Gate opening limits

The limits g_{min} and g_{max} (p.u.) imposed on the gate opening, and vg_{min} and vg_{max} (p.u./s) imposed on gate speed.

Permanent droop and regulator

The static gain of the governor is equal to the inverse of the permanent droop R_p in the feedback loop. The PID regulator has a proportional gain K_p , an integral gain K_i , and a derivative gain K_d . The high-frequency gain of the PID is limited by a first-order low-pass filter with time constant T_d (s).

Hydraulic turbine

The speed deviation damping coefficient β and water starting time T_w (s).

Droop reference

Specifies the input of the feedback loop: gate position (set to 1) or electrical power deviation (set to 0).

Initial mechanical power

The initial mechanical power P_{m0} (p.u.) at the machine's shaft. This value is automatically updated by the load flow utility of the Powergui block.

Inputs and Outputs

w_{ref}

Reference speed, in p.u.

P_{ref}

Reference mechanical power in p.u. This input can be left unconnected if you want to use the gate position as input to the feedback loop instead of the power deviation.

w_e

Machine actual speed, in p.u.

P_{e0}

Machine actual electrical power in p.u. This input can be left unconnected if you want to use the gate position as input to the feedback loop instead of the power deviation.

dw

Speed deviation, in p.u.

P_m

Mechanical power P_m for the Synchronous Machine block, in p.u.

$gate$

Gate opening, in p.u.

Example

This `power_turbine` demo illustrates the use of the Synchronous Machine associated with the Hydraulic Turbine and Governor (HTG) and Excitation System blocks. It also demonstrates the use of the load flow tool of the Powergui block to initialize machine currents and initial mechanical power of the HTG block. A three-phase generator rated 200 MVA, 13.8 kV, 112.5 rpm is connected to a 230 kV network through a Delta-Y 210 MVA transformer. The system starts in steady state with the generator supplying 150 MW of active power. At $t = 0.1$ s, a three-phase to ground fault occurs on the 230 kV bus of the transformer. The fault is cleared after six cycles ($t = 0.2$ s).

In order to start the simulation in steady state, you must initialize the Synchronous Machine block for the desired load flow. Open the Powergui and select **Load flow and machine initialization**. The machine **Bus type** should

Hydraulic Turbine and Governor

be already initialized as PV generator, indicating that the load flow is performed with the machine controlling the active power and its terminal voltage. Specify the desired values by entering the following parameters:

- Terminal voltage U_{AB} (V_{rms}) = 13800
- Active power (watts) = 150e6

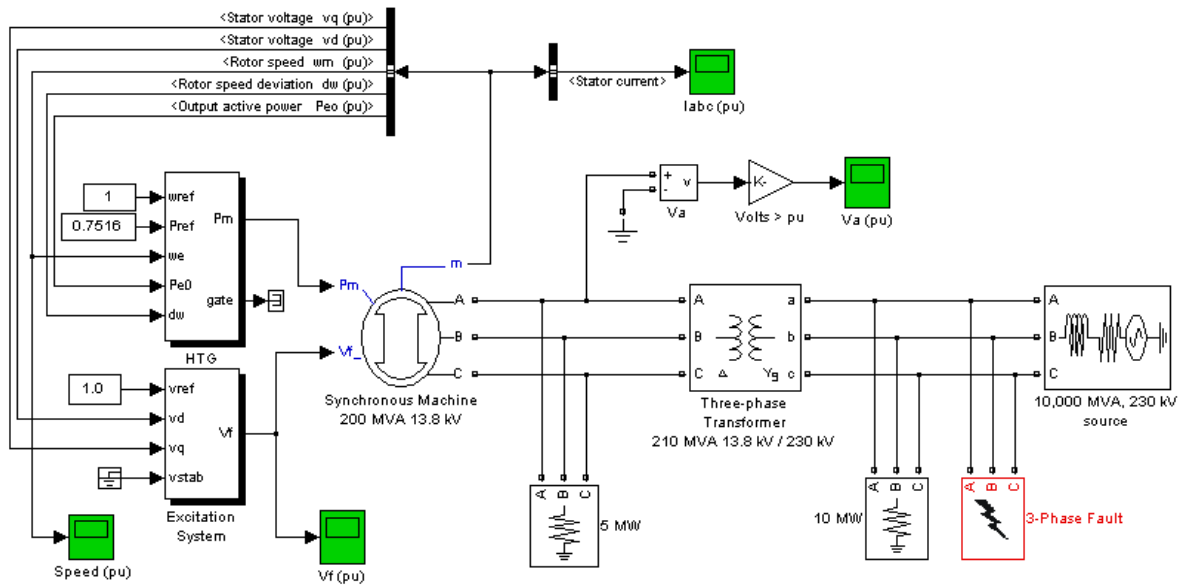

Then click the **Update Load Flow** button. Once the load flow has been solved, the line-to-line machine voltages as well as the phase currents flowing out of the machine. The machine reactive power, mechanical power, and field voltage requested to supply the electrical power should also be displayed:

- $Q = 3.4$ Mvar
- $P_{mec} = 150.32$ MW (0.7516 p.u.)
- Field voltage $V_f = 1.291$ p.u.

The load flow also initializes the HTG and Excitation System blocks. Open the HTG block menu and notice that the initial mechanical power is set to 0.5007

Hydraulic Turbine and Governor

p.u. (100.14 MW). Then open the Excitation System block menu and note that the initial terminal voltage and field voltage are set respectively to 1.0 and 1.291 p.u. Open the four scopes and start the simulation. The simulation starts in steady state.

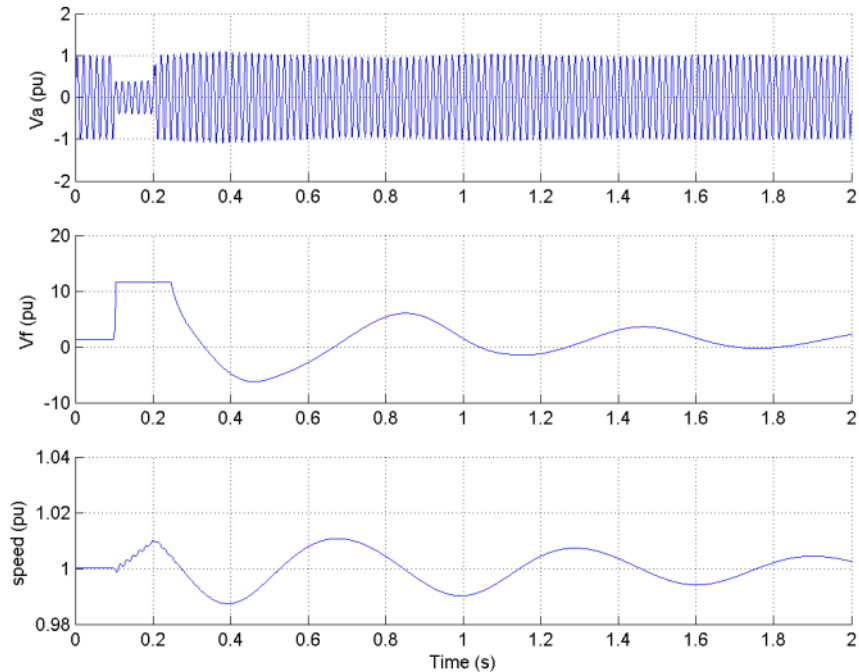

Observe that the terminal voltage V_a is 1.0 p.u. at the beginning of the simulation. It falls to about 0.4 p.u. during the fault and returns to nominal quickly after the fault is cleared. This quick response in terminal voltage is due to the fact that the Excitation System output V_f can go as high as 11.5 p.u., which it does during the fault. The speed of the machine increases to 1.01 p.u. during the fault, then it oscillates around 1 p.u. as the governor system regulates it. The speed takes much longer than the terminal voltage to stabilize, mainly because the rate of valve opening/closing in the governor system is limited to 0.1 p.u./s.

Hydraulic Turbine and Governor

References

[1] IEEE Working Group on Prime Mover and Energy Supply Models for System Dynamic Performance Studies, "Hydraulic Turbine and Turbine Control Models for Dynamic Studies," *IEEE Transactions on Power Systems*, Vol. 7, No. 1, February, 1992, pp. 167-179.

See Also

Excitation System, Steam Turbine and Governor, Synchronous Machine

Purpose Implement an ideal switch device

Library Power Electronics

Description

The Ideal Switch block does not correspond to a particular physical device. When used with appropriate switching logic, it can be used to model simplified semiconductor devices such as a GTO or a MOSFET, or even a power circuit breaker with current chopping. The switch is simulated as a resistor R_{on} in series with a switch controlled by a logical gate signal g .

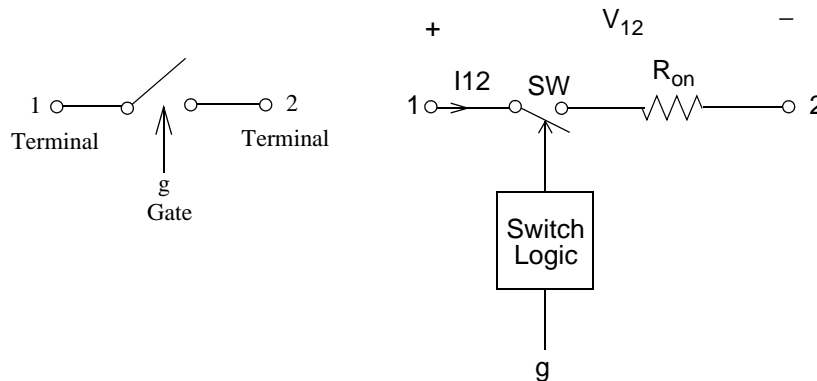
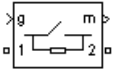

The Ideal Switch block is fully controlled by the gate signal ($g > 0$ or $g = 0$). It has the following characteristics:

- Blocks any forward or reverse applied voltage with 0 current flow when $g = 0$
- Conducts any bidirectional current with quasi-zero voltage drop when $g > 0$
- Switches instantaneously between on and off states when triggered

The Ideal Switch block turns on when a positive signal is present at the gate input ($g > 0$). It turns off when the gate signal equals 0 ($g = 0$).

The Ideal Switch block also contains a series R_s - C_s snubber circuit that can be connected in parallel with the ideal switch (between nodes 1 and 2).

Ideal Switch

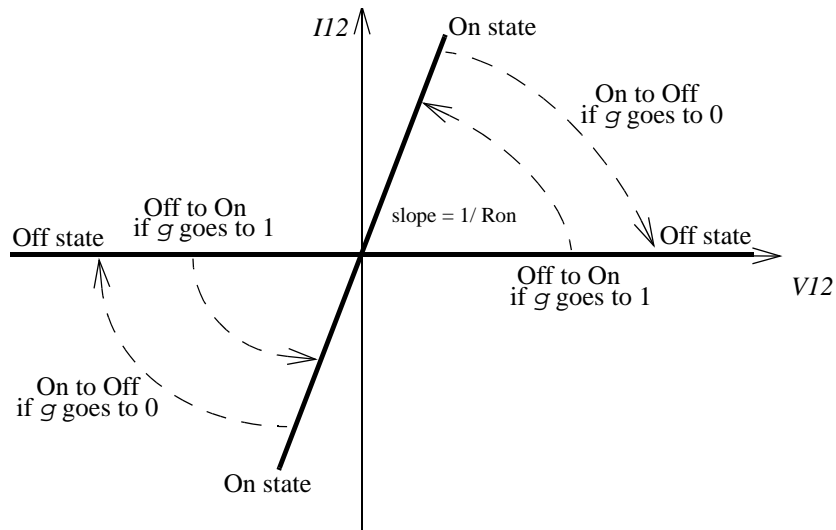

Dialog Box and Parameters

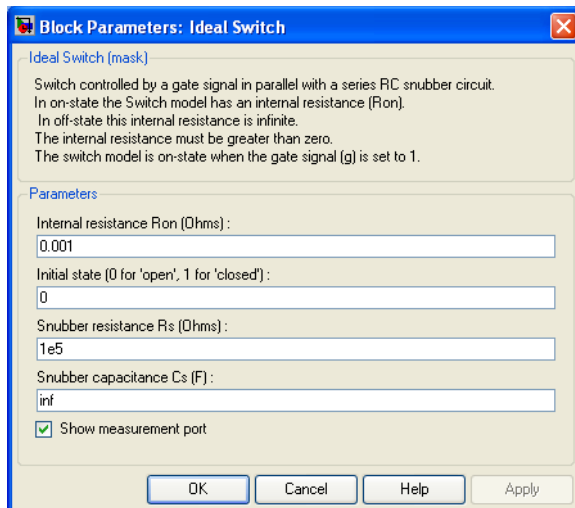

Internal resistance R_{on}

The internal resistance of the switch device, in ohms (Ω). The **Internal resistance R_{on}** parameter cannot be set to 0.

Initial state

The initial state of the Ideal Switch block. The initial status of the Ideal Switch block is taken into account in the steady-state calculation of SimPowerSystems.

Snubber resistance R_s

The snubber resistance, in ohms (Ω). Set the **Snubber resistance R_s** parameter to `inf` to eliminate the snubber from the model.

Snubber capacitance C_s

The snubber capacitance in farads (F). Set the **Snubber capacitance C_s** parameter to 0 to eliminate the snubber, or to `inf` to get a resistive snubber.

Show measurement port

If selected, add a Simulink output to the block returning the ideal switch current and voltage.

Inputs and Outputs

g

Simulink signal to control the opening and closing of the switch.

m

The Simulink output of the block is a vector containing two signals. You can demultiplex these signals by using the Bus Selector block provided in the Simulink library.

Signal	Definition	Units
1	Ideal switch current	A
2	Ideal switch voltage	V

Assumptions and Limitations

The Ideal Switch block is modeled as a current source. It cannot be connected in series with an inductor, a current source, or an open circuit, unless its snubber circuit is in use. See Chapter 3, “Improving Simulation Performance” for more details on this topic.

Use the Powergui block to specify either continuous simulation or discretization of your electrical circuit containing ideal switches. When using a

Ideal Switch

continuous model, the ode23t stiff solver with a relative tolerance of $1e-4$ is recommended for best accuracy and simulation speed.

Example

The power_switch demo uses the Ideal Switch block to switch an RLC circuit on an AC source (60 Hz). The switch, which is initially closed, is first opened at $t = 50$ ms (3 cycles) and then reclosed at $t = 138$ ms (8.25 cycles). The Ideal Switch block has 0.01 ohms resistance and no snubber is used.

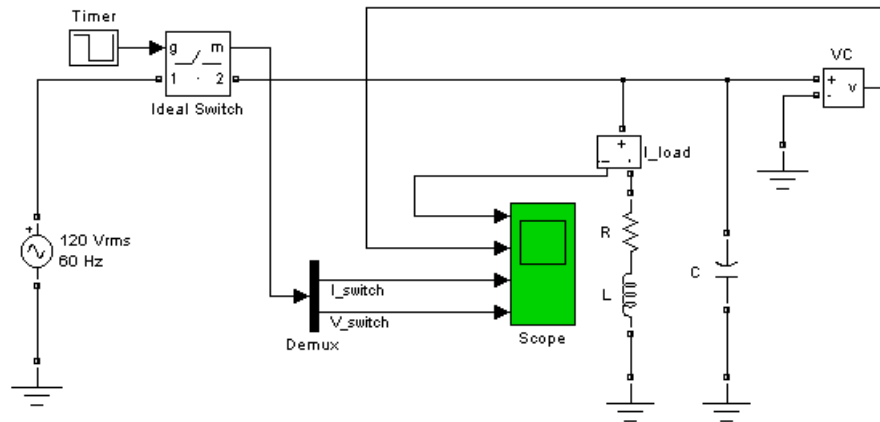

Run the simulation and observe the inductor current, the switch current, and the capacitor voltage. Notice the high-frequency overvoltage produced by inductive current chopping. Note also the high switch current spike when the switch is reclosed on the capacitor at maximum source voltage.

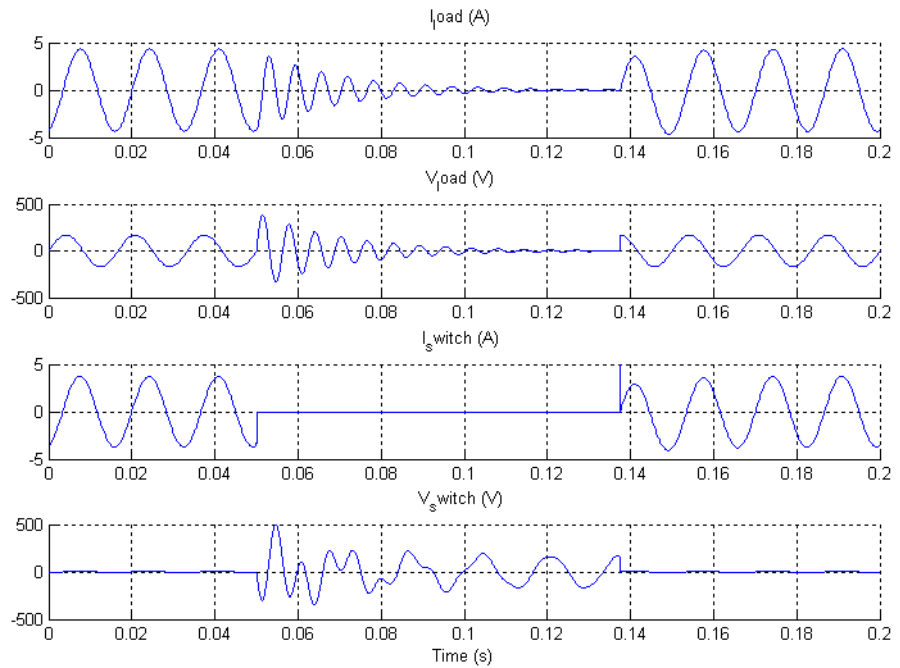

References

Mohan, N., T.M. Undeland, and W.P. Robbins, *Power Electronics: Converters, Applications, and Design*, John Wiley & Sons, Inc., New York, 1995.

See Also

Breaker

IGBT

Purpose

Implement an insulated gate bipolar transistor (IGBT)

Library

Power Electronics

Description

The IGBT block implements a semiconductor device controllable by the gate signal. The IGBT is simulated as a series combination of a resistor R_{on} , inductor L_{on} , and a DC voltage source V_f in series with a switch controlled by a logical signal ($g > 0$ or $g = 0$)

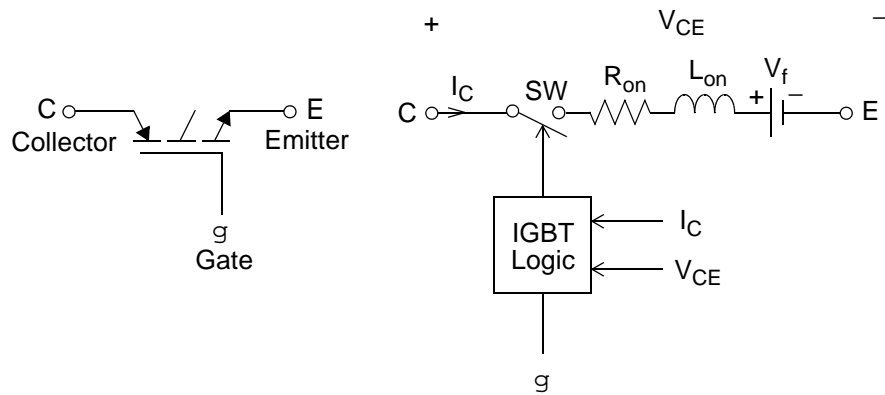

The IGBT turns on when the collector-emitter voltage is positive and greater than V_f and a positive signal is applied at the gate input ($g > 0$). It turns off when the collector-emitter voltage is positive and a 0 signal is applied at the gate input ($g = 0$).

The IGBT device is in the off state when the collector-emitter voltage is negative. Note that many commercial IGBTs do not have the reverse blocking capability. Therefore, they are usually used with an antiparallel diode.

The IGBT block contains a series R_s - C_s snubber circuit, which is connected in parallel with the IGBT device (between terminals C and E).

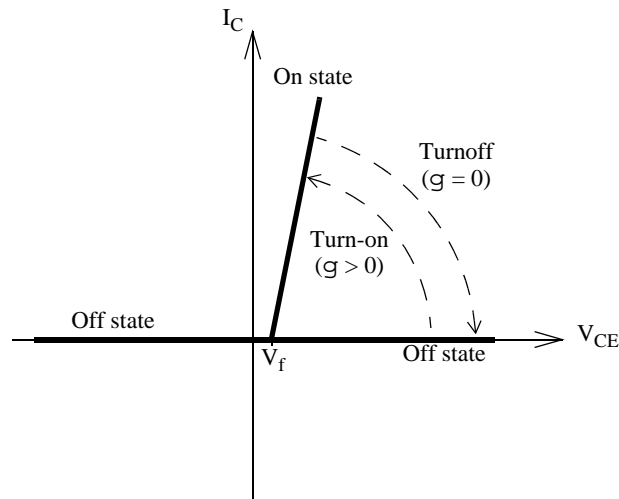

The turnoff characteristic of the IGBT model is approximated by two segments. When the gate signal falls to 0, the collector current decreases from I_{max} to $0.1 I_{max}$ during the fall time (T_f), and then from $0.1 I_{max}$ to 0 during the tail time (T_t).

IGBT

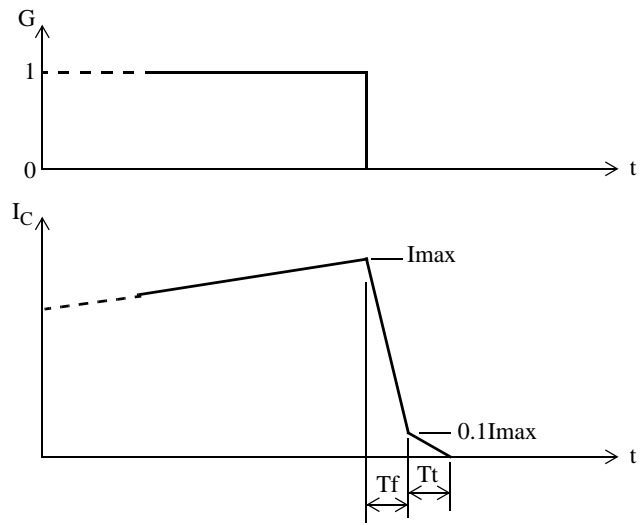

Dialog Box and Parameters

Block Parameters: IGBT

IGBT (mask)

Implements an IGBT device in parallel with a series RC snubber circuit.
 In on-state the IGBT model has internal resistance (Ron) and inductance (Lon).
 For most applications, Lon should be set to zero.
 In off-state the IGBT model has infinite impedance.

Parameters

Resistance Ron (Ohms):
0.001

Inductance Lon (H):
0

Forward voltage Vf (V):
1

Current 10% fall time Tf (s):
1e-6

Current tail time Tt (s):
2e-6

Initial current Ic (A):
0

Snubber resistance Rs (Ohms):
1e5

Snubber capacitance Cs (F):
inf

Show measurement port

OK Cancel Help Apply

Resistance Ron

The internal resistance Ron, in ohms (Ω).

Inductance Lon

The internal inductance Lon, in henries (H). The **Inductance Lon** parameter cannot be set to 0.

Forward voltage Vf

The forward voltage of the IGBT device, in volts (V).

Current 10% fall time

The current fall time Tf, in seconds (s).

Current tail time

The current tail time Tt, in seconds (s).

Initial current I_c

You can specify an initial current flowing in the IGBT. It is usually set to 0 in order to start the simulation with the device blocked.

If the **Initial Current IC** parameter is set to a value greater than 0, the steady-state calculation of SimPowerSystems considers the initial status of the IGBT as closed. Initializing all states of a power electronic converter is a complex task. Therefore, this option is useful only with simple circuits.

Snubber resistance R_s

The snubber resistance, in ohms (Ω). Set the **Snubber resistance R_s** parameter to `inf` to eliminate the snubber from the model.

Snubber capacitance C_s

The snubber capacitance in farads (F). Set the **Snubber capacitance C_s** parameter to 0 to eliminate the snubber, or to `inf` to get a resistive snubber.

Show measurement port

If selected, add a Simulink output to the block returning the diode IGBT current and voltage.

Inputs and Outputs

g

Simulink signal to control the opening and closing of the IGBT.

m

The Simulink output of the block is a vector containing two signals. You can demultiplex these signals by using the Bus Selector block provided in the Simulink library.

Signal	Definition	Units
1	IGBT current	A
2	IGBT voltage	V

Assumptions and Limitations

The IGBT block implements a macro model of the real IGBT device. It does not take into account either the geometry of the device or the complex physical processes [1].

Depending on the value of the inductance L_{on} , the IGBT is modeled either as a current source ($L_{on} > 0$) or as a variable topology circuit ($L_{on} = 0$). The IGBT block cannot be connected in series with an inductor, a current source, or an open circuit, unless its snubber circuit is in use. See Chapter 3, “Improving Simulation Performance” for more details on this topic.

Use the Powergui block to specify either continuous simulation or discretization of your electrical circuit containing IGBT blocks. When using a continuous model, the ode23t stiff solver with a relative tolerance of $1e-4$ is recommended for best accuracy and simulation speed.

The inductance L_{on} is forced to 0 if you choose to discretize your circuit.

Example

The `power_igbtconv` demo illustrates the use of the IGBT block in a boost DC-DC converter. The IGBT is switched on and off at a frequency of 10 kHz to transfer energy from the DC source to the load (RC). The average output voltage (V_R) is a function of the duty cycle (α) of the IGBT switch:

$$V_R = \frac{1}{1 - \alpha} V_{dc}$$

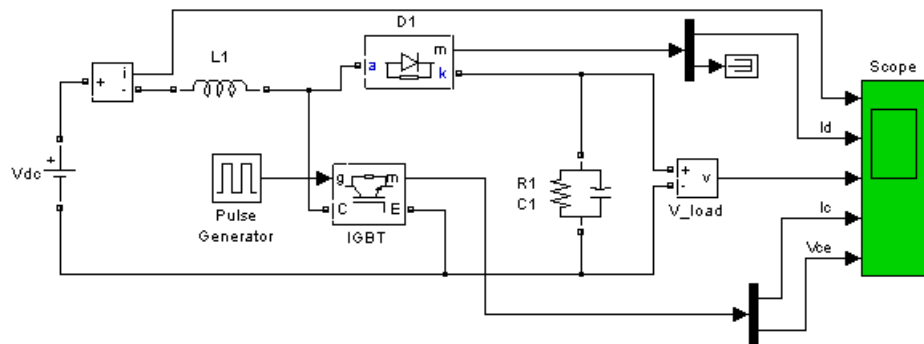

In our example, $\alpha = 0.5$ so that the theoretical value of V_R is 200 V, assuming no voltage drop across the diode and the IGBT.

Run the simulation and observe the inductor current (I_L), the IGBT collector current (I_C), the diode current (I_D), the IGBT device collector-emitter voltage (V_{CE}), and the load voltage (V_R).

The load voltage (197 V) is slightly lower than the theoretical value (200 V) mainly because of the forward voltage (V_f) of the diode (0.8 V) and of the IGBT ($V_f = 1$ V).

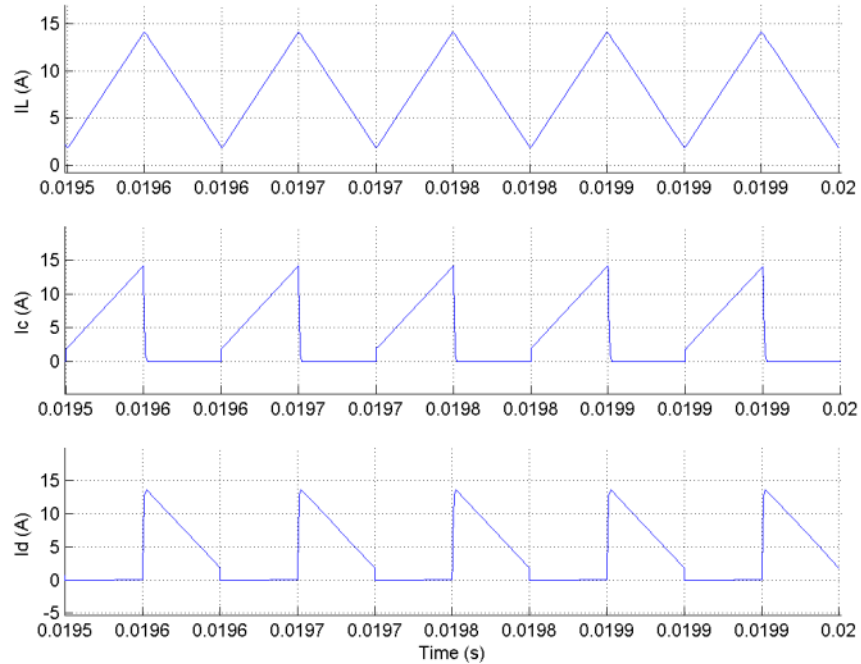

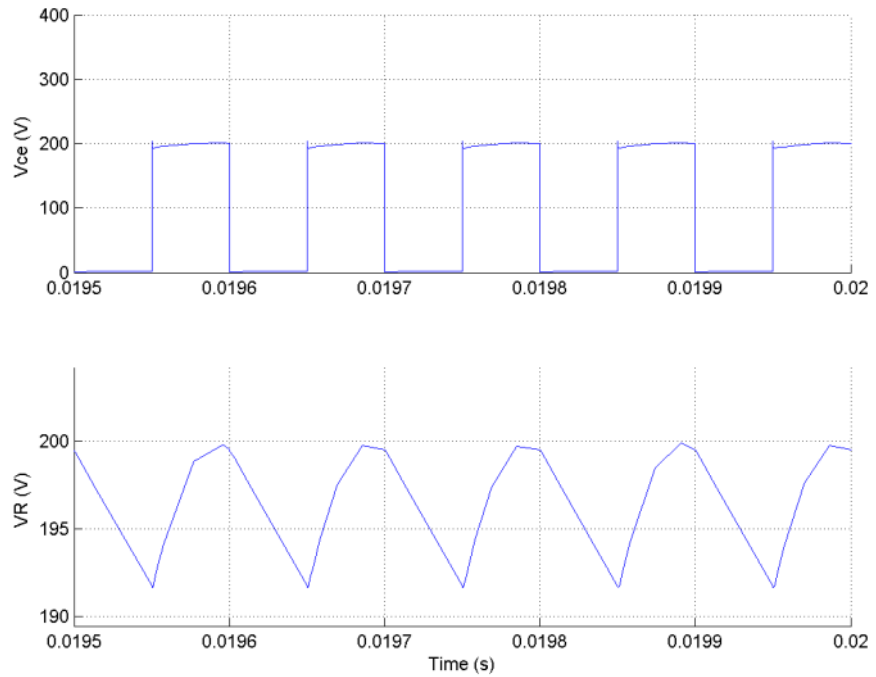

References

[1] Mohan, N., T.M. Undeland, and W.P. Robbins, *Power Electronics: Converters, Applications, and Design*, John Wiley & Sons, Inc., New York, 1995.

See Also

GTO, MOSFET, Three-Level Bridge, Thyristor

IGBT/Diode

Purpose Implements an ideal IGBT, GTO, or Mosfet and antiparallel diode

Library Power Electronics

Description The IGBT/Diode block is a simplified mode of an IGBT (or GTO or MOSFET)/Diode pair where the forward voltages of the forced-commutated device and diode are ignored.

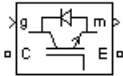

Dialog Box and Parameters

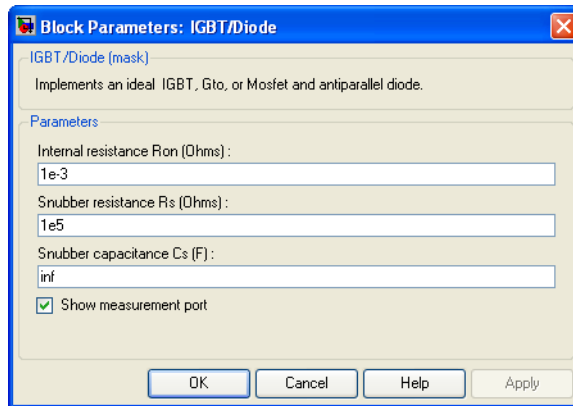

Internal resistance R_{on}

The internal resistance R_{on} of the IGBT device, in ohms (Ω).

Snubber resistance R_s

The snubber resistance, in ohms (Ω). Set the **Snubber resistance R_s** parameter to `inf` to eliminate the snubber from the model.

Snubber capacitance C_s

The snubber capacitance in farads (F). Set the **Snubber capacitance C_s** parameter to 0 to eliminate the snubber, or to `inf` to get a resistive snubber.

Show measurement port

If selected, add a Simulink output to the block returning the diode IGBT current and voltage.

Inputs and Outputs

g Simulink signal to control the opening and closing of the IGBT.

m The Simulink output of the block is a vector containing two signals. You can demultiplex these signals by using the Bus Selector block provided in the Simulink library.

Signal	Definition	Units
1	IGBT/Diode current	A
2	IGBT/diode voltage	V

Assumptions and Limitations

The IGBT/Diode block implements a macro model of the real IGBT and Diode devices. It does not take into account either the geometry of the devices or the complex physical processes [1].

The IGBT/Diode block cannot be connected in series with an inductor, a current source, or an open circuit, unless its snubber circuit is in use. See Chapter 3, “Improving Simulation Performance” for more details on this topic.

Use the Powergui block to specify either continuous simulation or discretization of your electrical circuit containing IGBT/Diode blocks. When using a continuous model, the ode23t stiff solver with a relative tolerance of 1e-4 is recommended for best accuracy and simulation speed.

Example

The power_1phPWM_IGBT demo illustrates use of the IGBT/Diode block in voltage-sourced converters. The system consists of two independent circuits illustrating single-phase PWM voltage-sourced converters (VSC):

- 1 Half-bridge converter
- 2 Full-bridge converter

The converters are built with the IGBT/Diode block which is the basic building block of all VSCs. You may replace these blocks by individual IGBT and diode blocks for a more detailed representation.

VSCs are controlled in open loop with the Discrete PWM Generator block available in the Extras/Discrete Control Blocks library.

IGBT/Diode

The two circuits use the same DC voltage of 400 Volts, carrier frequency of 1080 Hz and modulation index of 0.8.

DC/AC Half-bridge Inverter

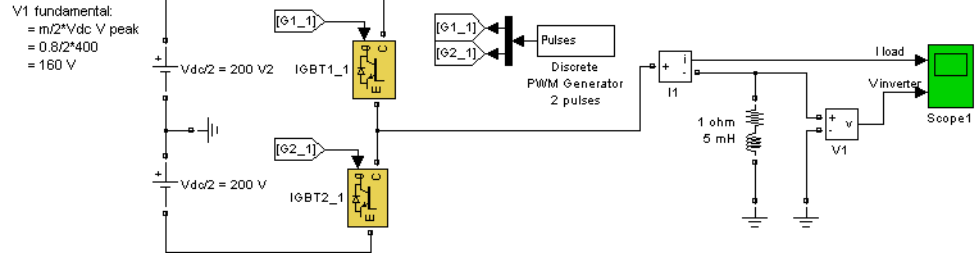

DC/AC Full-bridge Inverter

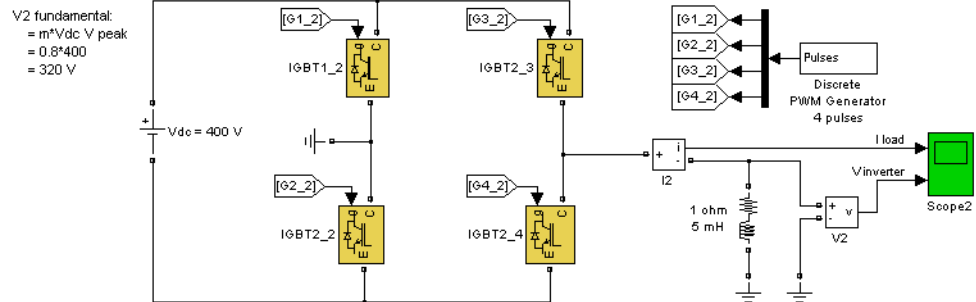

Run the simulation and observe the current into the load (trace 1) and the voltage generated by the PWM inverter (trace 2) on the Scope blocks.

See Also

IGBT, Diode

Purpose Measure the impedance of a circuit as a function of frequency

Library Measurements

Description The Impedance Measurement block measures the impedance between two nodes of a linear circuit as a function of the frequency. It consists of a current source I_z , connected between inputs one and two of the Impedance Measurement block, and a voltage measurement V_z , connected across the terminals of the current source. The network impedance is calculated as the transfer function $H(s)$ from the current input to the voltage output of the state-space model.



$$H(s) = \frac{V_z(s)}{I_z(s)}$$

The impedance (magnitude and phase) as function of frequency is displayed by using the Impedance vs Frequency Measurement tool of the Powergui block.

The measurement takes into account the initial states of the Breaker and Ideal Switch blocks. It also allows impedance measurements with Distributed Parameter Line blocks in your circuit.

Dialog Box and Parameter

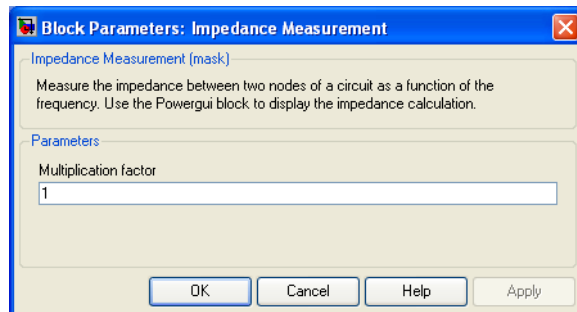

Multiplication factor

If you use the Impedance Measurement block in a three-phase circuit, you can use the **Multiplication factor** parameter to rescale the measured impedance. For example, measuring the impedance between two phases of a three-phase circuit gives two times the positive-sequence impedance.

Impedance Measurement

Therefore you must apply a multiplication factor of $1/2$ to the impedance in order to obtain the correct positive-sequence impedance value.

Similarly, to measure the zero-sequence impedance of a balanced three-phase circuit, you can connect the Impedance Measurement block between ground or neutral and the three phases connected together.

In that case, you are measuring one third of the zero-sequence impedance and you must apply a multiplication factor of 3 to obtain the correct zero-sequence value.

Limitations

The only nonlinear blocks that are taken into account during the impedance measurement are the Breaker, Three-Phase Breaker, Three-Phase Fault, Ideal Switch, and Distributed Parameter Line blocks. All other nonlinear blocks, such as machines and power electronic devices, are not considered, and they are disconnected during the measurement.

If you plan to connect the Impedance Measurement block in series with an inductance, a current source, or any nonlinear element, you must add a large resistor across the terminals of the block, because the Impedance Measurement block is simulated as a current source block.

Example

See the Powergui block reference page for an example using the Impedance Measurement block.

See Also

Powergui

Purpose Implement a two-winding or three-winding linear transformer

Library Elements

Description The Linear Transformer block model shown consists of three coupled windings wound on the same core.

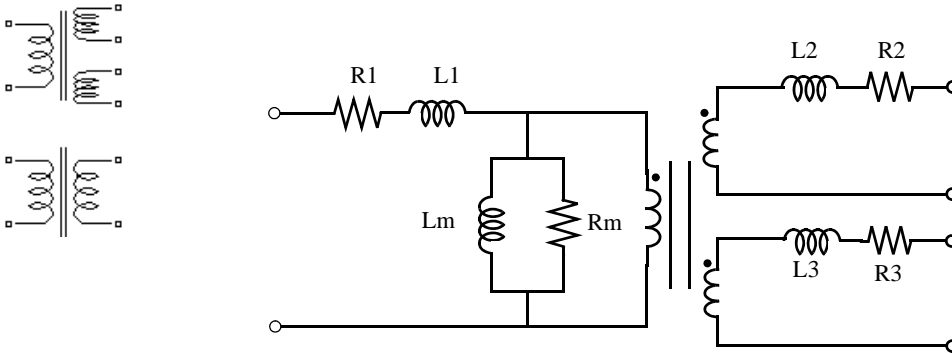

The model takes into account the winding resistances (R_1 R_2 R_3) and the leakage inductances (L_1 L_2 L_3), as well as the magnetizing characteristics of the core, which is modeled by a linear (R_m L_m) branch.

The Per Unit Conversion

In order to comply with industry, you must specify the resistance and inductance of the windings in per unit (p.u.). The values are based on the transformer rated power P_n , in VA, nominal frequency f_n , in Hz, and nominal voltage V_n , in V_{rms} , of the corresponding winding. For each winding, the per unit resistance and inductance are defined as

$$R(\text{p.u.}) = \frac{R(\Omega)}{R_{base}}$$

$$L(\text{p.u.}) = \frac{L(H)}{L_{base}}$$

Linear Transformer

The base resistance and base inductance used for each winding are

$$R_{base} = \frac{(V_n)^2}{P_n}$$

$$L_{base} = \frac{R_{base}}{2\pi f_n}$$

For the magnetization resistance R_m and inductance L_m , the p.u. values are based on the transformer rated power and on the nominal voltage of winding 1.

For example, the default parameters of winding 1 specified in the dialog box section give the following bases:

$$R_{base} = \frac{(735e3/(\sqrt{3}))^2}{250e6} = 720.3\Omega \quad L_{base} = \frac{720.3}{2\pi 60} = 1.91H$$

Suppose that the winding 1 parameters are $R_1 = 1.44\Omega$ and $L_1 = 0.1528H$; the corresponding values to be entered in the dialog box are

$$R_1 = \frac{1.44\Omega}{720.3\Omega} = 0.002 \text{ p.u.}$$

$$L_1 = \frac{0.1528H}{1.91H} = 0.08 \text{ p.u.}$$

To specify a magnetizing current of 0.2% (resistive and inductive) based on nominal current, you must enter per unit values of $1/0.002 = 500$ p.u. for the resistance and the inductance of the magnetizing branch. Using the base values calculated previously, these per unit values correspond to $R_m = 3.6e5$ ohms and $L_m = 955$ henries.

Modeling an Ideal Transformer

To implement an ideal transformer model, set the winding resistances and inductances to 0, and the magnetization resistance and inductance (R_m L_m) to inf.

Dialog Box and Parameters

Block Parameters: Linear Transformer

Linear Transformer (mask)
Implements a three windings linear transformer.
Click the Apply or the OK button after a change to the Units popup to confirm the conversion of parameters.

Parameters

Units: pu

Nominal power and frequency [Pn(VA) fn(Hz)]:
[250e6 60]

Winding 1 parameters [V1(Vrms) R1(pu) L1(pu)]:
[735e3 0.002 0.08]

Winding 2 parameters [V2(Vrms) R2(pu) L2(pu)]:
[315e3 0.002 0.08]

Three windings transformer

Winding 3 parameters [V3(Vrms) R3(pu) L3(pu)]:
[315e3 0.002 0.08]

Magnetization resistance and reactance [Rm(pu) Lm(pu)]:
[500 500]

Measurements: None

OK Cancel Help Apply

Units

Specify the units used to enter the parameters of the Linear Transformer block. Select pu to use per unit. Select SI to use SI units. Changing the **Units** parameter from pu to SI, or from SI to pu, will automatically convert the parameters displayed in the mask of the block.

Nominal power and frequency

The nominal power rating Pn in volt-amperes (VA) and frequency fn, in hertz (Hz), of the transformer.

Winding 1 parameters

The nominal voltage V, in volts RMS, resistance, in p.u. or Ohms, and leakage inductance, in p.u. or Henrys. The p.u. values are based on the nominal power Pn and on V1. Set the winding resistances and inductances to 0 to implement an ideal winding.

Winding 2 parameters

The nominal voltage V2 in volts RMS, resistance, in p.u. or Ohms, and leakage inductance, in p.u. or Henrys. The p.u. values are based on the

Linear Transformer

nominal power P_n and on V_2 . Set the winding resistances and inductances to 0 to implement an ideal winding.

Three windings transformer

If selected, implements a linear transformer with three windings; otherwise, it implements a two-windings transformer.

Winding 3 parameters

The **Winding 3 parameters** parameter is not available if the **Three windings transformer** parameter is not selected.

The nominal voltage in volts RMS (V_{rms}), resistance, in p.u. or Ohms, and leakage inductance in p.u or Henrys. The p.u. values are based on the nominal power P_n and on V_3 . Set the winding resistances and inductances to 0 to implement an ideal winding.

Magnetization resistance and reactance

The resistance and inductance simulating the core active and reactive losses. When selected, the p.u. values are based on the nominal power P_n and on V_1 . For example, to specify 0.2% of active and reactive core losses, at nominal voltage, use $R_m = 500$ p.u. and $L_m = 500$ p.u.

R_m must have a finite value when the inductance of winding 1 is greater than zero.

Measurements

Select **Winding voltages** to measure the voltage across the winding terminals of the Linear Transformer block.

Select **Winding currents** to measure the current flowing through the windings of the Linear Transformer block.

Select **Magnetization current** to measure the magnetization current of the Linear Transformer block.

Select **All voltages and currents** to measure the winding voltages and currents plus the magnetization current.

Place a **Multimeter** block in your model to display the selected measurements during the simulation.

In the **Available Measurements** list box of the Multimeter block, the measurements are identified by a label followed by the block name.

Measurement	Label
Winding voltages	Uw1 : , Uw2 : , Uw3 :
Winding currents	Iw1 : , Iw2 : , Iw3 :
Magnetization current	Imag :

Limitations

Windings can be left floating (that is, not connected to the rest of the circuit). However, an internal resistor is automatically added between the floating winding and the main circuit. This internal connection does not affect voltage and current measurements.

Example

The power_transformer demo shows a typical residential distribution transformer network feeding line-to-neutral and line-to-line loads.

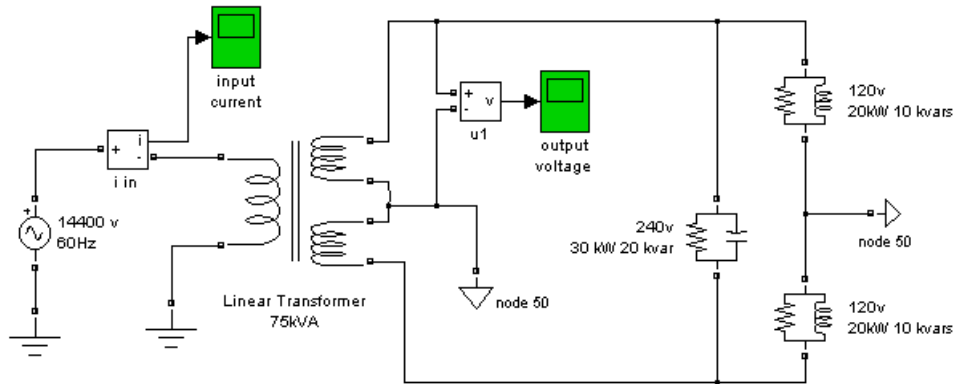

See Also

Mutual Inductance, Saturable Transformer, Three-Phase Transformer (Two Windings), Three-Phase Transformer (Three Windings)

Machine Measurement Demux

Purpose Split measurement signal of machine models into separate signals

Library Machines

Description **Note** This block is now obsolete. We strongly recommend to use the Bus Selector block from Simulink library to demux the measurement signals of the machine blocks.

Purpose Implement a mechanical shaft

Library Electric Drives/Shfts and Speed Reducers

Description The model outputs the transmitted torque through the shaft regarding the speed difference between the driving side and the loaded side of the shaft.

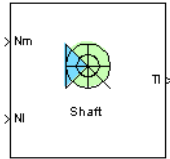

The transmitted torque T_l is given by the following equation:

$$T_l = K \int (\omega_m - \omega_l) dt + B(\omega_m - \omega_l)$$

where K (N.m) is the shaft stiffness, B (N.m.s) is the internal damping, and ω_m and ω_l are the speeds (rad/s) of the driving side and the loaded side, respectively. The following figure shows the internal schematic of the model. In this model the speeds are converted from rpm to rad/s.

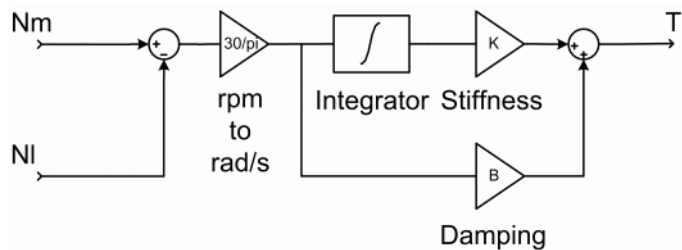

Mechanical Shaft Model Schematic

The stiffness is defined as

$$K = \frac{T}{\theta}$$

where T is the torsional torque applied to the shaft and θ the resulting angular deflection (rad).

The stiffness can also be determined by

$$K = \frac{G \cdot J}{l}$$

where G is the shear modulus, J the polar moment of inertia, and l the length of the shaft.

Mechanical Shaft

For steel, the shear modulus G is usually equal to about 80 GPa, and the polar moment of inertia J of a shaft with a circular section of diameter D is given by

$$J = \frac{\pi \cdot D^4}{32}$$

Mechanical shafts have very small angular deflections to avoid bearing problems. As an example, the following table gives the corresponding stiffness for angular deflections of 0.1 degrees at maximum torque with respect to the power and speed of electrical motors connected to the driving end of the shaft. The maximum torque is here assumed to be 1.5 times bigger than the nominal torque.

Shaft Stiffness K

P (HP)	N (rpm)	T (N.m)	Tmax (N.m) (=1.5 T)	K (N.m)
5	1750	20	30	17190
200	1750	815	1223	700730
200	1200	1190	1785	1022730

The damping factor B represents internal friction. This factor increases with the shaft stiffness. As an example, the following table gives some values of B for the stiffness of the preceding table.

Shaft Internal Damping B

K (N.m)	B (N.m.s)
17190	600
700730	24460
1022730	35700

Simulink Schematic

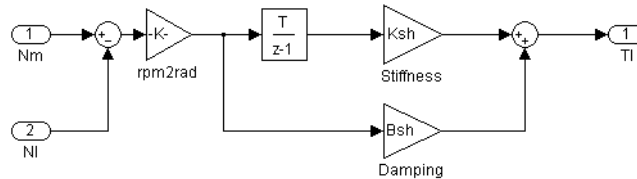

Remarks

The stiffness must be high enough to avoid large angular deflections that could cause misalignment inside the bearings and damage.

For proper simulation results, the internal damping must be high enough to avoid undesired transient speed and torque oscillations.

The model is discrete. Good simulation results have been obtained with a 10 μ s time step.

Dialog Box

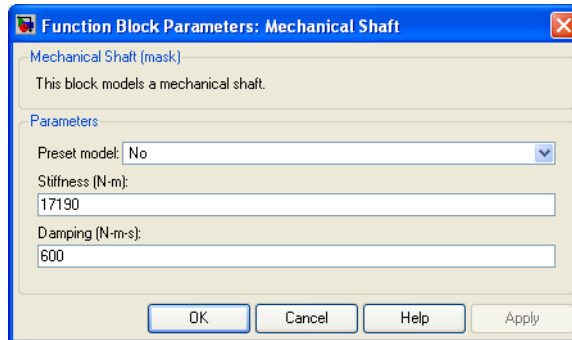

Preset Model

This pop-up menu allows you to choose preset model parameters.

Stiffness

The stiffness of the shaft (N.m).

Damping

The internal damping of the shaft (N.m.s).

Mechanical Shaft

Block Inputs and Outputs

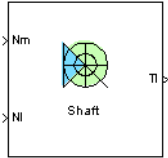

Inputs

The block has two inputs: N_m and N_l .

The first input, N_m , is the speed (rpm) of the driving end of the shaft.

The second input, N_l , is the speed (rpm) of the load connected to the second end of the shaft.

Outputs

The block has one output: T_l .

The T_l output is the torque transmitted from the driving end of the shaft to the load.

Model Specifications

The library contains three preset models. The nominal torques of these mechanical shaft models are shown in the following table:

Preset Mechanical Shaft Models

	1st	2nd	3rd
Nominal torque (N.m)	20	815	1190

The preset models have been designed in order to present 0.1 degrees of angular deflection at maximum torque (supposed to be 1.5 times the nominal torque).

Example

The `shaft_example` demo illustrates the mechanical shaft model.

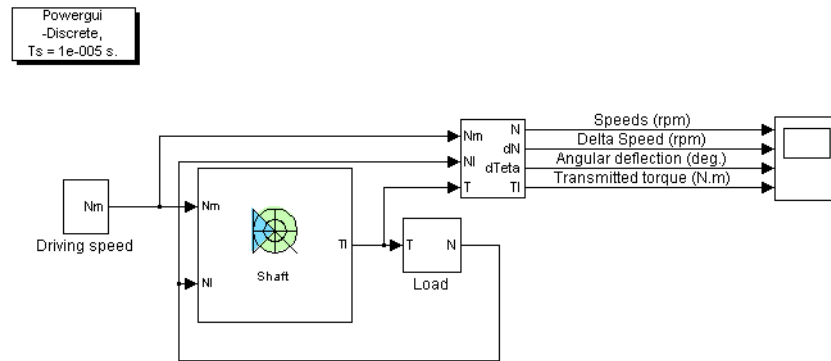

Mechanical Shaft

Double click on the Help button (?) for details



The shaft is driven by a variable speed source and is connected to a load. The load has an inertia of 0.35 kg.m² and a viscous friction term of 0.006 N.m.s.

The shaft has a stiffness of 17190 N.m and an internal damping factor of 600 N.m.s. This shaft is designed to have 0.1 degree of angular deflection for a 30 N.m load torque.

At $t = 0$ s, the driving speed starts climbing to 1750 rpm with a 500 rpm/s acceleration ramp. The angular deflection jumps to about 0.06 degree and the shaft transmits about 18.5 N.m to the load in order to accelerate it. At $t = 0.2$ s, the driving and load speeds tend to equalize. During the acceleration phase, the angular deflection increases slowly in order to transmit a higher torque to compensate the viscous friction increase.

At $t = 3.5$ s, the driving speed settles at 1750 rpm. This reduces the angular deflection and also the transmitted torque, which settles around 1.1 N.m to compensate the viscous friction of the load.

At $t = 5$ s, the driving speed lowers towards 0 rpm with a -500 rpm/s deceleration ramp. The angular deflection becomes negative and thus the transmitted torque in order to decelerate the load. During the deceleration phase, the angular deflection increases in order to transmit a higher deceleration torque to compensate the reduction of viscous friction.

Mechanical Shaft

At $t = 8.5$ s, the driving speed stabilizes at 0 rpm. This causes the angular deflection to decrease to 0 degree, the transmitted torque becomes null, and the load stops.

The following figure shows the speeds of the driving and loaded sides, the speed difference between both sides, the angular deflection, and the transmitted torque.

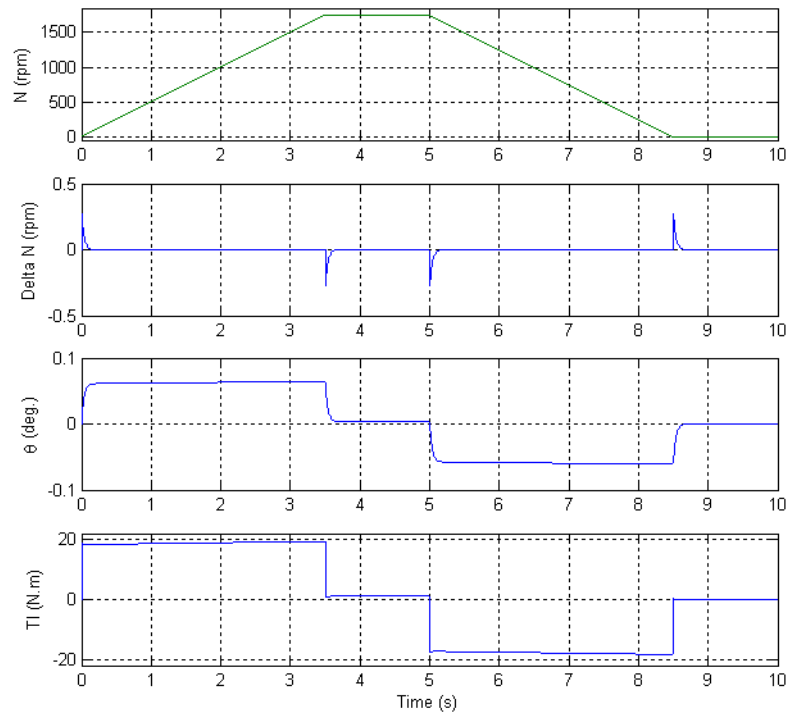

References

- [2] Norton, Robert L., *Machine Design*, Prentice Hall, 1998.
- [3] Nise, Norman S., *Control Systems Engineering*, Addison-Wesley Publishing Company, 1995.

Purpose Implement a MOSFET model

Library Power Electronics

Description

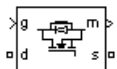

The metal-oxide semiconductor field-effect transistor (MOSFET) is a semiconductor device controllable by the gate signal ($g > 0$). The MOSFET device is connected in parallel with an internal diode that turns on when the MOSFET device is reverse biased ($V_{ds} < 0$) and no gate signal is applied ($g=0$). The model is simulated by an ideal switch controlled by a logical signal ($g > 0$ or $g = 0$), with a diode connected in parallel.

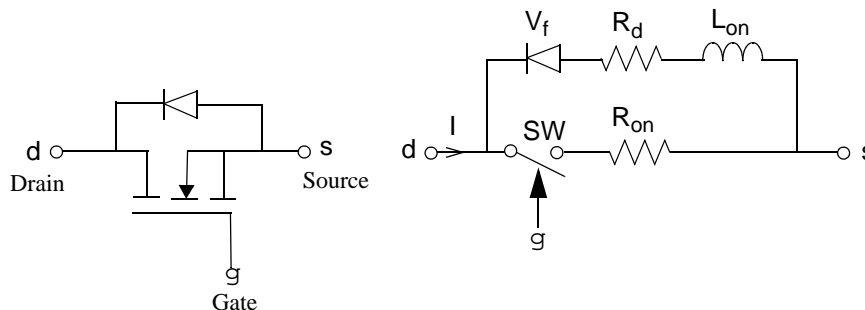

The MOSFET device turns on when a positive signal is applied at the gate input ($g > 0$) whether the drain-source voltage is positive or negative. If no signal is applied at the gate input ($g=0$), only the internal diode conducts when voltage exceeds its forward voltage V_f .

With a positive or negative current flowing through the device, the MOSFET turns off when the gate input becomes 0. If the current I is negative and flowing in the internal diode (no gate signal or $g = 0$), the switch turns off when the current I becomes 0.

The on state voltage V_{ds} varies

- $V_{ds} = R_{on} \cdot I$ when a positive signal is applied at the gate input.
- $V_{ds} = R_d \cdot I - V_f + L_{on} \cdot dI/dt$ when the antiparallel diode is conducting (no gate signal).

MOSFET

The Lon diode inductance is available only with the continuous model. For most applications, Lon should be set to zero for both continuous and discrete models.

The MOSFET block also contains a series Rs-Cs snubber circuit that can be connected in parallel with the MOSFET (between nodes d and s).

Dialog Box and Parameters

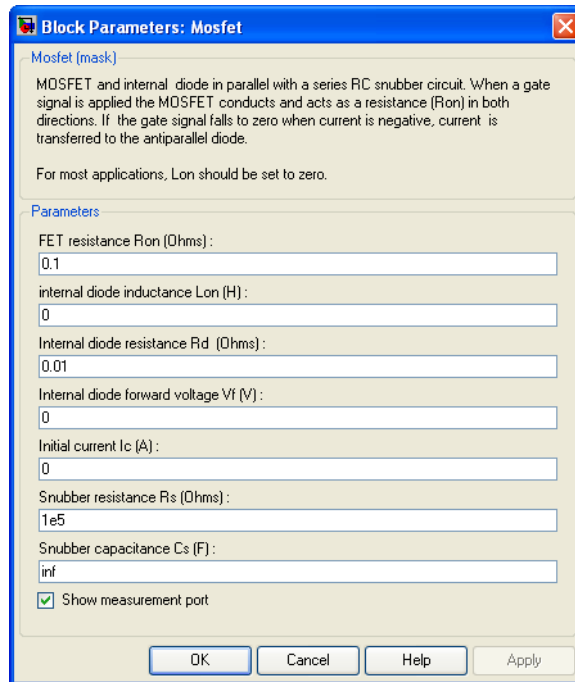

FET Resistance Ron

The internal resistance Ron, in ohms (Ω).

Internal diode inductance Lon

The internal inductance Lon, in henries (H). The **Inductance Lon** parameter cannot be set to 0.

Internal diode resistance Rd

The internal resistance of the internal diode, in ohms (Ω).

Internal diode forward voltage Vf

The forward voltage of the internal diode, in volts (V).

Initial current Ic

You can specify an initial current flowing in the MOSFET device. It is usually set to 0 in order to start the simulation with the device blocked.

If the **Initial current IC** parameter is set to a value greater than 0, the steady-state calculation of SimPowerSystems considers the initial status of the MOSFET as closed. Initializing all states of a power electronic converter is a complex task. Therefore, this option is useful only with simple circuits.

Snubber resistance Rs

The snubber resistance, in ohms (Ω). Set the **Snubber resistance Rs** parameter to `inf` to eliminate the snubber from the model.

Snubber capacitance Cs

The snubber capacitance, in farads (F). Set the **Snubber capacitance Cs** parameter to 0 to eliminate the snubber, or to `inf` to get a resistive snubber.

Show measurement port

If selected, add a Simulink output to the block returning the MOSFET current and voltage.

Inputs and Outputs

g

Simulink signal to control the opening and closing of the MOSFET.

m

The Simulink output of the block is a vector containing 2 signals. You can demultiplex these signals by using the Bus Selector block provided in the Simulink library.

Signal	Definition	Units
1	MOSFET current	A
2	MOSFET voltage	V

MOSFET

Assumptions and Limitations

The MOSFET block implements a macro model of the real MOSFET device. It does not take into account either the geometry of the device or the complex physical processes [1].

Depending on the value of the inductance L_{on} , the MOSFET is modeled either as a current source ($L_{on} > 0$) or as a variable topology circuit ($L_{on} = 0$). The MOSFET block cannot be connected in series with an inductor, a current source, or an open circuit, unless its snubber circuit is in use. See Chapter 3, “Improving Simulation Performance” for more details on this topic.

Use the Powergui block to specify either continuous simulation or discretization of your electrical circuit containing MOSFET blocks. When using a continuous model, the ode23t stiff solver with a relative tolerance of $1e-4$ is recommended for best accuracy and simulation speed.

The inductance L_{on} is forced to 0 if you choose to discretize your circuit.

Example

The power_mosconv demo illustrates the use of the MOSFET block in a zero-current quasi-resonant switch converter. In such a converter, the current produced by the Lr-Cr resonant circuit flows through the MOSFET and internal diode. The negative current flows through the internal diode that turns off at 0 current [1]. The switching frequency is 2 MHz and the pulse width is 72 degrees (duty cycle: 20%).

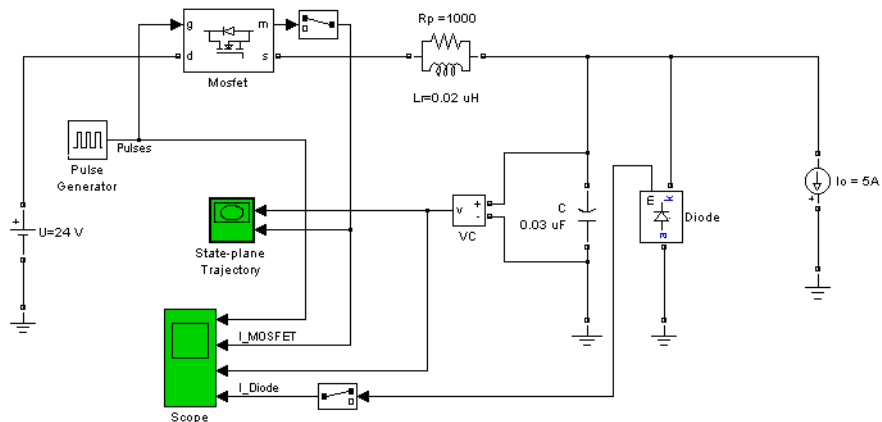

Run the simulation and observe the gate pulse signal, the MOSFET current, the capacitor voltage, and the diode current on the four-trace Scope block.

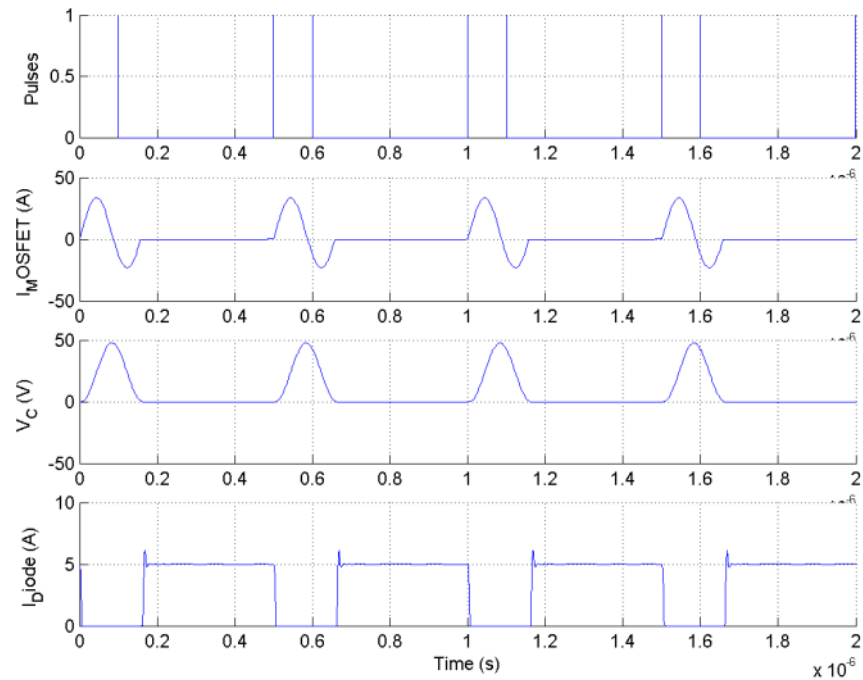

References

[1] Mohan, N., T.M. Undeland, and W.P. Robbins, *Power Electronics: Converters, Applications, and Design*, John Wiley & Sons, Inc., New York, 1995.

See Also

Diode, GTO, Ideal Switch, Three-Level Bridge, Thyristor, Universal Bridge

Multiband Power System Stabilizer

Purpose Implement a multiband power system stabilizer

Library Machines

Description

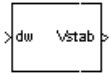

The disturbances occurring in a power system induce electromechanical oscillations of the electrical generators. These oscillations, also called power swings, must be effectively damped to maintain the system's stability.

Electromechanical oscillations can be classified in four main categories:

- Local oscillations: between a unit and the rest of the generating station and between the latter and the rest of the power system. Their frequencies typically range from 0.8 to 4.0 Hz.
- Interplant oscillations: between two electrically close generation plants. Frequencies can vary from 1 to 2 Hz.
- Interarea oscillations: between two major groups of generation plants. Frequencies are typically in a range of 0.2 to 0.8 Hz.
- Global oscillation: characterized by a common in-phase oscillation of all generators as found on an isolated system. The frequency of such a global mode is typically under 0.2 Hz.

The need for effective damping of such a wide range, almost two decades, of electromechanical oscillations motivated the concept of the multiband power system stabilizer (MB-PSS).

As its name reveals, the MB-PSS structure is based on multiple working bands. Three separate bands are used, respectively dedicated to the low-, intermediate-, and high-frequency modes of oscillations: the low band is typically associated with the power system global mode, the intermediate with the interarea modes, and the high with the local modes.

Each of the three bands is made of a differential bandpass filter, a gain, and a limiter (see the figure called "Conceptual Representation" on page 7-227). The outputs of the three bands are summed and passed through a final limiter producing the stabilizer output V_{stab} . This signal then modulates the set point of the generator voltage regulator so as to improve the damping of the electromechanical oscillations.

To ensure robust damping, the MB-PSS should include a moderate phase advance at all frequencies of interest to compensate for the inherent lag

Multiband Power System Stabilizer

between the field excitation and the electrical torque induced by the MB-PSS action.

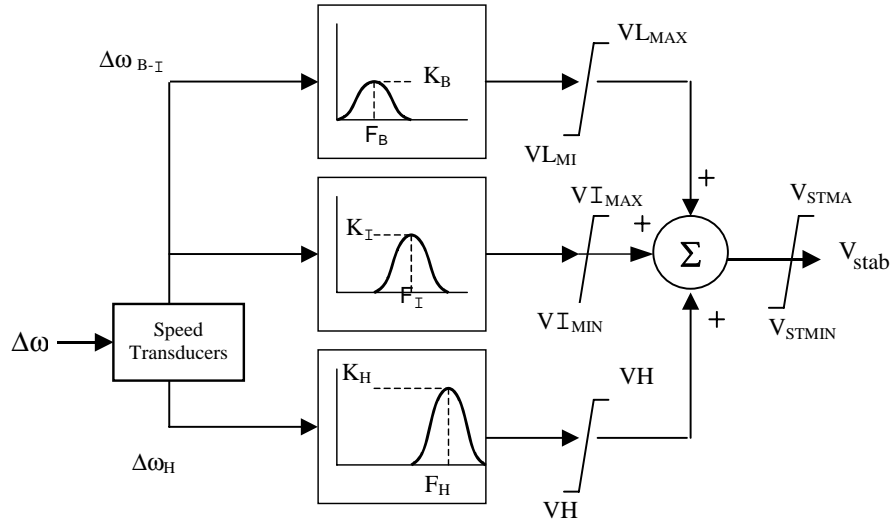

Conceptual Representation

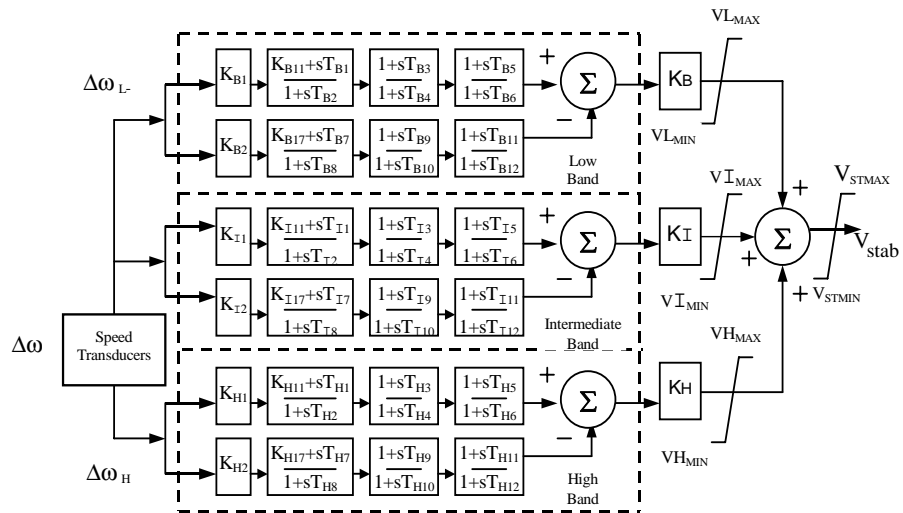

Internal Specifications

Multiband Power System Stabilizer

The MB-PSS is represented by the IEEE St. 421.5 PSS 4B type model [2], illustrated in the figure called “Internal Specifications” on page 7-227, with built-in speed transducers whose parameters are fixed according to manufacturer’s specifications.

Generally, only a few of the lead-lag blocks in this figure should be used in a given PSS application. Two different approaches are available to configure the settings in order to facilitate the tuning process:

1 Simplified settings:

Only the first lead-lag block of each frequency band is used to tune the Multiband Power System Stabilizer block. The differential filters are assumed to be symmetrical bandpass filters respectively tuned at the center frequency F_L , F_I , and F_H . The peak magnitude of the frequency responses (see the figure called “Conceptual Representation” on page 7-227) can be adjusted independently through the three gains K_L , K_I , and K_H . Only six parameters are therefore required for a simplified tuning of the MB-PSS.

2 Detailed settings:

The designer is free to use all the flexibility built into the MB-PSS structure to achieve nontrivial controller schemes and to tackle even the most constrained problem (for example, multi unit plant including an intermachine mode, in addition to a local mode and multiple interarea modes). In this case, all the time constants and gains appearing in the figure called “Internal Specifications” have to be specified in the dialog box.

Multiband Power System Stabilizer

Dialog Box and Simplified Settings Mode Parameters

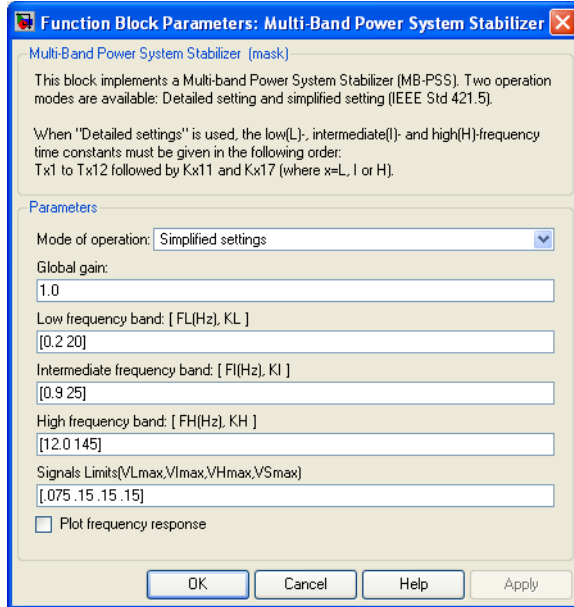

Global gain

The overall gain K of the multiband power system stabilizer.

Low frequency band: [FL KL]

The center frequency, in hertz, and peak gain of the low-frequency bandpass filter.

Intermediate frequency band: [FI KI]

The center frequency, in hertz, and peak gain of the intermediate-frequency bandpass filter.

High frequency band: [FH KH]

The center frequency, in hertz, and peak gain of the high-frequency bandpass filter.

Multiband Power System Stabilizer

Signal limits [VLmax VImax VHmax VSmax]

The limits imposed on the output of the low-, intermediate-, and high-frequency bands and the limit VSmax imposed on the output of the stabilizer, all in p.u.

Plot frequency response

If selected, a plot of the frequency response of the stabilizer is displayed when you click the **Apply** button.

Detailed Settings Mode

Function Block Parameters: Multi-Band Power System Stabilizer

Multi-Band Power System Stabilizer (mask)

This block implements a Multi-band Power System Stabilizer (MB-PSS). Two operation modes are available: Detailed setting and simplified setting (IEEE Std 421.5).

When "Detailed settings" is used, the low(L)-, intermediate(I)- and high(H)-frequency time constants must be given in the following order:
Tx1 to Tx12 followed by Kx11 and Kx17 (where x=L, I or H).

Parameters

Mode of operation: Detailed settings

Low frequency gains: [KL1, KL2, KL]
[66 66 9.4]

Low frequency time constants (s):
[1.667 2 0 0 0 2.2 4 0 0 0 1 1]

Intermediate frequency gains: [KI1, KI2, KI]
[66 66 47.6]

Intermediate frequency time constants (s):
[1 1 0.25 0.3 0 0 1 1 0.3 0.36 0 0 0 0]

High frequency gains: [KH1, KH2, KH]
[66 66 233]

High frequency time constants (s):
[0.01 0.012 0 0 0 0 0.012 0.0144 0 0 0 0 1 1]

Signals Limits(VLmax,VImax,VHmax,VSmax)
[.075 .15 .15 .15]

Plot frequency response

OK Cancel Help Apply

Low frequency gains: [KL1 KL2 KL]

The gains of the positive and negative branches of the differential filter in the low-frequency band and the overall gain K_L of the low-frequency band, in p.u.

Low frequency time constants

The time constants, in seconds, of the lead-lag blocks in the positive and negative branches of the low-frequency filter. You need to specify the following twelve time constants and two gains:

[T_{B1} T_{B2} T_{B3} T_{B4} T_{B5} T_{B6} T_{B7} T_{B8} T_{B9} T_{B10} T_{B11} T_{B12} K_{B11} K_{B17}]

Set K_{B11} to 0 in order to make the first block of the positive filter branch a washout block. Set K_{B11} to 1 in order to make the block a lead-lag block.

Set K_{B17} to 0 in order to make the first block of the negative filter branch a washout block. Set K_{B17} to 1 in order to make the block a lead-lag block.

Intermediate frequency gains: [KI1 KI2 KI]

The gains of the positive and negative branches of the differential filter in the intermediate-frequency band and the overall gain K_I of the intermediate-frequency band, in p.u.

Intermediate frequency time constants

The time constants, in seconds, of the lead-lag blocks in the positive and negative branches of the intermediate-frequency filter. You need to specify the following twelve time constants and two gains:

[T_{I1} T_{I2} T_{I3} T_{I4} T_{I5} T_{I6} T_{I7} T_{I8} T_{I9} T_{I10} T_{I11} T_{I12} K_{I11} K_{I17}]

Set K_{I11} to 0 in order to make the first block of the positive filter branch a washout block. Set K_{I11} to 1 in order to make the block a lead-lag block.

Set K_{I17} to 0 in order to make the first block of the negative filter branch a washout block. Set K_{I17} to 1 in order to make the block a lead-lag block.

High frequency gains: [KH1 KH2 KH]

The gains of the positive and negative branches of the differential filter in the high-frequency band and the overall gain K_H of the high-frequency band, in p.u.

High frequency time constants

The time constants, in seconds, of the lead-lag blocks in the positive and negative branches of the high-frequency filter. You need to specify the following twelve time constants and two gains:

[T_{H1} T_{H2} T_{H3} T_{H4} T_{H5} T_{H6} T_{H7} T_{H8} T_{H9} T_{H10} T_{H11} T_{H12} K_{H11} K_{H17}]

Multiband Power System Stabilizer

Set K_{H11} to 0 in order to make the first block of the positive filter branch a washout block. Set K_{H11} to 1 in order to make the block a lead-lag block.

Set K_{H17} to 0 in order to make the first block of the negative filter branch a washout block. Set K_{H17} to 1 in order to make the block a lead-lag block.

Signal limits [VLmax VImax VHmax VSmax]

The limits imposed on the output of the low-, intermediate-, and high-frequency bands and the limit VSmax imposed on the output of the stabilizer, all in p.u.

Plot frequency response

If selected, a plot of the frequency response of the stabilizer is displayed when you click the **Apply** button.

Input and Output

dw

Connect to the first input the synchronous machine speed deviation dw signal (in p.u.).

Vstab

The output is the stabilization voltage, in p.u., to connect to the vstab input of the Excitation System block used to control the terminal voltage of the block.

Example

See the help text of the power_PSS demo model.

References

[1] Grondin, R., I. Kamwa, L. Soulieres, J. Potvin, and R. Champagne, "An approach to PSS design for transient stability improvement through supplementary damping of the common low frequency," *IEEE Transactions on Power Systems*, **8**(3), August 1993, pp. 954-963.

[2] IEEE recommended practice for excitation system models for power system stability studies: *IEEE St. 421.5-2002* (Section 9).

See Also

Generic Power System Stabilizer

Purpose Measure the voltages and currents specified in dialog boxes of SimPowerSystems blocks

Library Measurements

Description The Multimeter block is used to measure voltages and currents of the measurements described by the dialog boxes of SimPowerSystems blocks.



The **powerlib** blocks listed in the following table have a special parameter (**Measurements**) that allows you to measure voltages or currents related to the block. Choosing voltages or currents through this measurement parameter is equivalent to connecting an internal voltage or current measurement block inside your blocks. The measured signals can be observed through a Multimeter block placed in your circuit.

Drag the Multimeter block into the top-level system of your circuit and double-click the icon to open the dialog box.

Block Name	Block Name
AC Current Source	PI Section Line
AC Voltage Source	Saturable Transformer
Breaker	Series RLC Branch
Controlled Current Source	Series RLC Load
Controlled Voltage Source	Surge Arrester
DC Voltage Source	Three-Level Bridge
Distributed Parameter Line	Three-Phase Harmonic Filter
Linear Transformer	Three-Phase Load (Series and Parallel)
Multi-Winding Transformer	Three-Phase Branch (Series and Parallel)

Multimeter

Block Name (Continued)	Block Name (Continued)
Mutual Inductance	Three-Phase Transformer (Two and Three Windings)
Parallel RLC Branch	Universal Bridge
Parallel RLC Load	Zigzag Phase-Shifting Transformer

Sign Conventions for Voltages and Currents

When you measure a current using a Current Measurement block, the positive direction of current is indicated on the block icon (positive current flowing from + terminal to – terminal). Similarly, when you measure a voltage using a Voltage Measurement block, the measured voltage is the voltage of the + terminal with respect to the – terminal. However, when voltages and currents of blocks from the Elements library are measured using the Multimeter block, the voltage and current polarities are not immediately obvious because blocks might have been rotated and there are no signs indicating polarities on the block icons.

Unlike Simulink signal lines and input and output ports, the Physical Modeling connection lines and terminal ports □ of SimPowerSystems lack intrinsic directionality. The voltage and current polarities are determined, not by line direction, but instead by block orientation. To find out a block orientation, first click the block to select it. Then enter the following command:

```
get_param(gcf, 'Orientation')
```

The following table indicates the polarities of the currents and voltages measured with the Multimeter block for single-phase and three-phase RLC elements (branches or loads), surge arresters, and single-phase and

three-phase breakers. The table also indicates the polarities of their state variables (inductor currents and capacitor voltages).

Block Orientation	Positive Current Direction	Measured Voltage
right	left → right	$V_{\text{left}} - V_{\text{right}}$
left	right → left	$V_{\text{right}} - V_{\text{left}}$
down	top → bottom	$V_{\text{top}} - V_{\text{bottom}}$
up	bottom → top	$V_{\text{bottom}} - V_{\text{top}}$

The natural orientation of the blocks (that is, their orientation in the Element library) is *right* for horizontal blocks and *down* for vertical blocks.

For single-phase transformers (linear or saturable), with the winding connectors appearing on the left and right sides, the winding voltages are the voltages of the top connector with respect to the bottom connector whatever the block orientation (*right* or *left*). The winding currents are the currents entering the top connector.

For three-phase transformers, the voltage polarities and positive current directions are indicated by the signal labels used in the Multimeter block. For example, $U_{\text{an_w2}}$ = phase A-to-neutral voltage of the Y connected winding #2, $I_{\text{ab_w1}}$ = winding current flowing from A to B in the delta-connected winding #1.

Multimeter

Dialog Box and Parameters

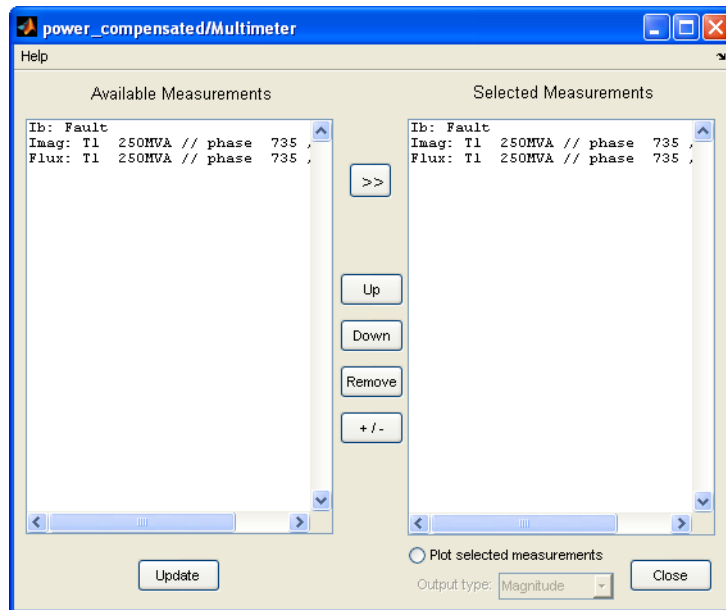

Available Measurements

The **Available Measurements** list box shows the measurements in the Multimeter block. Use the >> button to select measurements from the **Available Measurements** list box. Click the **Update** button to refresh the list of available measurements in the Multimeter block.

The measurements in the list box are identified by the name of the block where the measurement is done. The type of measurement (voltage measurement, current measurement, or flux) is defined by a label preceding the block name. See the reference sections of blocks listed in the previous table for a description of these measurements.

Selected Measurements

The **Selected Measurements** list box shows the measurements sent to the output of the block. You can reorder the measurements by using the **Up**, **Down**, and **Remove** buttons. The +/- button allows you to reverse the polarity of any selected measurement.

Plot selected measurements

If selected, displays a plot of selected measurements using a MATLAB figure window. The plot is generated when the simulation stops.

Output type

Specifies the format of the output signals when the block is used in a phasor simulation. The **Output signal** parameter is disabled when the block is not used in a phasor simulation. The phasor simulation is activated by a Powergui block placed in the model.

Set to Complex to output the selected measurements as complex values. The outputs are complex signals.

Set to Real - Imag to output the real and imaginary parts of the measurements. For each selected measurement, the multimeter outputs the real and imaginary parts.

Set to Magnitude - Angle to output the magnitude and angle of the selected measurements. For each selected measurement, the multimeter outputs the magnitude and angle values.

Set to Magnitude to output the magnitude of the selected measurements.

Example

The power_compensated demo uses a Multimeter block to measure the voltage across the secondary winding of a Saturable Transformer block and the currents flowing through two Series RLC Load blocks.

Multimeter

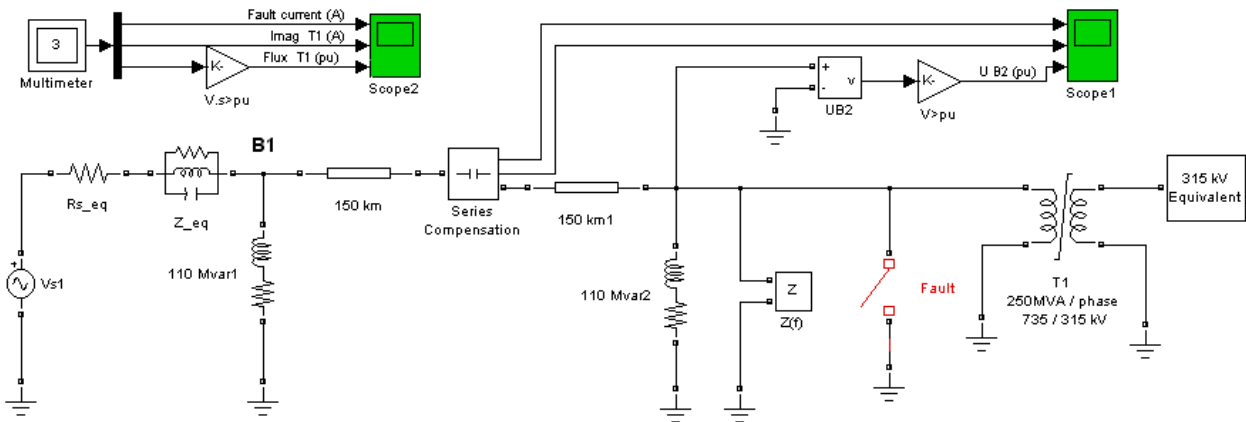

A Multimeter block is dragged into the model. In the dialog box of the 250 MVA block, set the **Measurements** parameter to All measurements (V, I, flux). In the 110 Mvar block, set it to Branch voltage and in the 110 Mvar1 block, set it to Branch voltage and current.

The output of the Multimeter block is connected to a Scope block in order to display the measurements during the simulation. In addition, you can select the **Plot selected measurements** parameter to display a plot of selected measurements when simulation stops.

Open the Multimeter block dialog box and select the signals you want to observe, as shown on the Dialog Box and Parameters section. Notice the labels used to define the available measurements in the Multimeter block. See the reference section of the Saturable Transformer block and Series RLC Load block for a description of these labels.

Start the simulation. After 0.4 seconds, the simulation stops and a MATLAB figure window opens to display the selected measurements in the Multimeter block.

See Also

Current Measurement, Voltage Measurement

Multi-Winding Transformer

Purpose Implements a multi-winding transformer with taps

Library Elements

Description

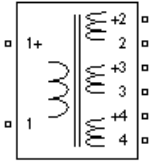

The Multi-Winding Transformer block implements a transformer where the number of windings can be specified for both the primary (left side windings) and the secondary (right side windings).

The equivalent circuit of the Multi-Winding Transformer block is similar to the one of the Linear Transformer block and the saturation characteristic of the core can be specified or not. See the Saturable Transformer block reference pages for more details on how the saturation and the hysteresis characteristic are implemented.

The equivalent circuit of a Multi-Windings Transformer block with two primary windings and three secondary windings is shown in the next figure.

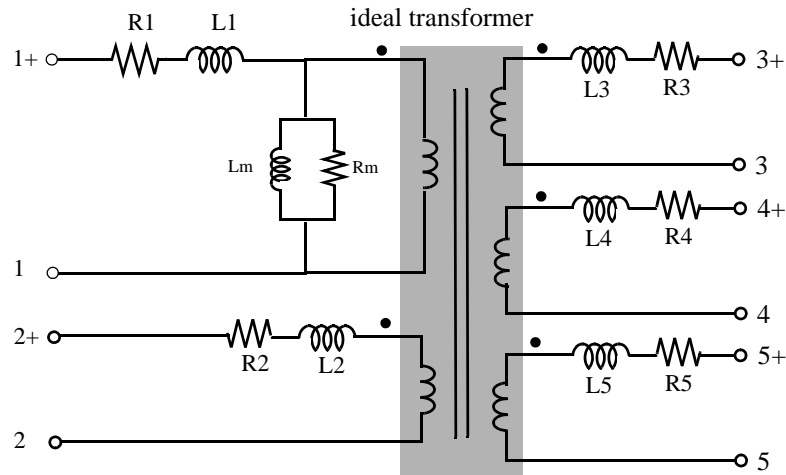

You can add equally spaced taps to the first primary winding (the upper-left winding) or to the first secondary winding (the upper-right winding). The equivalent circuit of a Multi-Winding Transformer block with one primary winding and eight taps on the first of the two secondary windings is shown in the next figure.

Multi-Winding Transformer

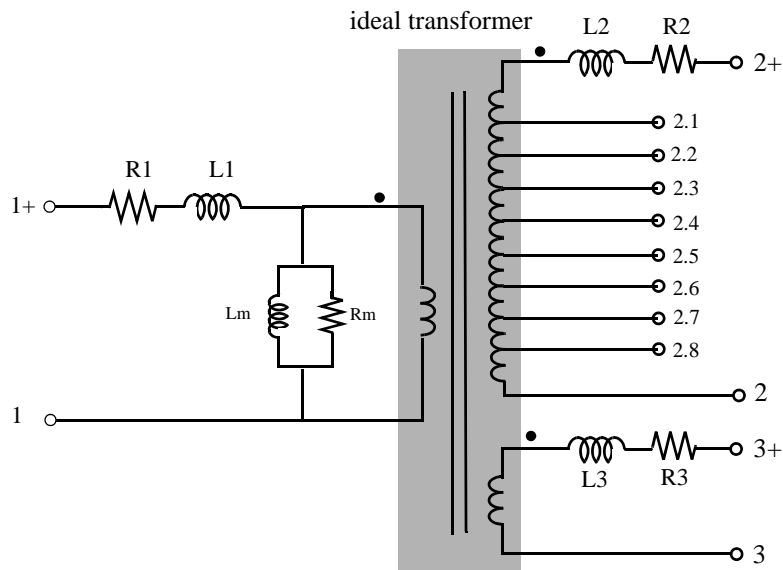

The winding terminals are identified by the corresponding winding number. The first winding is the first one on the primary side (upper-left side) and the last winding is the last one on the secondary side (bottom-right side). The polarity of the windings are defined by a plus sign.

The tap terminals are identified by their winding number followed by a dot character and the tap number. Taps are equally spaced so that voltage appearing at no load between two consecutive taps is equal to the total voltage of the winding divided by (number of taps +1). The total winding resistance and leakage inductance of a tapped winding is equally distributed along the taps.

Dialog Box and Parameters

Block Parameters: Multi-Winding Transformer

Multi-Winding Transformer (mask) (link)

Implements a transformer with multiple windings. The number of windings can be specified for the left side and for the right side of the block. Taps can be added to the upper left winding or to the upper right winding.

Parameters

Units: pu

Number of windings on left side: 1

Number of windings on right side: 3

Tapped winding: taps on upper left winding

.... Number of taps (equally spaced): 2

Nominal power and frequency [Pn(VA) fn(Hz)]: [75e3 60]

Winding nominal voltages [U1 U2 ... Un] (Vrms): [14400 120 120 120]

Winding resistances [R1 R2 ... Rn] (pu): [0.005 0.005 0.005 0.005]

Winding leakage inductances [L1 L2 ... Ln] (pu): [0.02 0.02 0.02 0.02]

Saturable core

Magnetization resistance Rm (pu): 50

Saturation characteristic (pu) [i1 , phi1 ; i2 , phi2 ; ...]: [0.0 ; 0.0024,1.2 ; 1.0,1.52]

Simulate hysteresis

.... Hysteresis Data Mat file: 'hysteresis.mat'

Measurements: None

..... Show additional parameters

Break Algebraic loop in discrete saturation model

OK Cancel Help Apply

Units

Specify the units used to enter the parameters of the Multi-Winding Transformer block. Select pu to use per unit. Select SI to use SI units. Changing the **Units** parameter from pu to SI, or from SI to pu, will automatically convert the parameters displayed in the mask of the block.

Multi-Winding Transformer

Number of windings on the left side

Specifies the number of windings on the primary side (left side) of the transformer.

Number of windings on the right side

Specifies the number of windings on the secondary side (right side) of the transformer.

Tapped winding

Select no taps if you don't want to add taps to the transformer. Select taps on upper left winding to add taps to the first winding on the primary side of the transformer. Select taps on upper right winding to add taps to the secondary winding on the right side of the transformer. The number of taps is specified by the **Number of taps (equally spaced)** parameter.

Number of taps (equally spaced)

This parameter is not visible if the **Tapped winding** parameter is set to no taps.

If the **Tapped winding** parameter is set to taps on upper left winding, you specify the number of taps to add to the first winding on the left side.

If the **Tapped winding** parameter is set to taps on upper right windings, you specify the number of taps to add to the first winding on the right side.

Nominal power and frequency

The nominal power rating, in volt-amperes (VA), and nominal frequency, in hertz (Hz), of the transformer.

Winding nominal voltages

Specify a vector containing the nominal RMS voltages, in V_{rms} , of the windings on the left side, followed by the nominal RMS voltages of the windings on the right side. You don't have to specify the individual tap nominal voltages.

Winding resistances

Specify a vector containing the resistance values of the windings on the left side, followed by the resistance values of the windings on the right side. You don't have to specify the individual tap resistances.

Winding leakage inductances

Specify a vector containing the leakage inductance values of the windings on the left side, followed by the leakage inductance values of windings on the right side. You don't have to specify the individual tap leakage inductances.

Saturable core

If selected, implements a saturable transformer.

Magnetization resistance Rm

The magnetization resistance Rm, in Ohms or in p.u.

Magnetization reactance Lm

The **Magnetization reactance Lm** parameter is not visible in the dialog box if the **Saturable core** parameter is selected.

The magnetization inductance Lm, in Henry or in p.u., for a nonsaturable core.

Saturation characteristic

This parameter is visible only if the **Saturable core** parameter is selected.

The saturation characteristic for the saturable core. Specify a series of current/ flux pairs (in p.u.) starting with the pair (0,0).

Simulate hysteresis

Select to model hysteresis saturation characteristic instead of a single-valued saturation curve.

Hysteresis Data Mat file

The **Hysteresis data MAT file** parameter is visible only if the **Simulate hysteresis** parameter is selected.

Specify a .mat file containing the data to be used for the hysteresis model. When you open the **Hysteresis Design tool** of the Powergui, the default hysteresis loop and parameters saved in the hysteresis.mat file are displayed. Use the **File** → **Load a model** menu of the **Hysteresis Design tool** to load another .mat file. Use the **File** → **Save this model** menu of the **Hysteresis Design tool** to save your model in a new .mat file.

Multi-Winding Transformer

Measurements

Select **Winding voltages** to measure the voltage across the winding terminals of the Saturable Transformer block.

Select **Winding currents** to measure the current flowing through the windings of the Saturable Transformer block.

Select **Flux** and excitation current ($I_m + I_{Rm}$) to measure the flux linkage, in volt seconds (V.s), and the total excitation current including iron losses modeled by R_m .

Select **Flux** and magnetization current (I_m) to measure the flux linkage, in volt seconds (V.s), and the magnetization current, in amperes (A), not including iron losses modeled by R_m .

Select **All measurement (V, I, Flux)** to measure the winding voltages, currents, magnetization currents, and the flux linkage.

Place a **Multimeter** block in your model to display the selected measurements during the simulation.

In the **Available Measurements** list box of the Multimeter block, the measurements are identified by a label followed by the block name.

Measurement	Label
Winding voltages	Uw1:, Uw2:, Uw3:
Winding currents	Iw1:, Iw2:, Iw3:
Excitation current	Iexc:
Magnetization current	Imag:
Flux linkage	Flux:

Example

The power_OLTCregtransformer demo uses three Multi-Winding Transformer blocks to implement a three-phase On Load Tap Changer (OLTC) transformer. Because of long simulation times required for illustrating operation of the tap changer (simulation time is set to 120 s), the demo uses the Phasor simulation method.

Multi-Winding Transformer

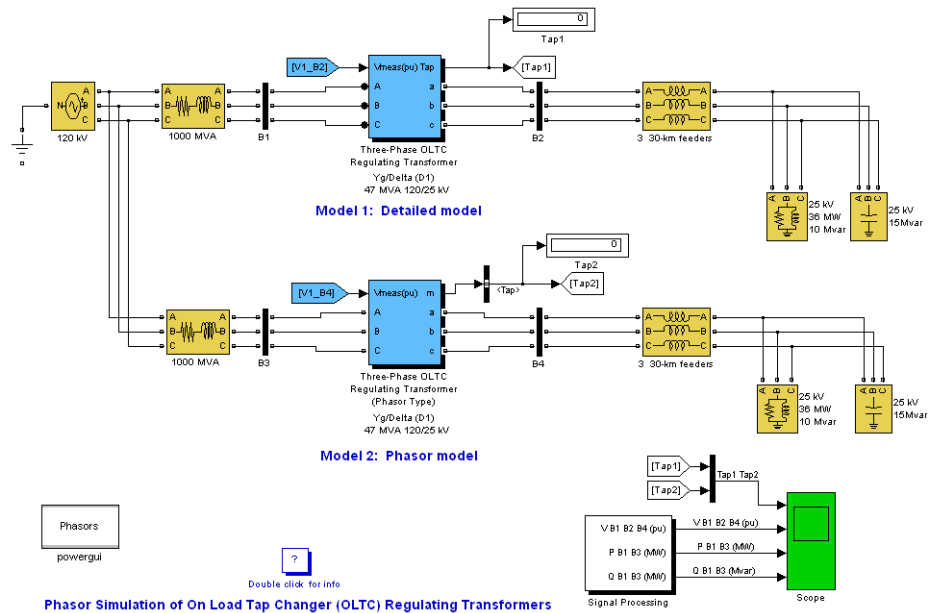

Phasor Simulation of On Load Tap Changer (OLTC) Regulating Transformers

A 25 kV distribution network consisting of three 30-km distribution feeders connected in parallel supplies power to a 36 MW /10 Mvar load (0.964 PF lagging) from a 120 kV, 1000 MVA system and a 120kV/25 kV OLTC regulating transformer. The OLTC transformer is used to regulate system voltage at the 25 kV bus.

The same circuit is duplicated to compare the performance of two different models of OLTC transformers:

- Model 1 is a detailed model where all OLTC switches and transformer windings are represented. This model uses three Multi-Winding Transformer blocks to implement a three-phase regulating transformer, with the OLTC connected on the high voltage side (120 kV). This model can be used with either continuous or discrete solvers to get detailed waveshapes or with the phasor simulation method (as in the present demo) to observe variations of phasor voltages and currents.

Multi-Winding Transformer

- Model 2 is a simplified phasor model where the transformer and OLTC are simulated by current sources. This model can be used only with the phasor solution method. It is faster to execute and it should be the preferred model for transient stability studies, when several such devices are used in the same system.

Both OLTC transformer models implement a three-phase regulating transformer rated 47 MVA, 120 kV/25 kV, Y/ Delta, with the OLTC connected on the high voltage side (120 kV).

Select the Model 1 transformer block and use the **Edit/Look_under_mask** menu to see how the regulating transformer is implemented. The OLTC transformer model is built from three Multi-Winding Transformer blocks. Each phase consists of two main windings (winding 2 = 120 kV and winding 3 = 25 kV) and one regulation winding (tapped winding 1). The seven taps of the regulation winding allow eight steps of voltage variation either in positive or negative direction. Three OLTC subsystems contain switches performing tap selection and reversal of the regulation winding.

Run the demo. Double-click the Double click for info block to get details.

Purpose Implement inductances with mutual coupling

Library Elements

Description The Mutual Inductance block can be used to model two- or three-windings inductances with equal mutual coupling, or to model a generalized multi-windings mutual inductance with balanced or unbalanced mutual coupling.

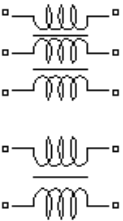

If you choose to model two- or three-windings inductances with equal mutual coupling, you specify the self-resistance and inductance of each winding plus the mutual resistance and inductance. The electrical model for this block in this case is given below:

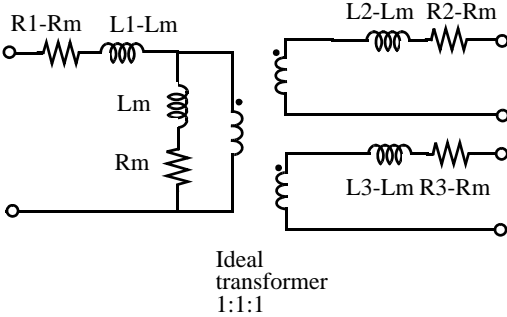

If you choose to model a general mutual inductance, you need to specify the number of self windings (not just limited to 2 or 3 windings) plus the Resistance and Inductance matrices that define the mutual coupling relationship between the windings (balanced or not).

Mutual Inductance

Dialog Box and Parameters Two or three windings inductances with equal mutual coupling:

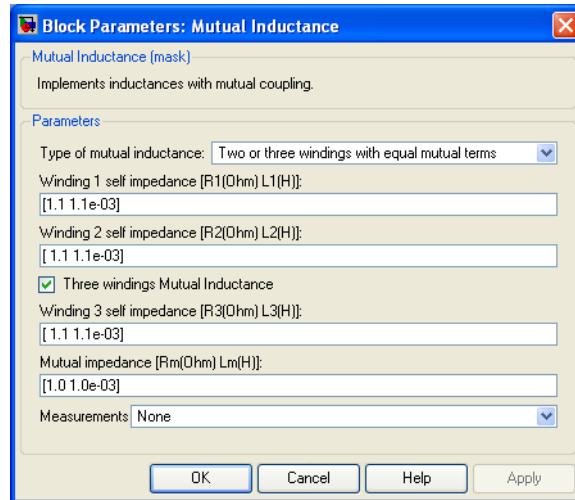

Type of mutual inductance

Set to **Two or Three windings with equal mutual terms** to implement a three-phase mutual inductance with equal mutual coupling between the windings

Winding 1 self impedance

The self-resistance and inductance for winding 1, in ohms (Ω) and henries (H).

Winding 2 self impedance

The self-resistance and inductance for winding 2, in ohms (Ω) and henries (H).

Three windings Mutual Inductance

If selected, implements three coupled windings; otherwise, it implements two coupled windings.

Winding 3 self impedance

The **Winding 3 self impedance** parameter is not available if the **Three windings Mutual Inductance** parameter is not selected. The self-resistance and inductance in ohms (Ω) and henries (H) for winding 3.

Mutual impedance

The mutual resistance and inductance between windings, in ohms (Ω) and henries (H). The mutual resistance and inductance corresponds to the magnetizing resistance and inductance on the standard transformer circuit diagram. If the mutual resistance and reactance are set to [0 0], the block implements three separate inductances with no mutual coupling.

Generalized mutual inductance:

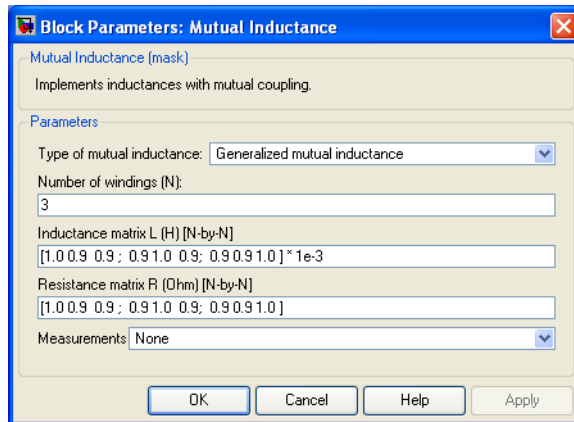

Type of mutual inductance

Set to **Generalized mutual inductance** to implement a multi windings mutual inductance with mutual coupling defined by an inductance and a resistance matrix.

Number of windings

The number of self inductances.

Inductance matrix L

The inductance matrix, in Henrys, that define the mutual coupling relationship between the self windings. It must be a N-by-N symmetrical matrix.

Resistance matrix R

The resistance matrix, in Ohms, that define the mutual coupling relationship between the self windings. It must be a N-by-N symmetrical matrix.

Mutual Inductance

Measurements

Select Winding voltages to measure the voltage across the winding terminals.

Select Winding currents to measure the current flowing through the windings.

Select Winding voltages and currents to measure the winding voltages and currents.

Place a Multimeter block in your model to display the selected measurements during the simulation.

In the **Available Measurements** list box of the Multimeter block, the measurements are identified by a label followed by the block name.

Measurement	Label
Winding voltages	Uw1:, Uw2:, Uw3:
Winding currents	Iw1:, Iw2:, Iw3:

Limitations

If you choose to model two or three windings inductances with equal mutual coupling, the following restrictions apply:

$$R_1, R_2, \dots, R_N \neq R_m$$

$$L_1, L_2, \dots, L_N \neq L_m$$

Negative values are allowed for the self- and mutual inductances as long as the self-inductances are different from the mutual inductance.

Windings can be left floating (not connected by an impedance to the rest of the circuit). However an internal resistor between the floating winding and the main circuit is automatically added. This internal connection does not affect voltage and current measurements.

Example

The power_mutual demo uses three coupled windings to inject a third harmonic voltage into a circuit fed at 60 Hz.

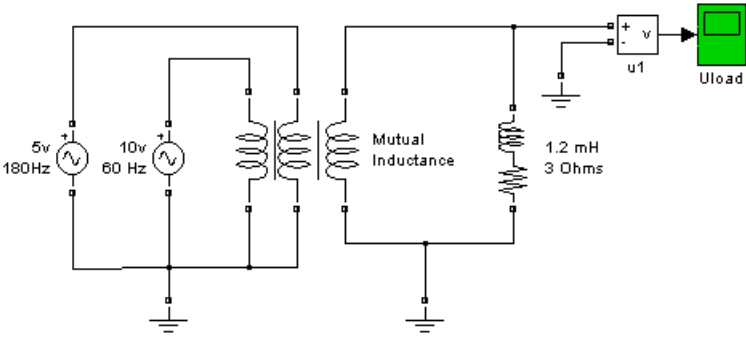

Simulation produces the following load voltage waveform:

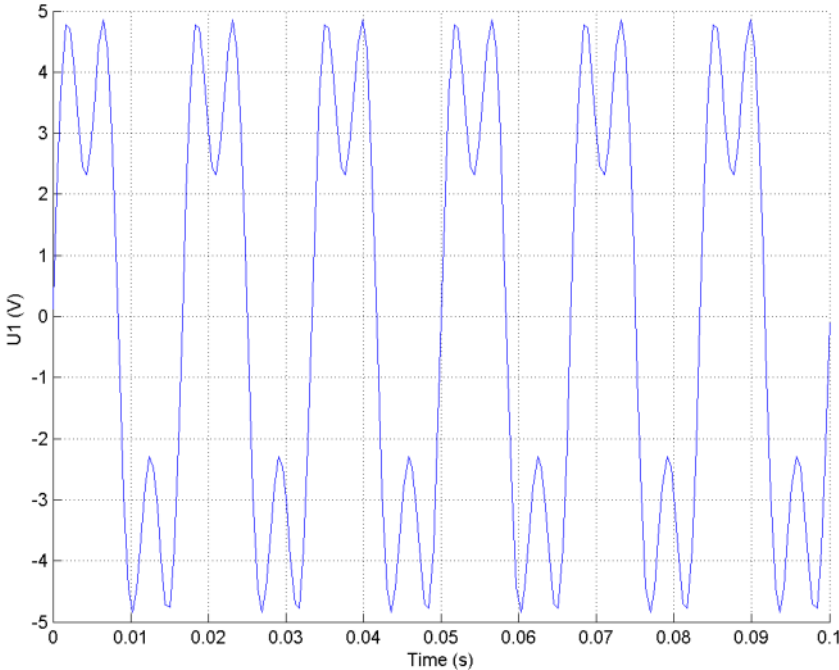

See Also

Linear Transformer, Saturable Transformer, Three-Phase Mutual Inductance Z1-Z0

Neutral

Purpose Implement a common node in the circuit

Library Elements

Description The Neutral block implements a common node with a specific node number. You can use this block to create a floating neutral or to interconnect two points without drawing a connection line.



Dialog Box and Parameters

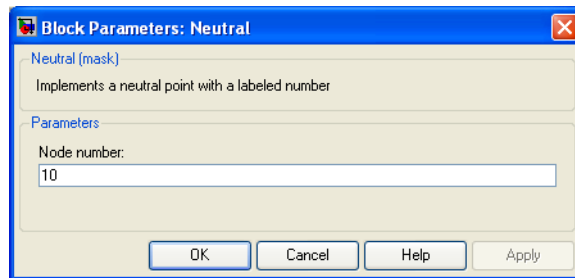

Node number

Specify a number of the neutral node. If the **Node number** parameter is set to 0, the Neutral block makes a connection to ground. The node number is displayed next to the block icon.

Example

The power_neutral demo uses three Neutral blocks. One Neutral block is used to refer a Voltage Measurement block to the ground (node 0).

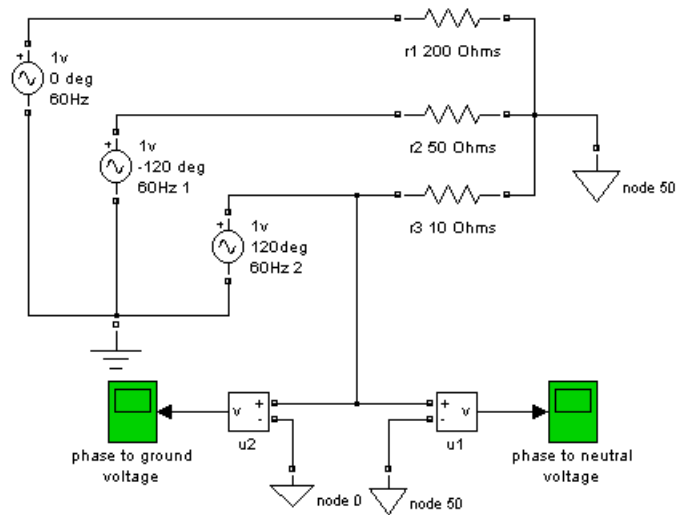

See Also

Ground

One-Quadrant Chopper DC Drive

Purpose

Implement a one-quadrant chopper (buck converter topology) DC drive

Library

Electric Drives/DC drives

Description

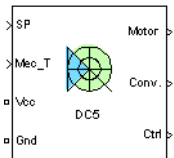

The high-level schematic shown below is built from four main blocks. The DC motor and the IGBT/Diode device (within the Universal Bridge block) are provided with the SimPowerSystems library. More details on these two blocks are available in the SimPowerSystems user guide. The two other blocks are specific to the Electric Drives library. These blocks are the speed controller and the current controller. They allow speed or torque regulation. A “regulation switch” block allows you to toggle from one type of regulation to the other. During torque regulation the speed controller is disabled. It is possible to use a simplified version of the drive containing an average-value model of the one-quadrant chopper and allowing faster simulation.

Note In SimPowerSystems, the One-Quadrant Chopper DC Drive block is commonly called the DC5 motor drive.

High-Level Schematic

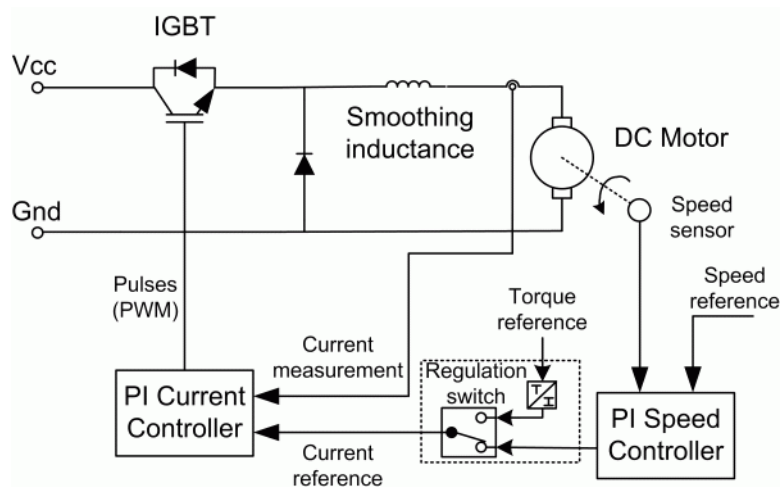

One-Quadrant Chopper DC Drive

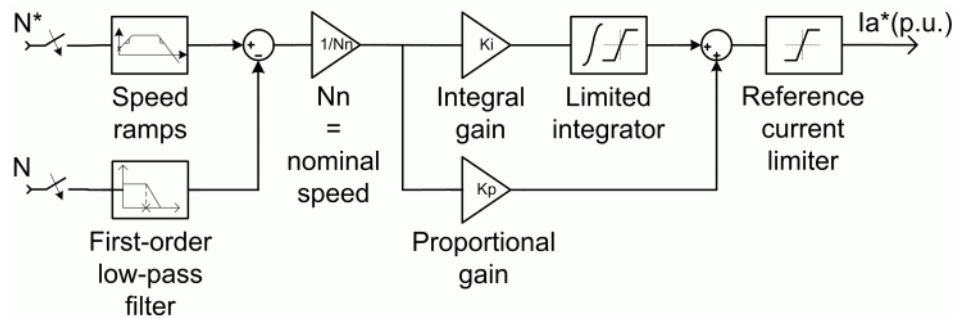

Current Controller

The armature current regulator shown below is based on a second PI controller. The regulator controls the armature current by computing the appropriate duty ratio of the IGBT fixed frequency pulses (Pulse Width Modulation). This generates the average armature voltage needed to obtain the desired armature current and thus the desired electromagnetic torque.

The controller takes the current reference (in p.u.) and the armature current flowing through the motor as inputs. The current reference is either provided by the speed controller during speed regulation or computed from the torque reference provided by the user during torque regulation. This is managed by the “regulation switch” block. The armature current input is filtered by a first-order low-pass filter.

The pulse width modulation is obtained by comparison of the PI output and a fixed frequency sawtooth carrier signal (see the figure called “Pulse Width Modulation (PWM)” on page 7-259).

One-Quadrant Chopper DC Drive

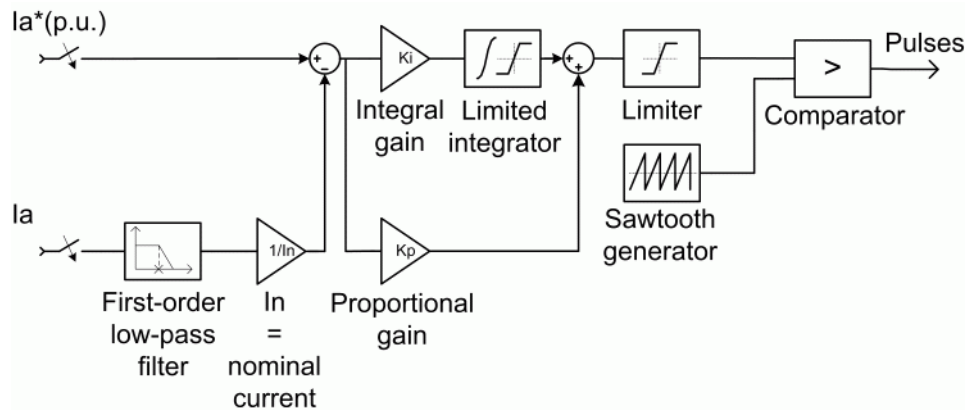

Average-Value One-Quadrant Chopper

The average-value converter is shown in the following figure.

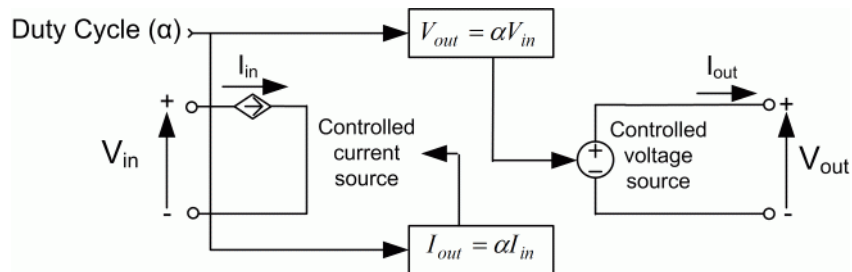

It is composed of one controlled current source on the DC source side and one controlled voltage source on the motor side. The current source allows the representation of the average input current value following the next equations:

$$I_{in} = \alpha I_{out} \text{ when } I_{out} > 0$$

$$I_{in} = I_{out} \text{ when } I_{out} \leq 0$$

with α being the firing angle value and I_{out} the armature current value. The voltage source on the motor side represents the average voltage value following the next equations :

$$V_{out} = \alpha V_{in} \text{ when } I_{out} > 0$$

One-Quadrant Chopper DC Drive

$$V_{out} = V_{in} \quad \text{when } I_{out} \leq 0$$

with V_{in} being the input voltage.

Remarks

The machine is separately excited with a constant DC field voltage source. There is thus no field voltage control. By default, the field current is set to its steady-state value when a simulation is started.

The armature voltage is provided by an IGBT buck converter controlled by two PI regulators. The buck converter is fed by a constant DC voltage source. Armature current oscillations are reduced by a smoothing inductance connected in series with the armature circuit.

The model is discrete. Good simulation results have been obtained with a $1 \mu\text{s}$ time step. In order to simulate a digital controller device, the control system has two different sampling times:

- The speed controller sampling time
- The current controller sampling time

The speed controller sampling time has to be a multiple of the current sampling time. The latter sampling time has to be a multiple of the simulation time step.

One-Quadrant Chopper DC Drive

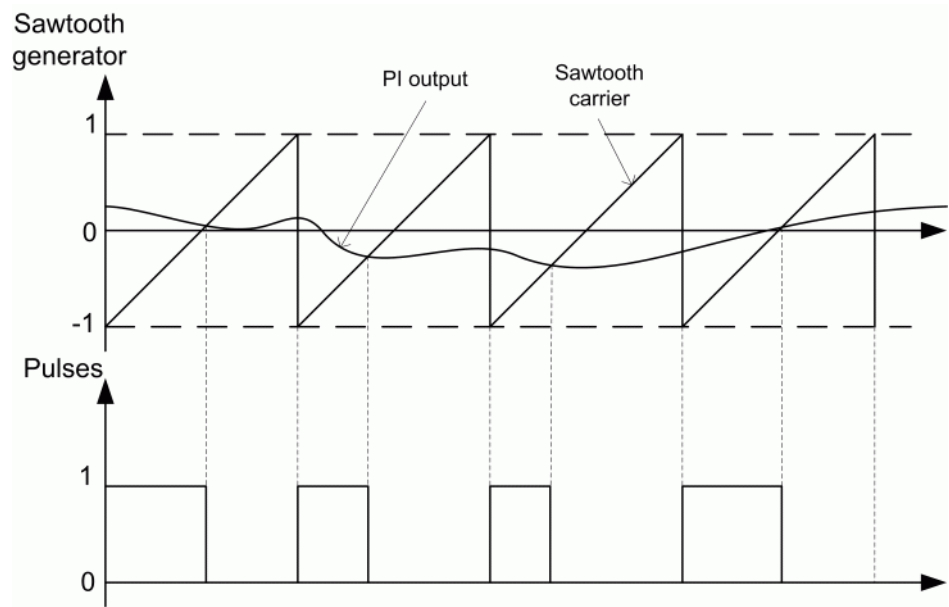

Figure 7-2: Pulse Width Modulation (PWM)

One-Quadrant Chopper DC Drive

Dialog Box

DC Machine Tab

The screenshot shows a software dialog box titled "1-Quadrant Chopper DC Motor Drive". It has three tabs: "DC Machine" (selected), "Converter", and "Controller". The "DC Machine" tab is active and contains the following parameters:

Electrical parameters

- Mutual inductance (H): 1.234
- Armature**
 - Resistance (ohm): 0.78
 - Inductance (H): 0.016
- Field**
 - Resistance (ohm): 150
 - Inductance (H): 112.5

Mechanical parameters

- Inertia (kg*m²): 0.05
- Viscous friction coefficient (N-m-s): 0.01
- Coulomb friction torque (N-m): 0
- Initial speed (rad/s): 0

At the bottom of the dialog, there is a "Model detail level" dropdown menu set to "Detailed", a "Parameters file options" section with "Load" and "Save" buttons, and a row of "OK", "Cancel", "Help", and "Apply" buttons.

The DC Machine tab displays the parameters of the DC machine block of the powerlib library. Refer to the DC Machine for more information on the DC machine block parameters.

Converter Tab

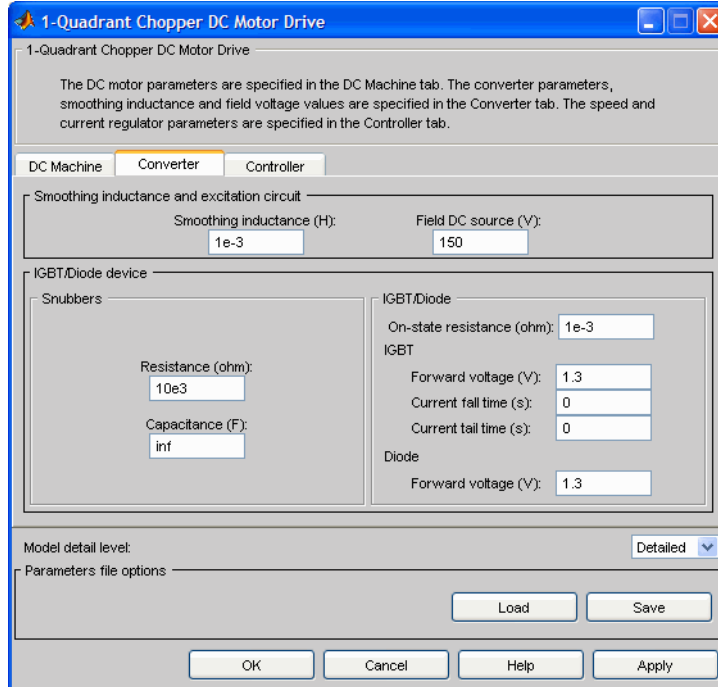

IGBT/Diode Device section

The IGBT/Diode Device section of the Converter tab displays the parameters of the Universal Bridge block of the powerlib library. Refer to the Universal Bridge for more information on the Universal Bridge block parameters.

Smoothing Inductance

The smoothing inductance value (H).

Field DC Source

The DC motor field voltage value (V).

One-Quadrant Chopper DC Drive

Controller Tab

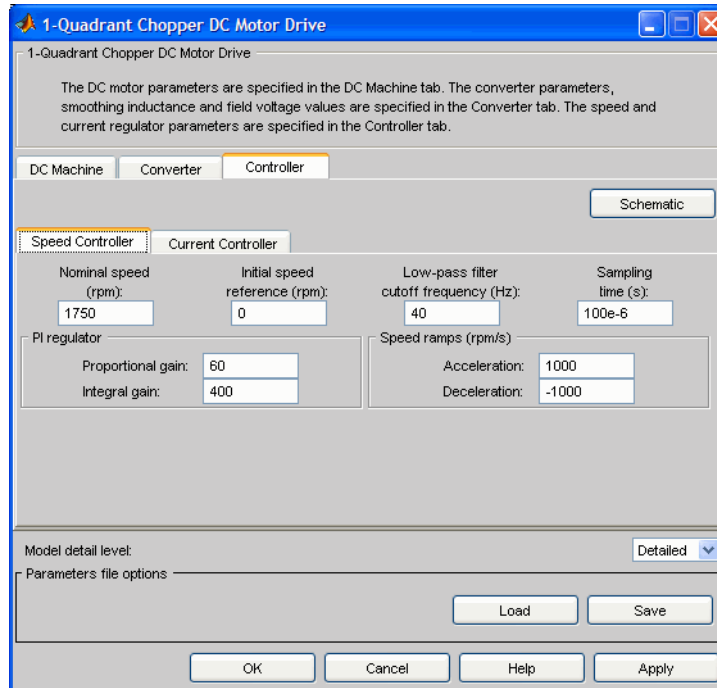

Schematic Button

When you press this button, a diagram illustrating the speed and current controllers schematics appears.

Regulation Type

This pop-up menu allows you to choose between speed and torque regulation.

Controller — Speed Controller Subtab

Nominal Speed

The nominal speed value of the DC motor (rpm). This value is used to convert motor speed from rpm to p.u. (per unit).

Initial Speed Reference

The initial speed reference value (rpm). This value allows the user to start a simulation with a speed reference other than 0 rpm.

Low-Pass Filter Cutoff Frequency

Cutoff frequency of the low-pass filter used to filter the motor speed measurement (Hz).

Sampling Time

The speed controller sampling time (s). This sampling time has to be a multiple of the current controller sampling time and of the simulation time step.

Proportional Gain

The proportional gain of the PI speed controller.

Integral Gain

The integral gain of the PI speed controller.

Acceleration

The maximum change of speed allowed during motor acceleration (rpm/s). Too great a value can cause armature over-current.

Deceleration

The maximum change of speed allowed during motor deceleration (rpm/s). Too great a value can cause armature over-current.

One-Quadrant Chopper DC Drive

Controller — Current Controller Subtab

The screenshot shows a software window titled "1-Quadrant Chopper DC Motor Drive". The window has a blue title bar and standard Windows window controls. The main content area is divided into several sections. At the top, there is a text box explaining that DC motor parameters are in the DC Machine tab, converter parameters and field voltage values are in the Converter tab, and speed and current regulator parameters are in the Controller tab. Below this, there are three tabs: "DC Machine", "Converter", and "Controller", with "Controller" being the active tab. A "Schematic" button is located to the right of the tabs. Under the "Controller" tab, there are two sub-tabs: "Speed Controller" and "Current Controller", with "Current Controller" being the active sub-tab. The "Current Controller" sub-tab contains several input fields: "Low-pass filter cutoff frequency (Hz)" with a value of 500, "Reference limit (p.u.)" with a value of 1.5, "PWM switching frequency (Hz)" with a value of 5e3, and "Sampling time (s)" with a value of 20e-6. Below these fields, there are two sections: "Nominal values" with "Power (W)" set to 5746 and "Voltage (V)" set to 240, and "PI regulator" with "Proportional gain" set to 2 and "Integral gain" set to 200. At the bottom of the window, there is a "Model detail level" dropdown menu set to "Detailed", a "Parameters file options" section with "Load" and "Save" buttons, and a row of "OK", "Cancel", "Help", and "Apply" buttons.

Low-Pass Filter Cutoff Frequency

Cutoff frequency of the low-pass filter used to filter the armature current measurement (Hz).

Reference Limit

Maximum current reference value (p.u.). 1.5 p.u. is a common value.

PWM Switching Frequency

The switching frequency of the IGBT device (Hz).

Sampling Time

The current controller sampling time (s). This sampling time has to be a submultiple of the speed controller sampling time and a multiple of the simulation time step.

Power and Voltage nominal values

The DC motor nominal power (W) and voltage (V) values. These values are used to convert armature current from amperes to p.u. (per unit).

Proportional Gain

The proportional gain of the PI current controller.

Integral Gain

The integral gain of the PI current controller.

Block Inputs and Outputs

SP

The speed or torque set point. Note that the speed set point can be a step function, but the speed change rate will follow the acceleration / deceleration ramps.

Mec_T

The mechanical load torque input. If the load torque and the speed have opposite signs, the accelerating torque will be the sum of the electromagnetic and load torques.

Vcc, Gnd

The DC voltage source electric connections. The voltage must be adequate for the motor size.

Motor

The motor measurement vector. This vector is composed of two elements:

- The armature voltage
- The DC motor measurement vector (containing the speed, armature current, field current, and electromagnetic torque values). Note that the speed signal is converted from rad/s to rpm before output.

Conv

The IGBT/Diode device measurement vector. This vector includes the converter output voltage. The output current is not included since it is equal to the DC motor armature current. Note that all current and voltage values of the converter can be visualized with the Multimeter block.

Ctrl

The controller measurement vector. This vector contains:

- The armature current reference

One-Quadrant Chopper DC Drive

- The duty cycle of the PWM pulses
- The speed or torque error (difference between the speed reference ramp and actual speed or between the torque reference and actual torque)
- The speed reference ramp or torque reference

Model Specifications

The library contains a 5 hp drive parameter set. The specifications of the 5 hp drive are shown in the following table.

5 HP Drive Specifications

Drive Input Voltage		
	Amplitude	280 V
Motor Nominal Values		
	Power	5 hp
	Speed	1750 rpm
	Voltage	240 V

Example

The dc5_example demo illustrates the one-quadrant chopper drive used with the 5 hp drive parameter set during speed regulation.

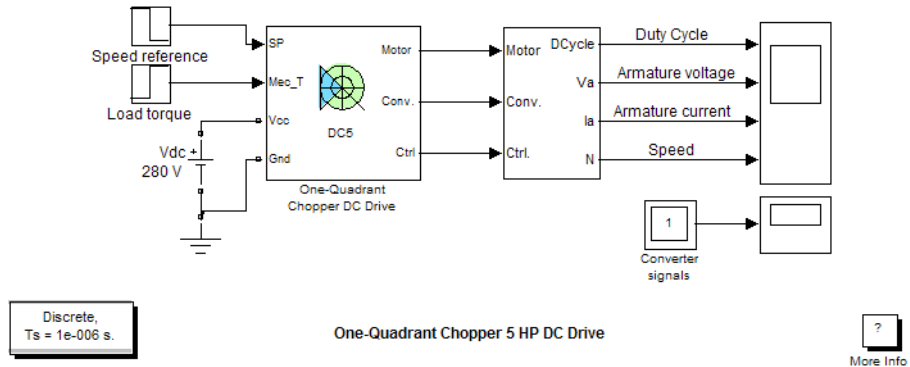

One-Quadrant Chopper DC Drive

The buck converter is fed by a 280 V DC voltage source and the IGBT switching frequency is 5 kHz.

The speed reference is set at 500 rpm at $t = 0$ s. Initial load torque is 15 N.m.

Observe that the motor speed follows the reference ramp accurately (+250 rpm/s) and reaches steady state around $t = 2.5$ s.

The armature current follows the current reference very well, with fast response time and small ripples. Notice that the current ripple frequency is 5 kHz.

At $t = 2.5$ s, the load torque passes from 15 N.m to 20 N.m. The motor speed recovers fast and is back at 500 rpm at $t = 3$ s. The current reference rises to about 16.7 A to generate a higher electromagnetic torque to maintain the speed reference. As observed before, the armature current follows its reference perfectly.

At $t = 3$ s, the speed reference jumps down to 350 rpm. The armature current lowers in order for the speed to decrease following the negative speed slope (-250 rpm/s) with the help of the load torque.

At $t = 4$ s, the speed stabilizes around its reference.

The following figure shows the armature current and speed waveforms.

One-Quadrant Chopper DC Drive

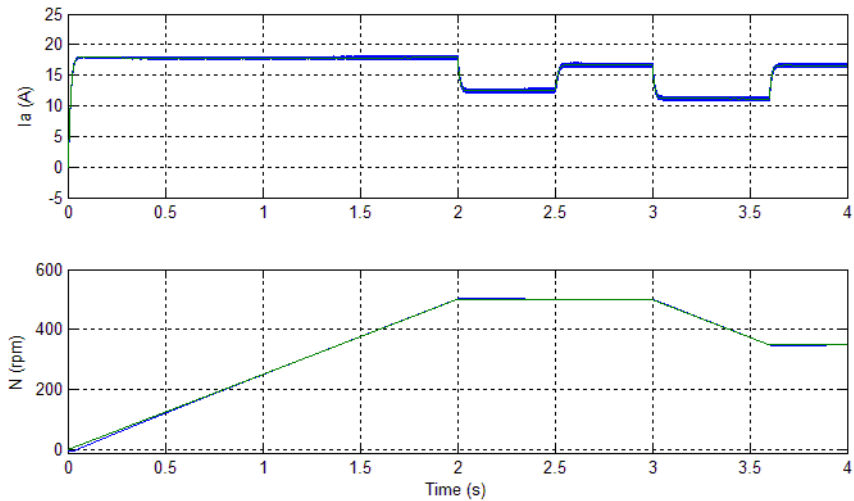

DC5 Example – Current and Speed Waveforms

The next figure shows the duty cycle of the chopper pulses and the corresponding armature voltage and current waveforms during a time interval of 2 ms.

Purpose Implement a parallel RLC branch

Library Elements

Description The Parallel RLC Branch block implements a single resistor, inductor, and capacitor or a parallel combination of these. Only existing elements are displayed in the block icon.



Negative values are allowed for resistance, inductance, and capacitance.

Dialog Box and Parameters

Block Parameters: Parallel RLC Branch

Parallel RLC Branch (mask)
Implements a parallel branch of RLC elements.
Use the 'Branch type' parameter to add or remove elements from the branch.

Parameters

Branch type: RLC

Resistance R (Ohms):
1

Inductance L (H):
1e-3

Set the initial inductor current
Inductor initial current (A):
0

Capacitance C (F):
1e-6

Set the initial capacitor voltage
Capacitor initial voltage (V):
0

Measurements: None

OK Cancel Help Apply

Branch type

Select the elements you want to include in the branch. The **R** letter defines the resistor, the **L** letter defines the inductor, and the **C** letter defines the capacitor.

Parallel RLC Branch

Resistance

The branch resistance, in ohms (Ω). The **Resistance** parameter is not visible if the resistor element is not specified in the **Branch type** parameter.

Inductance L

The branch inductance, in henries (H). The **Inductance** parameter is not visible if the inductor element is not specified in the **Branch type** parameter.

Set the initial inductor current

If selected, the initial inductor current is defined by the **Inductor initial current** parameter. If not selected, SimPowerSystems calculates the initial inductor current in order to start the simulation steady-state.

The **Set the initial inductor current** parameter is not visible and have no effect on the block if the inductor element is not specified in the **Branch type** parameter.

Inductor initial current (A)

The initial inductor current used at the start of the simulation. The **Inductor initial current** parameter is not visible and have no effect on the block if the inductor is not modeled and if the **Set the initial inductor current** parameter is not selected.

Capacitance C

The branch capacitance, in farads (F). The **Capacitance** parameter is not visible if the capacitance element is not specified in the **Branch type** parameter.

Set the initial capacitor voltage

If selected, the initial capacitor voltage is defined by the **Capacitor initial voltage** parameter. If not selected, SimPowerSystems calculates the initial capacitor voltage in order to start the simulation in steady-state.

The **Set the initial capacitor voltage** parameter is not visible and have no effect on the block if the capacitor element is not specified in the **Branch type** parameter.

Capacitor initial voltage (V)

The initial capacitor voltage used at the start of the simulation. The **Capacitor initial voltage** parameter is not visible and have no effect on the block if the capacitor is not modeled and if the **Set the initial capacitor voltage** parameter is not selected.

Measurements

Select Branch voltage to measure the voltage across the Parallel RLC Branch block terminals.

Select Branch current to measure the total current (sum of R, L, C currents) flowing through the Parallel RLC Branch block.

Select Branch voltage and current to measure the voltage and the current of the Parallel RLC Branch block.

Place a Multimeter block in your model to display the selected measurements during the simulation. In the **Available Measurements** list box of the Multimeter block, the measurement is identified by a label followed by the block name.

Measurement	Label
Branch voltage	Ub:
Branch current	Ib:

Example

The power_parallelbranch demo is used to obtain the frequency response of an eleventh-harmonic filter (tuned frequency at 660 Hz) connected on a 60 Hz power system:

Parallel RLC Branch

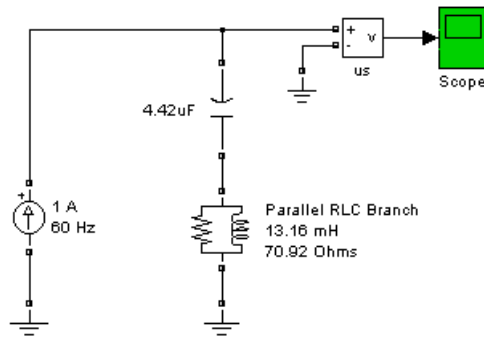

The network impedance in the Laplace domain is

$$Z(s) = \frac{V(s)}{I(s)} = \frac{RLCs^2 + Ls + R}{LCs^2 + RCs}$$

To obtain the frequency response of the impedance you have to get the state-space model (A B C D matrices) of the system.

This system is a one input (Is) and one output (Vs) system.

Note If you have the Control System Toolbox installed, you can get the transfer function $Z(s)$ from the state-space matrices and the bode function.

```
[A,B,C,D] = power_analyze('power_paralbranch');  
freq = logspace(1,4,500);  
w = 2*pi*freq;  
[Zmag,Zphase] = bode(A,B,C,D,1,w);  
subplot(2,1,1)  
loglog(freq,Zmag)  
grid  
title('11th harmonic filter')  
xlabel('Frequency, Hz')  
ylabel('Impedance Z')  
subplot(2,1,2)  
semilogx(freq,Zphase)  
xlabel('Frequency, Hz')
```

```
ylabel('phase Z')  
grid
```

You can also use the Impedance Measurement block and the Powergui block to plot the impedance as a function of frequency.

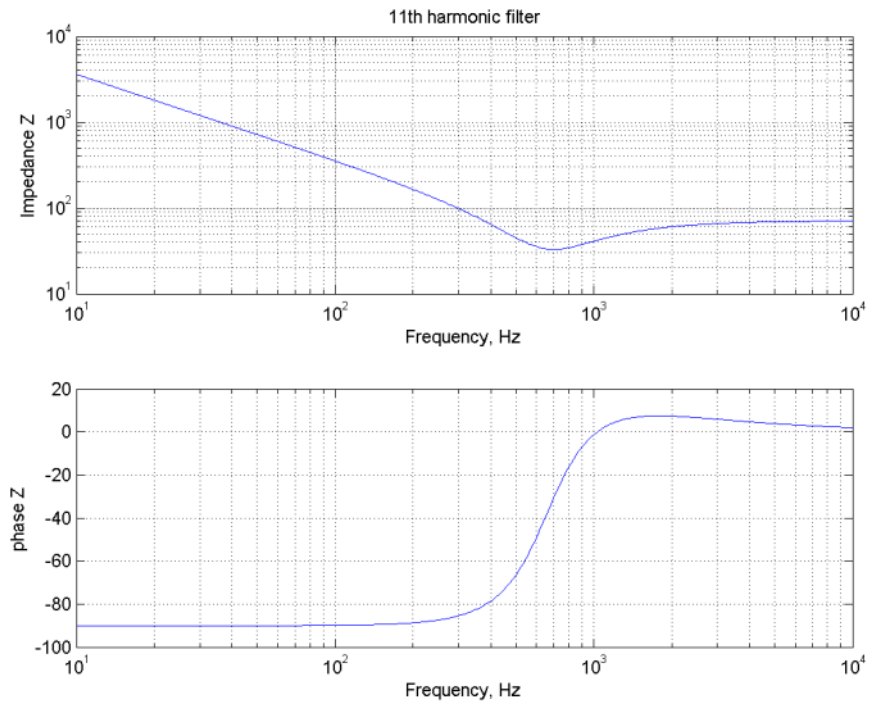

See Also

Multimeter, Parallel RLC Load, Powergui, Series RLC Branch, Series RLC Load

Parallel RLC Load

Purpose Implement a linear parallel RLC load

Library Elements

Description



The Parallel RLC Load block implements a linear load as a parallel combination of RLC elements. At the specified frequency, the load exhibits a constant impedance. The active and reactive powers absorbed by the load are proportional to the square of the applied voltage.

Only elements associated with nonzero powers are displayed in the block icon.

Dialog Box and Parameters

Block Parameters: Parallel RLC Load

Parallel RLC Load (mask)
Implements a parallel RLC load.

Parameters

Nominal voltage V_n (Vrms):
1000

Nominal frequency f_n (Hz):
60

Active power P (W):
10e3

Inductive reactive Power Q_L (positive var):
100

Capacitive reactive power Q_c (negative var):
100

Set the initial capacitor voltage
Capacitor initial voltage (V):
0

Set the initial inductor current
Inductor initial current (A):
0

Measurements: None

OK Cancel Help Apply

Nominal voltage V_n

The nominal voltage of the load, in volts RMS (Vrms).

Nominal frequency f_n

The nominal frequency, in hertz (Hz).

Active power P

The active power of the load, in watts.

Inductive reactive power QL

The inductive reactive power QL, in vars. Specify a positive value, or 0.

Capacitive reactive power QC

The capacitive reactive power QC, in vars. Specify a positive value, or 0.

Set the initial capacitor voltage

If selected, the initial capacitor voltage is defined by the **Capacitor initial voltage** parameter. If not selected, SimPowerSystems calculates the initial capacitor voltage in order to start the simulation in steady-state.

The **Set the initial capacitor voltage** parameter have no effect on the block if the capacitive reactive power is equal to zero.

Capacitor initial voltage (V)

The initial capacitor voltage used at the start of the simulation. The **Capacitor initial voltage** parameter have no effect on the block if the capacitive reactive power is equal to zero and if the **Set the initial capacitor voltage** parameter is not selected.

Set the initial inductor current

If selected, the initial inductor current is defined by the **Inductor initial current** parameter. If not selected, SimPowerSystems calculates the initial inductor current in order to start the simulation steady-state.

The **Set the initial inductor current** parameter have no effect on the block if the inductive reactive power is equal to zero.

Inductor initial current (A)

The initial inductor current used at the start of the simulation. The **Inductor initial current** parameter have no effect on the block if the inductive reactive power is equal to zero and if the **Set the initial inductor current** parameter is not selected.

Measurements

Select **Branch voltage** to measure the voltage across the Parallel RLC Load block terminals.

Parallel RLC Load

Select **Branch current** to measure the current flowing through the Parallel RLC Load block.

Select **Branch voltage and current** to measure the voltage and the current of the Parallel RLC Load block.

Place a Multimeter block in your model to display the selected measurements during the simulation. In the **Available Measurements** list box of the Multimeter block, the measurement is identified by a label followed by the block name.

Measurement	Label
Branch voltage	Ub :
Branch current	Ib :

Example

The power_parallelload demo uses a parallel RLC load block to implement a load.

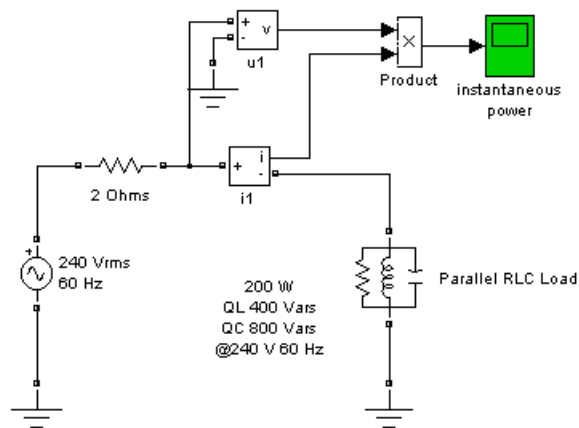

See Also

Multimeter, Parallel RLC Branch, Series RLC Branch, Series RLC Load

Permanent Magnet Synchronous Machine

Purpose

Model the dynamics of a three-phase permanent magnet synchronous machine with sinusoidal flux distribution, or trapezoidal flux distribution.

Library

Machines

Description

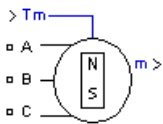

The Permanent Magnet Synchronous Machine block operates in either generator or motor mode. The mode of operation is dictated by the sign of the mechanical torque (positive for motor mode, negative for generator mode). The electrical and mechanical parts of the machine are each represented by a second-order state-space model. The sinusoidal model assumes that the flux established by the permanent magnets in the stator is sinusoidal, which implies that the electromotive forces are sinusoidal. For the trapezoidal machine, the model assumes that the flux established by the permanent magnets is purely trapezoidal, which implies a trapezoidal electromotive forces waveform.

The block implements the following equations.

Sinusoidal Model Electrical System

These equations are expressed in the rotor reference frame (qd frame).

$$\frac{d}{dt}i_d = \frac{1}{L_d}v_d - \frac{R}{L_d}i_d + \frac{L_q}{L_d}p\omega_r i_q$$

$$\frac{d}{dt}i_q = \frac{1}{L_q}v_q - \frac{R}{L_q}i_q - \frac{L_d}{L_q}p\omega_r i_d - \frac{\lambda p\omega_r}{L_q}$$

$$T_e = 1.5p[\lambda i_q + (L_d - L_q)i_d i_q]$$

Permanent Magnet Synchronous Machine

where (all quantities in the rotor reference frame are referred to the stator)

L_q, L_d	q and d axis inductances
R	Resistance of the stator windings
i_q, i_d	q and d axis currents
v_q, v_d	q and d axis voltages
ω_r	Angular velocity of the rotor
λ	Amplitude of the flux induced by the permanent magnets of the rotor in the stator phases
p	Number of pole pairs
T_e	Electromagnetic torque

Trapezoidal Model Electrical System

These equations are expressed in the phase reference frame (abc frame).

$$\frac{d}{dt}i_a = \frac{1}{3L_s}[2v_{ab} + v_{bc} - 3R_s i_a + \lambda p \omega_r (-2\Phi'_a + \Phi'_b + \Phi'_c)]$$

$$\frac{d}{dt}i_b = \frac{1}{3L_s}[-v_{ab} + v_{bc} - 3R_s i_b + \lambda p \omega_r (\Phi'_a - 2\Phi'_b + \Phi'_c)]$$

$$\frac{d}{dt}i_c = -\left(\frac{d}{dt}i_a + \frac{d}{dt}i_b\right)$$

$$T_e = p\lambda(\Phi'_a \cdot i_a + \Phi'_b \cdot i_b + \Phi'_c \cdot i_c)$$

Permanent Magnet Synchronous Machine

where the electromotive force Φ' is represented by

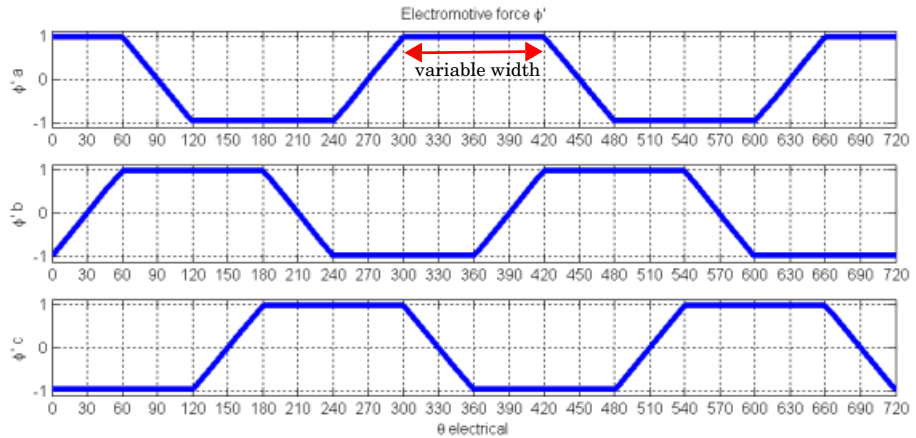

and

L_s Inductance of the stator windings

R Resistance of the stator windings

i_a, i_b, i_c a, b and c phase currents

$\Phi'_a, \Phi'_b, \Phi'_c$ a, b and c phase electromotive forces

v_{ab}, v_{bc} ab and bc phase to phase voltages

ω_r Angular velocity of the rotor

λ Amplitude of the flux induced by the permanent magnets of the rotor in the stator phases

p Number of pole pairs

T_e Electromagnetic torque

Mechanical System (for both models)

$$\frac{d}{dt}\omega_r = \frac{1}{J}(T_e - F\omega_r - T_m)$$

$$\frac{d\theta}{dt} = \omega_r$$

Permanent Magnet Synchronous Machine

where

J	Combined inertia of rotor and load
F	Combined viscous friction of rotor and load
θ	Rotor angular position
T_m	Shaft mechanical torque

Dialog Box and Parameters

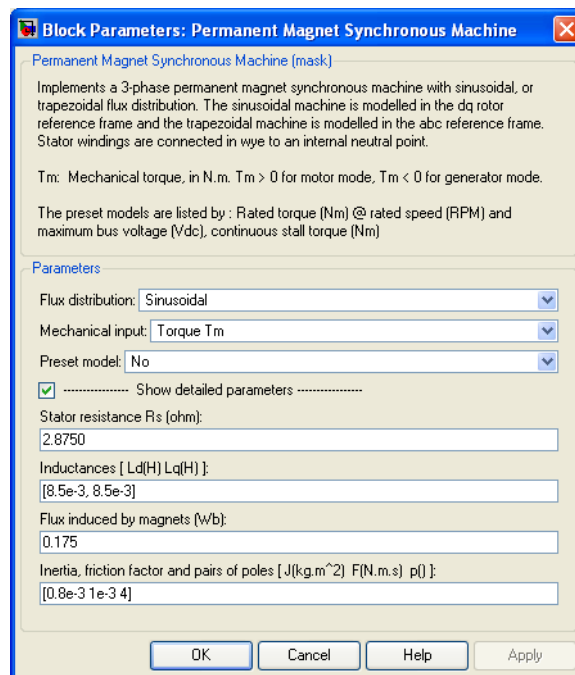

Flux distribution

Allows to select between the sinusoidal and the trapezoidal electromotive force.

Mechanical input

Allows you to select either the torque applied to the shaft or the rotor speed as the Simulink signal applied to the block's input.

Permanent Magnet Synchronous Machine

Select **Torque Tm** to specify a torque input, in N.m., and change labeling of the block's input to Tm. The machine speed is determined by the machine Inertia J and by the difference between the applied mechanical torque Tm and the internal electromagnetic torque Te. The sign convention for the mechanical torque is the following: when the speed is positive, a positive torque signal indicates motor mode and a negative signal indicates generator mode.

Select **Speed w** to specify a speed input, in rad/s, and change labeling of the block's input to w. The machine speed is imposed and the mechanical part of the model (Inertia J) is ignored. Using the speed as the mechanical input allows modeling a mechanical coupling between two machines and interfacing with SimMechanics and SimDriveline.

The next figure indicates how to model a stiff shaft interconnection in a motor-generator. The speed output of machine 1 (motor) is connected to the speed input of machine 2 (generator), while machine 2 electromagnetic torque output Te is applied to the mechanical torque input Tm of machine 1. The Kw factor takes into account speed units of both machines (pu or rad/s) and gear box ratio. The KT factor takes into account torque units of both machines (pu or N.m) and machine ratings. Also, as the inertia J2 is ignored in machine 2, J2 referred to machine 1 speed must be added to machine 1 inertia J1.

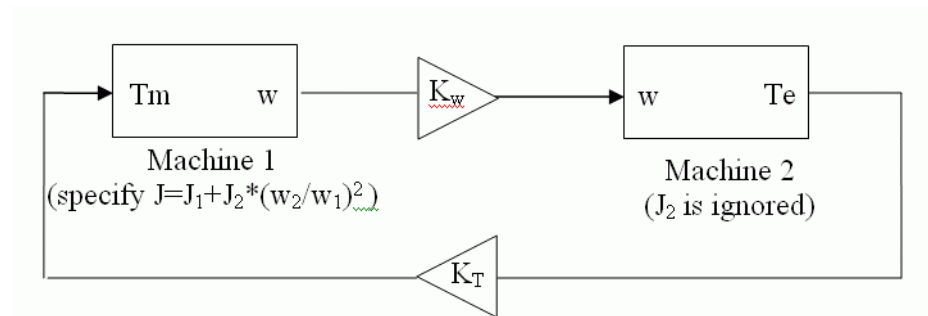

Preset Model

Provides a set of predetermined electrical and mechanical parameters for various permanent magnet synchronous motor ratings of torque (N.m), DC bus voltage (V), rated speed (rpm), and continuous stall torque (N.m) .

Permanent Magnet Synchronous Machine

Select one of the preset models to load the corresponding electrical and mechanical parameters in the entries of the dialog box. Select No if you don't want to use a preset model.

Select **Show detailed parameters** to view and edit the detailed parameters associated with the preset model.

Show detailed parameters

If selected, the mask displays the detailed parameters of the Permanent Magnet Synchronous Machine block. The detailed parameters can be modified no matter the preset model you selected in the **Preset model** list.

Stator resistance

The stator resistance R_s (Ω).

Stator inductances

- Sinusoidal model: The d-axis and q-axis stator inductances L_d (H) and L_q (H)
- Trapezoidal model: The stator inductance L_s (H)

Flux induced by magnets

The constant flux λ (Wb) induced in the stator windings by the magnets.

Back EMF flat top area

The width of the flat top for a half period of the electromotive force Φ' (degrees) (only for trapezoidal machine).

Inertia, friction factor and pairs of poles

The combined machine and load inertia coefficient J ($\text{kg}\cdot\text{m}^2$), combined viscous friction coefficient F ($\text{N}\cdot\text{m}\cdot\text{s}$), and pole pairs p .

Inputs and Outputs

T_m

The Simulink input is the mechanical torque at the machine's shaft. This input should normally be positive because the Permanent Magnet Synchronous Machine block is usually used as a motor. Nevertheless, you can apply a negative torque input if you choose to use the block in generator mode.

m

The Simulink output of the block is a vector containing 13 signals for the sinusoidal model and 12 signals for the trapezoidal model. You can

Permanent Magnet Synchronous Machine

demultiplex these signals by using the Bus Selector block provided in the Simulink library.

Definition	Units	Symbol	Signal number	
			Sinusoidal model	Trapezoidal model
Stator current i_{s_a}	A	i_a	1	1
Stator current i_{s_b}	A	i_b	2	2
Stator current i_{s_c}	A	i_c	3	3
Stator current i_{s_q}	A	i_q	4	N/A
Stator current i_{s_d}	A	i_d	5	N/A
Stator voltage V_{s_q}	V	v_q	6	N/A
Stator voltage V_{s_d}	V	v_d	7	N/A
Phase back EMF e_a	V	e_a	N/A	4
Phase back EMF e_b	V	e_b	N/A	5
Phase back EMF e_c	V	e_c	N/A	6
Hall effect signal h_a^*	logic 0-1	h_a	8	7
Hall effect signal h_b^*	logic 0-1	h_b	9	8
Hall effect signal h_c^*	logic 0-1	h_c	10	9
Rotor speed ω_m	rad/s	ω_r	11	10
Rotor angle θ_{tam}	rad	θ_r	12	11
Electromagnetic torque T_e	N.m	T_e	13	12

The Hall effect signal provides a logical indication of the back EMF positioning. This signal is very useful to control directly the power switches. There is a change of state at each zero crossing of the phase to phase voltage. These signals must be decoded before being applied to the switches.

Permanent Magnet Synchronous Machine

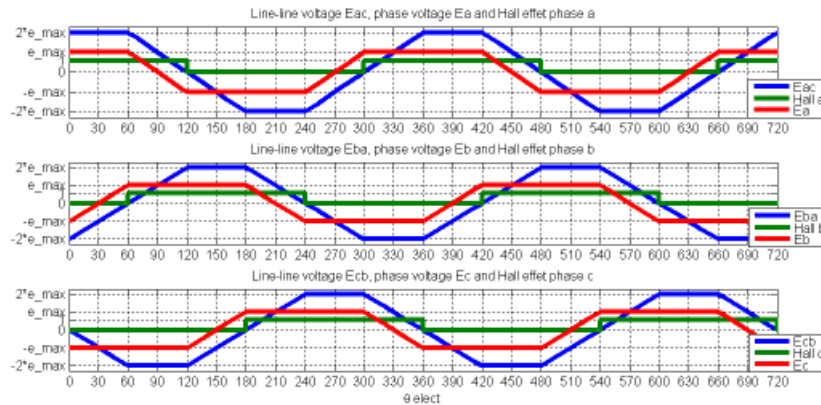

Assumption

The Permanent Magnet Synchronous Machine block assumes a linear magnetic circuit with no saturation of the stator and rotor iron. This assumption can be made because of the large air gap usually found in permanent magnet synchronous machines.

Limitations

When you use Permanent Magnet Synchronous Machine blocks in discrete systems, you might have to use a small parasitic resistive load, connected at the machine terminals, in order to avoid numerical oscillations. Large sample times require larger loads. The minimum resistive load is proportional to the sample time. As a rule of thumb, remember that with a 25 ms time step on a 60 Hz system, the minimum load is approximately 2.5% of the machine nominal power. For example, a 200 MVA PM synchronous machine in a power system discretized with a 50 ms sample time requires approximately 5% of resistive load or 10 MW. If the sample time is reduced to 20 ms, a resistive load of 4 MW should be sufficient.

Example

The power_brushlessDCmotor demo illustrates the use of the Permanent Magnet Synchronous Machine block in motoring mode with a closed-loop control system built entirely with Simulink blocks. The complete system includes a six step inverter block from the SimPowerSystems library. Two control loops are used; the inner loop synchronizes the pulses of the bridge with the electromotive forces, and the outer loop regulates the motor's speed, by varying the DC bus voltage. The mechanical torque applied at the motor's shaft

Permanent Magnet Synchronous Machine

is originally 0 N.m (no load) and steps to its nominal value (3 N.m) at $t = 0.1$ second. The parameters of the machine are found in the dialog box section.

Brushless DC motor fed by six step inverter

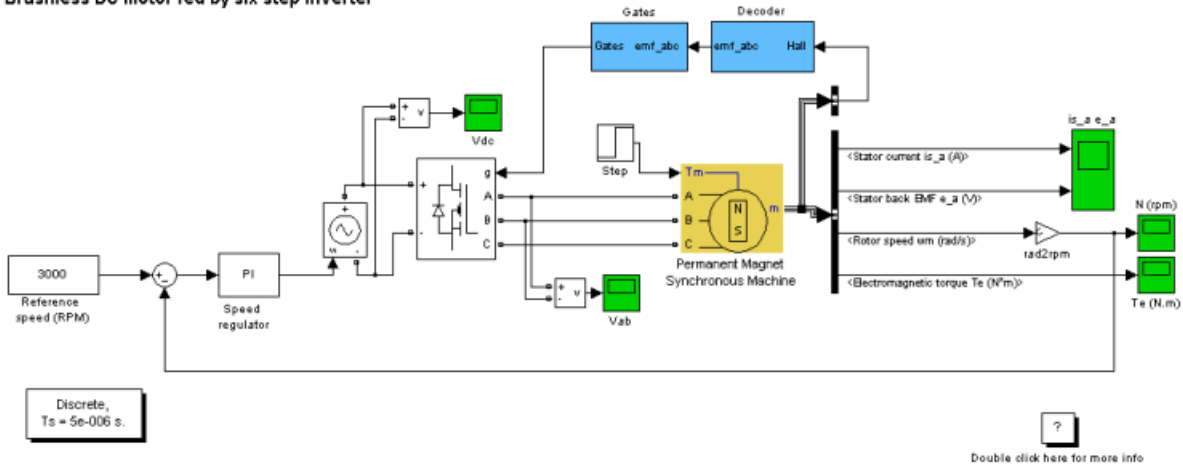

Set the simulation parameters as follows:

- Type: Fixed-step
- Integrator type: Runge-Kutta, ode4
- Sample time: 5e-6 (set automatically by the “Model properties”)
- Stop time: 0.2

Set the **Flux distribution** parameter to Trapezoidal and run the simulation to observe the motor's torque, speed, and currents. Change the **Back EMF flat top area parameter** of the trapezoidal model from 120 to 0 and observe the waveform of the electromotive force e_a .

Permanent Magnet Synchronous Machine

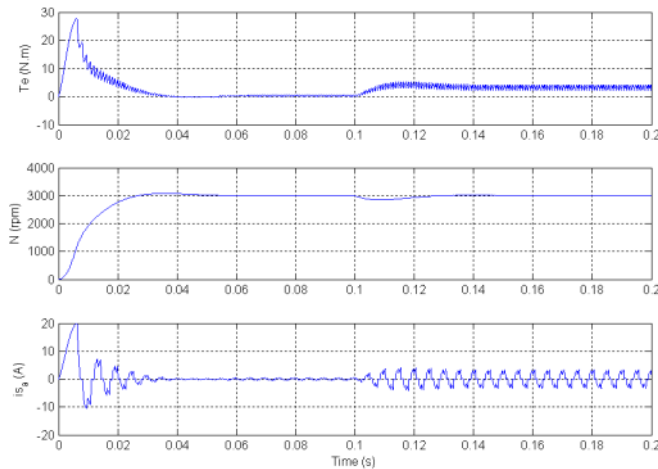

The torque climbs to nearly 28 N.m when the motor starts and stabilizes rapidly when the motor reaches the reference value. The nominal torque is applied at $t = 0.1$ second and the controller reacts rapidly and increases the DC bus voltage to produce the required electric torque. Observe the saw tooth shape of the currents waveforms. This is caused by the six step controller, which applies a constant voltage value during 120 electrical degrees to the motor. The initial current is high and decreases during the acceleration to the nominal speed. When the nominal torque is applied, the stator current increases to maintain the nominal speed. The saw tooth waveform is also observed in the electromotive torque signal T_e . However, the motor's inertia prevents this noise from appearing in the motor's speed waveform.

When the **Back EMF flat top area** parameter of the trapezoidal model is changed from 120 to 0, the model reacts exactly like the sinusoidal model. The electromotive force e_a is purely sinusoidal and the torque ripple is less than the previous case. The sinusoidal model requires a larger current to produce the same torque. That's why the trapezoidal machine is used in high torque applications, and the sinusoidal machine in precision applications.

Permanent Magnet Synchronous Machine

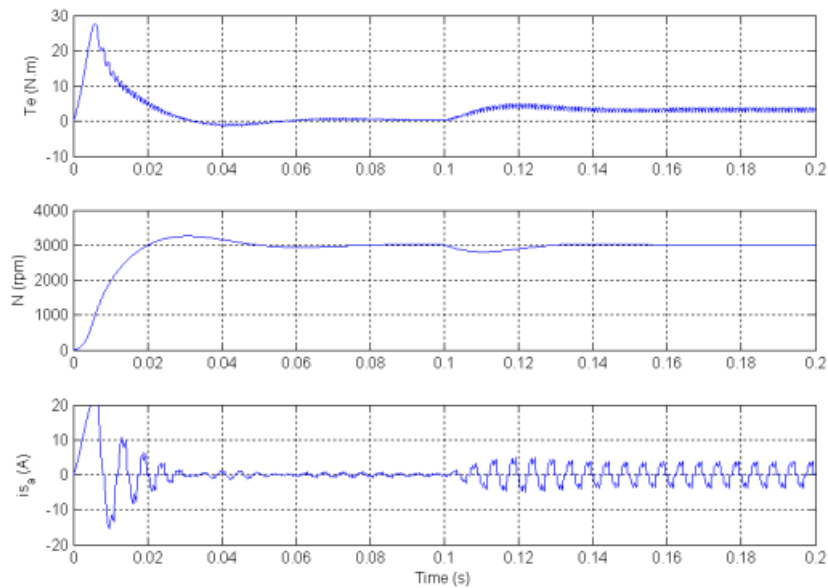

References

- [1] Grenier, D., L.-A. Dessaint, O. Akhrif, Y. Bonnassieux, and B. LePioufle, "Experimental Nonlinear Torque Control of a Permanent Magnet Synchronous Motor Using Saliency," *IEEE Transactions on Industrial Electronics*, Vol. 44, No. 5, October 1997, pp. 680-687.

PI Section Line

Purpose Implement a single-phase transmission line with lumped parameters

Library Elements

Description The PI Section Line block implements a single-phase transmission line with parameters lumped in PI sections.

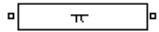

For a transmission line, the resistance, inductance, and capacitance are uniformly distributed along the line. An approximate model of the distributed parameter line is obtained by cascading several identical PI sections, as shown in the following figure.

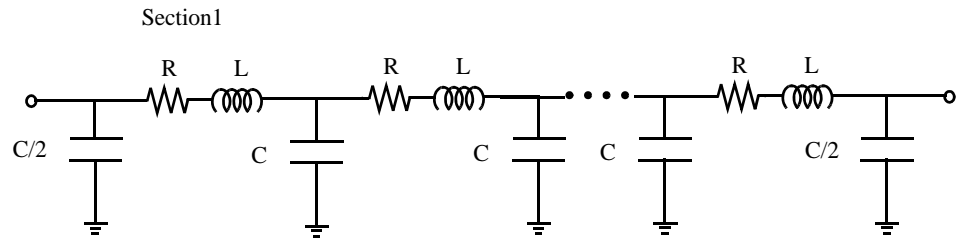

Unlike the Distributed Parameter Line block, which has an infinite number of states, the PI section linear model has a finite number of states that permit you to compute a linear state-space model. The number of sections to be used depends on the frequency range to be represented.

A good approximation of the maximum frequency range represented by the PI line model is given by the following equation:

$$f_{max} = \frac{Nv}{8l}$$

where

N Number of PI sections

v Propagation speed in km/s = $1/\sqrt{LC}$ L in H/km, C in F/km

l Line length in km

For example, for a 100 km aerial line having a propagation speed of 300,000 km/s, the maximum frequency range represented with a single PI section is

approximately 375 Hz. For studying interactions between a power system and a control system, this simple model could be sufficient. However for switching surge studies involving high-frequency transients in the kHz range, much shorter PI sections should be used. In fact, you can obtain the most accurate results by using a distributed parameters line model.

Note The Powergui block provides a graphical tool for the calculation of the resistance, inductance, and capacitance per unit length based on the line geometry and the conductor characteristics.

Dialog Box and Parameters

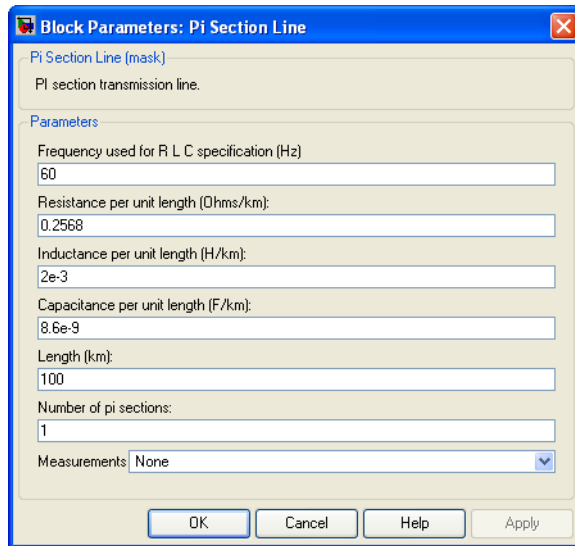

Frequency used for RLC specifications

Frequency used to compute the line parameters, in hertz (Hz).

Resistance per unit length

The resistance per unit length of the line, in ohms/km (Ω).

Inductance per unit length

The inductance per unit length of the line, in henries/km (H/km).

PI Section Line

Capacitance per unit length

The capacitance per unit length of the line, in farads/km (F/km).

Length

The line length in km.

Number of pi sections

The number of PI sections. The minimum value is 1.

Measurements

Select Input and output voltages to measure the sending end (input port) and receiving end (output port) voltages of the line model.

Select Input and output voltages to measure the sending end and receiving end currents of the line model.

Select All voltages and currents to measure the sending end and receiving end voltages and currents of the line model.

Place a Multimeter block in your model to display the selected measurements during the simulation. In the **Available Measurements** list box of the Multimeter block, the measurement is identified by a label followed by the block name.

Measurement	Label
Sending end voltage (block input)	Us:
Receiving end voltage (block output)	Ur:
Sending end current (input current)	Is:
Receiving end current (output current)	Ir:

Example

The power_piline demo shows the line energization voltages and currents of a PI section line.

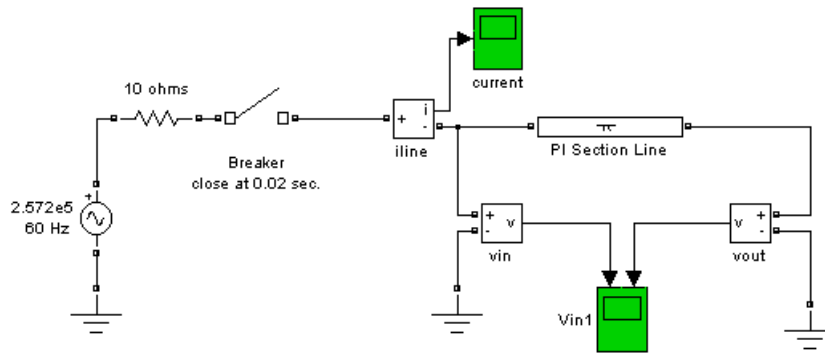

The results obtained with the line modeled by one PI section of 100 km and 10 PI sections of 10 km are shown.

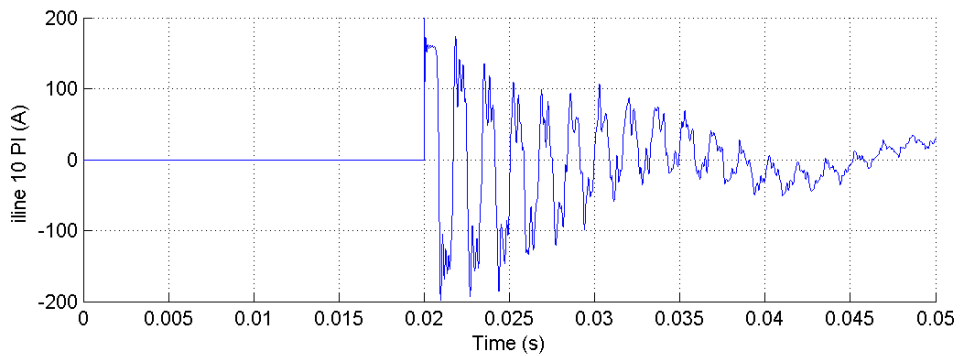
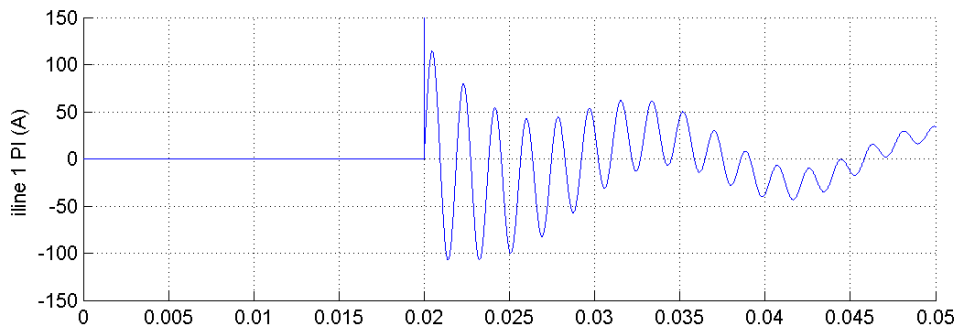

See Also

Distributed Parameter Line

PM Synchronous Motor Drive

Purpose

Implement a Permanent Magnet Synchronous Motor (PMSM) vector control drive

Library

Electric Drives/AC drives

Description

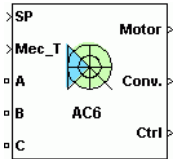

The high-level schematic shown below is built from six main blocks. The PMSM motor, the three-phase inverter, and the three-phase diode rectifier models are provided with the SimPowerSystems library. More details on these three blocks are available in the SimPowerSystems user guide. The speed controller, the braking chopper, and the vector controller models are specific to the drive library. It is possible to use a simplified version of the drive containing an average-value model of the inverter for faster simulation.

Note In SimPowerSystems, the PM Synchronous Motor Drive block is commonly called the AC6 motor drive.

High-Level Schematic

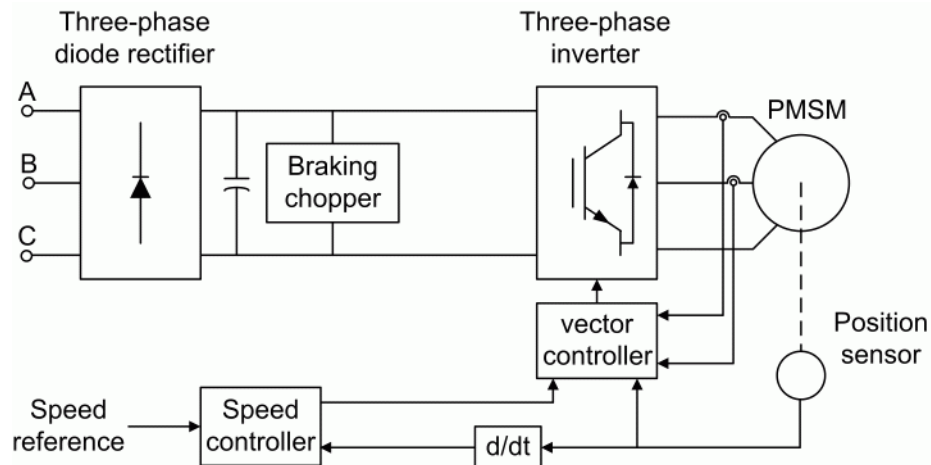

PM Synchronous Motor Drive

Simulink Schematic

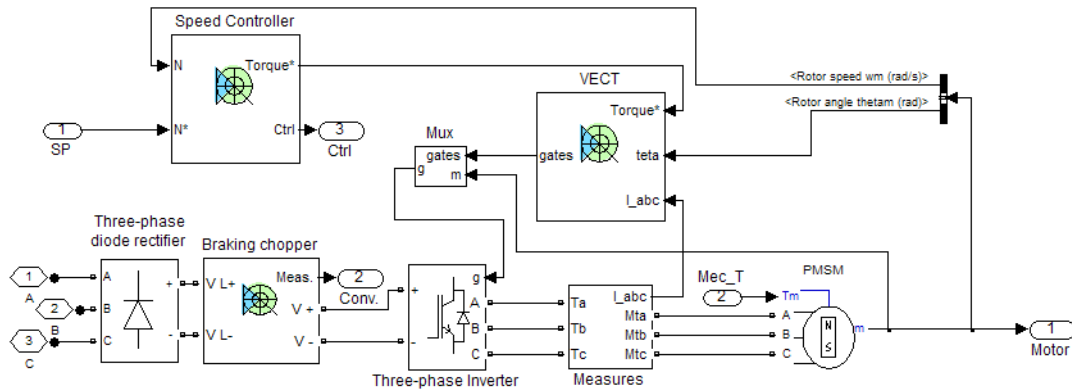

Speed Controller

The speed controller is based on a PI regulator, shown below. The output of this regulator is a torque set point applied to the vector controller block.

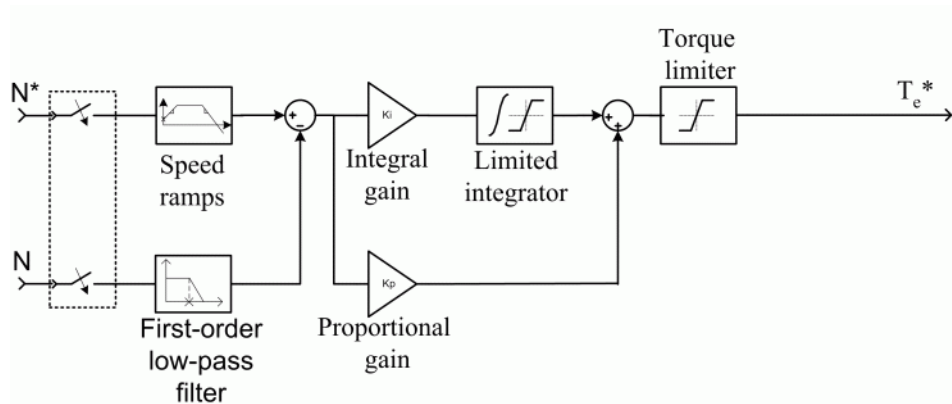

Vector Controller

The vector controller contains four main blocks, shown below. These blocks are described below.

PM Synchronous Motor Drive

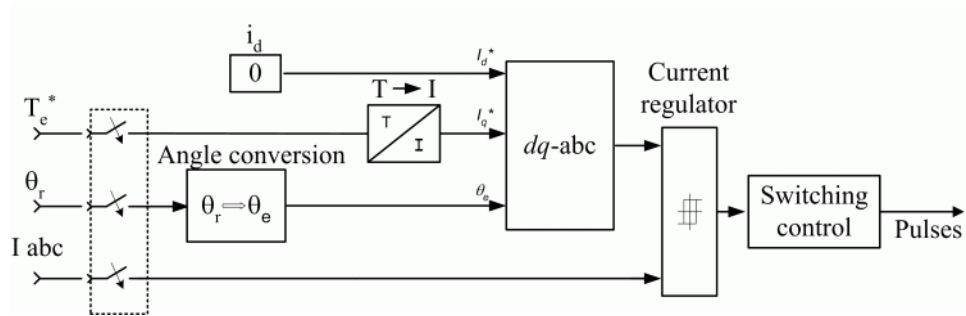

The *dq-abc* block performs the conversion of the *dq* current component in the rotor reference frame into *abc* phase variables.

The *current regulator* is a bang-bang current controller with adjustable hysteresis bandwidth.

The *angle conversion* block is used to compute the electrical rotor angle from the mechanical rotor angle.

The *Switching control* block is used to limit the inverter commutation frequency to a maximum value specified by the user.

When using the average-value inverter, the *ab* current references are sent to the inverter, as well as switching pulses from a slightly modified *Switching control* block.

Braking Chopper

The braking chopper block contains the DC bus capacitor and the dynamic braking chopper, which is used to absorb the energy produced by a motor deceleration.

Average-Value Inverter

The average-value inverter is shown in the following figure.

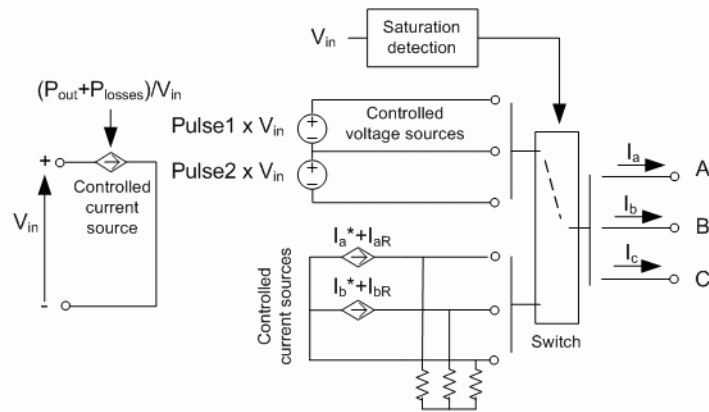

It is composed of one controlled current source on the DC side and of two controlled current sources and two controlled voltage sources on the AC side. The DC current source allows the representation of the average DC bus current behavior following the next equation:

$$I_{dc} = (P_{out} + P_{losses})/V_{in}$$

with P_{out} being the output power, P_{losses} the losses in the power electronic devices, and V_{in} the DC bus voltage.

On the AC side, the current sources represent the average phase currents fed to the motor. The regulation being fast, the current values are set equal to the current references sent by the current regulator. A small current is injected to compensate for the current drawn by the three-phase load (needed because of the inverter current sources in series with inductive motor).

During loss of current tracking due to insufficient inverter voltage, the currents are fed by two controlled voltage sources. These voltage sources represent the square wave mode and allow good representation of the phase currents during inverter saturation. Each voltage source outputs either V_{in} or 0, depending on the values of the pulses (1 or 0) sent by the current controller.

Remarks

The model is discrete. Good simulation results have been obtained with a $2 \mu s$ time step. To simulate a digital controller device, the control system has two different sampling times:

PM Synchronous Motor Drive

- Speed controller sampling time
- Vector controller sampling time

The speed controller sampling time has to be a multiple of the vector controller sampling time. The latter sampling time has to be a multiple of the simulation time step. The average-value inverter allows the use of bigger simulation time steps since it does not generate small time constants (due to the RC snubbers) inherent to the detailed converter. For a vector controller sampling time of 75 μs , good simulation results have been obtained for a simulation time step of 75 μs . The simulation time step can, of course, not be higher than the vector controller time step.

The stator current direct component i_d^* is set to zero inside the vector controller block because the rotor flux is supplied by the permanent magnets.

Dialog Box

PM Synchronous Machine Tab

The screenshot shows a dialog box titled "PM Synchronous Motor Drive". The main text reads: "The PM synchronous motor parameters are specified in the PMSM tab. The braking chopper, the diode rectifier and the inverter switches parameters are specified in the Converters and DC bus tab. Vector controller and speed controller parameters are specified in the controller tab." Below this text are three tabs: "Permanent Magnet Synchronous Machine" (selected), "Converters and DC bus", and "Controller".

The "Permanent Magnet Synchronous Machine" tab is divided into two sections:

- Electrical parameters:**
 - Resistance (ohm): 0.2
 - D-axis inductance (H): 8.5e-3
 - Q-axis inductance (H): 8.5e-3
 - Flux induced by magnets (Wb): 0.175
- Mechanical parameters:**
 - Inertia (kg*m²): 0.089
 - Friction (N-m-s): 0.005
 - Pole pairs: 4

At the bottom of the dialog, there is a "Model detail level" dropdown menu set to "Detailed", a "Parameters file options" section with "Load" and "Save" buttons, and a row of "OK", "Cancel", "Help", and "Apply" buttons.

The PM synchronous machine tab displays the parameters of the PM synchronous machine block of the powerlib library. Refer to Permanent Magnet Synchronous Machine for more information on the PM synchronous machine parameters.

PM Synchronous Motor Drive

Converters and DC Bus Tab

PM Synchronous Motor Drive

The PM synchronous motor parameters are specified in the PMSM tab. The braking chopper, the diode rectifier and the inverter switches parameters are specified in the Converters and DC bus tab. Vector controller and speed controller parameters are specified in the controller tab.

Permanent Magnet Synchronous Machine Converters and DC bus Controller

Rectifier

Snubbers

Resistance (ohm): 10e3

Capacitance (F): 20e-9

Diodes

On-state resistance (ohm): 1e-3

Forward voltage (V): 1.3

DC Bus

Capacitance (F): 2000e-6

Braking chopper

Resistance (ohm): 8

Chopper frequency (Hz): 4000

Activation voltage (V): 320

Shutdown voltage (V): 310

Inverter

Switches

Device type: IGBT / Diodes

On-state resistance (ohm): 1e-3

Forward voltages (V)

Main device: 0.8

Diode: 0.8

Turn-off characteristics

Fall time (s): 1e-6

Tail time (s): 2e-6

Snubbers

Resistance (ohm): 5000

Capacitance (F): inf

Model detail level: Detailed

Parameters file options

Load Save

OK Cancel Help Apply

Rectifier section

The rectifier section of the Converters and DC bus tab displays the parameters of the Universal Bridge block of the powerlib library. Refer to the Universal Bridge for more information on the universal bridge parameters.

Inverter section

The inverter section of the Converters and DC bus tab displays the parameters of the Universal Bridge block of the powerlib library. Refer to the Universal Bridge for more information on the universal bridge parameters.

The average-value inverter uses the following parameters.

Source frequency

The frequency of the three-phase voltage source (Hz).

On-state resistance

The on-state resistance of the inverter devices (ohms).

DC Bus Field — Capacitance

The DC bus capacitance (F).

Braking Chopper Section

Resistance

The braking chopper resistance used to avoid bus over-voltage during motor deceleration or when the load torque tends to accelerate the motor (ohms).

Frequency

The braking chopper frequency (Hz).

Activation Voltage

The dynamic braking is activated when the bus voltage reaches the upper limit of the hysteresis band. The following figure illustrates the braking chopper hysteresis logic.

Deactivation Voltage

The dynamic braking is shut down when the bus voltage reaches the lower limit of the hysteresis band. The chopper hysteresis logic is shown in the following figure.

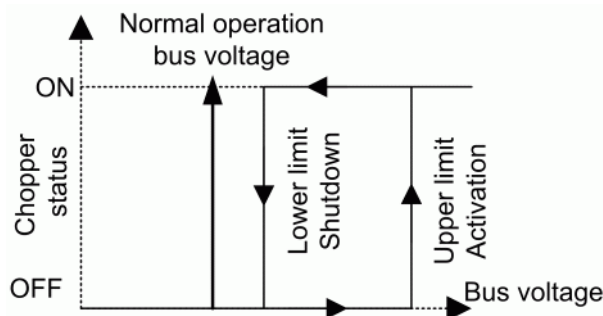

PM Synchronous Motor Drive

Controller Tab

The screenshot shows a software window titled "PM Synchronous Motor Drive" with a "Controller" tab selected. The window contains several sections for configuring motor drive parameters:

- Regulation type:** A dropdown menu set to "Speed regulation".
- Speed controller:**
 - Speed ramps (rpm/s):** Acceleration: 1000, Deceleration: -1000.
 - Speed cutoff frequency (Hz):** 100.
 - Speed controller sampling time (s):** 7*20e-6.
- PI regulator:**
 - Proportional gain:** 5.
 - Integral gain:** 100.
- Torque output limits (N-m):** Negative: -17.8, Positive: 17.8.
- Vector control:**
 - Sampling time (s):** 20e-6.
 - Current controller hysteresis band (A):** 0.1.
 - Maximum switching frequency (Hz):** 20e3.
- Model detail level:** A dropdown menu set to "Detailed".
- Parameters file options:** "Load" and "Save" buttons.

At the bottom of the window are "OK", "Cancel", "Help", and "Apply" buttons.

Regulation Type

This pop-up menu allows you to choose between speed and torque regulation.

Schematic Button

When you press this button, a diagram illustrating the speed and vector controllers schematics appears.

Speed Controller section

Speed Sensor Cutoff Frequency

The speed measurement first-order low-pass filter cutoff frequency (Hz).

Sampling Time

The speed controller sampling time (s). The sampling time must be a multiple of the simulation time step.

Speed Ramps — Acceleration

The maximum change of speed allowed during motor acceleration (rpm/s). An excessively large positive value can cause DC bus under-voltage.

Speed Ramps — Deceleration

The maximum change of speed allowed during motor deceleration (rpm/s). An excessively large negative value can cause DC bus overvoltage.

Proportional Gain

The speed controller proportional gain.

Integral Gain

The speed controller integral gain.

Output Limits — Negative

The maximum negative demanded torque applied to the motor by the vector controller (N.m).

Output Limits — Positive

The maximum positive demanded torque applied to the motor by the vector controller (N.m).

PM Synchronous Motor Drive

Vector Controller Section

Sampling Time

The vector controller sampling time (s). The sampling time must be a multiple of the simulation time step.

Hysteresis Bandwidth — Current

The current hysteresis bandwidth. This value is the total bandwidth distributed symmetrically around the current set point (A). The following figure illustrates a case where the current set point is I_s^* and the current hysteresis bandwidth is set to dx .

This parameter is not used when using the average-value inverter.

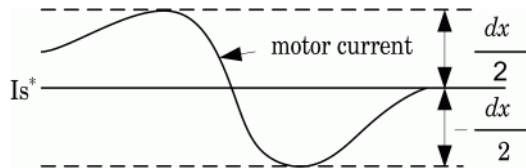

Maximum switching frequency

The maximum inverter switching frequency (Hz). This parameter is not used when using the average-value inverter.

Block Inputs and Outputs

SP

The speed or torque set point. Note that the speed set point can be a step function, but the speed change rate will follow the acceleration / deceleration ramps. If the load torque and the speed have opposite signs, the accelerating torque will be the sum of the electromagnetic and load torques.

Mec_T

The mechanical load torque input.

A, B, C

The three phase terminals of the motor drive.

Motor

The motor measurement vector. This vector allows you to observe the motor's variables using the Bus Selector block.

Conv

The three-phase converters measurement vector. This vector contains:

- The DC bus voltage
- The rectifier output current
- The inverter input current

Note that all current and voltage values of the bridges can be visualized with the Multimeter block.

Ctrl

The controller measurement vector. This vector contains:

- The torque reference
- The speed error (difference between the speed reference ramp and actual speed)
- The speed reference ramp or torque reference

Model Specifications

The library contains a 3 hp drive parameter set. The specifications of the 3 hp drive are shown in the following table.

3 HP Drive Specifications

Drive Input Voltage		
	Amplitude	220 V
	Frequency	60 Hz
Motor Nominal Values		
	Power	3 hp
	Speed	1800
	Voltage	300

Example

The `ac6_example` demo illustrates an AC6 motor drive simulation with standard load condition. At time $t = 0$ s, the speed set point is 300 rpm.

PM Synchronous Motor Drive

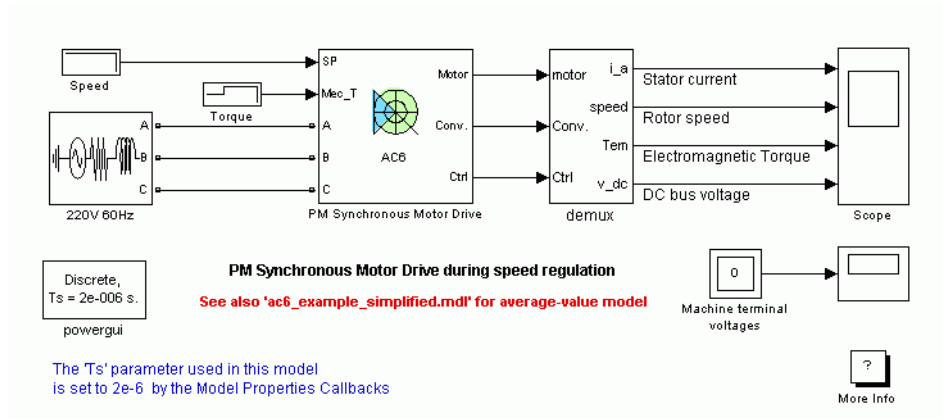

As shown in the following figure, the speed precisely follows the acceleration ramp. At $t = 0.5$ s, the nominal load torque is applied to the motor. At $t = 1$ s, the speed set point is changed to 0 rpm. The speed decreases to 0 rpm. At $t = 1.5$ s., the mechanical load passes from 11 N.m to -11 N.m. Average voltage, current, torque, and speed values are identical for both models. Notice that the higher frequency signal components are not represented with the average-value converter.

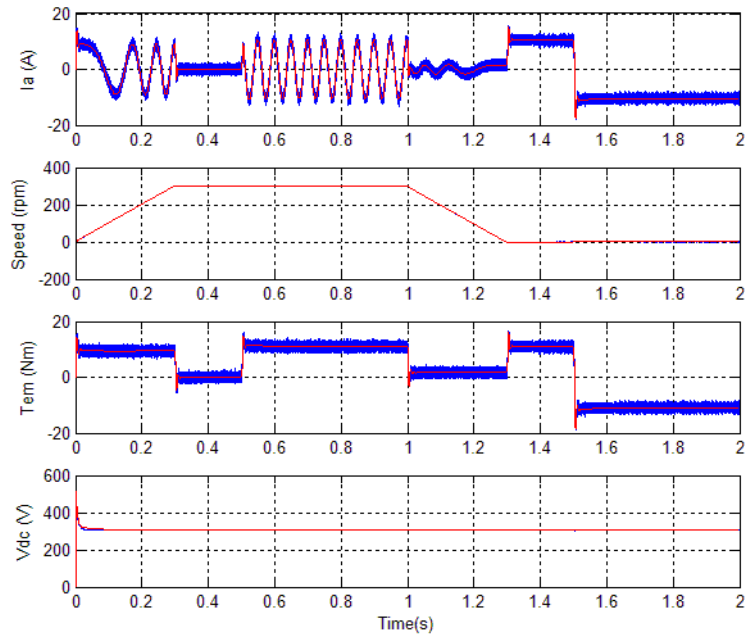

AC6 Example Waveforms (Blue : Detailed Converter, Red : Average-Value Converter)

References

- [1] Bose, B. K., *Modern Power Electronics and AC Drives*, Prentice-Hall, N.J., 2002.
- [2] Krause, P. C., *Analysis of Electric Machinery*, McGraw-Hill, 1986.

Powergui

Purposes Graphical user interface for the analysis of circuits and systems and the environment block for SimPowerSystems models

Library powerlib

Description The Powergui block is necessary for simulation of any Simulink model containing SimPowerSystems blocks. It is used to store the equivalent Simulink circuit that represents the state-space equations of the model.

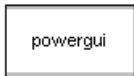

You must follow these rules when using this block in a model:

- Place the Powergui block at the top level of diagram for optimal performance. However, you can place it anywhere inside subsystems for your convenience; its functionality will not be affected.
- You can have a maximum of one Powergui block per model
- You must name the block powergui

What the Powergui Block Does

The main purpose of the Powergui block is to provide useful graphical user interface (GUI) tools for the analysis of SimPowerSystems models. It allows you to choose one of the following methods to solve your circuit:

- Continuous method, which uses a variable step solver from Simulink
- Discretization of the electrical system for a solution at fixed time steps
- Phasor solution method

The Powergui block also allows you to

- Display steady-state values of measured current and voltages as well as all state variables (inductor currents and capacitor voltages) in a circuit.
- Modify the initial electrical states in order to start the simulation from any initial conditions. The names of the electrical state variables are the name of the block where the capacitor or the inductor is found, preceded by the Uc_ label for capacitor voltages and by the IL_ label for the inductor currents.
- Perform load flows and initialize three-phase networks containing three-phase machines so that the simulation starts in steady state. This option is available with circuits containing the following types of machines:

Simplified Synchronous Machine, Synchronous Machine, or Asynchronous Machine (squirrel cage) blocks.

- Display impedance versus frequency plots when Impedance Measurement blocks are present in your circuit.
- Perform FFT analysis of the simulation results.
- Generate the state-space model (SS) of your system (if you have the Control System Toolbox installed) and automatically open the LTI Viewer interface for time and frequency domain responses.
- Generate a report containing steady-state values of the measurement blocks, the sources, the nonlinear models, and the states of your circuit. The report is saved in a file with the .rep extension.
- Model the hysteresis characteristic of the Saturable Transformer blocks.

Dialog Box and Parameters

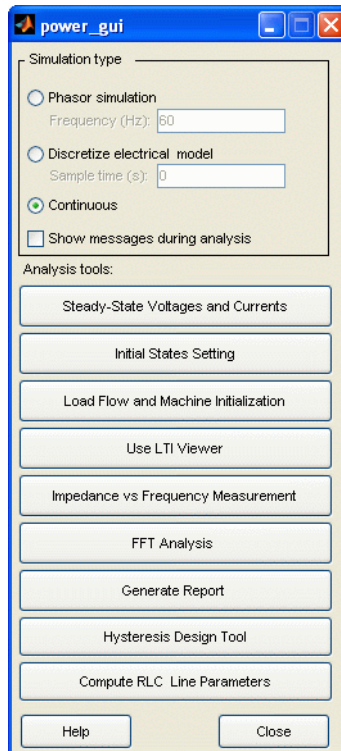

Simulation Type

Phasor simulation

If selected, SimPowerSystems performs a phasor simulation of the model, at the frequency specified by the **Frequency** parameter.

Frequency (Hz)

Specify the frequency used by SimPowerSystems to perform the phasor simulation of the model. The **Frequency** field is gray if **Phasor simulation** is not selected.

Discretize electrical model

If selected, SimPowerSystems performs a discretization of the model. The sample time is specified by the **Sample time** parameter.

Sample time(s)

Specify the sample time used to discretize the electrical circuit. Set the **Sample time** parameter to a value greater than 0. The icon displays the value of the sample time. If sample time is specified as 0, discretization is not performed, and the continuous solution method is used. The **Sample time** field is gray if the **Discretize electrical model** parameter is not selected.

Continuous

If selected, SimPowerSystems performs a continuous solution of the model.

Show messages during simulation

If selected, the command line echo messages of SimPowerSystems are enabled during the analysis and simulation of the model.

Analysis Tools

Steady-State Voltages and Currents

Open a window that displays the steady-state voltages and currents of the model.

Initial States Setting

Open a window that allows you to display and modify initial capacitor voltages and inductor currents of the model.

Load Flow and Machine Initialization

Open a window to perform load flow and machine initialization.

Use LTI Viewer

Open a window to use the LTI Viewer of the Control System Toolbox.

Impedance vs Frequency Measurement

Open a window that allows you to display the impedance versus frequency measurements performed by the Impedance Measurement blocks of the model.

FFT Analysis

Open a window to use the FFT analysis tool.

Generate Report

Open a window and generate a report of the steady-state calculations.

Hysteresis Design Tool

Open a window to design a hysteresis characteristic for the saturable core of the Saturable Transformer block and the Three-Phase Transformer blocks (two- and three-windings).

Steady-State Voltages and Currents GUI

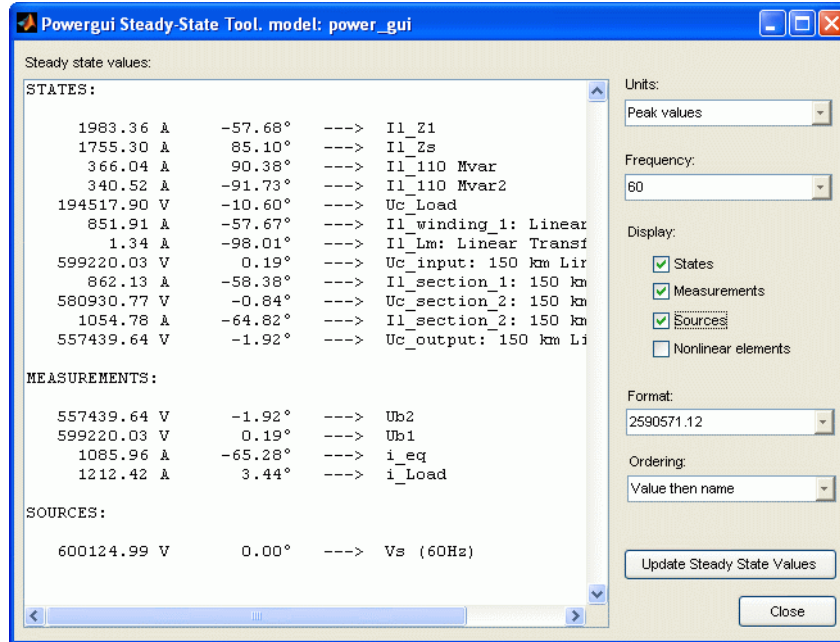

Steady state values

Display measurements of steady-state voltages and currents in the model.

Units

Set the **Units** parameter to **Peak values** to display the peak values of the selected values. Set the **Units** parameter to **RMS** to display the root-mean-square (RMS) values of the selected values.

Frequency

Allows you to choose the frequency, in hertz (Hz), that you want for display of the voltage and current phasors. The **Frequency** parameter lists all the different frequencies of the electrical sources of the model.

States

If selected, the window displays the steady-state phasors of the capacitor voltages and inductor currents of the circuit. The default is unselected.

Measurements

If selected, the window displays the steady-state voltage and current phasors of the measurement blocks of the circuit. The default is selected.

Sources

If selected, the window displays the steady-state voltage and current phasors of the electrical sources of the circuit. The default is unselected.

Nonlinear elements

If selected, the window displays the steady-state voltages and currents of the nonlinear blocks of the circuit. The default is unselected.

Format

In the pull-down menu, choose the format in which you want your measurements displayed. The floating point option is displayed in mantissa-exponent form with five significant figures. The best of option displays with four significant figures and uses mantissa-exponent form only for numbers larger than 9999. The final option is displayed in plain numbers with two figures to the right of the decimal point. The default is floating point.

Ordering

In the pull-down menu, choose the ordering in which you want your measurements displayed. The Value then name option displays the steady-state values in the first column followed by the names of the states variables. The Name then value option displays the name of the states variables in the first column followed by the steady-state values.

Update Steady State Values

Recompute and display the steady-state measurements.

Initial States Setting GUI

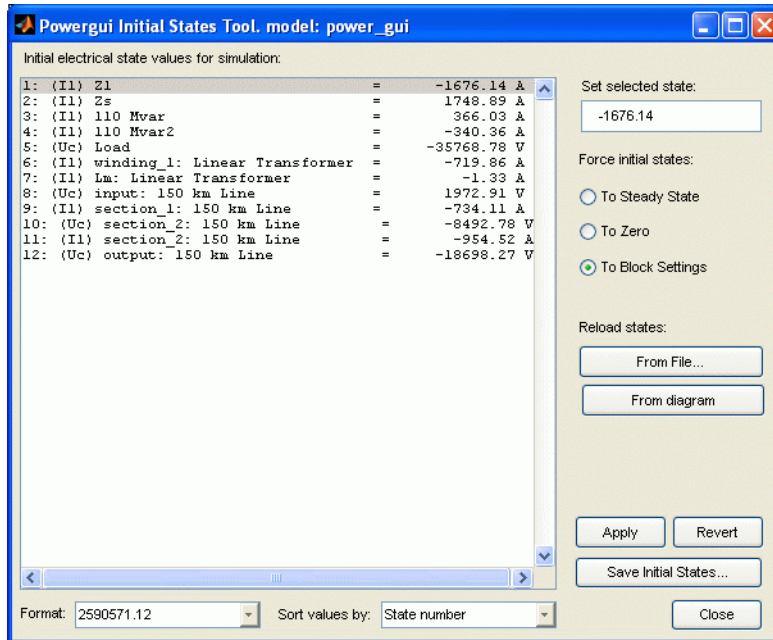

Initial state values for simulation

Display names of model state variables and their initial values.

Set selected state

Enter a value here to set the initial value of the variable selected in the **Initial state values for simulation** list.

Force initial states

If **To Steady State** is selected, force all initial electrical state values to steady-state values.

If **To Zero** is selected, force all initial electrical state values to zero.

If **To Block Settings** is selected, the initial electrical state values are set to the initial values specified in the mask of the Series RLC Branch, Parallel RLC Branch, Series RLC Load, and Parallel RLC Load blocks of

your model. The other initial electrical states are set by default to their steady-state values.

Reload states

If **From File** is selected, allows you to choose a previously saved file storing the model's states. If **From Diagram** is selected, sets all initial state values to their current values (either steady state values or last modified values).

Apply

Apply the chosen settings to the simulation.

Revert

Reapply the model's original settings from when this GUI was opened.

Save Initial States

Save the model's initial state settings in a file.

Format

In the pull-down menu, choose the format in which you want your measurements displayed. The floating point option is displayed in mantissa-exponent form with five significant figures. The best of option displays with four significant figures and uses mantissa-exponent form only for numbers larger than 9999. The final option is displayed in plain numbers with two figures to the right of the decimal point. The default is floating point.

Sort values by

Select order of displayed initial state values. Selecting `Default` order displays the value by block order in the diagram. Selecting `State number` displays the values according to the states' ordering in the state-space model. Selecting `Type` displays the values grouped by capacitors and inductors. The default is `Default` order.

Sign Conventions for Voltages and Currents

Unlike Simulink signal lines and input and output ports, the Physical Modeling connection lines and terminal ports of SimPowerSystems lack intrinsic directionality. The voltage and current polarities are determined, not by line direction, but instead by block orientation. To find out a block orientation, first click on the block to select it. Then enter the following command:

```
get_param(gcb, 'Orientation')
```

The following table indicates the polarities of the currents and voltages for single-phase and three-phase RLC elements (branches or loads), surge arresters, and single-phase and three-phase breakers. The table also indicates the polarities of their state variables (inductor currents and capacitor voltages).

Block Orientation	Positive Current Direction	Measured Voltage
right	left → right	Vleft – Vright
left	right → left	Vright – Vleft
down	top → bottom	Vtop – Vbottom
up	bottom → top	Vbottom – Vtop

The natural orientation of the blocks (that is, their orientation in the Element library) is *right* for horizontal blocks and *down* for vertical blocks.

For single-phase transformers (linear or saturable), with the winding connectors appearing on the left and right sides, the winding voltages are the voltages of the top connector with respect to the bottom connector whatever the block orientation (*right* or *left*). The winding currents are the currents entering the top connector. For three-phase transformers, the voltage polarities and positive current directions are indicated by the signal labels used in the Multimeter block.

Load Flow and Machine Initialization GUI

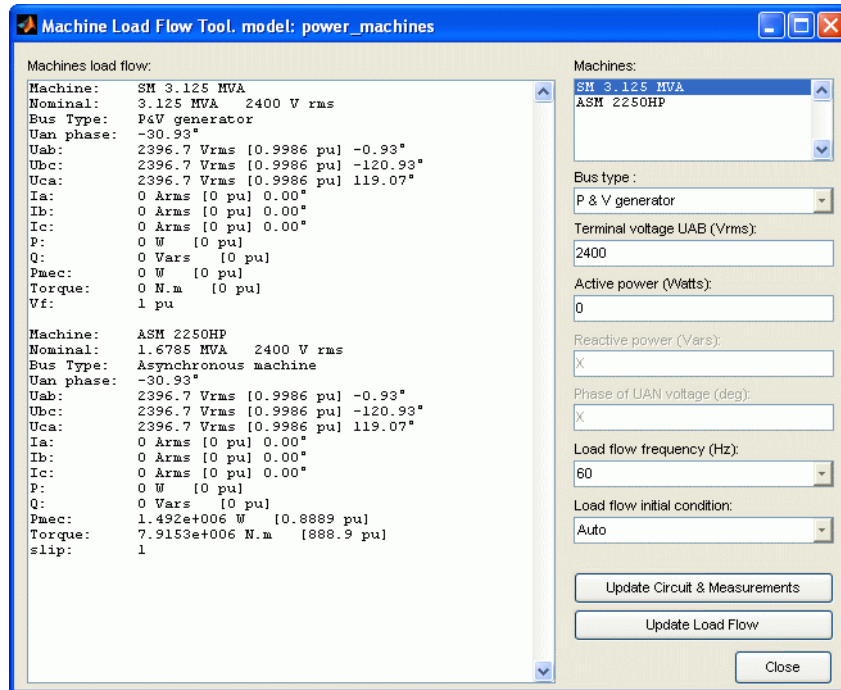

Machine load flow

Displays load flow characteristics of the machine selected in the **Machines** field.

Machines

Display the names of the Simplified Synchronous Machines, the Synchronous Machines, the Asynchronous Machine, and the Three-Phase Dynamic Load blocks of your model. Select a machine or a load in the list box in order to set its parameters for the load flow.

Bus type

If **Bus type** is set to P&V Generator, you can set the desired terminal voltage and active power of the machine. If **Bus type** is set to PQ generator, you can set the desired active and reactive powers. If **Bus type** is set to Swing Bus, you can set the desired terminal voltage, enter an active

power guess, and specify the phase of the UAN terminal voltage of the machine.

If you select an Asynchronous Machine block machine, you only have to enter the desired mechanical power delivered by the machine. If you select a Three-Phase Dynamic Load block, you have to specify the active and reactive powers consumed by the load.

Terminal voltage UAB

Specify the terminal line-to-line voltage of the selected machine.

Active power

Specify the active power of the selected machine or load.

Active power guess

Specify active power guess to start iterations when the specified machine bus type is Swing Bus.

Reactive power

Specify the reactive power of the selected machine or load.

Phase of UAN voltage

This parameter is activated only when the bus type is Swing Bus.

Specify the phase of the phase-to-neutral voltage of phase A of the selected machine.

Mechanical power

In motor mode, specify the mechanical power developed by the squirrel cage induction machine. In generator mode, specify the mechanical power absorbed by the machine as a negative number.

Load flow frequency

Specify the frequency to be used in the load flow calculations (normally 60 Hz or 50 Hz).

Load flow initial condition

Normally, you should keep the default setting **Auto** to let the load flow automatically adjust the initial conditions before starting iterations. If you select **Start from previous solution**, the load flow starts with initial conditions corresponding to the previous solution. Try this option if the

load flow fails to converge after a change has been made to the power and voltage settings of the machines or to the circuit parameters.

Update Circuit & Measurements

Update the list of machines, voltage and current phasors, as well as the powers in the load flow window if you have made a change in your model while the load flow window is open. The new voltages and powers displayed in the load flow window are computed by using the machine currents obtained from the last load flow (the three currents stored in the **Initial conditions** parameter of the machine blocks).

Execute Load Flow

Executes the load flow calculations for the given load flow parameters.

Use LTI Viewer GUI

This tool can be used to create a state-space object (SS) of the linear part of the electrical circuit (ABCD state-space matrices representing the RLC devices in the model). All the nonlinear elements, such as the distributed parameter line blocks, will be considered as inputs and outputs to the SS object (because they are modeled as current source in feedback to the state-space system). You can analyze the time and frequency responses of this SS object with the LTI Viewer tools.

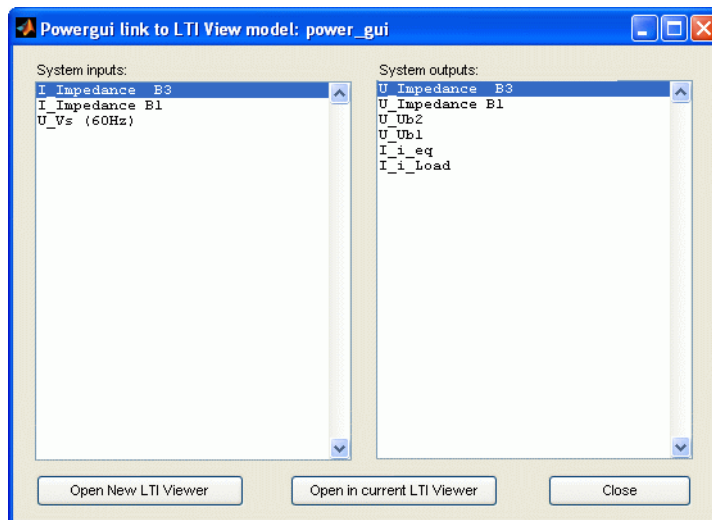

System inputs

Lists the inputs of the state-space model of your circuit. Select the inputs to be used by the LTI Viewer.

System outputs

Lists the outputs of the state-space model of your circuit. Select the outputs to be used by the LTI Viewer.

Open New LTI Viewer

Generate the state-space model of the circuit and opens the LTI viewer for the selected system inputs and outputs.

Impedance vs Frequency Measurement GUI

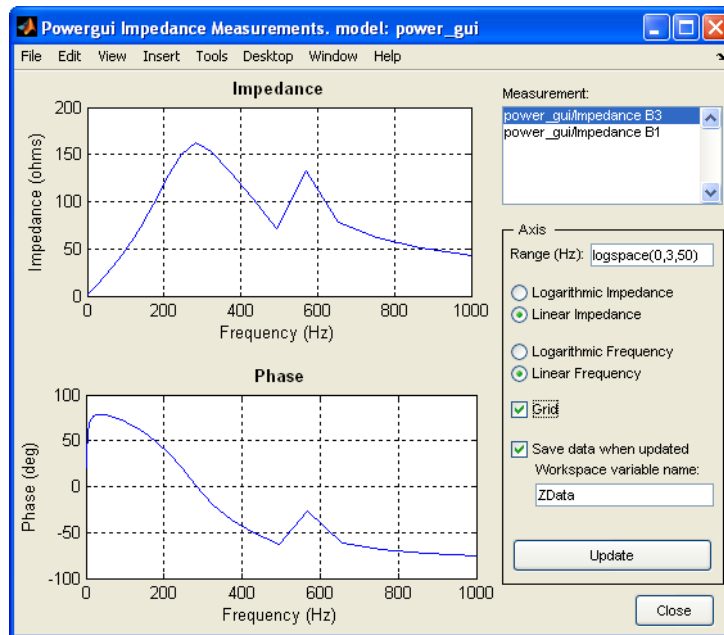

Measurement

Lists the Impedance Measurement blocks of the model. Select the blocks for which you want to obtain the frequency response. Use the CTRL key to select several impedances to be displayed on the same plot.

Axis**Range (Hz)**

Specify the frequency vector, in hertz (Hz). You can specify in that field any valid MATLAB expression defining a vector of frequencies; for example, `0:2:1000` or `linspace(0,1000,500)`. The default is `logspace(0,3,50)`.

Logarithmic Impedance/Linear Impedance

Choose logarithmic or linear scale for the vertical impedance scale.

Logarithmic Frequency/Linear Frequency

Choose logarithmic or linear scale for the horizontal frequency scales.

Grid

If selected, a grid is displayed for the two plots. Default is unselected.

Save data when updated

If selected, data are saved in a variable in the workspace. The name of the variable is defined by the **Workspace variable name** parameter. The complex impedances are saved in an array together with the corresponding frequencies. Frequency is saved in column 1 and impedances are saved in the next columns. Default is unselected.

Display/Save or Update

Click to initially display the impedance versus frequency measurement and, if the **Save data when updated** check box is selected, save the data to your workspace.

Click to start the impedance versus frequency measurement again and display results after multiple runs of your model.

FFT Analysis GUI

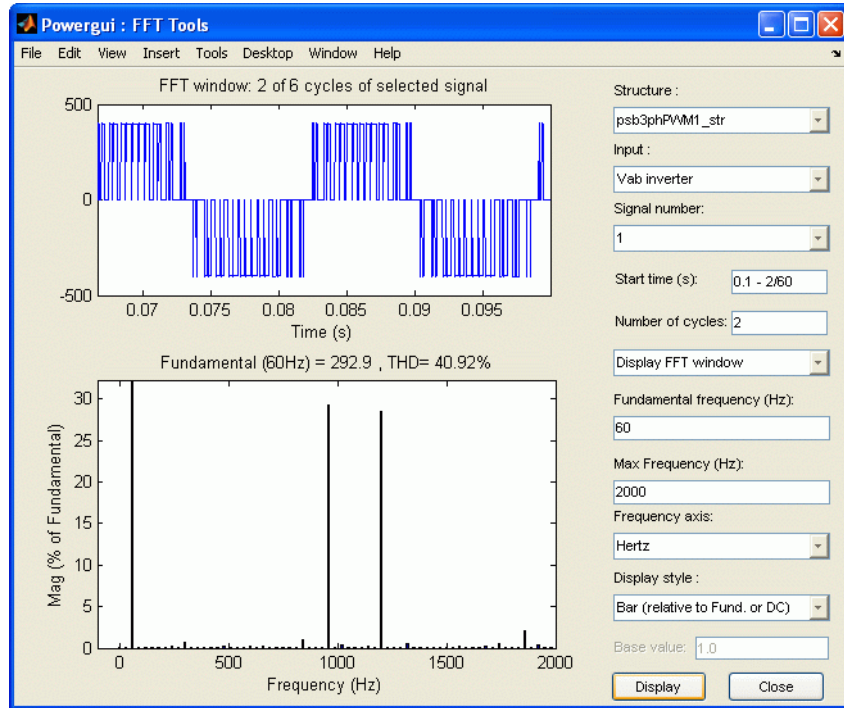

Structure

Lists the structures with time variables that are present in your workspace. You first need to run a simulation of your model. These structures are generated by the Scope or To Workspace blocks in your model. The signals must be sampled at a fixed rate, by using the Scope block settings. Use the pull-down menu to select the variable you want to analyze.

Input

Select the input signal of the selected structure with time variables specified in the **Structure** field. Structures with time variables with multiple inputs can be generated by a Scope block having multiple input ports.

Signal Number

Specify the index of the selected input signal specified by the **Input** parameter. For example, the **Signal Number** parameter allows you to select the phase A signal of a three-phase signal connected to input 2 of a Scope block.

Start time(s)

Specify the start times for the FFT analysis. The FFT analysis will be performed on the portion of the signal starting at the specified time and for the specified number of cycles.

Number of cycles

Specify the number of cycles of the selected signal to analyze for the FFT analysis.

Display FFT window/Display entire signal

In the pull-down menu, select **Display entire signal** to display the entire selected signal in the upper plot. Select **Display FFT window** to display only the portion of the signal where the FFT analysis is performed.

Fundamental frequency

Specify the fundamental frequency, in hertz (Hz), as a reference frequency for the FFT analysis.

Max Frequency

Specify the maximum frequency, in hertz (Hz), for the FFT analysis.

Frequency axis

In the pull-down menu, select **Hertz** to display the spectrum frequency axis in hertz. Select **Harmonic order** to display the spectrum frequency axis in harmonic order relative to the fundamental frequency.

Display style

In the pull-down menu, select **Bar (relative to Fund. or DC)** to display the spectrum as a bar graph relative to the fundamental frequency. Select **Bar (relative to specified base)** to display the spectrum as a bar graph relative to the base defined by the **Base value** parameter.

Select **List (relative to Fund. or DC)** to display the spectrum as a list in % relative to the fundamental or DC component. Select **List (relative to**

specified base) to display the spectrum as a list in % relative to the base value defined by the **Base value** parameter.

Base value

Enter a base value for the display of harmonics.

Display

Display the FFT analysis results for the selected measurement.

An example using the FFT tool is described in “Performing Harmonic Analysis Using the FFT Tool” on page 2-20.

Generate Report GUI

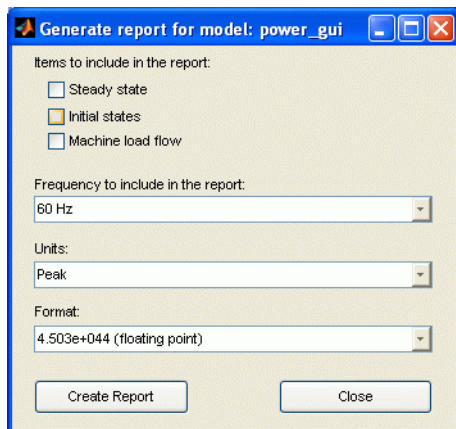

Items to include in the report

In the check boxes, select any combination of measurements to include in the generated report, **Steady state**, **Initial states**, and **Machine load flow**. The default is unselected for all three.

Frequency to include in the report

Select the frequency or frequencies to include in the generated report, 60 Hz or All. The default is 60 Hz.

Units

Set the **Units** parameter to `Peak` values to display the peak values of the selected values. Set the **Units** parameter to `RMS` to display the root-mean-square (RMS) values of the selected values.

Format

In the pull-down menu, choose the format in which you want your measurements displayed. The `floating point` option is displayed in mantissa-exponent form with five significant figures. The `best of` option is displayed with four significant figures and uses mantissa-exponent form only for numbers larger than 9999. The `final` option is displayed in plain numbers with two figures to the right of the decimal point. The default is `floating point`.

Create Report

Generate a report and save it to a file.

Hysteresis Design Tool GUI

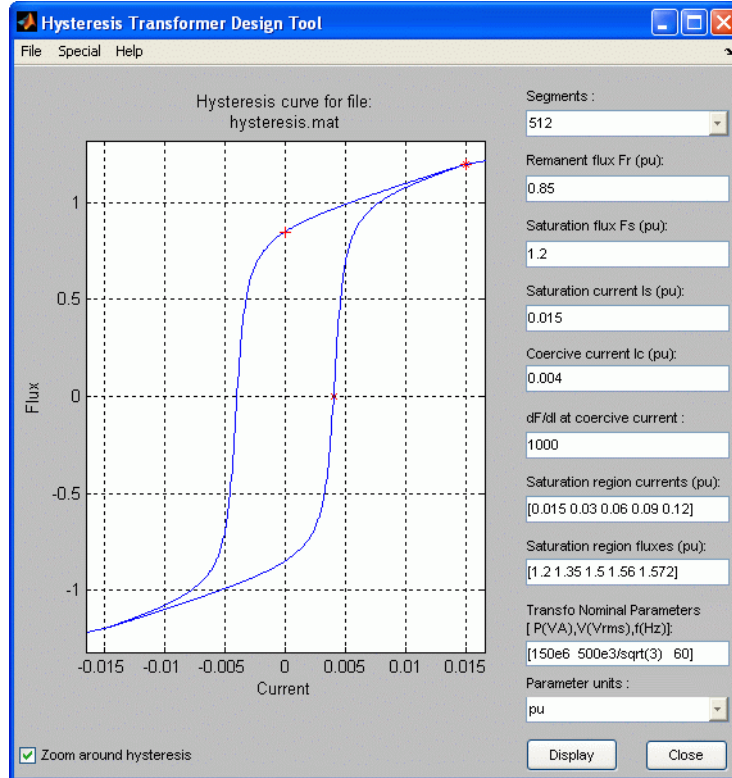

To learn more about hysteresis modeling, see the Saturable Transformer block reference pages.

Segments

In the pull-down menu, specify the number of linear segments used to define the right side of the hysteresis loop. The left side of the loop is the symmetric image of the right side.

Remanent flux F_r

Specify the remanent flux point of the hysteresis characteristic (flux at zero current).

Saturation Flux F_s

Specify the saturation flux point where the hysteresis loop becomes a single-valued saturation curve.

Saturation current I_s

Specify the saturation current point where the hysteresis loop becomes a single-valued saturation curve. The saturation region is defined by the **Saturation region currents** parameter.

Coercive current I_c

Specify the coercive current point of the hysteresis characteristic.

dF/dI at coercive current

Set the slope of the flux at the coercive current point (current at zero flux).

Saturation region currents

Specify the vector of current values that define the saturation characteristic. The number of specified points must be the same as for the **Saturation region fluxes** parameter. You only need to specify the positive part of the characteristic.

Saturation region fluxes

Specify the vector of flux values that define the saturation characteristic. The number of specified points must be the same as for the **Saturation region currents** parameter. You only need to specify the positive part of the characteristic.

Transfo Nominal Parameters

Specify the nominal parameters (nominal power in VA, nominal voltage of winding 1 in volts RMS, and nominal frequency in Hz) used in the conversion of the hysteresis parameters.

Parameter units

Convert the fluxes and currents that define the hysteresis characteristic from SI to p.u. or from p.u. to SI.

Zoom around the hysteresis

If selected, zoom the plot around the hysteresis curve. The default is selected.

Powergui

Example

Open the demos of SimPowerSystems and double-click the Powergui block contained in the model. For each demo, you can use the tools of the Powergui to look at the initial values and steady-state values of the inductor currents and capacitor voltages. For demos containing machines, you can edit and perform a machine load flow analysis.

See Also

Multimeter, Saturable Transformer, power_init

Purpose

Generate pulses for a carrier-based two-level pulse width modulator (PWM) in converter bridge

Library

Extras/Control Blocks

A discrete version of this block is available in the Extras/Discrete Control Blocks library.

Description



The PWM Generator block generates pulses for carrier-based pulse width modulation (PWM) converters using two-level topology. The block can be used to fire the forced-commutated devices (FETs, GTOs, or IGBTs) of single-phase, two-phase, three-phase, two-level bridges or a combination of two three-phase bridges.

The number of pulses generated by the PWM Generator block is determined by the number of bridge arms you have to control:

- Two pulses are generated for a one-arm bridge. Pulse 1 fires the upper device and pulse 2 fires the lower device (shown for the IGBT device).

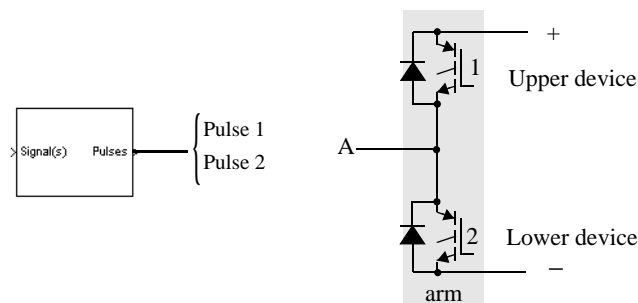

PWM Generator

- Four pulses are generated for a two-arm bridge. Pulses 1 and 3 fire the upper devices of the first and second arm. Pulses 2 and 4 fire the lower devices.

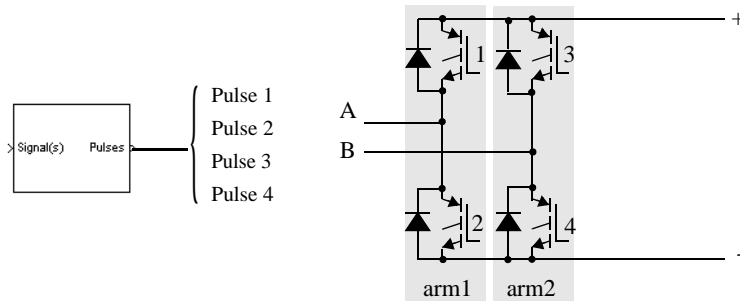

- Six pulses are generated for a three-arm bridge. Pulses 1, 3, and 5 fire the upper devices of the first, second, and third arms. Pulses 2, 4, and 6 fire the lower devices.

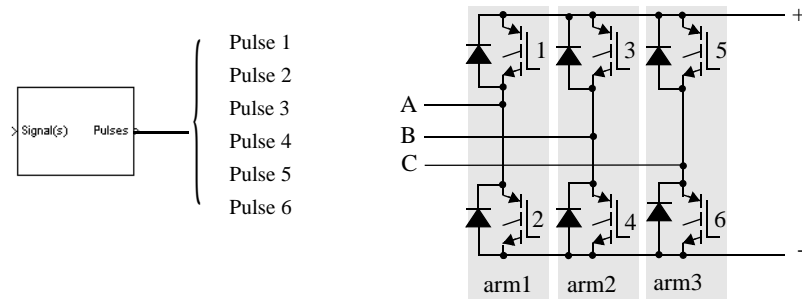

- Twelve pulses are generated for a double three-arm bridge. The first six pulses (1 to 6) fire the six devices of the first three-arm bridge and the last six pulses (7 to 12) fire the six devices of the second three-arm bridge.

For each arm the pulses are generated by comparing a triangular carrier waveform to a reference modulating signal. The modulating signals can be generated by the PWM generator itself, or they can be a vector of external signals connected at the input of the block. One reference signal is needed to generate the pulses for a single- or a two-arm bridge, and three reference

signals are needed to generate the pulses for a three-phase, single or double bridge.

The amplitude (modulation), phase, and frequency of the reference signals are set to control the output voltage (on the AC terminals) of the bridge connected to the PWM Generator block.

The two pulses firing the two devices of an arm bridge are complementary. For example, pulse 4 is low (0) when pulse 3 is high (1). This is illustrated in the next two figures.

The following figure displays the two pulses generated by the PWM Generator block when it is programmed to control a one-arm bridge.

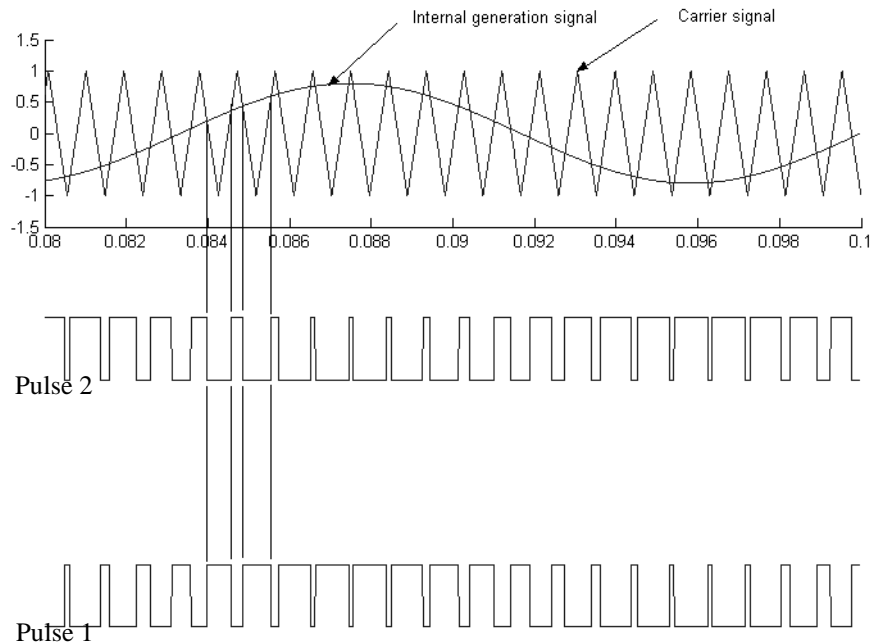

The triangular carrier signal is compared with the sinusoidal modulating signal. When the modulating signal is greater than the carrier pulse 1 is high (1) and pulse 2 is low (0).

PWM Generator

For a single-phase two-arm bridge the modulating signal used for arm 2 is the negative of modulating signal used for arm 1 (180 degrees phase shift). For a three-phase six-arm bridge the three modulating signals used for bridge 2 are the negative of the modulating signals applied to bridge 1.

The following figure displays the six pulses generated by the PWM Generator block when it is programmed to control a three-arm bridge.

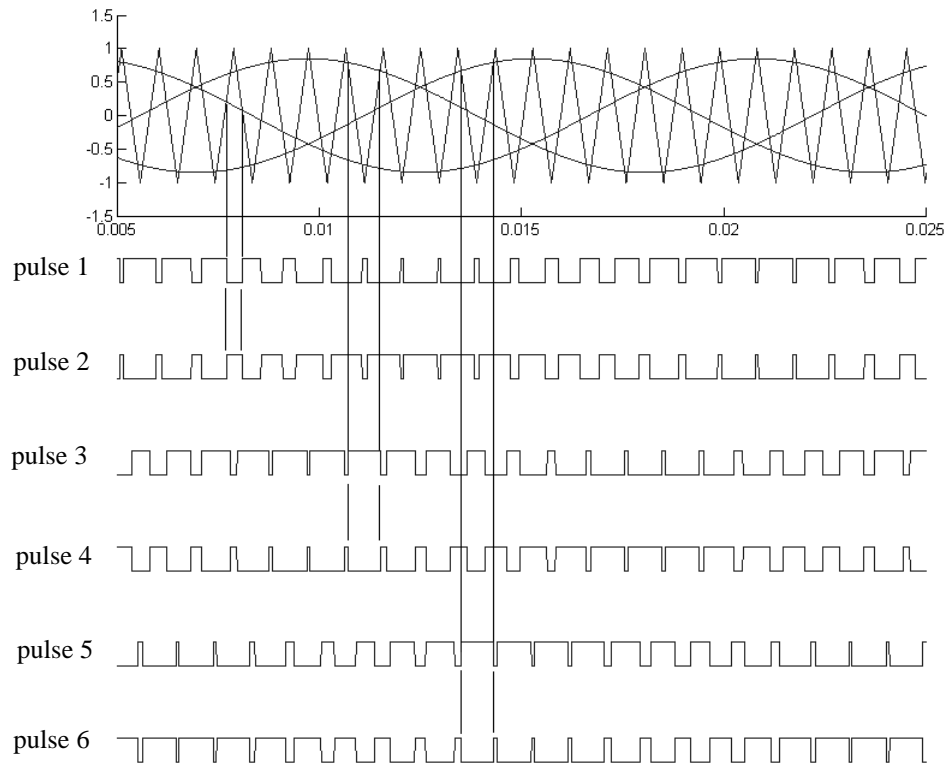

Dialog Box and Parameters

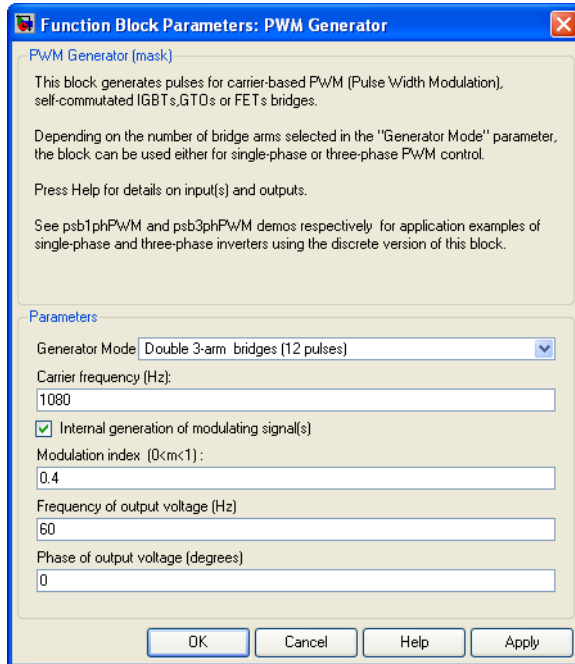

Generator Mode

Specify the number of pulses to generate. The number of pulses is proportional to the number of bridge arms to fire. Select for example **Double 3-arm bridges (12 pulses)** to fire the self-commutated devices of two six-pulse bridges connected in a twelve-pulse bridge configuration.

Carrier frequency

The frequency, in hertz, of the carrier triangular signal.

Internal generation of modulating signal

If selected, the modulating signal is generated by the block. Otherwise, external modulating signals are used for pulse generation.

PWM Generator

Modulation index ($0 < m < 1$)

The **Modulation index** parameter is visible only if the **Internal generation of modulating signal (s)** parameter is selected.

The amplitude of the internal sinusoidal modulating signal. The **Modulation index** must be greater than 0, and lower than or equal to 1. This parameter is used to control the amplitude of the fundamental component of the output voltage of the controlled bridge.

Frequency of output voltage

The **Frequency of output voltage (Hz)** parameter is visible only if the **Internal generation of modulating signal (s)** parameter is selected.

The frequency, in hertz, of the internal modulating signals. This parameter is used to control the fundamental frequency of the output voltage of the controlled bridge.

Phase of output voltage

The **Phase of output voltage** parameter is visible only if the **Internal generation of modulating signal (s)** parameter is selected.

The phase, in degrees, of the internal modulating signal. This parameter is used to control the phase of the fundamental component of the output voltage of the controlled bridge.

Inputs and Outputs

Signal(s)

The input is not visible when **Internal generation of modulating signal (s)** is selected.

The input is the vector of modulating signals when **Internal generation of modulating signal** is not selected. Connect this input to a single-phase sinusoidal signal when the block is used to control a single- or a two-arm bridge, or to a three-phase sinusoidal signal when the PWM Generator block is controlling one or two three-phase bridges.

Pulses

The output contains the two, four, six, or twelve pulse signals used to fire the self-commutated devices (MOSFETs, GTOs, or IGBTs) of single-phase, two-phase, or three-phase bridges or a combination of two three-phase bridges.

Example

See the power_1phPWM and power_3phPWM demos for examples of single-phase and three-phase two-level inverters.

See Also

Universal Bridge

RMS

Purpose Measure the root mean square (RMS) value of a signal

Library Extras/Measurements

A discrete version of this block is available in the Extras/Discrete Measurements library.

Description

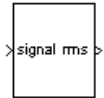

This block measures the root mean square value of an instantaneous current or voltage signal connected to the input of the block. The RMS value of the input signal is calculated over a running average window of one cycle of the specified fundamental frequency.

$$RMS(f(t)) = \sqrt{\frac{1}{T} \int_{(t-T)}^t f(t)^2}$$

$f(t)$: input signal, $T = 1/\text{fundamental frequency}$

as this block uses a running average window, one cycle of simulation has to be completed before the output gives the correct value. The discrete version of this block allows you to specify the initial magnitude of inputs. For the first cycle of simulation the output is held to the RMS value of the specified initial input.

Dialog Box and Parameters

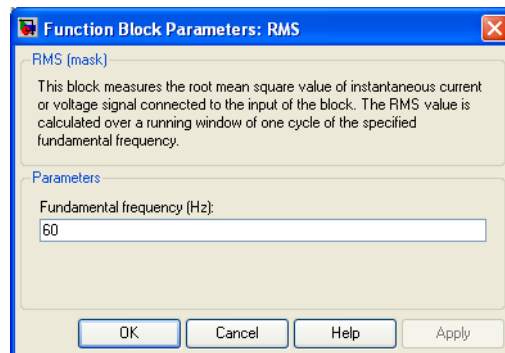

Fundamental frequency

The fundamental frequency, in hertz, of the input signal.

Example

In the power_control1volt demo, you can add an RMS block as shown below to measure the RMS value of the capacitor voltage. The Controlled Voltage Source block introduces a third harmonic (180 Hz) in the voltage at $t = 0.4$ seconds.

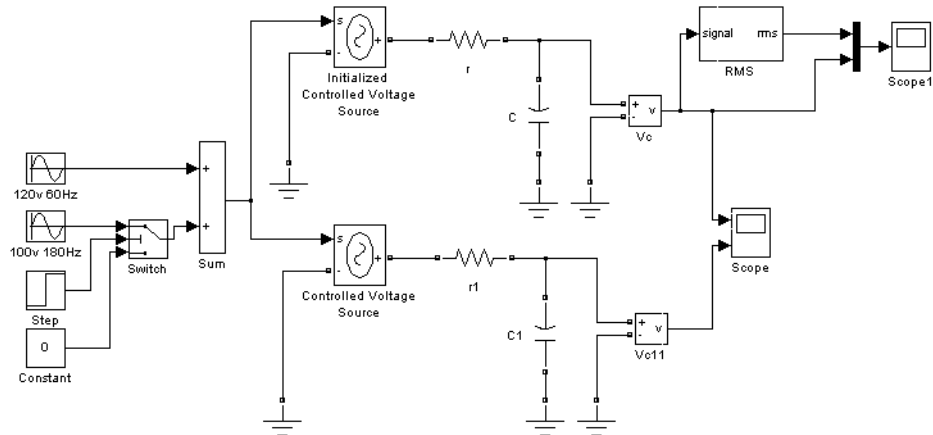

At the beginning of the simulation, the RMS block needs one cycle of the fundamental frequency (60Hz) to calculate the RMS value of the voltage. At $t = 0.4$ seconds the RMS value slightly increases because of the addition of the third harmonic in the signal. Again, the RMS block needs one cycle of the fundamental signal to stabilize and give the correct result.

RMS

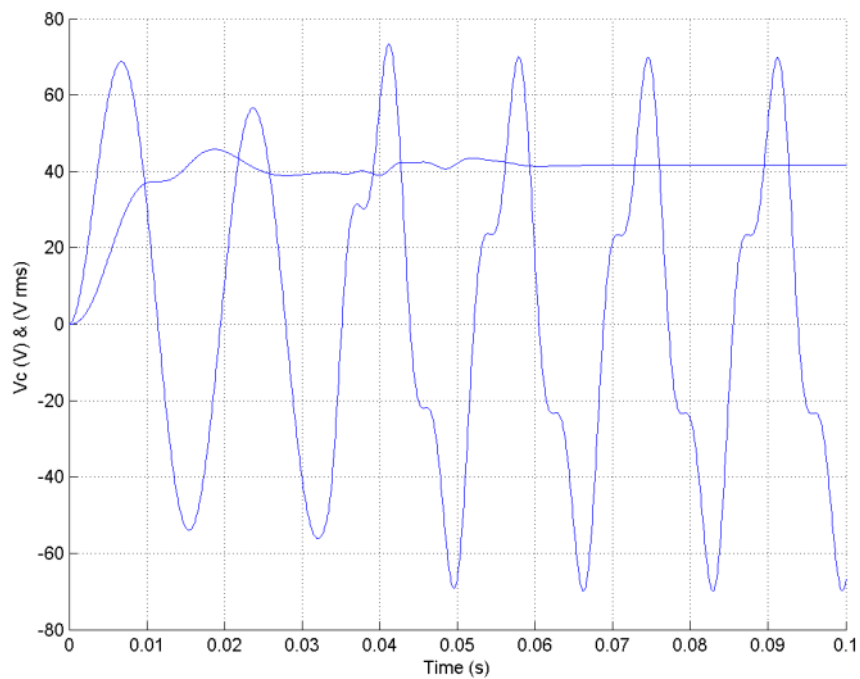

Purpose Implement a two- or three-winding saturable transformer

Library Elements

Description The Saturable Transformer block model shown consists of three coupled windings wound on the same core.

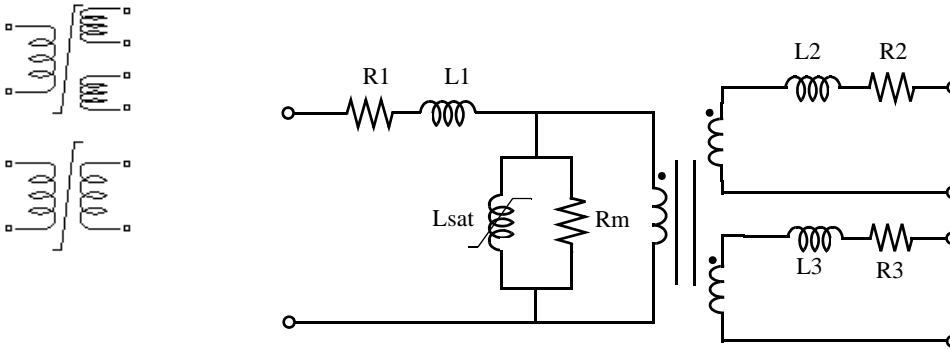

The model takes into account the winding resistances (R_1 R_2 R_3) and the leakage inductances (L_1 L_2 L_3) as well as the magnetizing characteristics of the core, which is modeled by a resistance R_m simulating the core active losses and a saturable inductance L_{sat} .

You can choose one of the following two options for the modeling of the nonlinear flux-current characteristic

- 1 Model saturation without hysteresis. The total iron losses (eddy current + hysteresis) are modeled by a linear resistance, R_m .
- 2 Model hysteresis and saturation. Specification of the hysteresis is done by means of the **Hysteresis Design Tool** of the Powergui block. The eddy current losses in the core are modeled by a linear resistance, R_m .

Note Modeling the hysteresis requires additional computation load and therefore slows down the simulation. The hysteresis model should be reserved for specific applications where this phenomenon is important.

Saturable Transformer

Saturation Characteristic Without Hysteresis

When the hysteresis is not modeled, the saturation characteristic of the Saturable Transformer block is defined by a piecewise linear relationship between the flux and the magnetization current.

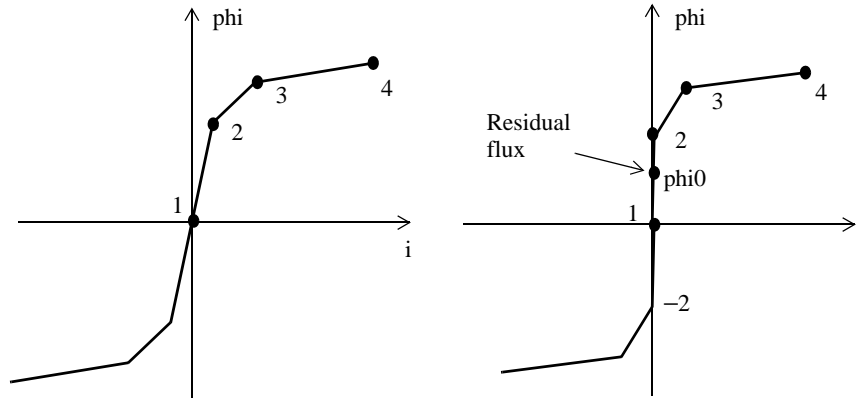

(a) No residual flux can be specified.

(b) A residual flux can be specified between points 2 and -2.

Therefore, if you want to specify a residual flux, ϕ_{i0} , the second point of the saturation characteristic should correspond to a null current, as shown in the figure (b).

The saturation characteristic is entered as (i, phi) pair values in per units, starting with pair (0, 0). SimPowerSystems converts the vector of fluxes Φ_{pu} and the vector of currents I_{pu} into standard units to be used in the saturation model of the Saturable Transformer block:

$$\Phi = \Phi_{pu} \Phi_{base}$$

$$I = I_{pu} I_{base}$$

where the base flux linkage (Φ_{base}) and base current (I_{base}) are the peak values obtained at nominal voltage power and frequency:

$$I_{base} = \frac{P_n}{V_1} \sqrt{2} \quad \Phi_{base} = \frac{V_1}{2\pi f_n} \sqrt{2} \text{ (Flux linkage in volts-seconds)}$$

The base flux is defined as the peak value of the sinusoidal flux (in webers) when winding 1 is connected to a 1 p.u. sinusoidal voltage source (nominal voltage). The Φ_{base} value defined above represents the base flux linkage (in volt-seconds). It is related to the base flux by the following equation:

$$\Phi_{base} = \text{Base flux} \times \text{number of turns of winding 1}$$

When they are expressed in p.u., the flux and the flux linkage have the same value.

Saturation Characteristic with Hysteresis

The magnetizing current I is computed from the flux Φ obtained by integrating voltage across the magnetizing branch. The static model of hysteresis defines the relation between flux and the magnetization current evaluated in DC, when the eddy current losses are not present.

The hysteresis model is based on a semi empirical characteristic, using an arctangent analytical expression $\Phi(I)$ and its inverse $I(\Phi)$ to represent the operating point trajectories. The analytical expression parameters are obtained by curve fitting empirical data defining the major loop and the single-valued saturation characteristic. The **Hysteresis design tool** of the Powergui block is used to fit the hysteresis major loop of a particular core type to basic parameters. These parameters are defined by the remanent flux (Φ_r), the coercive current (I_c), and the slope ($d\Phi/dI$) at $(0, I_c)$ point as shown in the next figure.

Saturable Transformer

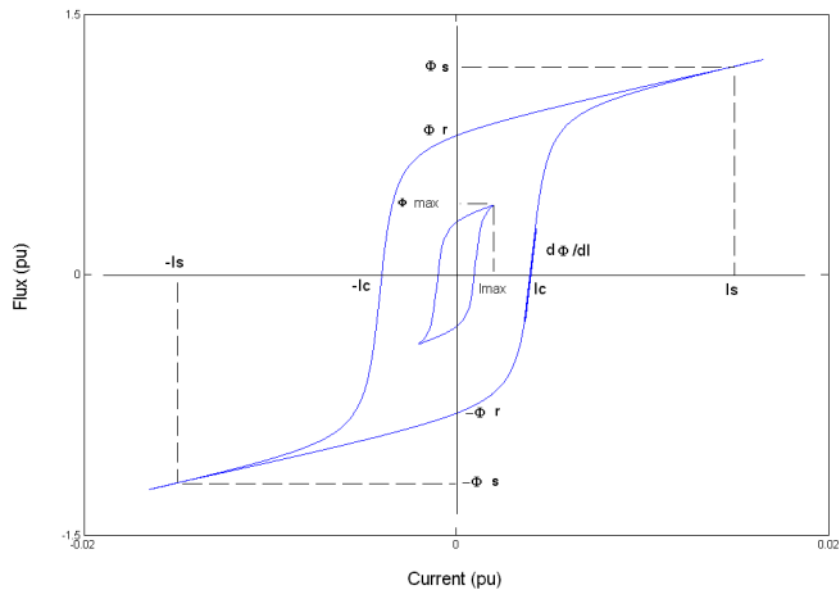

The major loop half cycle is defined by a series of N equidistant points connected by line segments. The value of N is defined in the **Hysteresis design tool** of the Powergui block. Using $N = 256$ yields a smooth curve and usually gives satisfactory results.

The single-valued saturation characteristic is defined by a set of current-flux pairs defining a saturation curve which should be asymptotic to the air core inductance L_s .

The main characteristics of the hysteresis model are summarized below:

- 1 A symmetrical variation of the flux produces a symmetrical current variation between $-I_{max}$ and $+I_{max}$, resulting in a symmetrical hysteresis loop whose shape and area depend on the value of Φ_{max} . The major loop is produced when Φ_{max} is equal to the saturation current (Φ_s). Beyond that point the characteristic reduces to a single-valued saturation characteristic.
- 2 In transient conditions, an oscillating magnetizing current produces minor asymmetrical loops, as shown in the next figure, and all points of operation are assumed to be within the major loop. Loops once closed have no more influence on the subsequent evolution.

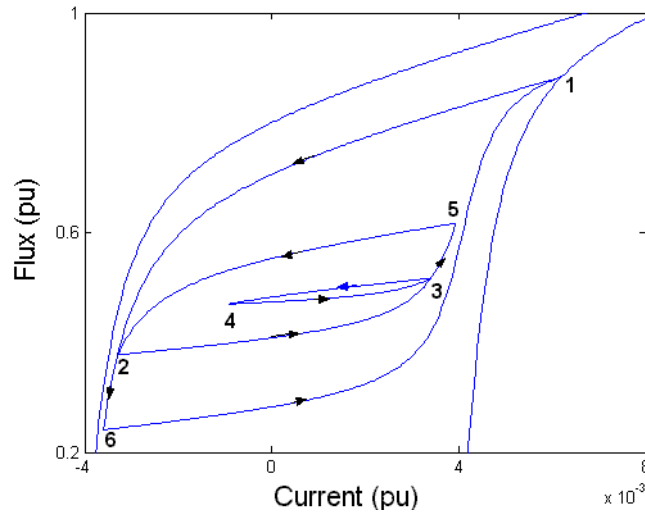

The trajectory starts from the initial (or residual) flux point, which must lie on the vertical axis inside the major loop. You can specify this initial flux value ϕ_{i0} , or it is automatically adjusted so that the simulation starts in steady state.

The Per Unit Conversion

In order to comply with industry practice, you must specify the resistance and inductance of the windings in per unit (p.u.). The values are based on the transformer rated power P_n in VA, nominal frequency f_n in Hz, and nominal voltage V_n , in V_{rms}, of the corresponding winding. For each winding the per unit resistance and inductance are defined as

$$R(\text{p.u.}) = \frac{R(\Omega)}{R_{base}}$$

$$L(\text{p.u.}) = \frac{L(H)}{L_{base}}$$

Saturable Transformer

The base resistance and base inductance used for each winding are

$$R_{base} = \frac{(V_n)^2}{P_n}$$
$$L_{base} = \frac{R_{base}}{2\pi f_n}$$

For the magnetization resistance R_m , the p.u. values are based on the transformer rated power and on the nominal voltage of winding 1.

The default parameters of winding 1 specified in the dialog box section give the following base values:

$$R_{base} = \frac{(735e3/\sqrt{3})^2}{250e6} = 720.3\Omega \quad L_{base} = \frac{720.3}{2\pi 60} = 1.91H$$

For example, if winding 1 parameters are $R_1 = 1.44 \Omega$ and $L_1 = 0.1528 H$, the corresponding values to enter in the dialog box are

$$R_1 = \frac{1.44\Omega}{720.3\Omega} = 0.002 \text{ p.u.}$$
$$L_1 = \frac{0.1528H}{1.91H} = 0.08 \text{ p.u.}$$

Dialog Box and Parameters

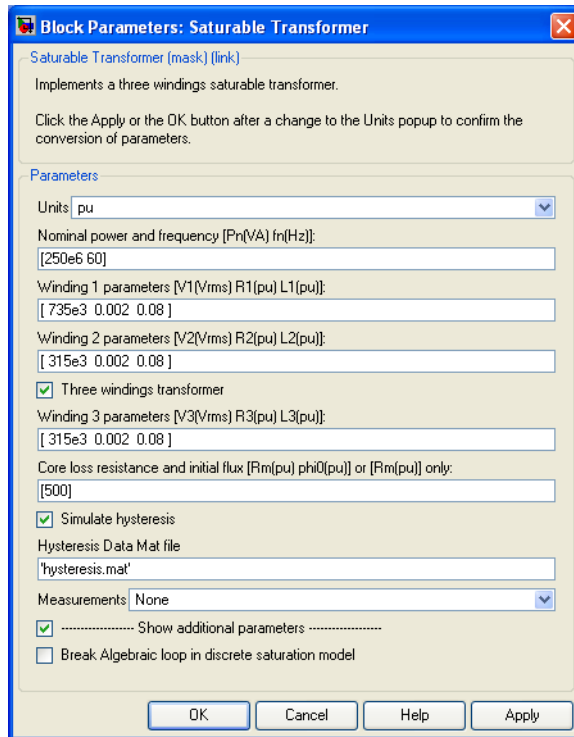

Units

Specify the units used to enter the parameters of the Saturable Transformer block. Select pu to use per unit. Select SI to use SI units. Changing the **Units** parameter from pu to SI, or from SI to pu, will automatically convert the parameters displayed in the mask of the block.

Nominal power and frequency

The nominal power rating, Pn, in volt-amperes (VA), and frequency, in hertz (Hz), of the transformer.

Winding 1 parameters

The nominal voltage in volts RMS, resistance in p.u. or Ohms, and leakage inductance in p.u. or Henrys for winding 1. Set the winding resistances and inductances to 0 to implement an ideal winding.

Saturable Transformer

Winding 2 parameters

The nominal voltage in volts RMS, resistance in p.u. or Ohms, and leakage inductance in p.u. or Henrys for winding 2. Set the winding resistances and inductances to 0 to implement an ideal winding.

Three windings transformer

If selected, specify a saturable transformer with three windings; otherwise it implements a two windings transformer.

Winding 3 parameters

The **Winding 3 parameters** are not available if the **Three windings transformer** parameter is not selected. The nominal voltage in volts RMS, resistance in p.u. or Ohms, and leakage inductance in p.u. or Henrys for winding 3. Set the winding resistances and inductances to 0 to implement an ideal winding.

Saturation characteristic

Specify a series of magnetizing current (p.u.) - flux (p.u.) pairs starting with (0,0).

Core loss resistance and initial flux

Specify the active power dissipated in the core by entering the equivalent resistance R_m in p.u. For example, to specify a 0.2% of active power core loss at nominal voltage, use $R_m = 500$ p.u. You can also specify the initial flux ϕ_0 (p.u). This initial flux becomes particularly important when the transformer is energized. If ϕ_0 is not specified, the initial flux is automatically adjusted so that the simulation starts in steady state. When simulating hysteresis, R_m models the eddy current losses only.

Simulate hysteresis

Select to model hysteresis saturation characteristic instead of a single-valued saturation curve.

Hysteresis data MAT file

The **Hysteresis data MAT file** parameter is visible only if the **Simulate hysteresis** parameter is selected.

Specify a .mat file containing the data to be used for the hysteresis model. When you open the **Hysteresis Design tool** of the Powergui, the default hysteresis loop and parameters saved in the hysteresis.mat file are

displayed. Use the **File** → **Load a model** menu of the **Hysteresis Design tool** to load another .mat file. Use the **File** → **Save this model** menu of the **Hysteresis Design tool** to save your model in a new .mat file.

Measurements

Select Winding voltages to measure the voltage across the winding terminals of the Saturable Transformer block.

Select Winding currents to measure the current flowing through the windings of the Saturable Transformer block.

Select Flux and excitation current ($I_m + I_{Rm}$) to measure the flux linkage, in volt seconds (V.s), and the total excitation current including iron losses modeled by R_m .

Select Flux and magnetization current (I_m) to measure the flux linkage, in volt seconds (V.s), and the magnetization current, in amperes (A), not including iron losses modeled by R_m .

Select All measurement (V, I, Flux) to measure the winding voltages, currents, magnetization currents, and the flux linkage.

Place a Multimeter block in your model to display the selected measurements during the simulation.

In the **Available Measurements** list box of the Multimeter block, the measurements are identified by a label followed by the block name.

Measurement	Label
Winding voltages	Uw1:, Uw2:, Uw3:
Winding currents	Iw1:, Iw2:, Iw3:
Excitation current	Iexc:
Magnetization current	Imag:
Flux linkage	Flux:

Limitations

Windings can be left floating (that is, not connected by an impedance to the rest of the circuit). However, the floating winding is connected internally to the

Saturable Transformer

main circuit through a resistor. This invisible connection does not affect voltage and current measurements.

Example

The power_xfosaturable demo illustrates the energization of one phase of a three-phase 450 MVA, 500/230 kV transformer on a 3000 MVA source. The transformer parameters are

Nominal power and frequency $P_n = 150e6$ VA $f_n = 60$ Hz

Winding 1 parameters (primary) $V_1 = 500e3$ Vrms/sqrt(3) $R_1 = 0.002$ p.u. $L_1 = 0.08$ p.u.

Winding 2 parameters (secondary) $V_2 = 230e3$ Vrms/sqrt(3) $R_2 = 0.002$ p.u. $L_2 = 0.08$ p.u.

Saturation characteristic [0 0; 0.0 1.2; 1.0 1.52]

Core loss resistance and initial flux $R_m = 500$ p.u. $\phi_{i0} = 0.8$ p.u.

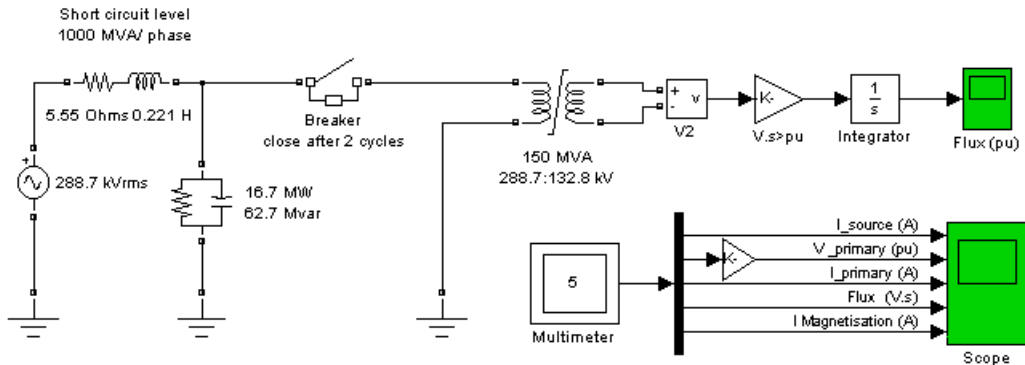

Simulation of this circuit illustrates the saturation effect on the transformer current and voltage.

As the source is resonant at the fourth harmonic, you can observe a high fourth-harmonic content in the secondary voltage. In this circuit, the flux is calculated in two ways:

- By integrating the secondary voltage
- By using the Multimeter block

The simulation results demonstrate these points:

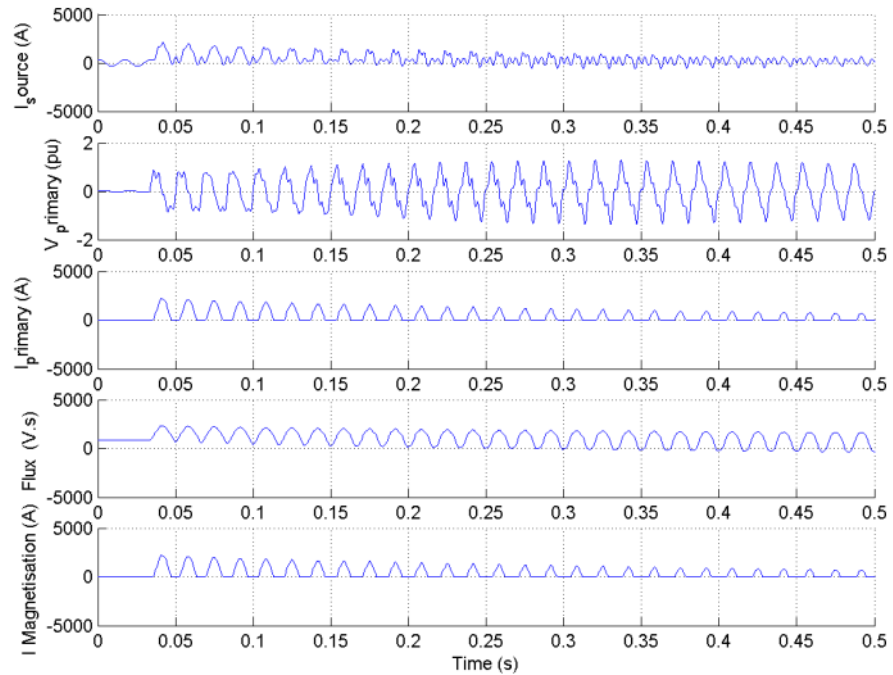

References

Casoria, S., P. Brunelle, and G. Sybille, "Hysteresis Modeling in the MATLAB/Power System Blockset," *Electrimacs 2002*, École de technologie supérieure, Montreal, 2002.

Frame, J.G., N. Mohan, and Tsu-huei Liu, "Hysteresis modeling in an Electro-Magnetic Transients Program," presented at the IEEE PES winter meeting, New York, January 31 to February 5, 1982.

Saturable Transformer

See Also

Linear Transformer, Multimeter, Mutual Inductance, Powergui, Three-Phase Transformer (Two Windings), Three-Phase Transformer (Three Windings)

Self-Controlled Synchronous Motor Drive

Purpose

Implement a Self-Controlled Synchronous Motor Drive

Library

Electric Drives/AC drives

Description

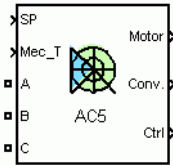

This block models a wound field synchronous motor (WFSM) vector control drive model. The high-level schematic shown below is built from six main blocks. The WFSM motor, the three-phase inverter, and the three-phase rectifier models are provided with the SimPowerSystems library. More details on these three blocks are available in the SimPowerSystems user guide. The speed controller, the rectifier controller, and the vector control models are specific to the drive library. It is possible to use a simplified version of the drive containing average-value models of the inverter and rectifier for faster simulation.

Note In SimPowerSystems, the Self-Controlled Synchronous Motor Drive block is commonly called the AC5 motor drive.

High-Level Schematic

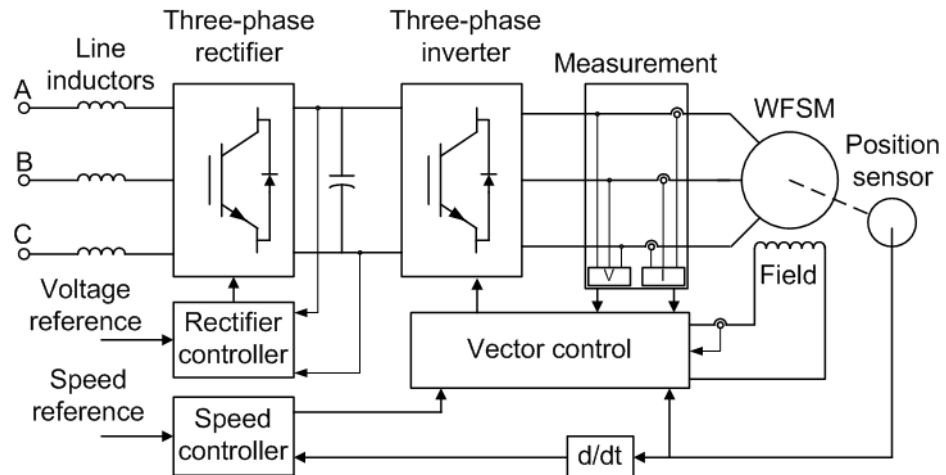

Self-Controlled Synchronous Motor Drive

Simulink Schematic

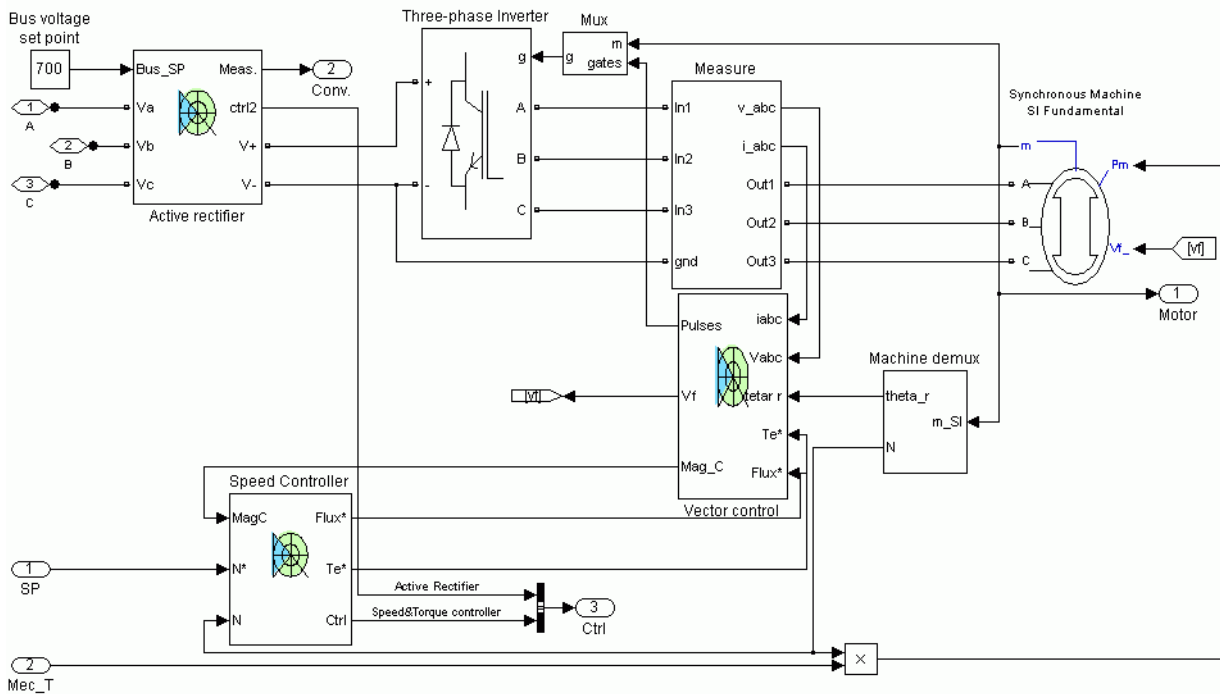

Speed Controller

The speed controller is based on a PI regulator, shown below. The outputs of this regulator are set points for the torque component of the current and for the flux applied to the vector control block.

Self-Controlled Synchronous Motor Drive

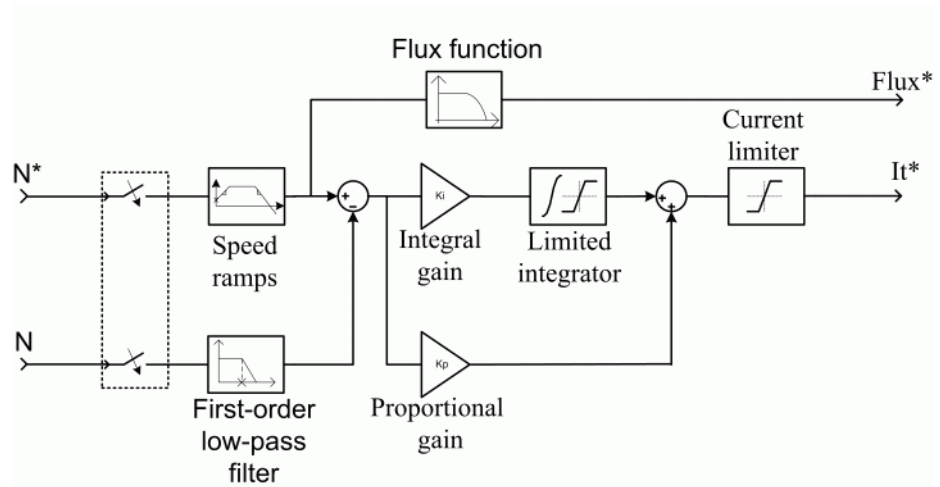

Rectifier Controller

The rectifier controller is based on a PI regulator of the DC bus voltage. The output of this regulator is the direct (active) component of the AC line current. The reactive component of the AC line current is set to zero in order to operate at unity power factor.

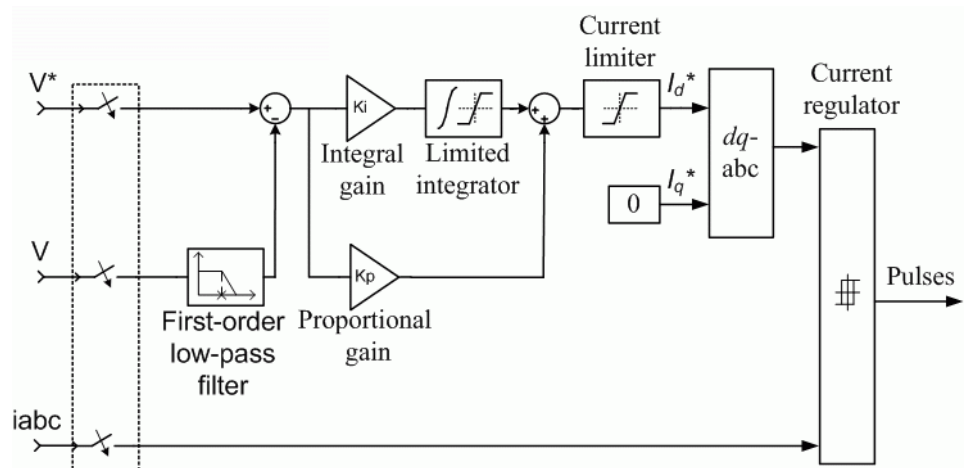

The *dq-abc* block performs the conversion of the *dq* current components into *abc* phase variables.

Self-Controlled Synchronous Motor Drive

The *current regulator* is a bang-bang current controller with adjustable hysteresis bandwidth.

Vector Controller

The vector control contains five main blocks shown in this figure. These blocks are described below.

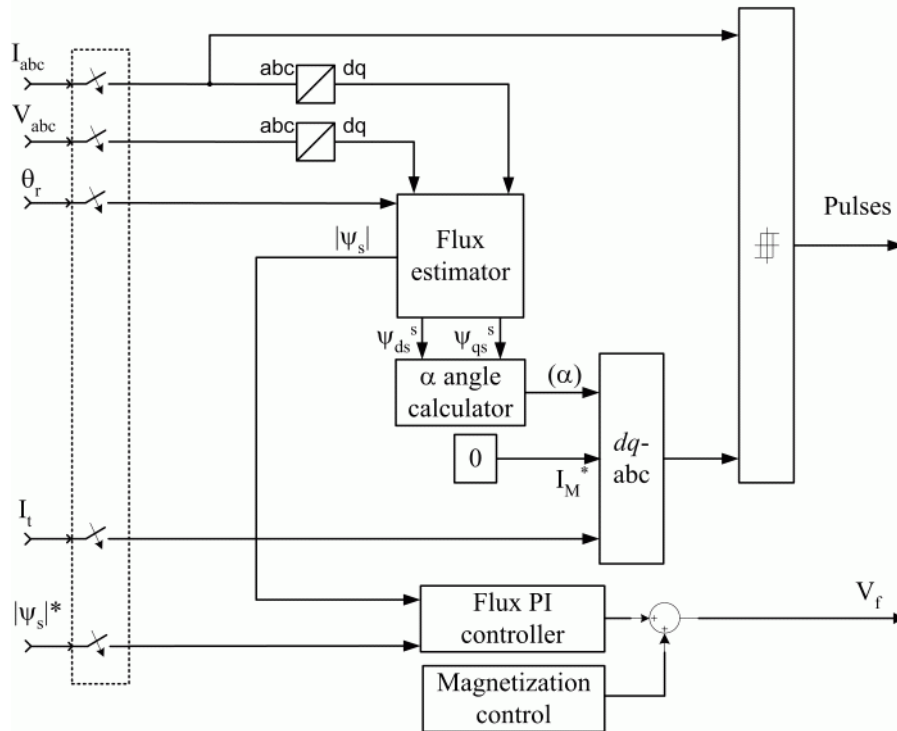

The *flux estimator* block is used to estimate the motor stator flux ψ_{dq}^s .

The *flux PI controller* is used to regulate the flux in the machine.

The *dq2abc* block performs the conversion of the *dq* current components into *abc* phase variables.

The *current regulator* is a bang-bang current controller with adjustable hysteresis bandwidth.

Self-Controlled Synchronous Motor Drive

The *magnetization control* unit contains the logic used to switch between the magnetization and normal operation mode.

Average-Value Inverter and Rectifier

The average-value inverter/rectifier internal architecture is shown in the following figure.

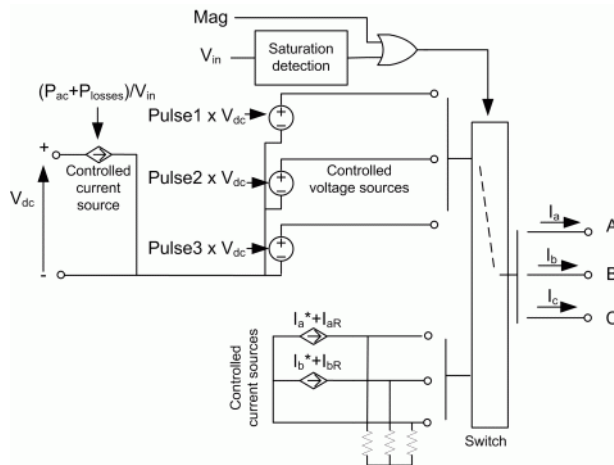

It is composed of one controlled current source on the DC side and of two controlled current sources and three controlled voltage sources on the AC side. The DC current source allows the representation of the average DC bus current behavior following the next equation:

$$I_{dc} = \frac{P_{ac} + P_{losses}}{V_{dc}}$$

with P_{ac} being the AC side instantaneous power, P_{losses} the losses in the power electronics devices and V_{in} the DC bus voltage.

On the AC side, the current sources represent the average phase currents fed to the motor. The regulation being fast, the current values are set equal to the current references sent by the current regulator. A small current is injected to compensate for the current drawn by the three-phase load (needed because of the inverter current sources in series with the inductive motor).

During loss of current tracking due to insufficient inverter voltage, the currents are fed by three controlled voltage sources. These voltage sources represent the square wave mode and allow good representation of the phase

Self-Controlled Synchronous Motor Drive

currents during inverter saturation. Each voltage source outputs either V_{in} or 0, depending on the values of the pulses (1 or 0) sent by the current controller.

Remarks

The model is discrete. Good simulation results have been obtained with a $2 \mu\text{s}$ time step. To simulate a digital controller device, the control system has two different sampling times:

- Speed controller sampling time
- Active rectifier controller and vector controller sampling time

The speed controller sampling time has to be a multiple of the vector controller sampling time. The latter sampling time has to be a multiple of the simulation time step. The average-value inverter and rectifier allow the use of bigger simulation time steps since they do not generate small time constants (due to the RC snubbers) inherent to the detailed converters. For a vector controller and active rectifier controller sampling time of $50 \mu\text{s}$, good simulation results have been obtained for a simulation time step of $50 \mu\text{s}$. This time step can, of course, not be higher than the smallest controller sampling time.

The torque sign convention of the synchronous machine is different from the one of the asynchronous and PM synchronous machines. That is, the synchronous machine is in the motor operation mode when the electric torque is negative and in the generator operation mode when the electric torque is positive.

Self-Controlled Synchronous Motor Drive

Dialog Box

Synchronous Machine Tab

The dialog box is titled "Self-Controlled Synchronous Motor Drive" and contains a description of the synchronous motor parameters. It is divided into three tabs: "Synchronous Machine", "Converters and DC Bus", and "Controller". The "Synchronous Machine" tab is active and displays the following parameters:

Electrical parameters

Nominal values

Power (VA):	Voltage (Vrms):	Frequency (Hz):	Field current (A):
149.2e3	460	60	1

Equivalent circuit values

	Resistance (ohm):	Leakage inductance (H):	Mutual inductance (H):
Stator:	2.01e-3	4.289e-4	
Field:	4.083e-4	0.429e-3	D-axis: 4.477e-3
D-axis dampers:	8.25e-3	0.685e-3	Q-axis: 1.354e-3
Q-axis dampers:	13.89e-3	1.44e-3	

Initial conditions

	Phase A current:	Phase B current:	Phase C current:	Field voltage (V):
Magnitude (A):	0	0	0	0
Phase (deg):	0	0	0	

Mechanical parameters

Rotor values

Inertia (kg·m ²):	15
Friction (N·m·s):	0.005
Pole pairs:	2

Initial values

Speed deviation (%):	-99.99
Angle (deg):	0

Model detail level: Detailed

Parameters file options: Load Save

OK Cancel Help Apply

The synchronous machine tab displays the parameters of the synchronous machine block of the powerlib library. Refer to the Synchronous Machine for more information on the synchronous machine parameters.

Self-Controlled Synchronous Motor Drive

Converters and DC bus tab

Self-Controlled Synchronous Motor Drive

The synchronous motor parameters are specified in the Machine tab. The line impedance, the DC bus capacitance, the active rectifier and the inverter switches parameters are specified in the Converters tab. Vector controller, active rectifier controller and speed controller parameters are specified in the controller tab.

Synchronous Machine **Converters and DC Bus** Controller

Rectifier

Switches

Device type: IGBT / Diodes

On-state resistance (ohm): 1e-3

Forward voltages (V)

Main device: 1.2

Diode: 1.2

Turn-off characteristics

Fall time (s): 1e-6

Tail time (s): 2e-6

Snubbers

Resistance (ohm): 4e3

Capacitance (F): 40e-9

DC Bus

Capacitance (F): 7500e-6

Input choke

Resistance (ohm): 0.05

Inductance (H): 1e-3

Inverter

Switches

Device type: IGBT / Diodes

On-state resistance (ohm): 1e-3

Forward voltages (V)

Main device: 1.2

Diode: 1.2

Turn-off characteristics

Fall time (s): 1e-6

Tail time (s): 2e-6

Snubbers

Resistance (ohm): 10e3

Capacitance (F): 10e-9

Model detail level: Detailed

Parameters file options

Load Save

OK Cancel Help Apply

Rectifier section

The rectifier section of the Converters and DC bus tab displays the parameters of the Universal Bridge block of the powerlib library. Refer to the Universal Bridge for more information on the universal bridge parameters.

Inverter section

The inverter section of the Converters and DC bus tab displays the parameters of the Universal Bridge block of the powerlib library. Refer to the Universal Bridge for more information on the universal bridge parameters.

Self-Controlled Synchronous Motor Drive

The average-value rectifier uses the three following parameters.

Source frequency

The frequency of the three-phase voltage source (Hz).

Source Voltage

The RMS line-to-line voltage of the three-phase voltage source (V).

On-state resistance

The on-state resistance of the rectifier devices (ohms).

The average-value inverter uses the two following parameters:

On-state resistance

The on-state resistance of the inverter devices (ohms).

Forward voltages [Device V_f , Diode V_{df}]

Forward voltages, in volts (V), of the forced-commutated devices and of the antiparallel diodes. These values are needed for startup and for square wave mode.

DC Bus Capacitance

The DC bus capacitance value (F).

Input Choke section

Input chokes reduce line current harmonics.

Resistance

The input choke resistance value (ohms).

Inductance

The input choke inductance value (H).

Self-Controlled Synchronous Motor Drive

Controller tab

The screenshot shows a software window titled "Self-Controlled Synchronous Motor Drive" with a "Controller" tab selected. The window contains several sections for configuring motor drive parameters:

- Regulation type:** A dropdown menu set to "Speed regulation".
- Speed Controller:** A sub-tab selected, containing:
 - Speed ramps (rpm/s):** Acceleration: 100, Deceleration: -100.
 - Current limits (A):** Minimum (negative): -1200, Maximum (positive): 1200.
 - PI regulator:** Proportional gain: 75, Integral gain: 100.
 - Speed cutoff frequency (Hz):** 5.
 - Speed controller sampling time (s):** 7×10^{-6} .
- DC Bus Controller:** A sub-tab that is currently inactive.
- Vector Controller:** A sub-tab that is currently inactive.
- Model detail level:** A dropdown menu set to "Detailed".
- Parameters file options:** Includes "Load" and "Save" buttons.
- Bottom buttons:** "OK", "Cancel", "Help", and "Apply".

Self-Controlled Synchronous Motor Drive

Regulation Type

This pop-up menu allows you to choose between speed and torque regulation.

Schematic Button

When you press this button, a diagram illustrating the speed, rectifier, and vector controllers schematics appears.

Controller — Speed controller Subtab

Speed Sensor Cutoff Frequency

The speed measurement first-order low-pass filter cutoff frequency (Hz).

Speed Controller Sampling Time

The speed controller sampling time (s). The sampling time must be a multiple of the simulation time step.

Speed Ramps — Acceleration

The maximum change of speed allowed during motor acceleration. An excessively large positive value can cause DC bus under-voltage (rpm/s).

Speed Ramps — Deceleration

The maximum change of speed allowed during motor deceleration. An excessively large negative value can cause DC bus over-voltage (rpm/s).

Proportional Gain

The speed controller proportional gain.

Integral Gain

The speed controller integral gain.

Current Output Limits — Negative

The maximum negative demanded current applied to the motor by the vector control (A).

Current Output Limits — Positive

The maximum positive demanded current applied to the motor by the vector control (A).

Self-Controlled Synchronous Motor Drive

Controller — DC Bus Controller Subtab

Self-Controlled Synchronous Motor Drive

The synchronous motor parameters are specified in the Machine tab. The line impedance, the DC bus capacitance, the active rectifier and the inverter switches parameters are specified in the Converters tab. Vector controller, active rectifier controller and speed controller parameters are specified in the controller tab.

Synchronous Machine | Converters and DC Bus | Controller

Regulation type : Speed regulation

Speed Controller | DC Bus Controller | Vector Controller

PI regulator

Line current d component limits (A)

Proportional gain: 10 Integral gain: 100 Minimum (negative): -800 Maximum (positive): 800

Voltage measurement cutoff frequency (Hz): 100 Active rectifier sampling time (s): 20e-6 Current hysteresis bandwidth (A): 10

Model detail level: Detailed

Parameters file options

Proportional Gain

The DC bus voltage controller proportional gain.

Integral Gain

The DC bus voltage controller integral gain.

Limits — Negative

The maximum current flowing from the DC bus capacitor towards the AC line (A).

Self-Controlled Synchronous Motor Drive

Limits — Positive

The maximum current flowing from the AC line towards the DC bus capacitor (A).

Voltage Measurement Low-Pass Filter

The bus voltage measurement low-pass filter cutoff frequency (Hz).

Sampling Time

The DC bus voltage controller sampling time (s). The sampling time must be a multiple of the simulation time step.

Current Hysteresis Bandwidth

The current hysteresis bandwidth. This value is the total bandwidth distributed symmetrically around the current set point (A). The following figure illustrates a case where the current set point is I_s^* and the current hysteresis bandwidth is set to dx .

This parameter is not used when using the average-value inverter.

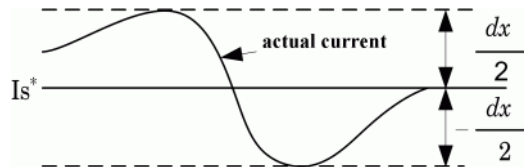

Self-Controlled Synchronous Motor Drive

Controller — Vector Controller Subtab

The screenshot shows the 'Self-Controlled Synchronous Motor Drive' software window. The 'Controller' tab is selected, and the 'Vector Controller' subtab is active. The interface includes a 'Regulation type' dropdown set to 'Speed regulation' and a 'Schematic' button. Below this, there are three sub-tabs: 'Speed Controller', 'DC Bus Controller', and 'Vector Controller'. The 'Flux controller' section contains a 'PI regulator' with 'Proportional gain' (100) and 'Integral gain' (0.1), and 'Voltage limits (V)' with 'Minimum' (-300) and 'Maximum' (300). A 'Flux estimation lowpass cutoff frequency (Hz)' is set to 2. The 'Magnetization controller' section includes 'Field magnetization voltage (V)' (600), 'High voltage field magnetization time (s)' (0.2), 'Field nominal voltage (V)' (30), and 'Total field magnetization time (s)' (1). Below these are 'Delta angle lowpass filter cutoff frequency (Hz)' (5), 'Controller sampling time (s)' (20e-6), 'Machine nominal flux (Wb)' (0.98), and 'Current hysteresis bandwidth (A)' (10). At the bottom, there is a 'Model detail level' dropdown set to 'Detailed', a 'Parameters file options' section with 'Load' and 'Save' buttons, and standard 'OK', 'Cancel', 'Help', and 'Apply' buttons.

Delta Angle Estimation Low-Pass Filter

The delta angle first-order filter cutoff frequency (Hz). Delta is the phase angle between the stator flux and the field flux. It is also called *power angle*.

Vector Controller Sampling Time

The vector controller sampling time (s). The sampling time must be a multiple of the simulation time step.

Motor Nominal Flux

The motor stator nominal flux (Wb).

Self-Controlled Synchronous Motor Drive

Flux Controller section

Proportional Gain

The flux controller proportional gain.

Integral Gain

The flux controller integral gain.

Voltage Limits — Minimum

The minimum voltage applied to the motor excitation field (V).

Voltage Limits — Maximum

The maximum voltage applied to the motor excitation field (V).

First-Order Low-Pass Cutoff Frequency

The flux estimation first-order filter cutoff frequency (Hz).

Magnetization Controller section

When you start the self-controlled synchronous motor, the magnetic flux of the motor must be first established before the motor is allowed to produce an electric torque. Since the motor field time constant is high, a field voltage much higher than nominal is applied in order to accelerate the building of the magnetic flux in the synchronous motor. After the period during which the high voltage is applied, the field voltage is lowered down to its nominal value during a second short period that adds to the latter period giving the total magnetization period. This procedure gives a smooth startup of the self-controlled synchronous motor.

Field Magnetization Voltage

The field magnetization voltage applied in order to establish the stator flux (V).

High voltage field magnetization time

The field magnetization high voltage application time (s).

Field Nominal Voltage

The field nominal voltage (V).

Total Magnetization Time

The total time before the drive is ready to produce a torque (s).

Self-Controlled Synchronous Motor Drive

Block Inputs and Outputs

SP

The speed or torque set point. Note that the speed set point can be a step function, but the speed change rate will follow the acceleration / deceleration ramps. If the load torque and the speed have opposite signs, the accelerating torque will be the sum of the electromagnetic and load torques.

Mec_T

The mechanical load torque input.

A, B, C

The three phase terminals of the motor drive.

Motor

The motor measurement vector. This vector allows you to observe the motor's variables using the Bus Selector block.

Conv

The three-phase converters measurement vector. This vector contains:

- The DC bus voltage
- The rectifier output current
- The inverter input current

Note that all current and voltage values of the bridges can be visualized with the Multimeter block.

Ctrl

The controller measurement vector. This vector contains the values for the active rectifier and for the inverter.

For the active rectifier:

- The active component of the current reference.
- The voltage error (difference between the DC bus voltage reference and actual DC bus voltage)
- The DC bus voltage reference

For the inverter:

- The torque reference
- The flux reference

Self-Controlled Synchronous Motor Drive

- The speed error (difference between the speed reference ramp and actual speed)
- The speed reference ramp or torque reference

Model Specifications

The library contains a 200 hp drive parameter set. The specifications of the 200 hp drive are shown in the following table.

200 HP Drive Specifications

Drive Input Voltage		
	Amplitude	460 V
	Frequency	60 Hz
Motor Nominal Values		
	Power	200 hp
	Speed	1800
	Voltage	460

Example

The ac5_example demo illustrates an AC5 motor drive simulation with standard load condition for the detailed and average-value models. At time $t = 0$ s, the speed set point is 300 rpm.

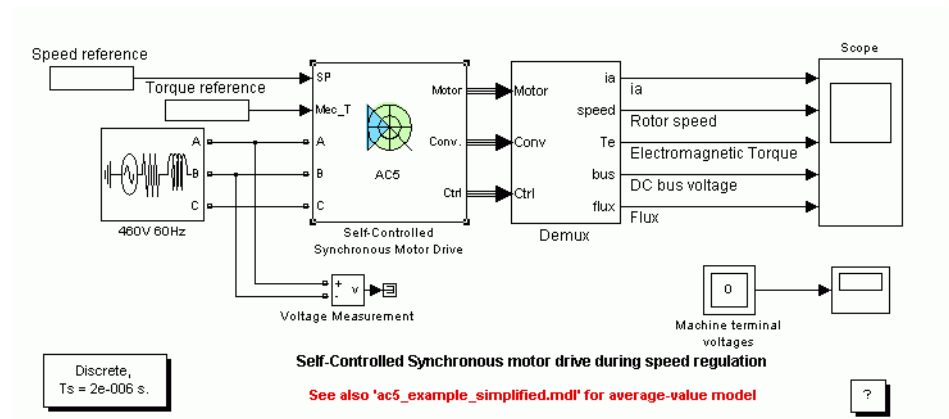

Self-Controlled Synchronous Motor Drive

As shown below, the speed precisely follows the acceleration ramp. At $t = 3$ s, the nominal load torque is applied to the motor. At $t = 4$ s, the speed set point is changed to 0 rpm. The speed decreases along the prescribed deceleration ramp to 0 rpm. At $t = 5.5$ s., the mechanical load passes from -792 N.m to 792 N.m. Notice that the results of the average-value model are similar to those of the detailed model except that the higher frequency signal components are not represented with the average-value converter.

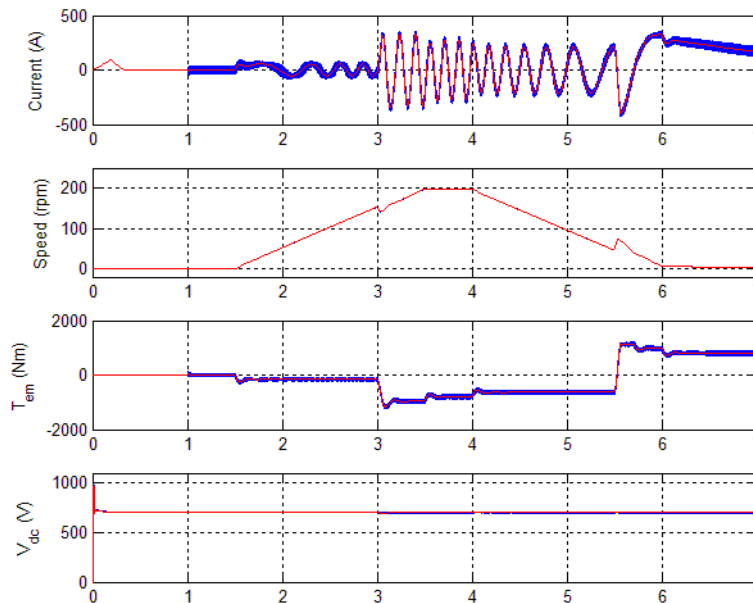

AC5 Example Waveforms (Blue : Detailed Converter, Red : Average-Value Converter)

References

- [1] Bose, B. K., *Modern Power Electronics and AC Drives*, Prentice-Hall, N.J., 2002.
- [2] Krause, P. C., *Analysis of Electric Machinery*, McGraw-Hill, 1986.

Purpose Implement a series RLC branch

Library Elements

Description The Series RLC Branch block implements a single resistor, inductor, or capacitor, or a series combination of these. To eliminate either the resistance, inductance, or capacitance of the branch, the R, L, and C values must be set respectively to 0, 0, and infinity (inf). Only existing elements are displayed in the block icon.



Negative values are allowed for resistance, inductance, and capacitance.

Dialog Box and Parameters

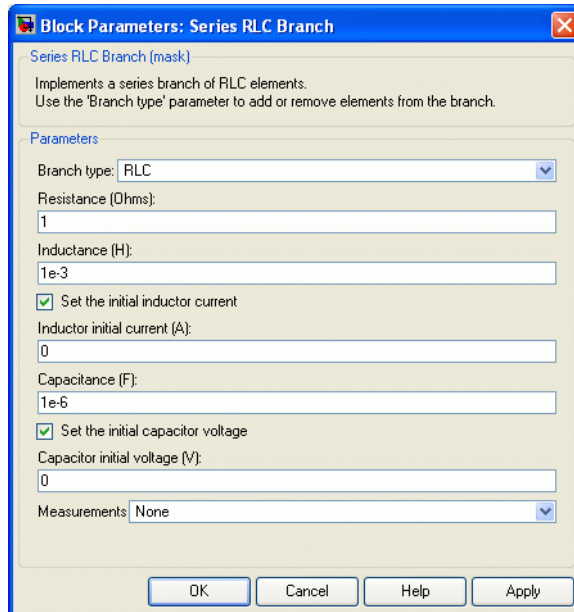

Branch type

Select the elements you want to include in the branch. The **R** letter defines the resistor, the **L** letter defines the inductor, and the **C** letter defines the capacitor.

Series RLC Branch

Resistance

The branch resistance, in ohms (Ω). The **Resistance** parameter is not visible if the resistor element is not specified in the **Branch type** parameter.

Inductance L

The branch inductance, in henries (H). The **Inductance** parameter is not visible if the inductor element is not specified in the **Branch type** parameter.

Set the initial inductor current

If selected, the initial inductor current is defined by the **Inductor initial current** parameter. If not selected, SimPowerSystems calculates the initial inductor current in order to start the simulation steady-state.

The **Set the initial inductor current** parameter is not visible and have no effect on the block if the inductor element is not specified in the **Branch type** parameter.

Inductor initial current (A)

The initial inductor current used at the start of the simulation. The **Inductor initial current** parameter is not visible and have no effect on the block if the inductor is not modeled and if the **Set the initial inductor current** parameter is not selected.

Capacitance C

The branch capacitance, in farads (F). The **Capacitance** parameter is not visible if the capacitance element is not specified in the **Branch type** parameter.

Set the initial capacitor voltage

If selected, the initial capacitor voltage is defined by the **Capacitor initial voltage** parameter. If not selected, SimPowerSystems calculates the initial capacitor voltage in order to start the simulation in steady-state.

The **Set the initial capacitor voltage** parameter is not visible and have no effect on the block if the capacitor element is not specified in the **Branch type** parameter.

Capacitor initial voltage (V)

The initial capacitor voltage used at the start of the simulation. The **Capacitor initial voltage** parameter is not visible and have no effect on the block if the capacitor is not modeled and if the **Set the initial capacitor voltage** parameter is not selected.

Measurements

Select Branch voltage to measure the voltage across the Series RLC Branch block terminals.

Select Branch current to measure the current flowing through the Series RLC Branch block.

Select Branch voltage and current to measure the voltage and the current of the Series RLC Branch block.

Place a Multimeter block in your model to display the selected measurements during the simulation. In the **Available Measurements** list box of the Multimeter block, the measurement is identified by a label followed by the block name.

Measurement	Label
Branch voltage	Ub :
Branch current	Ib :

Example

Obtain the frequency response of a fifth-harmonic filter (tuned frequency = 300 Hz) connected on a 60 Hz power system. This example is available in the power_seriesbranch model.

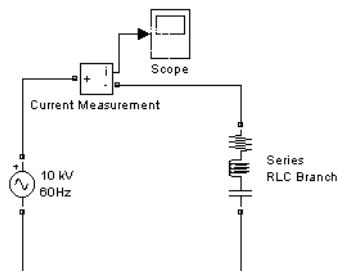

Series RLC Branch

The network impedance in the Laplace domain is

$$Z(s) = \frac{V(s)}{I(s)} = \frac{LCs^2 + RCs + 1}{Cs}$$

To obtain the frequency response of the impedance you have to get the state-space model (A B C D matrices) of the system.

This system is a one-input (Vsource) and one-output (Current Measurement block) system.

Note If you have the Control System Toolbox installed, you can use the bode function to get the transfer function $Z(s)$ from the state-space matrices as follows:

```
[A,B,C,D] = power_analyze('power_seriesbranch');
freq = logspace(1,4,500);
w = 2*pi*freq;
[Ymag,Yphase] = bode(A,B,C,D,1,w);
% invert Y(s) to get Z(s)
Zmag = 1./Ymag;
Zphase = -Yphase;
subplot(2,1,1)
loglog(freq,Zphase)
grid
title('5th harmonic filter')
xlabel('Frequency, Hz')
ylabel('Impedance Zmag')
subplot(2,1,2)
semilogx(freq,Zphase)
xlabel('Frequency, Hz')
ylabel('phase Z')
grid
```

You can also use the Impedance Measurement block and the Powergui block to plot the impedance as a function of frequency. In order to measure the impedance you must disconnect the voltage source.

Series RLC Branch

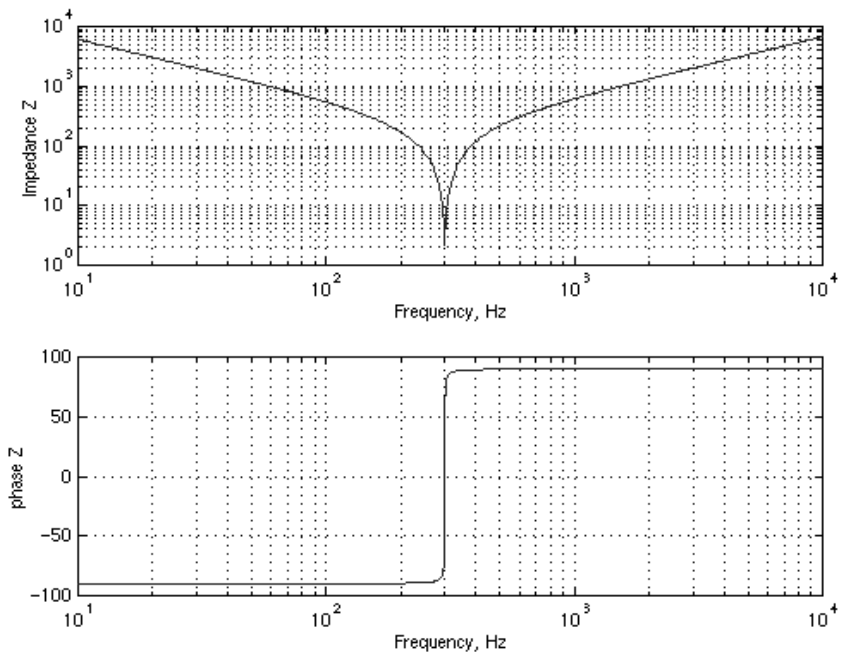

See Also

Multimeter, Parallel RLC Branch, Parallel RLC Load, Series RLC Load

Series RLC Load

Purpose Implement a linear series RLC load

Library Elements

Description The Series RLC Load block implements a linear load as a series combination of R L C elements. At the specified frequency, the load exhibits a constant impedance. The active and reactive powers absorbed by the load are proportional to the square of the applied voltage. Only elements associated with nonzero powers are displayed in the block icon.



Dialog Box and Parameters

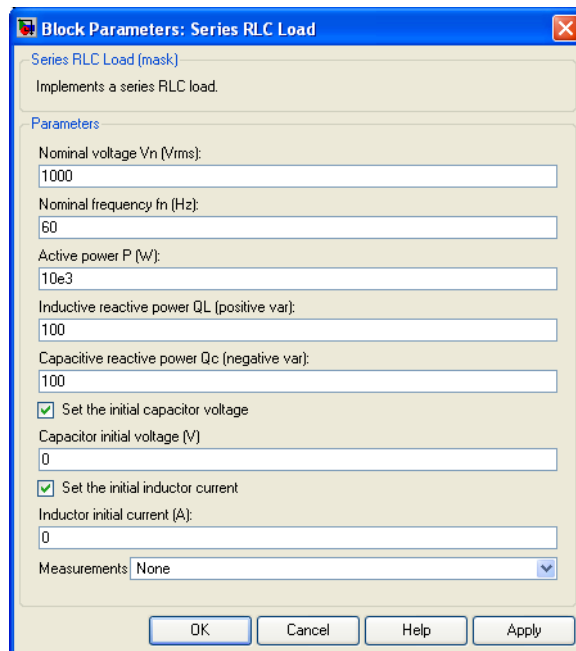

Nominal voltage V_n

The nominal voltage of the load, in volts RMS.

Nominal frequency f_n

The nominal frequency, in hertz.

Active power P

The active power of the load, in watts.

Inductive reactive power QL

The inductive reactive power QL, in vars. Specify a positive value, or 0.

Capacitive reactive power QC

The capacitive reactive power QC, in vars. Specify a positive value, or 0.

Set the initial capacitor voltage

If selected, the initial capacitor voltage is defined by the **Capacitor initial voltage** parameter. If not selected, SimPowerSystems calculates the initial capacitor voltage in order to start the simulation in steady-state.

The **Set the initial capacitor voltage** parameter have no effect on the block if the capacitive reactive power is equal to zero.

Capacitor initial voltage (V)

The initial capacitor voltage used at the start of the simulation. The **Capacitor initial voltage** parameter have no effect on the block if the capacitive reactive power is equal to zero and if the **Set the initial capacitor voltage** parameter is not selected.

Set the initial inductor current

If selected, the initial inductor current is defined by the **Inductor initial current** parameter. If not selected, SimPowerSystems calculates the initial inductor current in order to start the simulation steady-state.

The **Set the initial inductor current** parameter have no effect on the block if the inductive reactive power is equal to zero.

Inductor initial current (A)

The initial inductor current used at the start of the simulation. The **Inductor initial current** parameter have no effect on the block if the inductive reactive power is equal to zero and if the **Set the initial inductor current** parameter is not selected.

Measurements

Select Branch voltage to measure the voltage across the Series RLC Load block terminals.

Series RLC Load

Select **Branch current** to measure the current flowing through the Series RLC Load block.

Select **Branch voltage** and **current** to measure the voltage and the current of the Series RLC Load block.

Place a **Multimeter** block in your model to display the selected measurements during the simulation. In the **Available Measurements** list box of the **Multimeter** block, the measurement is identified by a label followed by the block name:

Measurement	Label
Branch voltage	Ub:
Branch current	Ib:

Example

The power_seriesload demo uses a Series RLC Load block to implement a simple load.

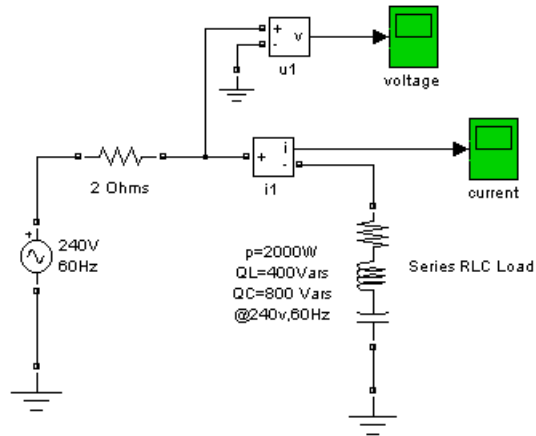

See Also

Multimeter, Parallel RLC Branch, Parallel RLC Load, Series RLC Branch

Simplified Synchronous Machine

Purpose

Model the dynamics of a simplified three-phase synchronous machine

Library

Machines

Description

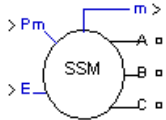

The Simplified Synchronous Machine block models both the electrical and mechanical characteristics of a simple synchronous machine.

The electrical system for each phase consists of a voltage source in series with an RL impedance, which implements the internal impedance of the machine. The value of R can be zero but the value of L must be positive.

The Simplified Synchronous Machine block implements the mechanical system described by

$$\Delta\omega(t) = \frac{1}{2H} \int_0^t (T_m - T_e) dt - Kd\Delta\omega(t)$$
$$\omega(t) = \Delta\omega(t) + \omega_0$$

where

$\Delta\omega$ = Speed variation with respect to speed of operation

H = Constant of inertia

T_m = Mechanical torque

T_e = Electromagnetic torque

Kd = Damping factor representing the effect of damper windings

$\omega(t)$ = Mechanical speed of the rotor

ω_0 = Speed of operation (1 p.u.)

Although the parameters can be entered in either SI units or per unit in the dialog box, the internal calculations are done in per unit. The following block diagram illustrates how the mechanical part of the model is implemented. Notice that the model computes a deviation with respect to the speed of operation, and not the absolute speed itself.

Simplified Synchronous Machine

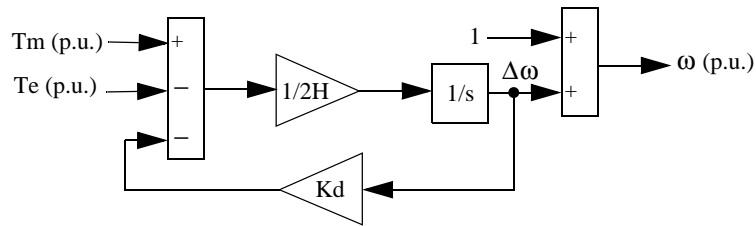

The K_d damping coefficient simulates the effect of damper windings normally used in synchronous machines. When the machine is connected to an infinite network (zero impedance), the variation of machine power angle δ resulting from a change of mechanical power (P_m) can be approximated by the following second-order transfer function:

$$\delta/P_m = (\omega_s/2H)/(s^2 + 2\zeta\omega_n s + \omega_n^2)$$

where

- δ Power angle delta: angle of internal voltage E with respect to terminal voltage, in radians
- P_m Mechanical power in p.u.
- ω_n Frequency of electromechanical oscillations = $\sqrt{\omega_s \cdot P_{max}/(2H)}$ in rad/s
- ζ Damping ratio = $(K_d/4)\sqrt{2/(\omega_s \cdot H \cdot P_{max})}$
- ω_s Electrical frequency in rad/s
- P_{max} Maximum power in p.u. transmitted through reactance X at terminal voltage V_t and internal voltage E . $P_{max} = V_t \cdot E/X$ (p.u.) where V_t , E , and X are in p.u.
- H Inertia constant(s)
- K_d Damping factor (p.u._of_torque / p.u._of_speed)

Simplified Synchronous Machine

This approximate transfer function, which has been derived by assuming $\sin(\delta) = \delta$, is valid for small power angles ($\delta < 30$ degrees). It follows from the above ζ expression that the K_d value required to obtain a given ζ damping ratio is

$$K_d = 4\zeta\sqrt{\omega_s \cdot H \cdot P_{max}/2}$$

Dialog Box and Parameters

In the **powerlib** library you can choose between the SI units or the p.u. units Simplified Synchronous Machine blocks to specify the electrical and mechanical parameters of the model.

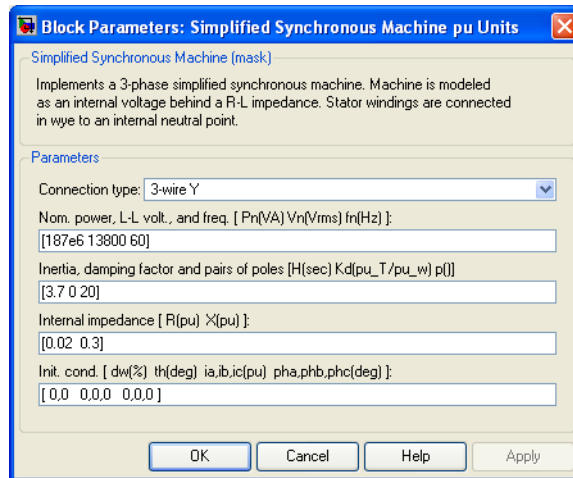

Connection type

Specify the number of wires used in three-phase Y connection: either three-wire (neutral not accessible) or four-wire (neutral is accessible).

Nominal power, L-L voltage, and frequency

The nominal apparent power P_n (VA), frequency f_n (Hz), and RMS line-to-line voltage V_n (V). Used to compute nominal torque and convert SI units to p.u.

Inertia, friction factor and pairs of poles

The inertia (J in $\text{kg}\cdot\text{m}^2$ or H in seconds) damping factor (K_d) and number of pairs of poles (p). The damping factor should be specified in (p.u. of torque)/(p.u. of speed) in both machine dialog boxes (in p.u. and in SI).

Simplified Synchronous Machine

Internal impedance

The resistance R (Ω or p.u.) and reactance L (H or p.u.) for each phase.

Initial conditions

The initial speed deviation (% of nominal), rotor angle (degrees), line current magnitudes (A or p.u.), and phase angles (degrees). These values can be computed by the load flow utility of the Powergui block.

Note These two blocks simulate exactly the same simplified synchronous machine model; the only difference is the way of entering the parameter units.

Inputs and Outputs

P_m

The mechanical power supplied to the machine. The input can be a constant signal or it can be connected to the output of the Hydraulic Turbine and Governor block. The frequency of the internal voltage sources depends on the mechanical speed of the machine.

E

The amplitude of the internal voltages of the block. It can be a constant signal or it can be connected to the output of a voltage regulator. If you use the SI units machine, these two inputs should be in watts and volts phase-to-phase RMS. If you use the p.u. units machine, both inputs should be in p.u.

m

The Simulink output of the block is a vector containing 12 signals. You can demultiplex these signals by using the Bus Selector block provided in the Simulink library.

Signal	Definition	Units	Symbol
1	Stator current i_{s_a}	A or p.u.	i_{s_a}
2	Stator current i_{s_b}	A or p.u.	i_{s_b}
3	Stator current i_{s_c}	A or p.u.	i_{s_c}
4	Terminal voltage V_a	V or p.u.	v_a

Simplified Synchronous Machine

Signal	Definition	Units	Symbol
5	Terminal voltage Vb	V or p.u.	v_b
6	Terminal voltage Vc	V or p.u.	v_c
7	Internal voltage Ea	V or p.u.	E_a
8	Internal voltage Eb	V or p.u.	E_b
9	Internal voltage Ec	V or p.u.	E_c
10	Rotor angle theta	rad	θ
11	Rotor speed ω_m	rad/s	ω
12	Electrical power Pe	W	P_e

Assumptions

The electrical system of the Simplified Synchronous Machine block consists solely of a voltage source behind a synchronous reactance and resistance. All the other self- and magnetizing inductances of the armature, field, and damping windings are neglected. The effect of damper windings is approximated by the damping factor K_d . The three voltage sources and RL impedance branches are Y-connected (three wires or four wires). The load might or might not be balanced.

Limitations

When you use Simplified Synchronous Machine blocks in discrete systems, you might have to use a small parasitic resistive load, connected at the machine terminals, in order to avoid numerical oscillations. Large sample times require larger loads. The minimum resistive load is proportional to the sample time. As a rule of thumb, remember that with a 25 ms time step on a 60 Hz system, the minimum load is approximately 2.5% of the machine nominal power. For example, a 200 MVA simplified synchronous machine in a power system discretized with a 50 ms sample time requires approximately 5% of resistive load or 10 MW. If the sample time is reduced to 20 ms, a resistive load of 4 MW should be sufficient.

Example

The `power_simplealt` demo uses the Simplified Synchronous Machine block to represent a 1000 MVA, 315 kV, 60 Hz equivalent source connected to an infinite bus (Three-Phase Programmable Voltage Source block). The Simplified Synchronous Machine (SI Units) block is used as a synchronous generator. The

Simplified Synchronous Machine

internal resistance and reactance are set respectively to 0.02 p.u. (1.9845 Ω) and 0.2 p.u. ($X = 19.845 \Omega$; $L = 0.0526$ H). The inertia of the machine is $J = 168,870 \text{ kg}\cdot\text{m}^2$, corresponding to an inertia constant $H = 3$ s. The electrical frequency is $\omega_s = 2\pi \cdot 60/2 = 377$ rad/s. The machine has two pairs of poles such that its synchronous speed is $2\pi \cdot 60/2 = 188.5$ rad/s or 1800 rpm.

The **Load Flow** option of the Powergui has been used to initialize the machine in order to start simulation in steady state with the machine generating 500 MW. The required internal voltage computed by the load flow is 1.0149 p.u. Therefore an internal voltage $E = 315e3 \cdot 1.0149 = 319,690$ V_{rms} phase-to-phase is specified in the Constant block connected to the E input. The maximum power that can be delivered by the machine with a terminal voltage $V_t = 1.0$ p.u. and an internal voltage $E = 1.0149$ p.u. is $P_{\max} = V_t \cdot E / X = 1.0149/0.2 = 5.0745$ p.u.

The damping factor K_d is adjusted in order to obtain a damping ratio $\zeta = 0.3$. According to the formula given in the Description section, the required K_d value is

$$K_d = 4\zeta \sqrt{(\omega_s \cdot H \cdot P_{\max})/2} = 64.3$$

Two Fourier blocks are used to measure the power angle δ . This angle is computed as the difference between the phase angle of phase A internal voltage and the phase angle of phase A terminal voltage.

Simplified Synchronous Machine

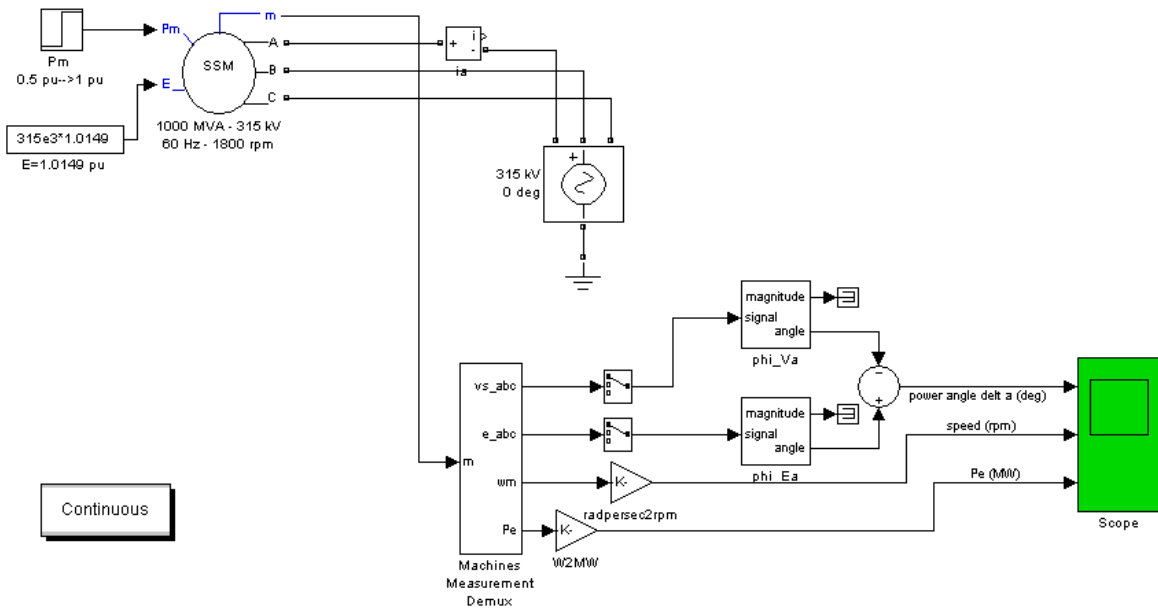

Simplified Synchronous Machine

In this demo, a step is performed on the mechanical power applied to the shaft. The machine is initially running in steady state with a mechanical power of 505 MW (mechanical power required for an output electrical power of 500 MW, considering the resistive losses). At $t = 0.5$ s the mechanical power is suddenly increased to 1000 MW.

Run the demo and observe the electromechanical transient on the Scope block displaying the power angle δ in degrees, the machine speed in rpm, and the electrical power in MW. Simulation results are shown in the following figure.

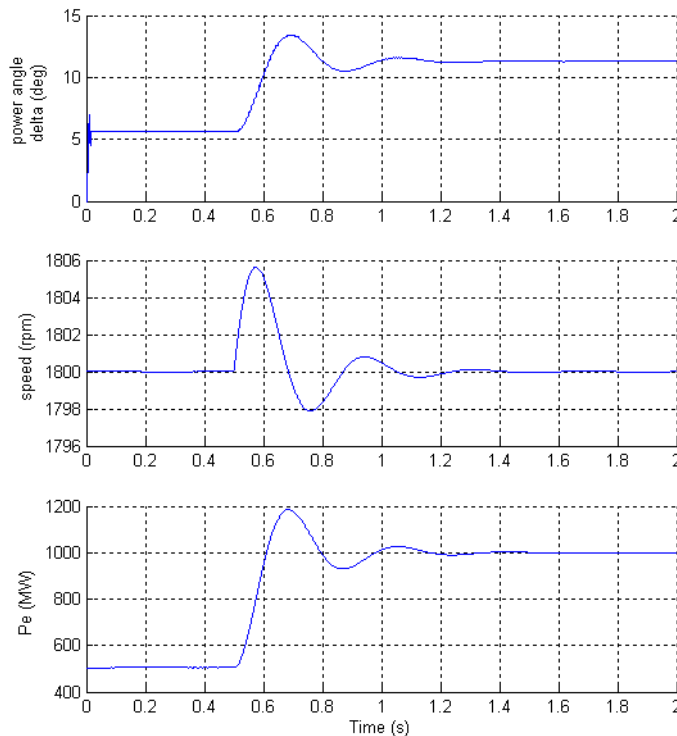

For an initial electrical power $P_e = 500$ MW (0.5 p.u.), the load angle δ is 5.65 degrees, which corresponds to the expected value:

$$P_e = \frac{V_t \cdot E \cdot \sin \delta}{X} = \frac{1.0 \cdot 1.0149 \cdot \sin(5.65^\circ)}{0.2} = 0.5 \text{ p.u.}$$

Simplified Synchronous Machine

As the mechanical power is stepped from 0.5 p.u. to 1.0 p.u., the load angle increases and goes through a series of under damped oscillations (damping ratio $\zeta = 0.3$) before stabilizing to its new value of 11.3 degrees. The frequency of the oscillations is given by

$$f_n = (1/2\pi) \cdot \sqrt{\omega_s \cdot P_{max} / (2H)} = 2.84 \text{ Hz}$$

See Also

Excitation System, Hydraulic Turbine and Governor, Powergui, Steam Turbine and Governor, Synchronous Machine

Single Phase Asynchronous Machine

Purpose

Model the dynamics of a single phase asynchronous machine with squirrel-cage rotor.

Library

Machines

Description

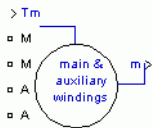
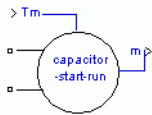
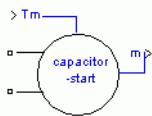
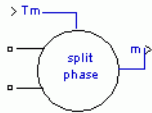

This machine has two windings: the main winding and the auxiliary winding. The model allows to simulate the split-phase, the capacitor-start, the capacitor-start-capacitor-run, and main & auxiliary windings operation modes.

The electrical part of the machine is represented by a fourth-order state-space model and the mechanical part by a second-order system. All electrical variables and parameters are referred to the stator. This is indicated by the prime signs in the machine equations given below. All stator and rotor quantities are in the stator reference frame (dq frame). The subscripts used are defined as follows:

Subscript	Definition
d	d axis quantity
q	q axis quantity
r	Referred to the main winding rotor quantity
R	Referred to the auxiliary winding rotor quantity
s	Main winding stator quantity
S	Auxiliary winding stator quantity
l	Leakage inductance
m	Magnetizing inductance

Single Phase Asynchronous Machine

Electrical System

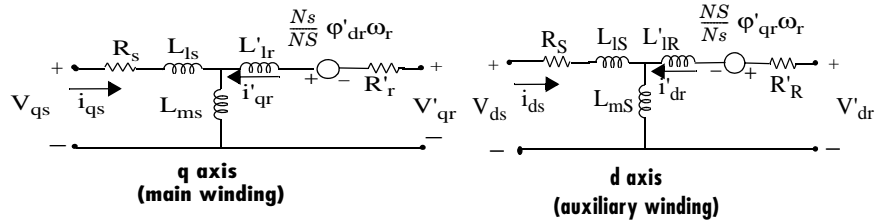

$$V_{qs} = R_s i_{qs} + \frac{d}{dt} \phi_{qs}$$

$$V_{ds} = R_s i_{ds} + \frac{d}{dt} \phi_{ds}$$

$$V'_{qr} = R'_r i'_{qr} + \frac{d}{dt} \phi'_{qr} - \frac{N_s}{N_s} \omega_r \phi'_{dr}$$

$$V'_{dr} = R'_r i'_{dr} + \frac{d}{dt} \phi'_{dr} + \frac{N_s}{N_s} \omega_r \phi'_{qr}$$

$$T_e = p \left(\frac{N_s}{N_s} \phi'_{qr} i'_{dr} - \frac{N_s}{N_s} \phi'_{dr} i'_{qr} \right)$$

$$\phi_{qs} = L_{ss} i_{qs} + L_{ms} i'_{qr}$$

$$\phi_{ds} = L_{SS} i_{ds} + L_{mS} i'_{dr}$$

$$\phi'_{qr} = L'_{rr} i'_{qr} + L_{ms} i_{qs}$$

$$\phi'_{dr} = L'_{RR} i'_{dr} + L_{mS} i_{ds}$$

$$L_{ss} = L_{ls} + L_{ms}$$

$$L_{SS} = L_{lS} + L_{mS}$$

$$L'_{rr} = L'_{lr} + L_{ms}$$

$$L'_{RR} = L'_{lR} + L_{mS}$$

where

Mechanical System

$$\frac{d}{dt} \omega_m = \frac{1}{2H} (T_e - F \omega_m - T_m)$$

$$\frac{d}{dt} \theta_m = \omega_m$$

Reference frame

The reference frame fixed in the stator is used to convert voltages and currents to the dq frame.

The following relationships describe the ab-to-dq frame transformations applied to the single phase asynchronous machine.

Single Phase Asynchronous Machine

$$\begin{bmatrix} f_{qs} \\ f_{ds} \end{bmatrix} = \begin{bmatrix} 1 & 0 \\ 0 & -1 \end{bmatrix} \begin{bmatrix} f_{as} \\ f_{bs} \end{bmatrix}$$

$$\begin{bmatrix} f_{qr} \\ f_{dr} \end{bmatrix} = \begin{bmatrix} \cos \theta_r & -\sin \theta_r \\ -\sin \theta_r & -\cos \theta_r \end{bmatrix} \begin{bmatrix} f_{ar} \\ f_{br} \end{bmatrix}$$

The variable f can represent either voltage, currents or flux linkage.

The single phase asynchronous machine block parameters are defined as follows (all quantities are referred to the stator):

Parameter	Definition
R_s, L_{ls}	Main winding stator resistance and leakage inductance
R_S, L_{lS}	Auxiliary winding stator resistance and leakage inductance
R'_r, L'_{lr}	Main winding rotor resistance and leakage inductance
R'_R, L'_{lR}	Auxiliary winding rotor resistance and leakage inductance
L_{ms}	Main winding magnetizing inductance
L_{mS}	Auxiliary winding magnetizing inductance
L_{ss}, L'_{rr}	Total main winding stator and rotor inductances
L_{SS}, L'_{RR}	Total auxiliary winding stator and rotor inductances
V_{as}, i_{as}	Main winding stator voltage and current
V_{bs}, i_{bs}	Auxiliary winding stator voltage and current
V_{qs}, i_{qs}	q axis stator voltage and current
V'_{qr}, i'_{qr}	q axis rotor voltage and current
V_{ds}, i_{ds}	d axis stator voltage and current
V'_{dr}, i'_{dr}	d axis rotor voltage and current

Single Phase Asynchronous Machine

Parameter	Definition (Continued)
Φ_{qs}, Φ_{ds}	Stator q and d axis fluxes
Φ'_{qr}, Φ'_{dr}	Rotor q and d axis fluxes
ω_m	Angular velocity of the rotor
θ_m	Rotor angular position
p	Number of pole pairs
ω_r	Electrical angular velocity ($\omega_m \times p$)
θ_r	Electrical rotor angular position ($\theta_m \times p$)
T_e	Electromagnetic torque
T_m	Shaft mechanical torque
J	Combined rotor and load inertia coefficient in (kg.m^2). Set to infinite to simulate locked rotor.
F	Combined rotor and load viscous friction coefficient
H	Combined rotor and load inertia constant in (s). Set to infinite to simulate locked rotor.
N_s	Number of main winding's effective turns
N_S	Number of auxiliary winding's effective turns
R_{st}	Capacitor-Start resistance
C_s	Capacitor-Start
R_{run}	Capacitor-Run resistance
C_{run}	Capacitor-Run
N	Ratio of number of auxiliary winding's effective turns and number of main winding's effective turns

Single Phase Asynchronous Machine

Dialog Box and Parameters

You can choose between two types of unit to specify the electrical and mechanical parameters of the model, the per-unit dialog box and the SI dialog box. Both blocks are modeling the same machine. Depending on the dialog box you choose to use, SimPowerSystems automatically converts the parameters you enter into per unit parameters. The Simulink model of the single phase asynchronous machine block uses per unit parameters.

Block Parameters: Single Phase Asynchronous Machine

Single Phase Asynchronous Machine (mask) (link)

Implements a single phase asynchronous machine (split-phase, capacitor-start, capacitor-start-run, main and auxiliary windings accessible) modeled in the dq stator reference frame.
Main and auxiliary windings are in quadrature.
You can specify initial speed that will make the machine run without the auxiliary winding.

Click the Apply or the OK button after a change to the Units popup to confirm the conversion of parameters.

Parameters

Units: SI

Type of machine: Capacitor-Start-Run

Nominal power, voltage, and frequency [Pn(VA), Vn(Vrms), f(HZ)]
[.25 746 110 60]

Main winding stator [Rs(ohm), Lls(H)]
[2.02 7.4e-3]

Main winding rotor [Rr(ohm), Llr(H)]
[4.12 5.6e-3]

Main winding mutual inductance Lms(H)
0.1772

Auxiliary winding stator [RS(ohm), LIS(H)]
[7.14 8.5e-3]

Inertia, friction factor, pairs of poles, ratio of turns [J(kg.m²), F(N.m.s), p, N]
[0.0146 0 2 1.18]

Capacitor-Start [Rst(ohm), Cst(farad)]
[2 254.7e-6]

Capacitor-Run [Rru(ohm), Cru(farad)]
[18 21.1e-6]

Disconnection speed wc (% synchronous speed)
75

Initial speed w0 (% synchronous speed)
0

OK Cancel Help Apply

Units

Specifies the per unit dialog box or the SI dialog box.

Single Phase Asynchronous Machine

Type of single phase asynchronous machine

Specifies the four type of single phase asynchronous machine (the split-phase, the capacitor-start, the capacitor-start-capacitor-run, and the main & auxiliary windings).

Nominal power, volt, and freq.

The nominal apparent power P_n (VA), RMS V_n (V), and frequency f_n (Hz).

Main winding stator

The stator resistance R_s (Ω or p.u.) and leakage inductance L_{ls} (H or p.u.).

Main winding rotor

The rotor resistance R_r' (Ω or p.u.) and leakage inductance L_{lr}' (H or p.u.), both referred to the stator.

Auxiliary winding stator

The stator resistance R_s (Ω or p.u.) and leakage inductance L_{ls} (H or p.u.).

Main winding mutual inductance

The magnetizing inductance L_{ms} (H or p.u.).

Inertia, friction factor, and pairs of poles

For the **SI units** dialog box: the combined machine and load inertia coefficient J (kg.m^2), combined viscous friction coefficient F (N.m.s), number of pole pairs p and ratio of number of auxiliary winding's effective turns and number of main winding's effective turns **p.u. units** dialog box: the inertia constant H (s), combined viscous friction coefficient F (p.u.), and number of pole pairs p .

Capacitor-Start

The start capacitance C_s (farad or p.u) and capacitor series resistance R_{st} (Ω or p.u.)

Capacitor-Run

The run capacitance C_{run} (farad or p.u) and series resistance R_{run} (farad or p.u)

Disconnection speed

Specifies the speed (%) when the auxiliary winding may be disconnected.

Initial speed

Single Phase Asynchronous Machine

Specifies the initial speed (%).

Inputs and Outputs

Tm

The Simulink input of the block is the mechanical torque at the machine's shaft. When you use the SI parameters mask, the input is a signal in N.m, otherwise it is in p.u.

m

The Simulink output of the block is a vector containing 16 signals. You can demultiplex these signals by using the Bus Selector block provided in the Simulink library. Depending on the type of mask you use, the units are in SI, or in p.u.

Signal	Definition	Units	Symbol
1	Rotor current ir_a	A or p.u.	i'_{ra}
2	Rotor current ir_b	A or p.u.	i'_{rb}
3	Rotor current iq	A or p.u.	i'_{qr}
4	Rotor current id	A or p.u.	i'_{dr}
5	Rotor flux phir_q	V.s or p.u	ϕ'_{qr}
6	Rotor flux phir_d	V.s or p.u	ϕ'_{dr}
7	Rotor voltage Vr_q	V or p.u	v'_{qr}
8	Rotor voltage Vr_d	V or p.u	v'_{d}
9	Main winding stator current ia	A or p.u.	i_a
10	Auxiliary winding stator current ib	A or p.u.	i_b
11	Voltage capacitor Vc	V or p.u.	V_c
12	Stator flux phis_q(V.s)	V.s or p.u.	ϕ_{qs}
13	Stator flux phis_d(V.s)	V.s or p.u.	ϕ_{ds}

Single Phase Asynchronous Machine

Signal	Definition	Units	Symbol
14	Rotor speed	rad/s	ω_m
15	Electromagnetic torque T_e	N.m or p.u.	T_e
16	Rotor angle θ_m	rad	θ_m

Limitations

The single phase asynchronous machine block does not include a representation of iron losses and saturation.

Example

This example, available in the `power_singlephaseASM.mdl` file, illustrates the use of the Single Phase Asynchronous Machine block in two modes of operation.

It consists of a single phase asynchronous machine in an open-loop speed control system. The main and auxiliary windings are fed by a single phase power supply. The motor is started at no-load and a step of 1N.m is applied at 2 seconds.

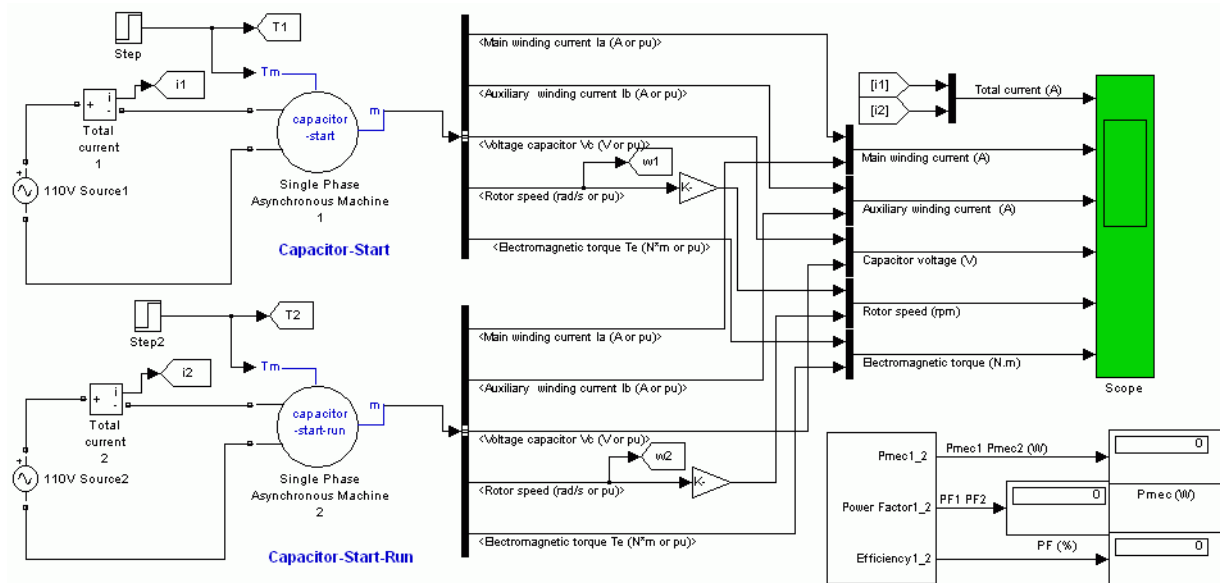

Single Phase Asynchronous Machine

Capacitor-Start Operation Mode

The next series of figures shows the capacitor-start operation where the auxiliary winding is tripped when the machine is speeded up to 75% of the rated speed.

The last figure in the series, “Electromagnetic Torque in Capacitor-Start Operation Mode” on page 7-395, shows the electromagnetic torque developed by the machine. Since there is a step load of 1 N.m, the average torque will be 1 N.m. The torque ripple amplitude is about 2.5 N.m, or 150% of the rated load. The torque pulsation affects the operation of the machine.

The auxiliary winding current is set to zero when the speed reaches 75% of the rated speed. The voltage across the start-capacitor remains at its maximum value, since current and voltage across a capacitor are in quadrature.

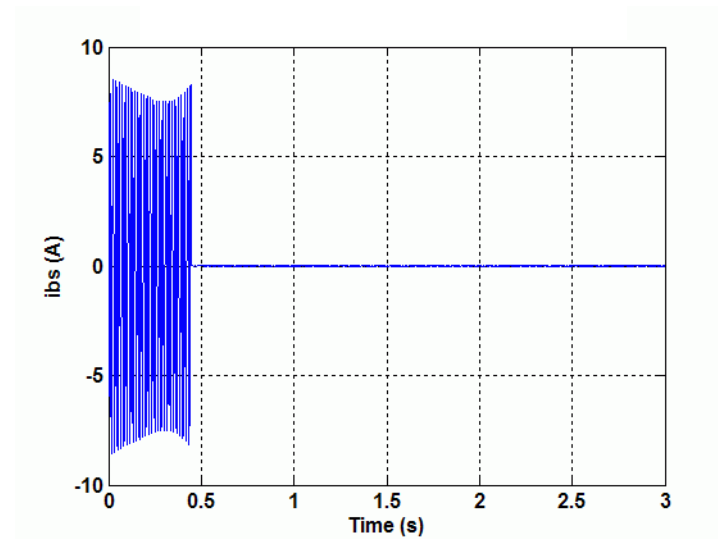

Auxiliary Winding Current in Capacitor-Start Operation Mode

Single Phase Asynchronous Machine

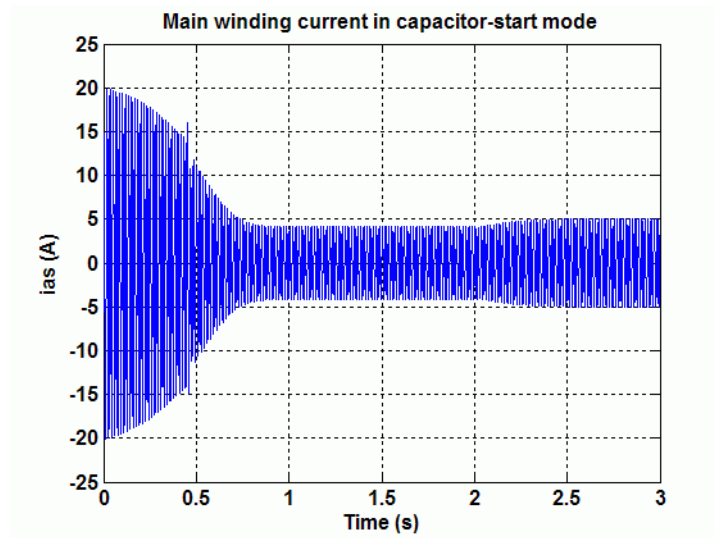

Main Winding Current in Capacitor-Start Operation Mode

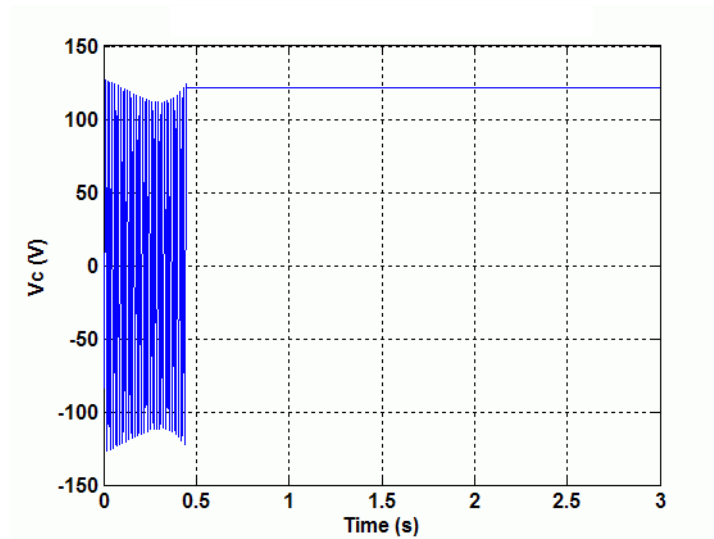

Capacitor Voltage in Capacitor-Start Operation Mode

Single Phase Asynchronous Machine

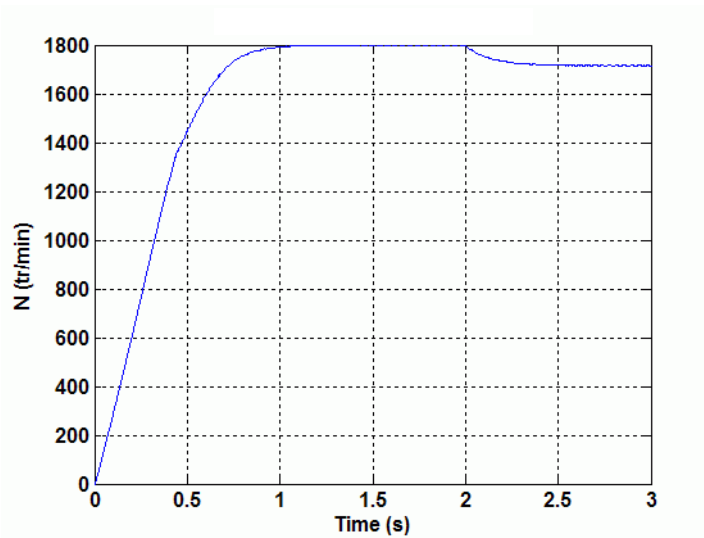

Speed in Capacitor-Start Operation Mode

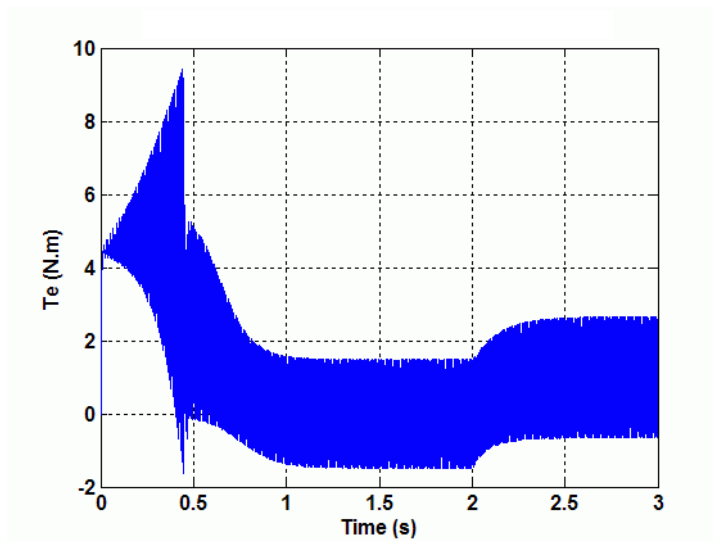

Electromagnetic Torque in Capacitor-Start Operation Mode

Single Phase Asynchronous Machine

Capacitor-Start-Run Operation Mode

An improvement in the operation mode of the single phase asynchronous machine occurs when the auxiliary winding is still connected in series with a capacitor after starting.

The next figures show the simulation wave forms in the capacitor-start-run operation mode single phase asynchronous machine. The magnitude of the torque ripple at steady state is only about 3% of the load torque. It improves the operation of a single phase asynchronous machine by limiting the shaft's vibrations.

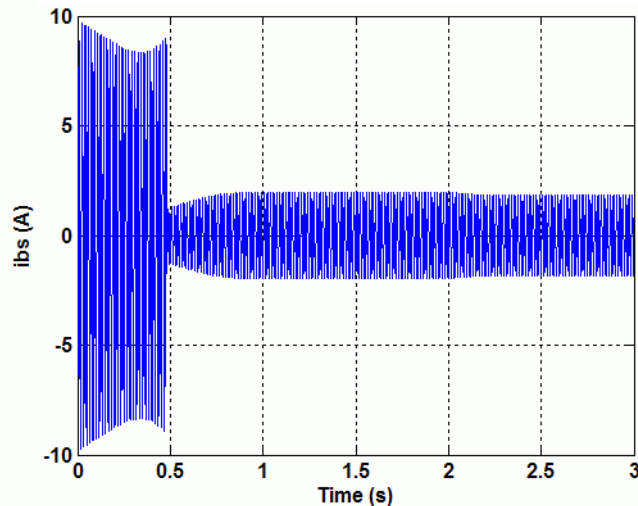

Auxiliary Winding Current in Capacitor-Start-Run Operation Mode

Single Phase Asynchronous Machine

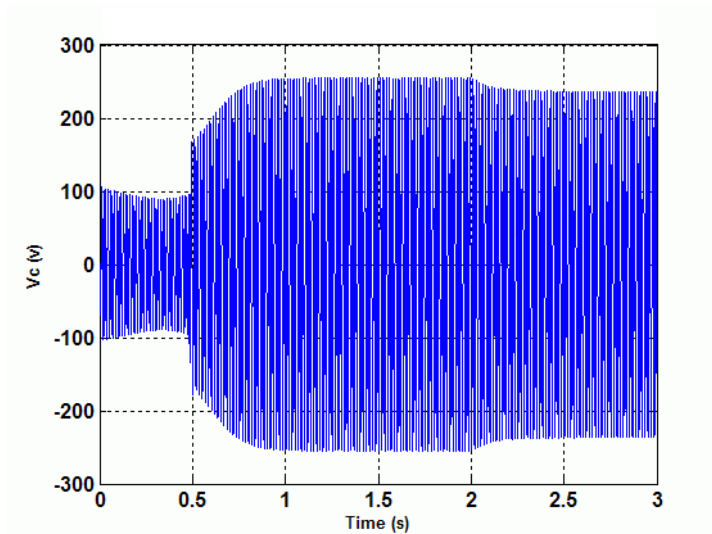

Capacitor Voltage in Capacitor-Start-Run Operation Mode

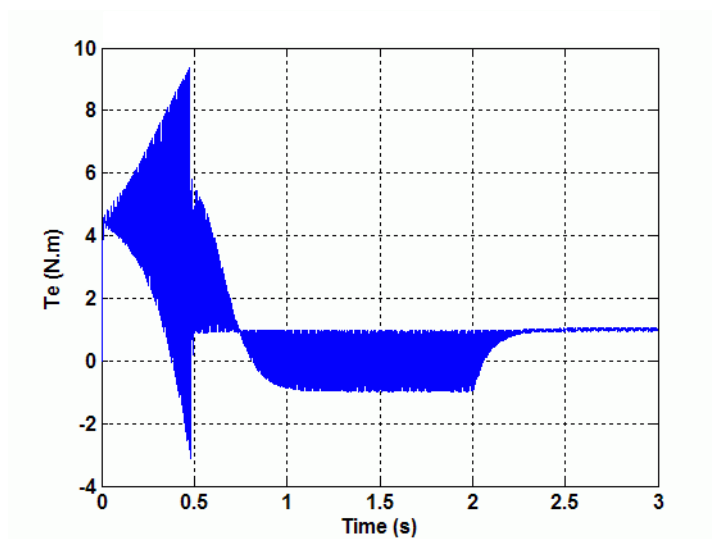

Electromagnetic Torque in Capacitor-Start-Run Operation Mode

Single Phase Asynchronous Machine

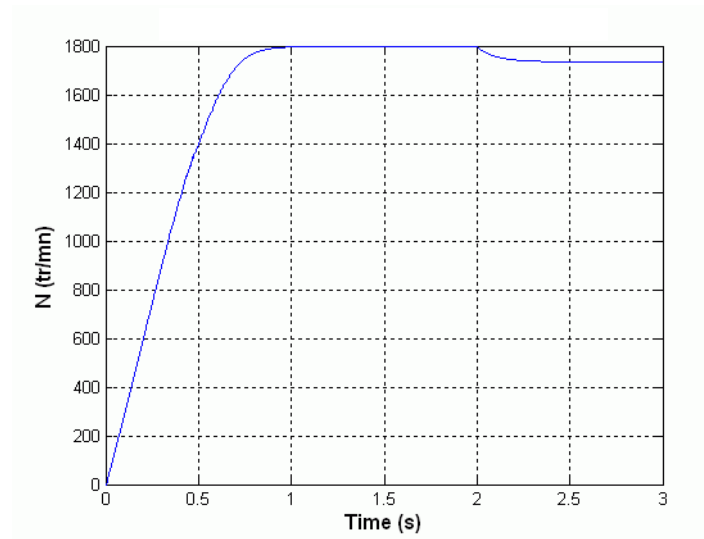

Speed in Capacitor-Start-Run Operation Mode

References

[1] Krause, P.C., O. Wasynczuk, and S.D. Sudhoff, *Analysis of Electric Machinery*, IEEE Press, 1995.

Six-Step VSI Induction Motor Drive

Purpose

Implement a six-step inverter fed Induction Motor Drive

Library

Electric Drives/AC drives

Description

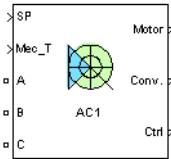

The high-level schematic shown below is built from seven main blocks. The induction motor, the three-phase inverter, the three-phase thyristor rectifier, and the bridge firing unit are provided with the SimPowerSystems library. More details on these four blocks are available in the SimPowerSystems user guide. The three other blocks are specific to the Electric Drives library. These blocks are the DC bus voltage regulator, the six-step generator, and the DC bus voltage filter.

Note In SimPowerSystems, the Six-Step VSI Induction Motor Drive block is commonly called the AC1 motor drive.

High-Level Schematic

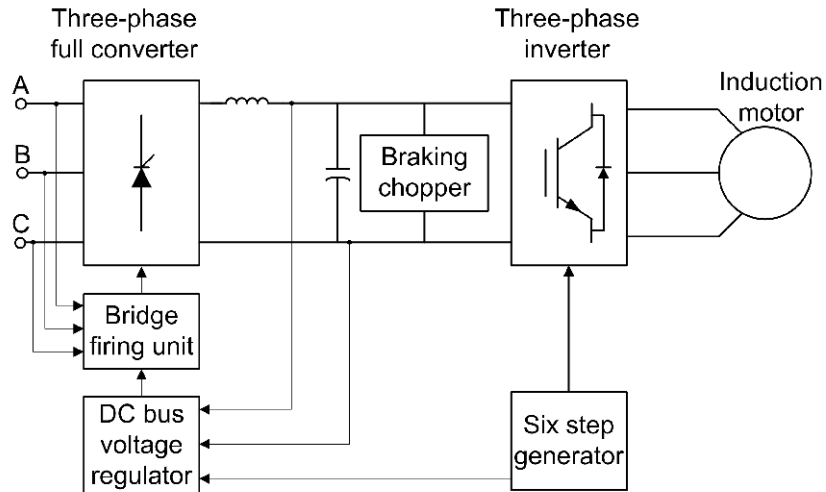

Six-Step VSI Induction Motor Drive

Simulink Schematic

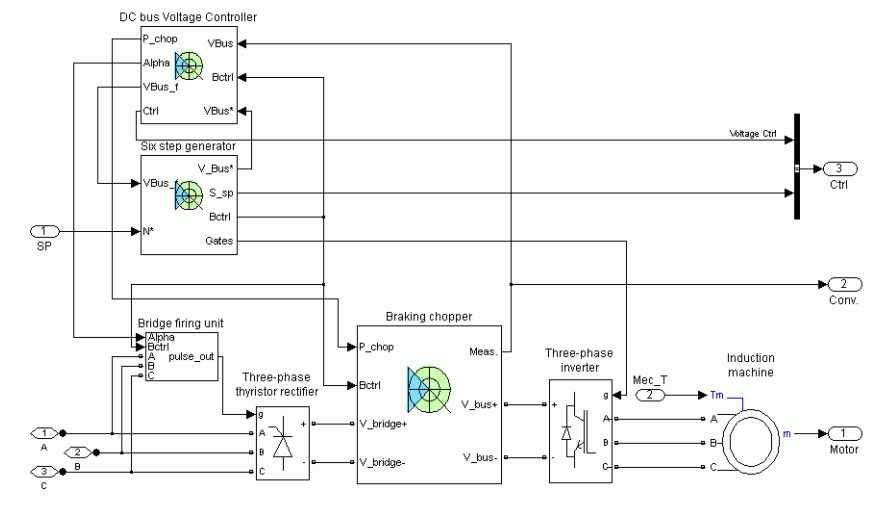

Bridge Firing Unit

The bridge firing unit is used to convert the firing angle, provided by the DC bus voltage regulator, into pulses applied to the thyristor gates. The bridge firing unit block contains notch filters applied to the voltage measurement to remove harmonics. The discrete synchronized six-pulse generator block is used to generate the pulses. Refer to the Synchronized 6-Pulse Generator for more information on this block.

DC Bus Voltage Regulator and Braking Chopper

The DC bus voltage regulator is based on a PI controller and a hysteresis chopper logic. When the bus voltage decreases, the PI controller reduces the firing angle. When the bus voltage increases, the PI controller increases the firing angle. The chopper logic is based on hysteresis control. If the voltage reaches the upper hysteresis limit, the DC voltage controller toggles to braking mode and the chopper is activated, whereas the thyristor bridge is shut off. In chopper mode, the proportional action remains active but the integral gain is set to zero because the chopper dynamics are very high and the integral gain is useless. When the bus voltage reaches the hysteresis lower limit, the braking chopper is shut down and the thyristor bridge is reactivated. The following figure illustrates the DC bus PI regulator.

Six-Step VSI Induction Motor Drive

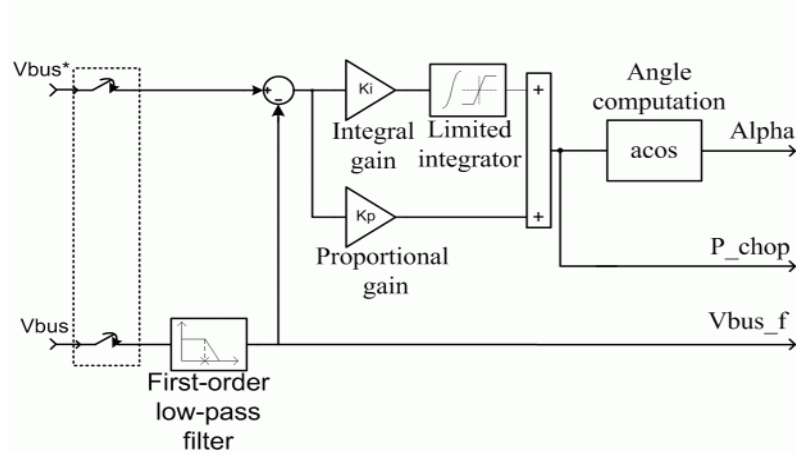

Six-Step Generator

The six-step generator illustrated in the following figure contains six comparators to produce the six-step switching waveforms. Some supplementary logic enables a speed reversal by inverting two phases.

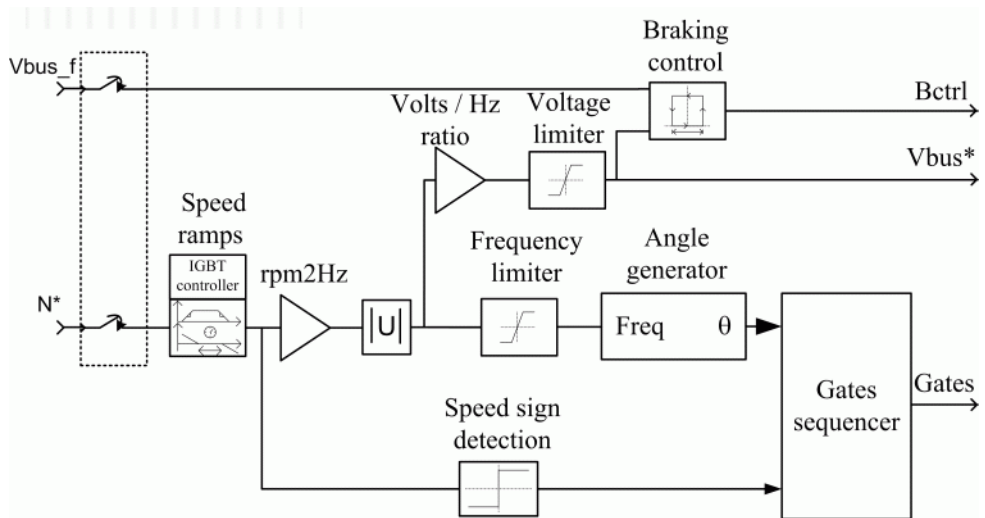

Six-Step VSI Induction Motor Drive

Remarks

In the AC1 motor drive, the motor speed is not regulated in closed loop. Instead, the speed set point is used only to determine the motor voltage and frequency applied by the six-step inverter in order to maintain the (V/F) ratio (or the motor flux) constant from 0 to the nominal speed. Above nominal speed, the motor operates in the flux weakening mode; that is, the voltage is maintained constant at its nominal value while the frequency is increased proportionally to the speed set point.

When reversing speed, a short delay is required at the zero speed crossing so that air gap flux decays to zero.

Six-Step VSI Induction Motor Drive

Dialog Box

Asynchronous Machine Tab

The screenshot shows a software dialog box titled "Six-Step VSI Induction Motor Drive". It has three tabs: "Asynchronous Machine" (selected), "Converters and DC bus", and "Controller". The "Asynchronous Machine" tab is active and contains several sections of parameter input fields:

- Reference frame:** A dropdown menu set to "Stationary".
- Nominal values:** Three input fields: Power (VA) with value 2238, Voltage (Vrms) with value 220, and Frequency (Hz) with value 60.
- Equivalent circuit values:** A table with three columns: Resistance (ohm), Leakage inductance (H), and Mutual inductance (H).

	Resistance (ohm)	Leakage inductance (H)	Mutual inductance (H)
Stator:	0.435	0.002	69.31e-3
Rotor:	0.816	0.002	
- Initial currents:** A table with three columns: Phase A, Phase B, and Phase C. Each column has two rows: Magnitude (A) and Phase (deg).

	Phase A	Phase B	Phase C
Magnitude (A):	0	0	0
Phase (deg):	0	0	0
- Mechanical parameters:** Three input fields: Inertia (kg·m²) with value 0.089, Friction (N·m·s) with value 0.005, and Pole pairs with value 2.
- Initial values:** Two input fields: Slip with value 1, and Angle (deg) with value 0.

At the bottom of the dialog box, there are buttons for "Load", "Save", "OK", "Cancel", "Help", and "Apply".

The asynchronous machine tab displays the parameters of the asynchronous machine block of the powerlib library. Refer to the Asynchronous Machine for more information on the asynchronous machine parameters.

Six-Step VSI Induction Motor Drive

Converters and DC Bus Tab

The screenshot shows the 'Converters and DC bus' tab of the 'Six-Step VSI Induction Motor Drive' software. The window title is 'Six-Step VSI Induction Motor Drive'. Below the title bar, there is a text box explaining that AC motor parameters are in the 'AC Machine' tab, DC bus LC filter, thyristor rectifier, and inverter switches parameters are in this tab, and DC bus regulator and six-step generator parameters are in the 'Controller' tab. The main area is divided into three columns: 'Rectifier', 'Dc Bus', and 'Inverter'. The 'Rectifier' column contains 'Snubbers' (Resistance: 5e3, Capacitance: 100e-9) and 'Thyristors' (On-state resistance: 1e-3, Forward voltage: 1.3). The 'Dc Bus' column contains 'Inductance (H): 1e-3', 'Capacitance (F): 4000e-6', 'Braking chopper' (Resistance: 8), and 'Chopper frequency (Hz): 4000'. The 'Inverter' column contains 'Switches' (Device type: IGBT / Diodes, On-state resistance: 1e-3, Forward voltages: Main device: 1.7, Diode: 1.7, Turn-off characteristics: Fall time: 1e-6, Tail time: 2e-6) and 'Snubbers' (Resistance: 1e3, Capacitance: 20e-9). At the bottom, there are 'Parameters file options' with 'Load' and 'Save' buttons, and a row of 'OK', 'Cancel', 'Help', and 'Apply' buttons.

Rectifier section

The rectifier section of the Converters and DC bus tab displays the parameters of the Universal Bridge block of the powerlib library. Refer to the Universal Bridge for more information on the universal bridge parameters.

Inverter section

The inverter section of the Converters and DC bus tab displays the parameters of the Universal Bridge block of the powerlib library. Refer to the Universal Bridge for more information on the universal bridge parameters.

DC Bus Filter — Inductance

The low-pass DC bus filter inductance (H).

DC Bus Filter — Capacitance

The low-pass DC bus filter capacitance (F).

Braking Chopper section**Resistance**

The braking chopper resistance used to avoid bus over-voltage during motor deceleration or when the load torque tends to accelerate the motor (Ω).

Frequency

The braking chopper frequency (Hz).

Six-Step VSI Induction Motor Drive

Controller Tab

Six-Step VSI Induction Motor Drive

The AC motor parameters are specified in the AC Machine tab. The DC bus LC filter, the thyristor rectifier and the inverter switches parameters are specified in the Converter and DC bus tab. DC bus regulator and six step generator parameters are specified in the Controller Tab.

Asynchronous Machine Converters and DC bus **Controller** Schematic

DC bus control

Voltage sensor cutoff frequency (Hz): 30

Network frequency (Hz): 60

DC bus negative deviation (V): 20

DC bus positive deviation (V): 20

PI regulator

Proportional gain: 0.01 Integral gain: 0.1

Bus voltage limits (V)

Minimum: 30 Maximum: 280

Six step generator

Speed ramps (rpm/s)

Acceleration: 2000 Deceleration: -2000

Output frequency limits (Hz)

Minimum: 0 Maximum: 120

Volts / Hertz ratio: 5 Zero speed crossing time (s): 0.5

Parameters file options

Load Save

OK Cancel Help Apply

Schematic Button

When you press this button, a diagram illustrating the speed and current controllers schematics appears.

DC Bus Control section

Voltage Sensor Cutoff Frequency

The DC bus voltage measurement first-order filter cutoff frequency (Hz).

DC Bus Negative Deviation

The maximum deviation of the actual bus voltage under the DC bus set point. Refer to the figure shown in the DC Bus Positive Deviation parameter section.

Six-Step VSI Induction Motor Drive

DC Bus Positive Deviation

The maximum deviation of the actual bus voltage over the DC bus set point.

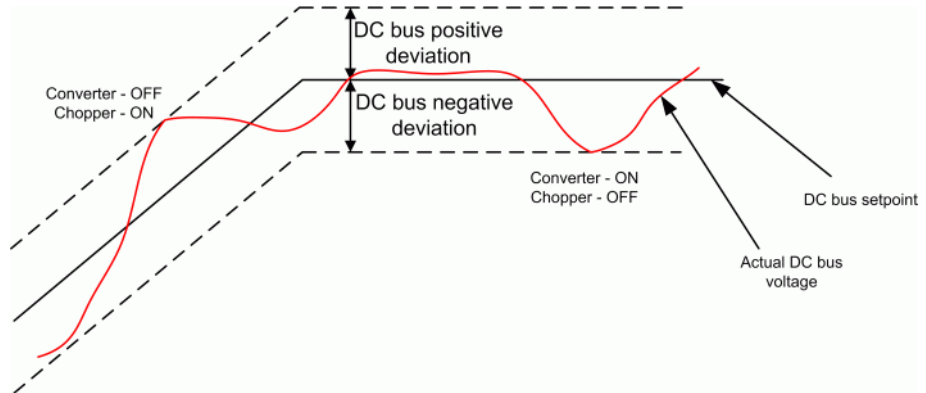

Proportional Gain

The proportional gain of the DC bus PI controller.

Integral Gain

The integral gain of the DC bus PI controller.

Voltage limits — Minimum

The minimum DC bus voltage (V).

Voltage limits — Maximum

The maximum DC bus voltage (V).

Six-Step Generator section

Volts / Hertz Ratio

The proportionality constant between the stator line-to-line RMS voltage and frequency (V / Hz).

Zero Speed Crossing Time

The delay at zero speed to eliminate the motor air gap residual flux (s).

Six-Step VSI Induction Motor Drive

Speed Ramps — Acceleration

The maximum change of speed allowed during motor acceleration. An excessively large positive value can cause DC bus under-voltage and undesirable harmonics on the line side voltages (rpm/s).

Speed Ramps — Deceleration

The maximum change of speed allowed during motor deceleration. An excessively large negative value can cause DC bus over-voltage (rpm/s).

Frequency Limits — Minimum

The six-step generator minimum output frequency (Hz).

Frequency Limits — Maximum

The six-step generator maximum output frequency (Hz).

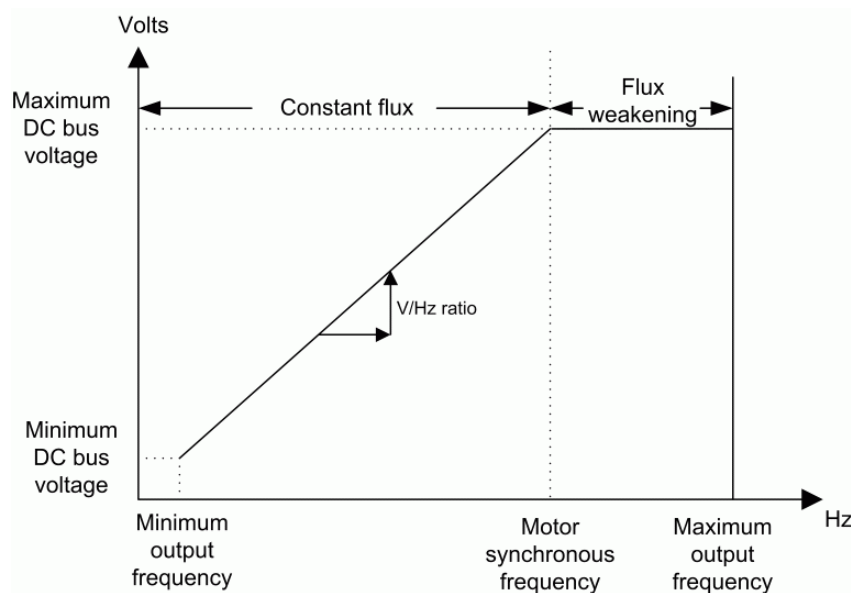

Graphical Representation of the Six-Step Generator Limits

Block Inputs and Outputs

SP

The speed or torque set point. Note that the speed set point can be a step function, but the speed change rate will follow the acceleration /

Six-Step VSI Induction Motor Drive

deceleration ramps. If the load torque and the speed have opposite signs, the accelerating torque will be the sum of the electromagnetic and load torques.

Mec_T

The mechanical load torque input.

A, B, C

The three phase terminals of the motor drive.

Motor

The motor measurement vector. This vector allows you to observe the motor's variables using the Bus Selector block.

Conv

The three-phase converters measurement vector. This vector contains:

- The rectifier output voltage
- The inverter output voltage
- The rectifier input current
- The inverter output current

Note that all current and voltage values of the bridges can be visualized with the Multimeter block.

Ctrl

The controller measurement vector. This vector contains:

- The firing angle computed by the current controller
- The speed error (difference between the speed reference ramp and actual speed)
- The speed reference ramp

Six-Step VSI Induction Motor Drive

Model Specifications

The library contains a 3 hp and a 500 hp drive parameter set. The specifications of these two drives are shown in the following table.

3 HP and 500 HP Drive Specifications

		3 HP Drive	500 HP Drive
Drive Input Voltage			
	Amplitude	220 V	2300 V
	Frequency	60 Hz	60 Hz
Motor Nominal Values			
	Power	3 hp	500 hp
	Speed	1705 rpm	1773 rpm
	Voltage	220 V	2300 V

Example

The ac1_example demo illustrates a typical operation of the AC1 motor drive. A speed reference step from zero to 1800 rpm is applied at $t = 0$.

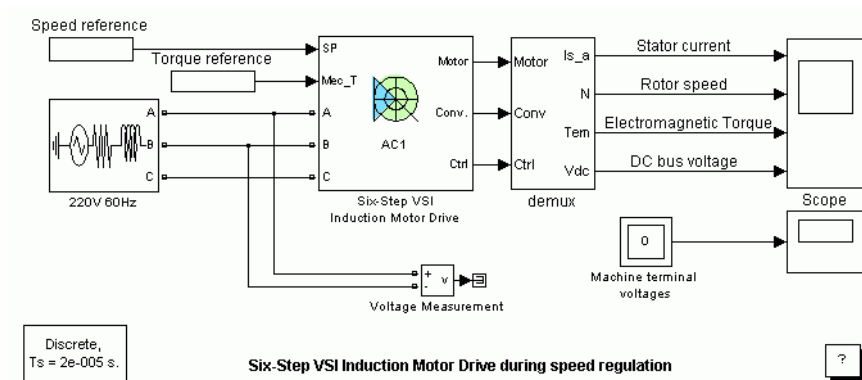

As shown in the following figure, the speed set point doesn't go instantaneously to 1800 rpm but follows the acceleration ramp (2000 rpm/s). The motor reaches steady state at $t = 1.3$ s. At $t = 2$ s, an accelerating torque is applied on the motor's shaft. You can observe a speed increase. Because the rotor speed is higher than the synchronous speed, the motor is working in the generator

Six-Step VSI Induction Motor Drive

mode. The braking energy is transferred to the DC link and the bus voltage tends to increase. However, the over-voltage activates the braking chopper, which causes the voltage to decrease. In this example, the braking resistance is not big enough to avoid a voltage increase but the bus is maintained within tolerable limits. At $t = 3$ s, the torque applied to the motor's shaft steps from -11 N.m to $+11$ N.m. You can observe a DC voltage and speed drop at this point. The DC bus controller switches from braking to motoring mode. At $t = 4$ s, the load torque is removed completely.

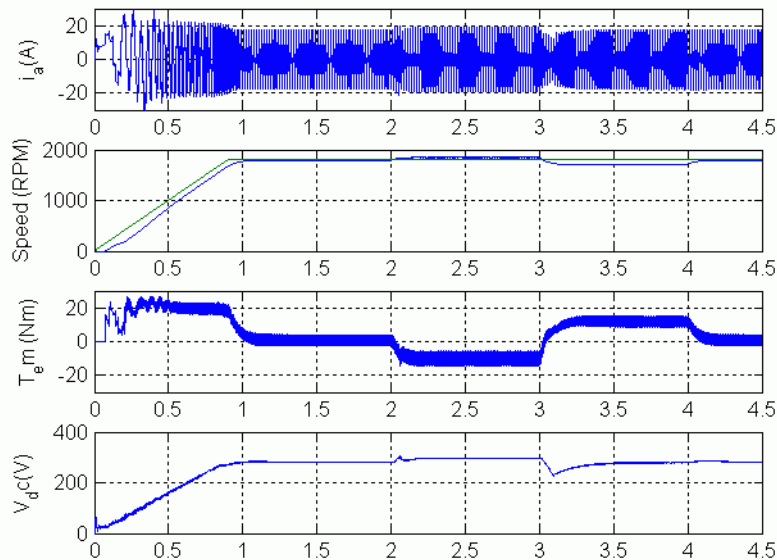

References

- [1] Bose, B. K., *Modern Power Electronics and AC Drives*, Prentice-Hall, N.J., 2002.
- [2] Harunur, M. R., *Power Electronics*, Prentice-Hall, 1988.

Space Vector PWM VSI Induction Motor Drive

Purpose

Implement a space vector PWM VSI induction motor drive

Library

Electric Drives/AC drives

Description

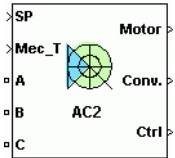

The high-level schematic shown below is built from six main blocks. The induction motor, the three-phase inverter, and the three-phase diode rectifier models are provided with the SimPowerSystems library. More details on these three blocks are available in the SimPowerSystems user guide. The speed controller, the braking chopper, and the space vector modulator models are specific to the drive library. It is possible to use a simplified version of the drive containing an average-value model of the inverter for faster simulation.

Note In SimPowerSystems, the Space Vector PWM VSI Induction Motor Drive block is commonly called the AC2 motor drive.

High-Level Schematic

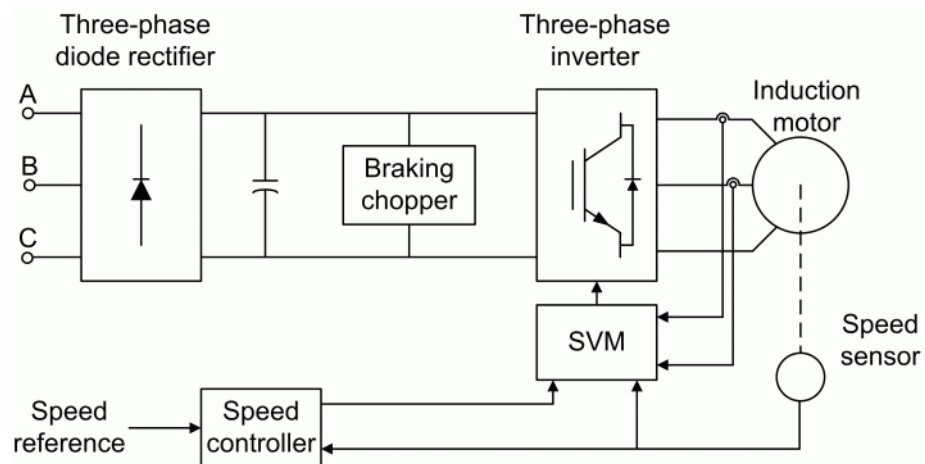

Simulink Schematic

Space Vector PWM VSI Induction Motor Drive

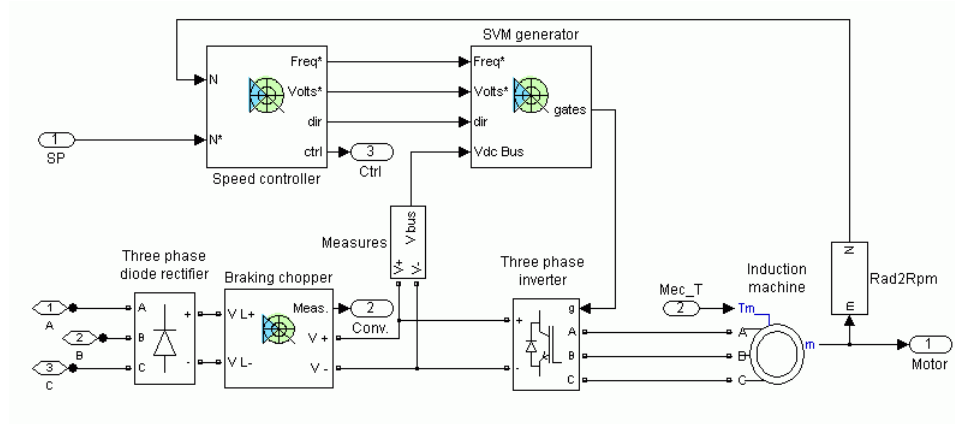

Speed Controller

The speed controller is based on a PI regulator that controls the motor slip. As shown in the following figure, the slip value computed by the PI regulator is added to the motor speed in order to produce the demanded inverter frequency. The latter frequency is also used to generate the demanded inverter voltage in order to maintain the motor V/F ratio constant.

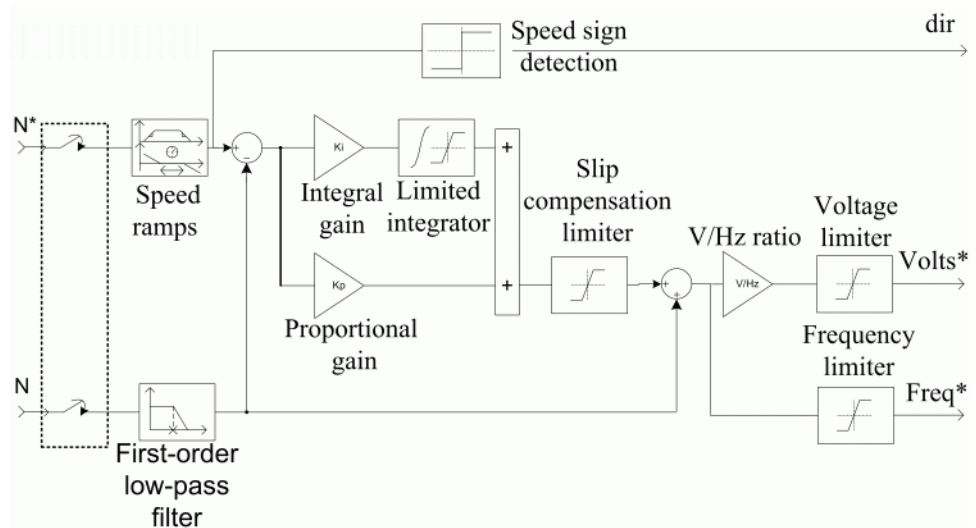

Space Vector PWM VSI Induction Motor Drive

Space Vector Modulator

The space vector modulator (SVM) contains seven blocks, shown in the following figure. These blocks are described below.

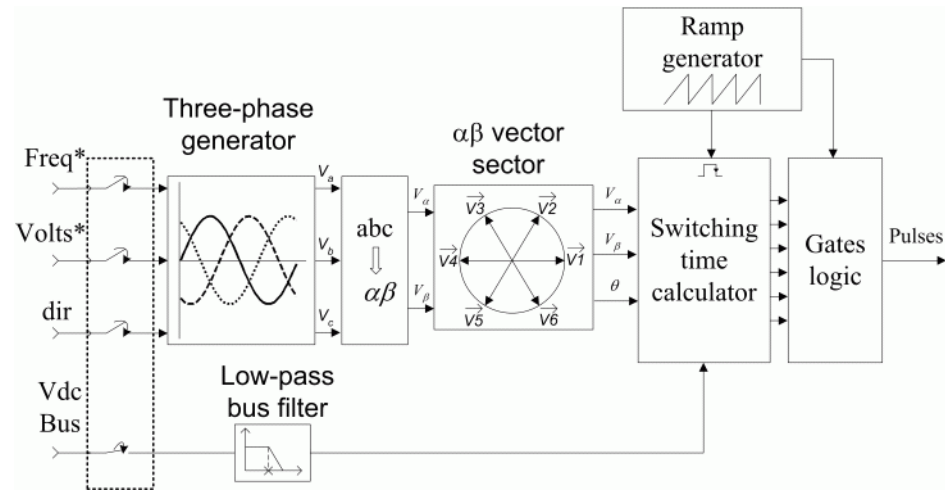

The *three-phase generator* is used to produce three sine waves with variable frequency and amplitude. The three signals are out of phase with each other by 120 degrees. The inverter demanded frequency and voltage are two of the block inputs.

The *low-pass bus filter* is used to remove fast transients from the DC bus voltage measurement. This measure is used to compute the voltage vector applied to the motor.

The *alpha beta transformation* converts variables from the three-phase system to the two-phase $\alpha\beta$ system.

The *$\alpha\beta$ vector sector* is used to find the sector of the $\alpha\beta$ plane in which the voltage vector lies. The $\alpha\beta$ plane is divided into six different sectors spaced by 60 degrees.

The *ramp generator* is used to produce a unitary ramp at the PWM switching frequency. This ramp is used as a time base for the switching sequence.

The *switching time calculator* is used to calculate the timing of the voltage vector applied to the motor. The block input is the sector in which the voltage vector lies.

Space Vector PWM VSI Induction Motor Drive

The *gates logic* receives the timing sequence from the *switching time calculator* and the ramp from the *ramp generator*. This block compares the ramp and the gate timing signals to activate the inverter switches at the proper time.

When using the average-value inverter, the *gates logic* block is disabled and the inverter leg PWM duty cycles are issued by the *switching time calculator* to control the average-value inverter.

Average-Value Inverter

The average-value inverter is shown in the following figure.

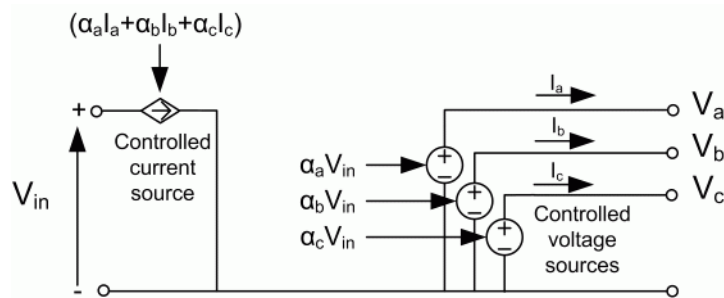

It is composed of one controlled current source on the DC side and three controlled voltage sources on the AC side. The DC current source allows the representation of the average DC bus current behavior, following the next equation:

$$I_{dc} = \alpha_a I_a + \alpha_b I_b + \alpha_c I_c$$

with α_a , α_b , α_c being the PWM duty cycles of the inverter legs A, B, and C respectively, and I_a , I_b , I_c the corresponding three-phase currents. The three AC voltage sources represent the average voltage values of the three-phase inverter voltages V_a , V_b , V_c , following the next equation:

$$V_a = \alpha_a V_{in}$$

$$V_b = \alpha_b V_{in}$$

$$V_c = \alpha_c V_{in}$$

with V_{in} being the input DC bus voltage value.

Space Vector PWM VSI Induction Motor Drive

Braking Chopper

The braking chopper block contains the DC bus capacitor and the dynamic braking chopper, which is used to absorb the energy produced by a motor deceleration.

Remarks

The model is discrete. Good simulation results have been obtained with a 2 μ s time step. In order to simulate a digital controller device, the control system has two different sampling times:

- The speed controller sampling time
- The SVM controller sampling time

The speed controller sampling time has to be a multiple of the SVM sampling time. The latter sampling time has to be a multiple of the simulation time step.

The simulation step size must be chosen in accordance with the inverter's switching frequency. A rule of thumb is to choose a simulation step size 100 times smaller than the switching period. If the simulation step size is set too high, the simulation results can be erroneous. The average-value inverter allows the use of bigger simulation time steps since it does not generate small time constants (due to the RC snubbers) inherent to the detailed converter. For a controller sampling time of 20 μ s, good simulation results have been obtained for a simulation time step of 20 μ s. This time step can, of course, not be higher than the controller time step.

In the AC2 motor drive, the motor speed is regulated by controlling the motor slip. The motor current or torque is not regulated, however, so the speed response tends to be sluggish at low speed because of torque ripple.

When reversing speed, a short delay is required at the zero speed crossing so that air gap flux decays to zero.

Space Vector PWM VSI Induction Motor Drive

Dialog Box

Asynchronous Machine Tab

The dialog box is titled "Space Vector PWM VSI Induction Motor Drive" and contains the following sections:

- Reference frame:** Stationary (dropdown menu)
- Nominal values:**
 - Power (VA): 2238
 - Voltage (Vrms): 220
 - Frequency (Hz): 60
- Equivalent circuit values:**
 - Resistance (ohm):
 - Stator: 0.435
 - Rotor: 0.816
 - Leakage inductance (H):
 - Stator: 0.002
 - Rotor: 0.002
 - Mutual inductance (H): 69.31e-3
- Initial currents:**

	Phase A:	Phase B:	Phase C:
Magnitude (A):	0	0	0
Phase (deg):	0	0	0
- Mechanical parameters:**
 - Rotor values:
 - Inertia (kg*m²): 0.089
 - Friction (N-m-s): 0.005
 - Pole pairs: 2
 - Initial values:
 - Slip: 1
 - Angle (deg): 0
- Model detail level:** Detailed (dropdown menu)
- Parameters file options:** Load, Save buttons
- Buttons:** OK, Cancel, Help, Apply

The asynchronous machine tab displays the parameters of the asynchronous machine block of the powerlib library. Refer to Asynchronous Machine for more information on the asynchronous machine parameters.

Space Vector PWM VSI Induction Motor Drive

Converters and DC Bus Tab

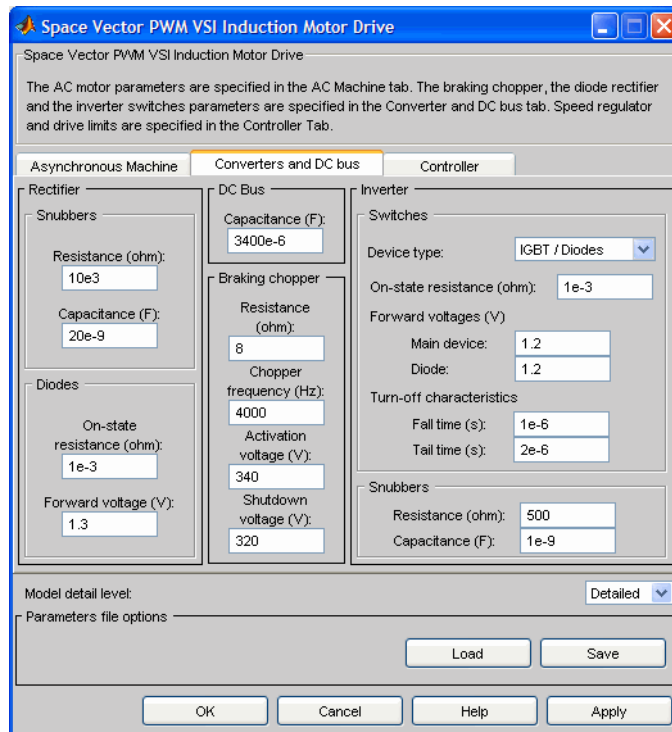

Rectifier section

The rectifier section of the Converters and DC bus tab displays the parameters of the Universal Bridge block of the powerlib library. Refer to the Universal Bridge for more information on the universal bridge parameters.

Inverter section

The inverter section of the Converters and DC bus tab displays the parameters of the Universal Bridge block of the powerlib library. Refer to the Universal Bridge for more information on the universal bridge parameters. This parameter is not used when using the average-value inverter.

Space Vector PWM VSI Induction Motor Drive

Braking Chopper section

Capacitance

The DC bus capacitance (F).

Resistance

The braking chopper resistance used to avoid bus over-voltage during motor deceleration or when the load torque tends to accelerate the motor (Ω).

Frequency

The braking chopper frequency (Hz).

Activation and Shutdown Voltage

The dynamic braking is activated when the bus voltage reaches the upper limit of the hysteresis band. The dynamic braking is shut down when the bus voltage reaches the lower limit of the hysteresis band. The following figure illustrates the braking hysteresis logic.

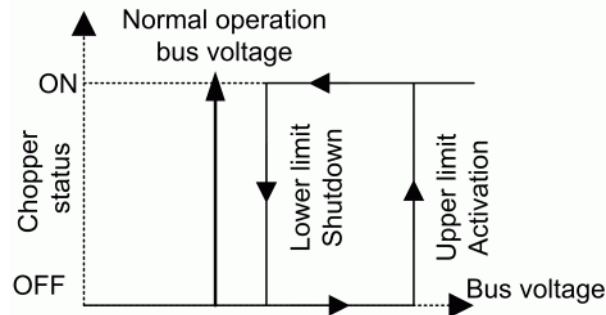

Space Vector PWM VSI Induction Motor Drive

Controller Tab

Space Vector PWM VSI Induction Motor Drive

The AC motor parameters are specified in the AC Machine tab. The braking chopper, the diode rectifier and the inverter switches parameters are specified in the Converter and DC bus tab. Speed regulator and drive limits are specified in the Controller Tab.

Asynchronous Machine Converters and DC bus **Controller**

Schematic

Speed controller

Speed ramps (rpm/s)

Acceleration: 1800 Deceleration: -1800

PI regulator

Proportional gain: 9 Integral gain: 10

Output limits

Controller: Minimum: -30 Maximum: 30

Frequency (Hz): 0.05 120

Voltage (V): 10 180

Sampling time (s): 100e-6 Sensor cutoff frequency (Hz): 100 Voltz / Hertz ratio: 3.2 Zero speed crossing time (s): 0.4

SVM generator

SVM switching frequency (Hz): 4500 DC bus voltage sensor cutoff frequency (Hz): 50 Sampling time (s): 20e-6

Model detail level: Detailed

Parameters file options

Load Save

OK Cancel Help Apply

Schematic Button

When you press this button, a diagram illustrating the speed and current controllers schematics appears.

Speed Controller section

Speed Ramps — Acceleration

The maximum change of speed allowed during motor acceleration. An excessively large positive value can cause DC bus under-voltage (rpm/s).

Speed Ramps — Deceleration

The maximum change of speed allowed during motor deceleration. An excessively large negative value can cause DC bus over-voltage (rpm/s).

Space Vector PWM VSI Induction Motor Drive

Proportional Gain

The speed controller proportional gain.

Integral Gain

The speed controller integral gain.

Output Negative Saturation

The maximum negative slip compensation computed by the slip regulator (Hz).

Output Positive Saturation

The maximum positive slip compensation computed by the slip regulator (Hz).

Minimum Frequency

The minimum demanded inverter frequency applied to the motor (Hz).

Maximum Frequency

The maximum demanded inverter frequency applied to the motor (Hz).

Minimum Output Voltage

The minimum demanded inverter output voltage (V). If this parameter is set to zero, the zero speed cannot be reached under several load conditions.

Maximum Output Voltage

The maximum demanded inverter output voltage (V). This parameter must be set in accordance with the motor rating. If this parameter is set too high, you will observe over-modulation in the current and voltage waveforms.

Volts / Hertz Ratio

The proportionality constant between the stator line-to-line RMS voltage and frequency (V / Hz).

Zero Speed Crossing Time

The delay at zero speed to eliminate the motor air gap residual flux (s).

Speed Sensor Cutoff Frequency

The speed measurement first-order low-pass filter cutoff frequency (Hz).

Sampling Time

The speed controller sampling time (s). The sampling time must be a multiple of the simulation time step.

Space Vector PWM VSI Induction Motor Drive

SVM Generator section

Switching Frequency

The inverter switching frequency (Hz).

Voltage Sensor Cutoff Frequency

The cutoff frequency of the first-order low-pass filter applied to the DC bus voltage measurement.(Hz).

Sampling Time

The SVM generator sampling time (s). The sampling time must be a multiple of the simulation time step.

Block Inputs and Outputs

SP

The speed or torque set point. Note that the speed set point can be a step function, but the speed change rate will follow the acceleration / deceleration ramps. If the load torque and the speed have opposite signs, the accelerating torque will be the sum of the electromagnetic and load torques.

Mec_T

The mechanical load torque input.

A, B, C

The three phase terminals of the motor drive.

Motor

The motor measurement vector. This vector allows you to observe the motor's variables using the Bus Selector block.

Conv

The three-phase converters measurement vector. This vector contains:

- The DC bus voltage
- The rectifier output current
- The inverter input current

Note that all current and voltage values of the bridges can be visualized with the Multimeter block.

Ctrl

The controller measurement vector. This vector contains:

Space Vector PWM VSI Induction Motor Drive

- The slip compensation
- The speed error (difference between the speed reference ramp and actual speed)
- The speed reference ramp

Model Specifications

The library contains a 3 hp and a 200 hp drive parameter set. The specifications of these two drives are shown in the following table.

3 HP and 200 HP Drive Specifications

		3 HP Drive	200 HP Drive
Drive Input Voltage			
	Amplitude	220 V	575 V
	Frequency	60 Hz	60 Hz
Motor Nominal Values			
	Power	3 hp	200 hp
	Speed	1705 rpm	1785 rpm
	Voltage	220 V	575 V

Example

The ac2_example demo illustrates an AC2 induction motor drive simulation with standard load conditions. At time $t = 0$ s, the speed set point is 1000 rpm.

Space Vector PWM VSI Induction Motor Drive

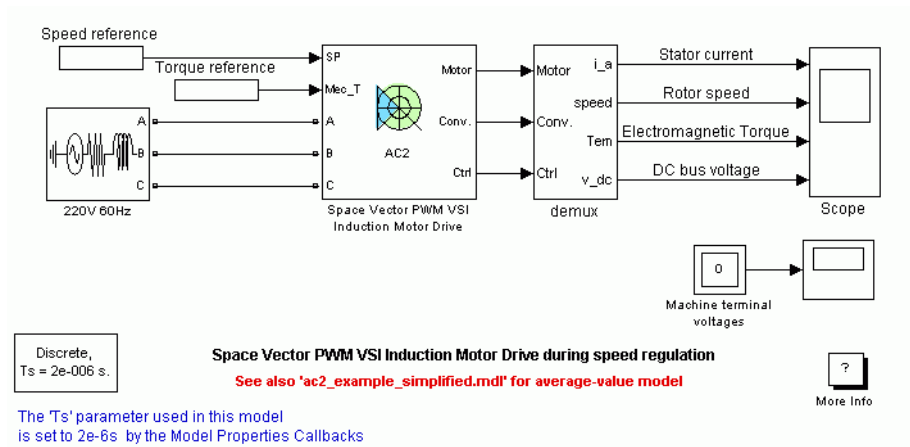

As shown in the following figure, the speed precisely follows the acceleration ramp. At $t = 0.5$ s, the nominal load torque is applied to the motor. At $t = 1$ s, the speed set point is changed to 1500 rpm. The speed increases to 1500 rpm. At $t = 1.5$ s, the mechanical load passes from 11 N.m to -11 N.m. The figure illustrates the results obtained respectively with the detailed and the average-value inverter. Average voltage, current, torque, and speed values are identical for both models. The higher frequency signal components are not represented with the average-value converter.

Space Vector PWM VSI Induction Motor Drive

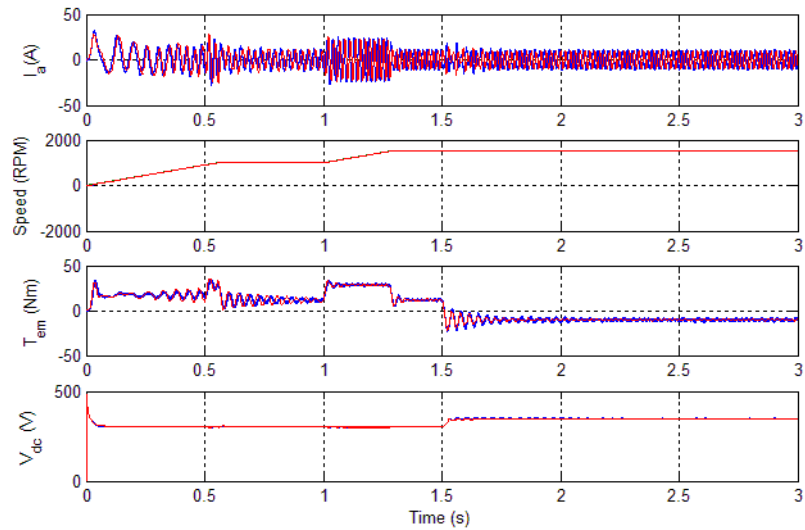

AC2 Example Waveforms (Blue : Detailed Converter, Red : Average-Value Converter)

References

- [1] Bose, B. K., *Modern Power Electronics and AC Drives*, Prentice-Hall, N.J., 2002.
- [2] Grelet, G., and G. Clerc, *Actionneurs électriques*, Éditions Eyrolles, Paris, 1997.
- [3] Krause, P. C., *Analysis of Electric Machinery*, McGraw-Hill, 1986.

Speed Reducer

Purpose

Implement a speed reducer

Library

Electric Drives/Shafts and Speed Reducers

Description

The high-level schematic shown below is built from three main blocks: a high-speed shaft, a reduction device, and a low-speed shaft. More details on the shaft model are included in the Mechanical Shaft reference pages.

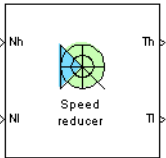

High-Level Schematic

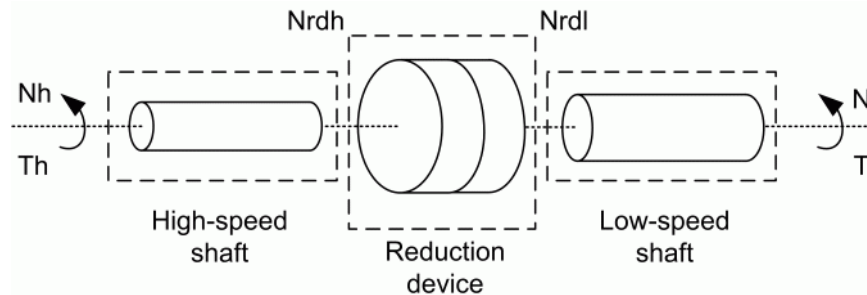

Simulink Schematic

The next figure shows the Simulink schematic of the speed reducer model.

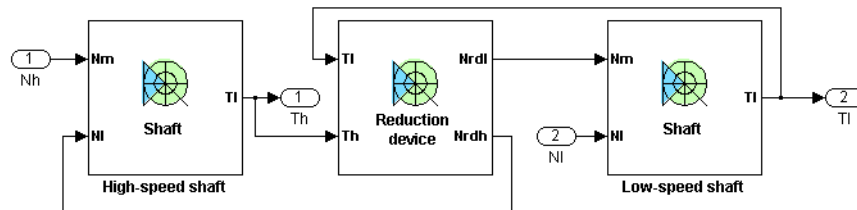

Reduction Device

The reduction device dynamics are governed by the following equation:

$$J_{rdh} \cdot \ddot{\theta}_{rdh} = T_h - \frac{T_l}{(\eta \cdot i)}$$

where J_{rdh} is the inertia of the reduction device with respect to the high-speed side, $\ddot{\theta}_{rdh}$ is the acceleration of the high-speed side of the reduction device, T_h is the torque transmitted by the high-speed shaft to the input of the reduction device, T_l is the torque transmitted by the low-speed shaft from the output of the reduction device, η is the efficiency of the reduction device, and i is the reduction ratio ($i \geq 1$).

For reduction devices composed of gears, the efficiency varies according to the type of gears, the number of stages (thus the reduction ratio), the lubricant, etc. For small reduction ratios, the efficiency can climb up to 95%. For higher reduction ratios, the efficiency can be as low as 75%. However, most commercial speed reducers now have high efficiencies of 90% to 95%.

The output speed N_{rdl} (the speed of the driving side of the low-speed shaft) of the reduction device is given by the following equation:

$$N_{rdl} = \frac{N_{rdh}}{i}$$

where N_{rdh} is the input speed of the reduction device (the speed of the loaded side of the high-speed shaft).

The following figure shows the reduction device schematic.

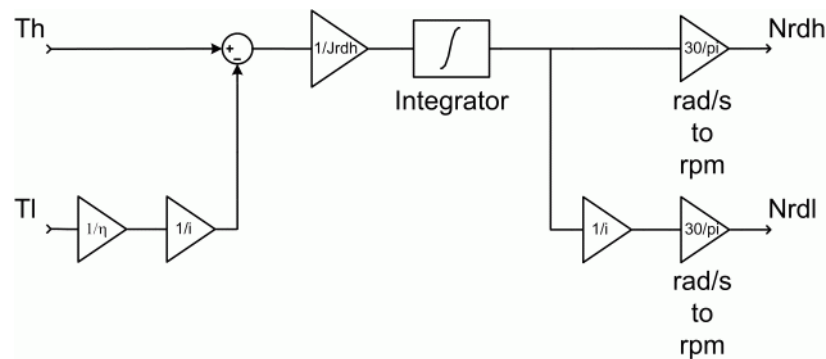

Remarks

The stiffness of the shafts must be high enough to avoid large angular deflections that could cause misalignment inside the bearings and damage.

Keep in mind that the low-speed shaft will have a higher stiffness and a higher damping factor than the high-speed shaft, the torque on the low-speed shaft

Speed Reducer

being a lot bigger. For proper simulation results, the damping factor of both shafts must be high enough to avoid undesired transient speed and torque oscillations.

Too high stiffness and damping factor values or too low gearbox inertias can cause simulation errors.

The model is discrete. Good simulation results have been obtained with a $1 \mu\text{s}$ time step.

Dialog Box

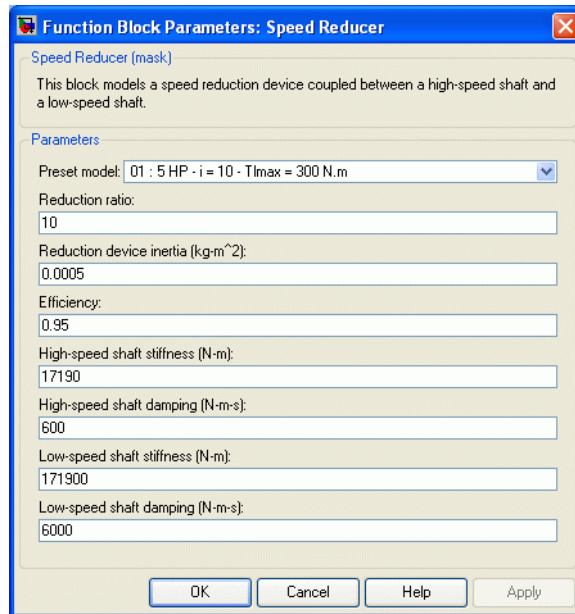

Preset Model

This pop-up menu allows you to choose preset model parameters.

Reduction Ratio

The reduction ratio of the speed reducer ($i \geq 1$).

Reduction Device Inertia

The inertia of the reduction device with respect to the high-speed side (kg.m²).

Efficiency

The efficiency of the reduction device.

High-Speed Shaft Stiffness

The stiffness of the high-speed shaft (N.m).

Speed Reducer

High-Speed Shaft Damping

The internal damping of the high-speed shaft (N.m.s).

Low-Speed Shaft Stiffness

The stiffness of the low-speed shaft (N.m).

Low-Speed Shaft Damping

The internal damping of the low-speed shaft (N.m.s).

Block Inputs and Outputs

Inputs

The block has two inputs: N_h and N_l .

The first input, N_h , is the speed (rpm) of the driving end of the high-speed shaft.

The second input, N_l , is the speed (rpm) of the loaded end of the low-speed shaft.

Outputs

The block has two outputs: T_h and T_l .

The T_h output is the torque transmitted by the high-speed shaft to the reduction device.

The T_l output is the torque transmitted by the low-speed shaft to the load.

Model Specifications

The library contains four preset models. The specifications of these speed reducer models are shown in the following table.

Preset Speed Reducer Models

	1st	2nd	3rd	4th
Power (hp)	5	5	200	200
Reduction ratio	10	100	10	100
Max. output torque (N.m)	300	3000	12200	122000

The high-speed and low-speed shafts of the preset models have been designed in order to present 0.1 degrees of angular deflection at maximum torque.

Example

The reducer_example demo illustrates the speed reducer model.

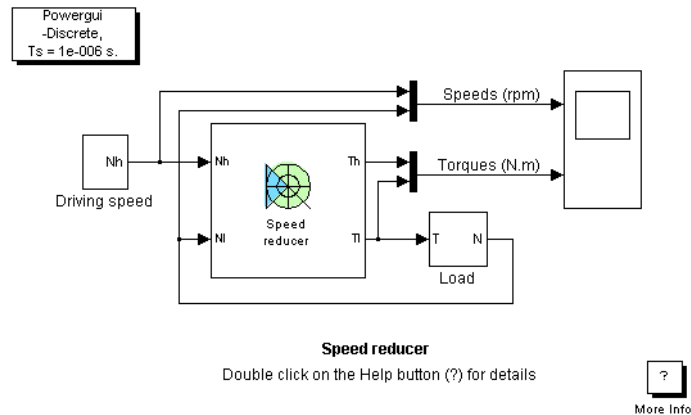

The speed reducer is driven by a variable-speed source and is connected to a load. The load has an inertia of 30 kg.m² and a viscous friction term of 0.5 N.m.s.

The speed reducer has a reduction ratio of 10, and the inertia of the reduction device with respect to the high-speed side is 0.0005 kg.m². The reduction ratio being quite low, the efficiency is high and worth 0.95.

The high-speed shaft has a stiffness of 17190 N.m and an internal damping factor of 600 N.m.s. This shaft is designed to have 0.1 degree of angular deflection for a 30 N.m load torque. The low-speed shaft, having a higher torque to transmit, has a stiffness of 171900 N.m and an internal damping factor of 6000 N.m.s. This shaft is designed to have 0.1 degree of angular deflection for a 300 N.m load torque.

At $t = 0$ s, the driving speed starts climbing to 1750 rpm with a 500 rpm/s acceleration ramp. This causes the transmitted torque of the high-speed shaft to jump to about 18 N.m. Because of the reduction device, the torque transmitted to the load by the low-speed shaft is a lot bigger and is worth about 170 N.m.

During the accelerating phase, both torques keep increasing in order to compensate the viscous friction of the load. Notice that the load accelerates with a ramp of +50 rpm/s because of the reduction ratio of the gearbox.

Speed Reducer

At $t = 3.5$ s, the driving speed settles at 1750 rpm. Since no more accelerating torque is needed, the input and output torques decrease and stabilize respectively to 0.965 N.m and 9.16 N.m at $t = 4$ s. The load speed is now equal to 175 rpm.

The following figure shows the speed reducer input and output speeds and torques.

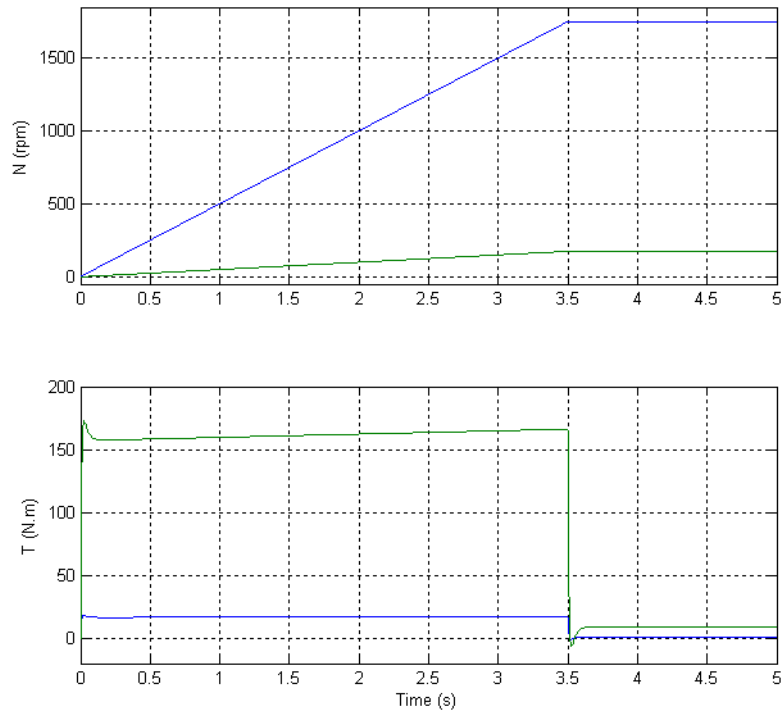

References

- [4] Norton, Robert L., *Machine Design*, Prentice Hall, 1998.
- [5] Nise, Norman S., *Control Systems Engineering*, Addison-Wesley Publishing Company, 1995.

Static Synchronous Compensator (Phasor Type)

Purpose

Implements a phasor model of a three-phase static synchronous compensator

Library

Flexible AC Transmission Systems (FACTS)/Power-Electronics Based FACTS

Description

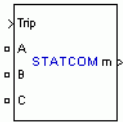

The Static Synchronous Compensator (STATCOM) is a shunt device of the Flexible AC Transmission Systems (FACTS) family using power electronics to control power flow and improve transient stability on power grids [1]. The STATCOM regulates voltage at its terminal by controlling the amount of reactive power injected into or absorbed from the power system. When system voltage is low, the STATCOM generates reactive power (STATCOM capacitive). When system voltage is high, it absorbs reactive power (STATCOM inductive).

The variation of reactive power is performed by means of a Voltage-Sourced Converter (VSC) connected on the secondary side of a coupling transformer. The VSC uses forced-commutated power electronic devices (GTOs, IGBTs or IGCTs) to synthesize a voltage V_2 from a DC voltage source. The principle of operation of the STATCOM is explained on the figure below showing the active and reactive power transfer between a source V_1 and a source V_2 . In this figure, V_1 represents the system voltage to be controlled and V_2 is the voltage generated by the VSC.

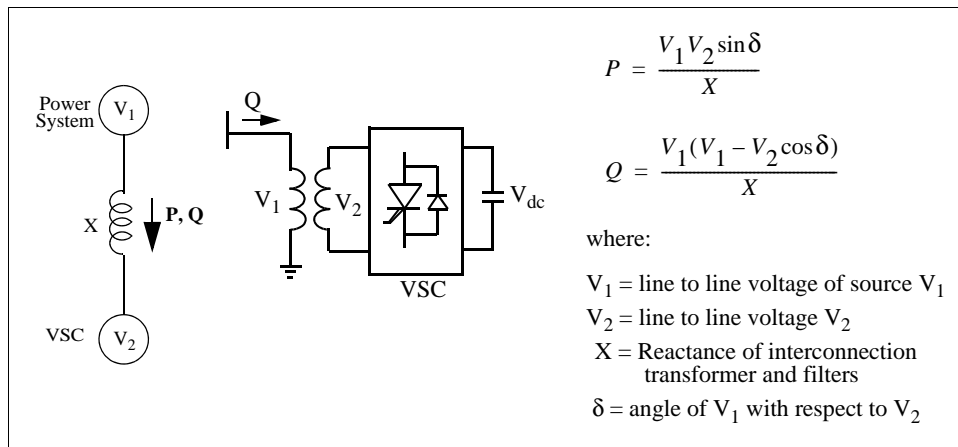

Operating Principle of the STATCOM

Static Synchronous Compensator (Phasor Type)

In steady state operation, the voltage V_2 generated by the VSC is in phase with V_1 ($\delta=0$), so that only reactive power is flowing ($P=0$). If V_2 is lower than V_1 , Q is flowing from V_1 to V_2 (STATCOM is absorbing reactive power). On the reverse, if V_2 is higher than V_1 , Q is flowing from V_2 to V_1 (STATCOM is generating reactive power). The amount of reactive power is given by

$$Q = \frac{V_1(V_1 - V_2)}{X}$$

A capacitor connected on the DC side of the VSC acts as a DC voltage source. In steady state the voltage V_2 has to be phase shifted slightly behind V_1 in order to compensate for transformer and VSC losses and to keep the capacitor charged. Two VSC technologies can be used for the VSC:

- VSC using GTO-based square-wave inverters and special interconnection transformers. Typically four three-level inverters are used to build a 48-step voltage waveform. Special interconnection transformers are used to neutralize harmonics contained in the square waves generated by individual inverters. In this type of VSC, the fundamental component of voltage V_2 is proportional to the voltage V_{dc} . Therefore V_{dc} has to be varied for controlling the reactive power.
- VSC using IGBT-based PWM inverters. This type of inverter uses Pulse-Width Modulation (PWM) technique to synthesize a sinusoidal waveform from a DC voltage source with a typical chopping frequency of a few kilohertz. Harmonic voltages are cancelled by connecting filters at the AC side of the VSC. This type of VSC uses a fixed DC voltage V_{dc} . Voltage V_2 is varied by changing the modulation index of the PWM modulator.

The STATCOM (Phasor Type) block models an IGBT-based STATCOM (fixed DC voltage). However, as details of the inverter and harmonics are not represented, it can be also used to model a GTO-based STATCOM in transient stability studies. A detailed model of a GTO-based STATCOM is provided in the FACTS demo library (`power_statcom_gto48p demo`).

The figure below shows a single-line diagram of the STATCOM and a simplified block diagram of its control system.

Static Synchronous Compensator (Phasor Type)

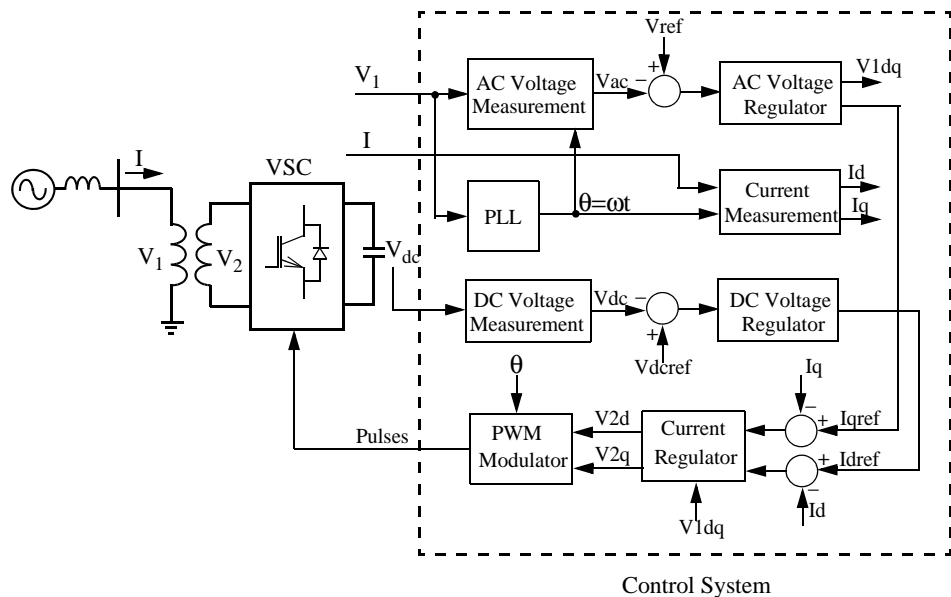

Single-line Diagram of a STATCOM and Its Control System Block Diagram

The control system consists of:

- A phase-locked loop (PLL) which synchronizes on the positive-sequence component of the three-phase primary voltage V_1 . The output of the PLL (angle $\theta = \omega t$) is used to compute the direct-axis and quadrature-axis components of the AC three-phase voltage and currents (labeled as V_d , V_q or I_d , I_q on the diagram).
- Measurement systems measuring the d and q components of AC positive-sequence voltage and currents to be controlled as well as the DC voltage V_{dc} .
- An outer regulation loop consisting of an AC voltage regulator and a DC voltage regulator. The output of the AC voltage regulator is the reference current I_{qref} for the current regulator (I_q = current in quadrature with voltage which controls reactive power flow). The output of the DC voltage regulator is the reference current I_{dref} for the current regulator (I_d = current in phase with voltage which controls active power flow).

Static Synchronous Compensator (Phasor Type)

- An inner current regulation loop consisting of a current regulator. The current regulator controls the magnitude and phase of the voltage generated by the PWM converter (V2d V2q) from the Idref and Iqref reference currents produced respectively by the DC voltage regulator and the AC voltage regulator (in voltage control mode). The current regulator is assisted by a feed forward type regulator which predicts the V2 voltage output (V2d V2q) from the V1 measurement (V1d V1q) and the transformer leakage reactance.

The STATCOM block is a phasor model which does not include detailed representations of the power electronics. You must use it with the phasor simulation method, activated with the Powergui block. It can be used in three-phase power systems together with synchronous generators, motors, dynamic loads and other FACTS and DR systems to perform transient stability studies and observe impact of the STATCOM on electromechanical oscillations and transmission capacity at fundamental frequency.

STATCOM V-I Characteristic

The STATCOM can be operated in two different modes:

- In voltage regulation mode (the voltage is regulated within limits as explained below)
- In var control mode (the STATCOM reactive power output is kept constant)

When the STATCOM is operated in voltage regulation mode, it implements the following V-I characteristic.

Static Synchronous Compensator (Phasor Type)

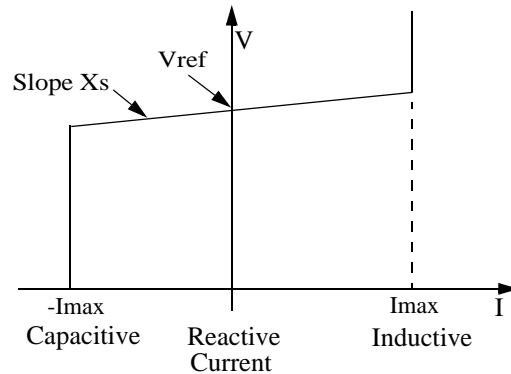

STATCOM V-I characteristic

As long as the reactive current stays within the minimum and maximum current values ($-I_{max}$, I_{max}) imposed by the converter rating, the voltage is regulated at the reference voltage V_{ref} . However, a voltage droop is normally used (usually between 1% and 4% at maximum reactive power output), and the V-I characteristic has the slope indicated in the figure. In the voltage regulation mode, the V-I characteristic is described by the following equation:

$$V = V_{ref} + X_s \cdot I$$

where

V	Positive sequence voltage (p.u.)
I	Reactive current (p.u./ P_{nom}) ($I > 0$ indicates an inductive current)
X_s	Slope or droop reactance (p.u./ P_{nom})
P_{nom}	Three-phase nominal power of the converter specified in the block dialog box

Static Synchronous Compensator (Phasor Type)

STATCOM vs SVC

The STATCOM performs the same function as the SVC. However at voltages lower than the normal voltage regulation range, the STATCOM can generate more reactive power than the SVC. This is due to the fact that the maximum capacitive power generated by a SVC is proportional to the square of the system voltage (constant susceptance) while the maximum capacitive power generated by a STATCOM decreases linearly with voltage (constant current). This ability to provide more capacitive reactive power during a fault is one important advantage of the STATCOM over the SVC. In addition, the STATCOM will normally exhibit a faster response than the SVC because with the VSC, the STATCOM has no delay associated with the thyristor firing (in the order of 4 ms for a SVC).

Dialog Box and Parameters

The STATCOM parameters are grouped in two categories: Power data and Control parameters. Use the **Display** listbox to select which group of parameters you want to visualize.

Power Data Parameters

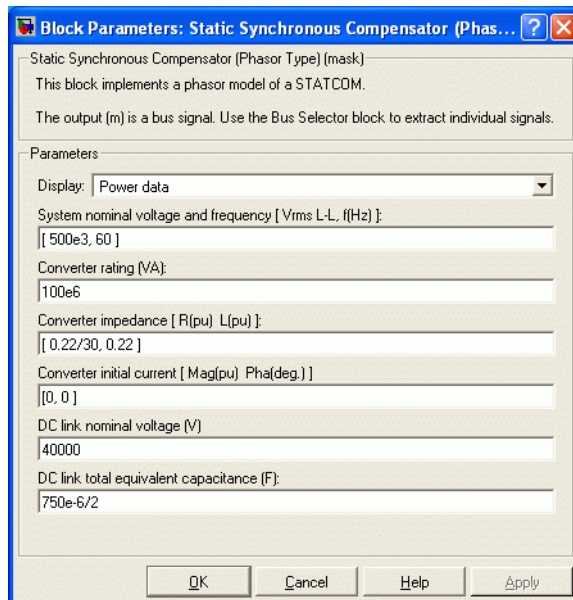

Static Synchronous Compensator (Phasor Type)

System nominal voltage and frequency [Vrms f]

The nominal line-to-line voltage in Vrms and the nominal system frequency in hertz.

Converter rating Snom

The nominal power of the converter in VA.

Converter impedance [R L]

The positive-sequence resistance and inductance of the converter, in p.u. based on the nominal power and voltage ratings. R and L represent the resistance and leakage inductance of the coupling transformer and the resistance and inductance of the series filtering inductors connected at the VSC output.

Converter initial current [Mag Phase]

The initial value of the positive-sequence current phasor (Magnitude in pu and Phase in degrees). If you know the initial value of the current corresponding to the STATCOM operating point you may specify it in order to start simulation in steady state. If you don't know this value, you can leave [0 0]. The system will reach steady-state after a short transient.

DC link nominal voltage

The nominal voltage of the DC link in volts.

DC link total equivalent capacitance

The total capacitance of the DC link in farads. This capacitance value is related to the STATCOM rating and to the DC link nominal voltage. The energy stored in the capacitance (in joules) divided by the STATCOM rating (in VA) is a time duration which is usually a fraction of a cycle at nominal frequency. For example, for the default parameters, ($C=375 \mu\text{F}$, $V_{dc}=40\,000 \text{ V}$, $S_{nom}=100 \text{ MVA}$) this ratio $(1/2 \times C \times V_{dc}^2)/(S_{nom})$ is 3.0 ms, which represents 0.18 cycle for a 60 Hz frequency. If you change the default values of the nominal power rating and DC voltage, you should change the capacitance value accordingly.

Static Synchronous Compensator (Phasor Type)

Control Parameters

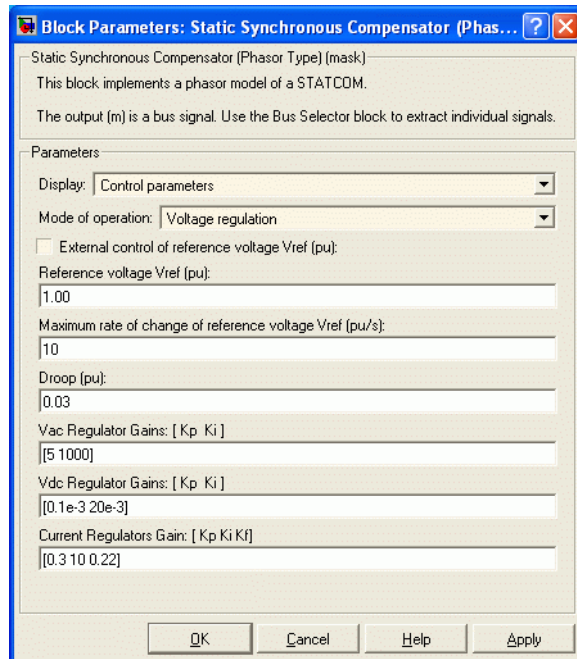

Mode of operation

Specifies the STATCOM mode of operation. Select either Voltage regulation or Var Control.

External control of reference voltage Vref

If this parameter is checked, a Simulink input named Vref appears on the block, allowing to control the reference voltage from an external signal (in p.u.). Otherwise a fixed reference voltage is used, as specified by the parameter below.

Reference voltage Vref

This parameter is not visible when the **Mode of operation** parameter is set to Var Control or when the **External control of reference voltage Vref** parameter is checked.

Reference voltage, in p.u., used by the voltage regulator.

Static Synchronous Compensator (Phasor Type)

Maximum rate of change of reference voltage V_{ref}

This parameter is not visible when the **Mode of operation** parameter is set to Var Control.

Maximum rate of change of the reference voltage, in p.u./s, when an external reference voltage is used.

Droop (pu):

This parameter is not visible when the **Mode of operation** parameter is set to Var Control.

Droop reactance, in p.u./converter rating S_{nom} , defining the slope of the V-I characteristic.

Vac Regulator Gains: [Kp Ki]

This parameter is not visible when the **Mode of operation** parameter is set to Var Control.

Gains of the AC voltage PI regulator. Specify proportional gain K_p in (p.u. of I)/(p.u. of V), and integral gain K_i , in (p.u. of I)/(p.u. of V)/s, where V is the AC voltage error and I is the output of the voltage regulator.

Reactive power setpoint Q_{ref}

This parameter is not visible when the **Mode of operation** parameter is set to Voltage Control.

Reference reactive power, in p.u., when the STATCOM is in Var Control.

Maximum rate of change of reactive power setpoint Q_{ref}

This parameter is not visible when the **Mode of operation** parameter is set to Voltage Control.

Maximum rate of change of the reference reactive power, in p.u./s.

Vdc Regulator Gains: [Kp Ki]

Gains of the DC voltage PI regulator which controls the voltage across the DC bus capacitor. Specify proportional gain K_p in (p.u. of I)/Vdc, and integral gain K_i , in (p.u. of I)/Vdc/s, where Vdc is the DC voltage error and I is the output of the voltage regulator.

Static Synchronous Compensator (Phasor Type)

Current Regulators Gains: [Kp Ki Kf]

Gains of the inner current regulation loop.

Specify proportional gain K_p in (p.u. of V)/(p.u. of I), integral gain K_i , in (p.u. of V)/(p.u. of I)/s, and feed forward gain K_f in (p.u. of V)/(p.u. of I), where V is the output V_{2d} or V_{2q} of the current regulator and I is the I_d or I_q current error.

For optimal performance, the feed forward gain should be set to the converter reactance (in p.u.) given by parameter L in the **Converter impedance [R L]** parameters.

Inputs and Outputs

A B C

The three terminals of the STATCOM.

Trip

Apply a simulink logical signal (0 or 1) to this input. When this input is high the STATCOM is disconnected and its control system is disabled. Use this input to implement a simplified version of the protection system.

Vref

Simulink input of the external reference voltage signal.

This input is visible only the **External control of reference voltage Vref** parameter is checked.

Static Synchronous Compensator (Phasor Type)

m

Simulink output vector containing 16 STATCOM internal signals. These signals are either voltage and current phasors (complex signals) or control signals. They can be individually accessed by using the Bus Selector block. They are, in order:

Signal	Signal Group	Signal Names	Definition
1-3	Power Vabc (cmplx)	Va_prim (pu) Vb_prim (pu) Vc_prim (pu)	Phasor voltages (phase to ground) Va, Vb, Vc at the STATCOM primary terminals (p.u.)
4-6	Power Iabc (cmplx)	Ia_prim (pu) Ib_prim (pu) Ic_prim (pu)	Phasor currents Ia, Ib, Ic flowing into the STATCOM (p.u.)
7	Power	Vdc (V)	DC voltage (V)
8	Control	Vm (pu)	Positive-sequence value of the measured voltage (p.u.)
9	Control	Vref (pu)	Reference voltage (p.u.)
10	Control	Qm (pu)	STATCOM reactive power. A positive value indicates inductive operation.
11	Control	Qref (pu)	Reference reactive power (p.u.)

Static Synchronous Compensator (Phasor Type)

Signal (Conti)	Signal Group	Signal Names	Definition (Continued)
12	Control	Id (pu)	Direct-axis component of current (active current) flowing into STATCOM (p.u.). A positive value indicates active power flowing into STATCOM.
13	Control	Iq (pu)	Quadrature-axis component of current (reactive current) flowing into STATCOM (p.u.). A positive value indicates capacitive operation.
14	Control	Idref (pu)	Reference value of direct-axis component of current flowing into STATCOM (p.u.)
15	Control	Iqref (pu)	Reference value of quadrature-axis component of current flowing into STATCOM (p.u.)
16	Control	modindex	The modulation index m of the PWM modulator. A positive number $0 < m < 1$. $m=1$ corresponds to the maximum voltage V_2 which can be generated by the VSC without overmodulation.

Example

See the `power_statcom` demo which illustrates the steady-state and dynamic performance of a STATCOM regulating voltage on a 500 kV, 60 Hz, system. The demo also compares the performance of the STACOM with an SVC having the same rating.

References

[1] N. G. Hingorani, L. Gyugyi, "Understanding FACTS; Concepts and Technology of Flexible AC Transmission Systems," IEEE Press book, 2000.

See Also

Static Var Compensator (Phasor Type), Unified Power Flow Controller (Phasor Type)

Static Synchronous Series Compensator (Phasor Type)

Purpose

Implements a phasor model of a three-phase static synchronous series compensator

Library

Flexible AC Transmission Systems (FACTS)/Power-Electronics Based FACTS

Description

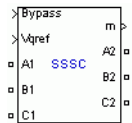

The Static Synchronous Series Compensator (SSSC) is a series device of the Flexible AC Transmission Systems (FACTS) family using power electronics to control power flow and improve power oscillation damping on power grids [1]. The SSSC injects a voltage V_s in series with the transmission line where it is connected.

Static Synchronous Series Compensator (Phasor Type)

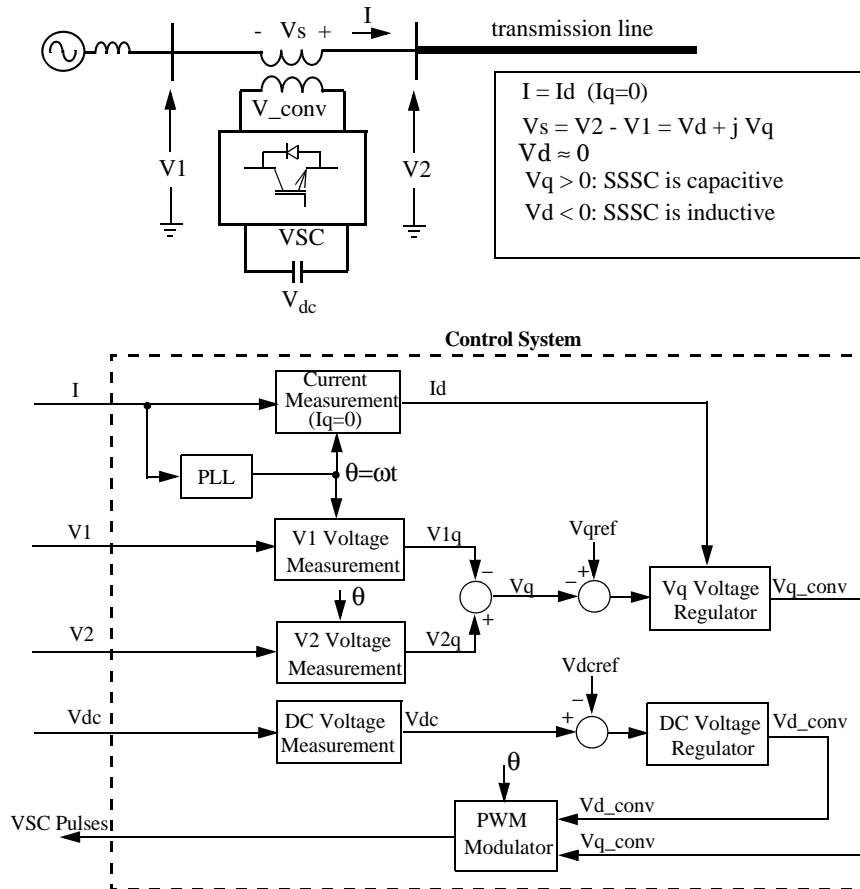

Single-line Diagram of a SSSC and Its Control System Block Diagram

As the SSSC does not use any active power source, the injected voltage must stay in quadrature with line current. By varying the magnitude V_q of the injected voltage in quadrature with current, the SSSC performs the function of a variable reactance compensator, either capacitive or inductive.

The variation of injected voltage is performed by means of a Voltage-Sourced Converter (VSC) connected on the secondary side of a coupling transformer.

Static Synchronous Series Compensator (Phasor Type)

The VSC uses forced-commutated power electronic devices (GTOs, IGBTs or IGCTs) to synthesize a voltage V_{conv} from a DC voltage source.

A capacitor connected on the DC side of the VSC acts as a DC voltage source. A small active power is drawn from the line to keep the capacitor charged and to provide transformer and VSC losses, so that the injected voltage V_s is practically 90 degrees out of phase with current I . In the control system block diagram $V_{d,conv}$ and $V_{q,conv}$ designate the components of converter voltage V_{conv} which are respectively in phase and in quadrature with current. Two VSC technologies can be used for the VSC:

- VSC using GTO-based square-wave inverters and special interconnection transformers. Typically four three-level inverters are used to build a 48-step voltage waveform. Special interconnection transformers are used to neutralize harmonics contained in the square waves generated by individual inverters. In this type of VSC, the fundamental component of voltage V_{conv} is proportional to the voltage V_{dc} . Therefore V_{dc} has to varied for controlling the injected voltage.
- VSC using IGBT-based PWM inverters. This type of inverter uses Pulse-Width Modulation (PWM) technique to synthesize a sinusoidal waveform from a DC voltage with a typical chopping frequency of a few kilohertz. Harmonics are cancelled by connecting filters at the AC side of the VSC. This type of VSC uses a fixed DC voltage V_{dc} . Voltage V_{conv} is varied by changing the modulation index of the PWM modulator.

The SSSC (Phasor Type) block models an IGBT-based SSSC (fixed DC voltage). However, as details of the inverter and harmonics are not represented, it can be also used to model a GTO-based SSSC in transient stability studies.

The control system consists of:

- A phase-locked loop (PLL) which synchronizes on the positive-sequence component of the current I . The output of the PLL (angle $\theta = \omega t$) is used to compute the direct-axis and quadrature-axis components of the AC three-phase voltages and currents (labeled as V_d , V_q or I_d , I_q on the diagram).
- Measurement systems measuring the q components of AC positive-sequence of voltages V_1 and V_2 (V_{1q} and V_{2q}) as well as the DC voltage V_{dc} .
- AC and DC voltage regulators which compute the two components of the converter voltage ($V_{d,conv}$ and $V_{q,conv}$) required to obtain the desired DC

Static Synchronous Series Compensator (Phasor Type)

voltage (V_{dref}) and the injected voltage (V_{qref}). The V_q voltage regulator is assisted by a feed forward type regulator which predicts the V_{conv} voltage from the I_d current measurement.

The SSSC block is a phasor model which does not include detailed representations of the power electronics. You must use it with the phasor simulation method, activated with the Powergui block. It can be used in three-phase power systems together with synchronous generators, motors, dynamic loads and other FACTS and DR systems to perform transient stability studies and observe impact of the SSSC on electromechanical oscillations and transmission capacity at fundamental frequency.

Dialog Box and Parameters

The SSSC parameters are grouped in two categories: Power data and Control parameters. Use the **Display** listbox to select which group of parameters you want to visualize.

Power Data Parameters

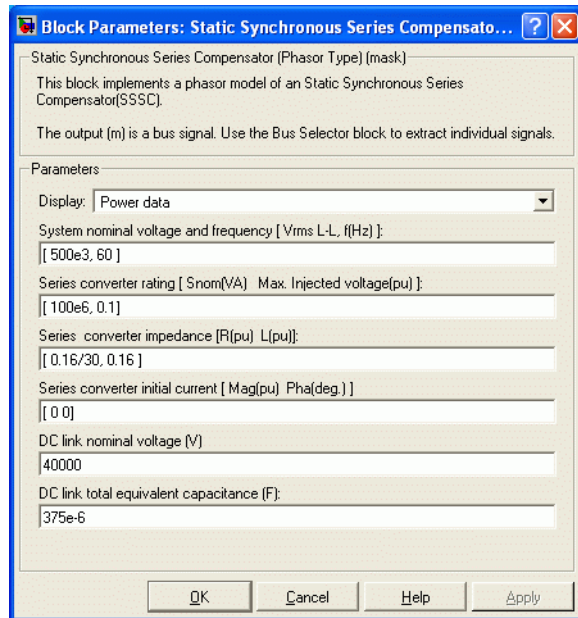

System nominal voltage and frequency [Vrms f]

The nominal line-to-line voltage in Vrms and the nominal system frequency in hertz.

Static Synchronous Series Compensator (Phasor Type)

Series converter rating [Snom, Max. Injected voltage]

The nominal rating of the series converter in VA and the maximum value of the injected voltage V_{conv} on the VSC side of the transformer (see single line diagram), in p.u. of nominal phase-to-ground voltage.

Series converter impedance [R L]

The positive-sequence resistance and inductance of the converter, in p.u. based on the nominal converter rating and nominal voltage. R and L represent the resistance and leakage inductance of the coupling transformer plus the resistance and inductance of the series filtering inductors connected at the VSC output.

Series converter initial current [Mag Phase]

The initial value of the positive-sequence current phasor (Magnitude in p.u. and Phase in degrees). If you know the initial value of the current corresponding to the SSSC operating point you may specify it in order to start simulation in steady state. If you don't know this value, you can leave [0 0]. The system will reach steady-state after a short transient.

DC link nominal voltage

The nominal voltage of the DC link in volts.

DC link total equivalent capacitance

The total capacitance of the DC link in farads. This capacitance value is related to the SSSC converter rating and to the DC link nominal voltage. The energy stored in the capacitance (in joules) divided by the converter rating (in VA) is a time duration which is usually a fraction of a cycle at nominal frequency. For example, for the default parameters, ($C=375 \mu\text{F}$, $V_{dc}=40\,000 \text{ V}$, $S_{nom}=100 \text{ MVA}$) this ratio $(1/2 \times C \cdot V_{dc}^2) / (S_{nom})$ is 3.0 ms, which represents 0.18 cycle for a 60 Hz frequency. If you change the default values of the nominal power rating and DC voltage, you should change the capacitance value accordingly.

Static Synchronous Series Compensator (Phasor Type)

Control Parameters

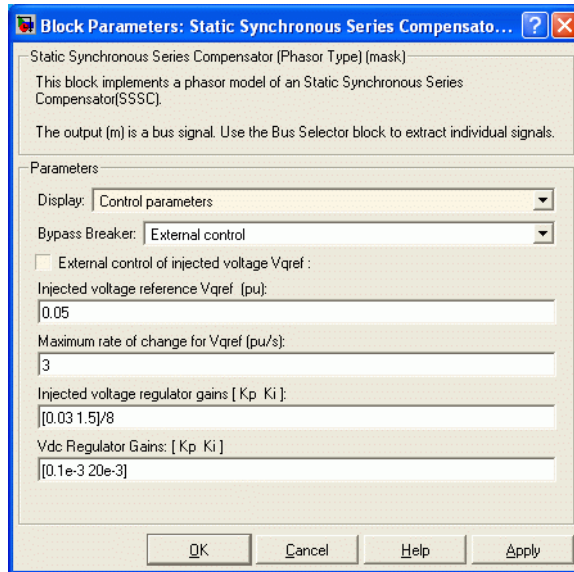

Bypass Breaker

Specifies the status of the bypass breaker connected inside the block across terminals A1, B1, C1 and A2, B2, C2. Select either **External Control**, **Open** or **Closed**. If the bypass breaker is in external control, a Simulink input named **Bypass** appears on the block, allowing to control the status of the bypass breaker from an external signal (0 or 1).

External control of injected voltage Vqref

If this parameter is checked, a Simulink input named **Vqref** appears on the block, allowing to control the injected voltage from an external signal (in p.u.). Otherwise a fixed reference voltage is used, as specified by the parameter below.

Injected voltage reference Vqref

This parameter is not visible when the **External control of injected voltage Vqref** parameter is checked.

Specify the quadrature-axis component of the voltage injected on the VSC side of the series transformer, in p.u.

Static Synchronous Series Compensator (Phasor Type)

Maximum rate of change for Vqref

Maximum rate of change of the Vqref voltage, in p.u./s.

Injected voltage regulator gains: [Kp Ki]

Gains of the PI regulator which controls the injected voltage. Specify proportional gain Kp in (p.u. of Vq_conv)/(p.u. of V), and integral gain Ki, in (p.u. of Vq_conv)/(p.u. of V)/s, where V is the Vq voltage error and Vq_conv is the quadrature-axis component of the voltage generated by the VSC.

The feed forward gain is computed from the **Series converter impedance [R L]** parameters.

Vdc regulator gains: [Kp Ki]

Gains of the DC voltage PI regulator which controls the voltage across the DC bus capacitor. Specify proportional gain Kp in (p.u. of Vd_conv)/Vdc, and integral gain Ki, in (p.u. of Vd_conv)/Vdc/s, where Vdc is the DC voltage error and Vd_conv is the direct-axis component of the voltage generated by the converter.

Inputs and Outputs

A1 B1 C1

The three input terminals of the SSSC.

A2 B2 C2

The three output terminals of the SSSC.

Bypass

This input is visible only when the **Bypass Breaker** parameter is set to External Control.

Apply a simulink logical signal (0 or 1) to this input. When this input is high the bypass breaker is closed.

Vqref

This input is visible only when the **External control of injected voltage Vqref** parameter is checked.

Apply a simulink signal specifying the reference voltage, in p.u.

m

Simulink output vector containing 17 SSSC internal signals. These signals are either voltage and current phasors (complex signals) or control signals.

Static Synchronous Series Compensator (Phasor Type)

They can be individually accessed by using the Bus Selector block. They are, in order:

Signal I	Signal Group	Signal Names	Definition
1-3	Power Vabc1 (cplx)	Va1 (pu) Vb1 (pu) Vc1 (pu)	Phasor voltages (phase to ground) Va, Vb, Vc at the SSSC input terminals A1, B1, C1 (p.u.)
4	Power	Vdc (V)	DC voltage (V)
5-7	Power Vabc2 (cplx)	Va2 (pu) Vb2 (pu) Vc2 (pu)	Phasor voltages (phase to ground) Va, Vb, Vc at the SSSC output terminals A2, B2, C2 (p.u.)
8-10	Power Vabc_In j (cplx)	Va_Inj (pu) Vb_Inj (pu) Vc_Inj (pu)	Phasors of injected voltages $V_s = V_2 - V_1$ (p.u.)
11-13	Power Iabc (cplx)	Ia (pu) Ib (pu) Ic (pu)	Phasor currents Ia, Ib, Ic flowing out of terminals A2, B2, C2 (p.u.)
14	Control	Vqref (pu)	Reference value of quadrature-axis injected voltage (p.u.)
15	Control	Vqinj (pu)	Measured injected voltage in quadrature-axis (p.u.)
16	Control	Id(pu)	Measured current (p.u.)
17	Control	modindex	The modulation index m of the PWM modulator. A positive number $0 < m < 1$. m=1 corresponds to the maximum voltage V_conv which can be generated by the series converter without overmodulation.

Static Synchronous Series Compensator (Phasor Type)

- Example** See the power_sssc demo which illustrates the use of a SSSC for damping power oscillations on a 500 kV, 60 Hz, system.
- References** [1] N. G. Hingorani, L. Gyugyi, "Understanding FACTS; Concepts and Technology of Flexible AC Transmission Systems," IEEE Press book, 2000
- See Also** Unified Power Flow Controller (Phasor Type)

Static Var Compensator (Phasor Type)

Purpose

Implements a phasor model of a three-phase static var compensator

Library

Flexible AC Transmission Systems (FACTS)/Power-Electronics Based FACTS

Description

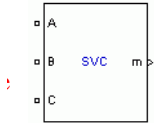

The Static Var Compensator (SVC) is a shunt device of the Flexible AC Transmission Systems (FACTS) family using power electronics to control power flow and improve transient stability on power grids [1]. The SVC regulates voltage at its terminals by controlling the amount of reactive power injected into or absorbed from the power system. When system voltage is low, the SVC generates reactive power (SVC capacitive). When system voltage is high, it absorbs reactive power (SVC inductive). The variation of reactive power is performed by switching three-phase capacitor banks and inductor banks connected on the secondary side of a coupling transformer. Each capacitor bank is switched on and off by three thyristor switches (Thyristor Switched Capacitor or TSC). Reactors are either switched on-off (Thyristor Switched Reactor or TSR) or phase-controlled (Thyristor Controlled Reactor or TCR).

The figure below shows a single-line diagram of a static var compensator and a simplified block diagram of its control system.

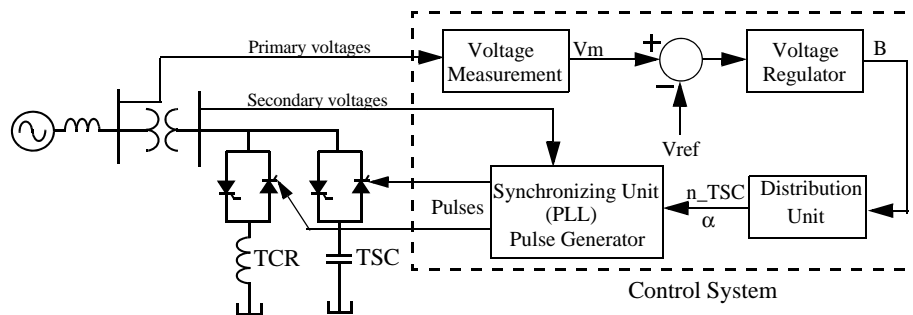

Single-line Diagram of an SVC and Its Control System Block Diagram

The control system consists of

- A measurement system measuring the positive-sequence voltage to be controlled. A Fourier-based measurement system using a one-cycle running average is used.

Static Var Compensator (Phasor Type)

- A voltage regulator that uses the voltage error (difference between the measured voltage V_m and the reference voltage V_{ref}) to determine the SVC susceptance B needed to keep the system voltage constant
- A distribution unit that determines the TSCs (and eventually TSRs) that must be switched in and out, and computes the firing angle α of TCRs
- A synchronizing system using a phase-locked loop (PLL) synchronized on the secondary voltages and a pulse generator that send appropriate pulses to the thyristors

The SVC (Phasor Type) block is a phasor model, and you must use it with the phasor simulation method, activated with the Powergui block. It can be used in three-phase power systems together with synchronous generators, motors, and dynamic loads to perform transient stability studies and observe impact of the SVC on electromechanical oscillations and transmission capacity. This model does not include detailed representations of the power electronics, the measurement system, or the synchronization system. These systems are approximated rather by simple transfer functions that yield a correct representation at the system's fundamental frequency.

A detailed model of a SVC using three TSCs and one TCR is provided in the `power_svc_1tcr3tsc` demo.

SVC V-I Characteristic

The SVC can be operated in two different modes:

- In voltage regulation mode (the voltage is regulated within limits as explained below)
- In var control mode (the SVC susceptance is kept constant)

When the SVC is operated in voltage regulation mode, it implements the following V-I characteristic.

Static Var Compensator (Phasor Type)

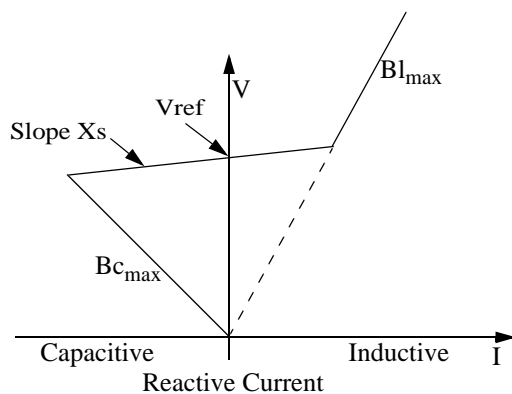

SVC V-I characteristic

As long as the SVC susceptance B stays within the maximum and minimum susceptance values imposed by the total reactive power of capacitor banks ($B_{c_{max}}$) and reactor banks ($B_{l_{max}}$), the voltage is regulated at the reference voltage V_{ref} . However, a voltage droop is normally used (usually between 1% and 4% at maximum reactive power output), and the V-I characteristic has the slope indicated in the figure. The V-I characteristic is described by the following three equations:

$$V = V_{ref} + X_s \cdot I \quad \text{SVC is in regulation range } (-B_{c_{max}} < B < B_{l_{max}})$$

$$V = -\frac{I}{B_{c_{max}}} \quad \text{SVC is fully capacitive } (B = B_{c_{max}})$$

$$V = \frac{I}{B_{l_{max}}} \quad \text{SVC is fully inductive } (B = B_{l_{max}})$$

where

V Positive sequence voltage (p.u.)

I Reactive current (p.u./Pbase) ($I > 0$ indicates an inductive current)

X_s Slope or droop reactance (p.u./Pbase)

Static Var Compensator (Phasor Type)

B _{max}	Maximum capacitive susceptance (p.u./Pbase) with all TSCs in service, no TSR or TCR
B _{lmax}	Maximum inductive susceptance (p.u./Pbase) with all TSRs in service or TCRs at full conduction, no TSC
P _{base}	Three-phase base power specified in the block dialog box

SVC Dynamic Response

When the SVC is operating in voltage regulation mode, its response speed to a change of system voltage depends on the voltage regulator gains (proportional gain K_p and integral gain K_i), the droop reactance X_s , and the system strength (short-circuit level).

For an integral-type voltage regulator ($K_p = 0$), if the voltage measurement time constant T_m and the average time delay T_d due to valve firing are neglected, the closed-loop system consisting of the SVC and the power system can be approximated by a first-order system having the following closed-loop time constant:

$$T_c = \frac{1}{K_i \cdot (X_s + X_n)}$$

where

T _c	Closed loop time constant
K _i	Proportional gain of the voltage regulator (p.u._B/p.u._V/s)
X _s	Slope reactance p.u./Pbase
X _n	Equivalent power system reactance (p.u./Pbase)

This equation demonstrates that you obtain a faster response speed when the regulator gain is increased or when the system short-circuit level decreases (higher X_n values). If you take into account the time delays due to voltage measurement system and valve firing, you obtain an oscillatory response and, eventually, an instability with too weak a system or too large a regulator gain.

Dialog Box and Parameters

The SVC parameters are grouped in two categories: Power Data and Control Parameters. Use the **Display** listbox to select which group of parameters you want to visualize.

Static Var Compensator (Phasor Type)

Power Data Parameters

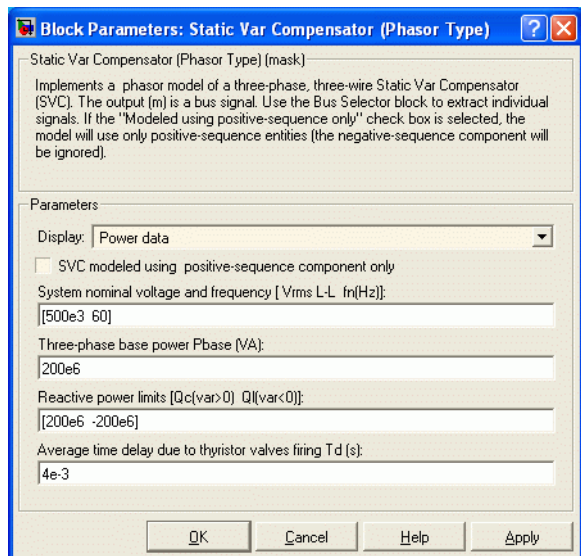

SVC modeled using positive-sequence only

The SVC is modeled by a three-wire system using two current sources. The SVC does not generate any zero-sequence current, but it can generate negative-sequence currents during unbalanced system operation. The negative-sequence susceptance of the SVC is assumed to be identical to its positive-sequence value, as determined by the B value computed by the voltage regulator.

Check this box to ignore negative-sequence current.

System nominal voltage and frequency [Vrms f]

The nominal line-to-line voltage in Vrms and the nominal system frequency in hertz.

Three-phase base power Pbase

Three-phase base power, in VA, used to specify the following parameters in p.u.: droop reactance Xs, gains Kp and Ki of the voltage PI regulator, and reference susceptance Bref. This base power is also used to normalize the output B susceptance signal.

Static Var Compensator (Phasor Type)

Reactive power limits [Q_c Q_l]

The maximum SVC reactive powers at 1 p.u. voltage, in vars. Enter a positive value for the capacitive reactive power Q_c (vars generated by the SVC) and a negative value for the inductive reactive power Q_l (vars absorbed by the SVC).

Average time delay due to thyristor valves firing T_d

Average time delay simulating the non instantaneous variation of thyristor fundamental current when the distribution unit sends a switching order to the pulse generator. Because pulses have to be synchronized with thyristor commutation voltages, this delay normally varies between 0 and 1/2 cycle. The suggested average value is 4 ms.

Control Parameters

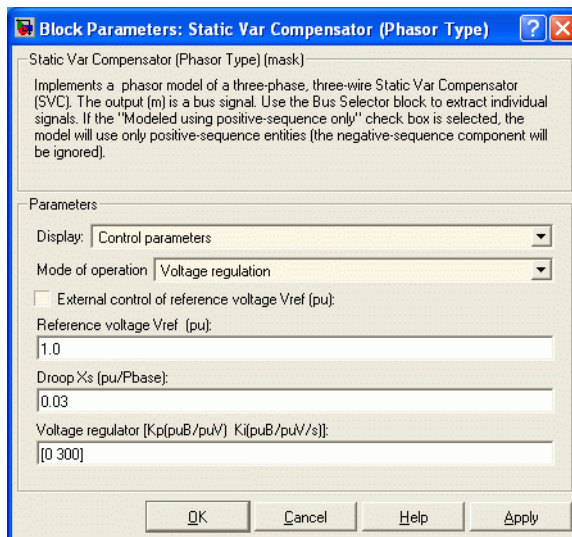

Mode of operation

Specifies the SVC mode of operation. Select either Voltage regulation or Var control (Fixed susceptance B_{ref}).

External control of reference voltage V_{ref}

If this parameter is checked, a Simulink input named V_{ref} appears on the block, allowing to control the reference voltage from an external signal (in

Static Var Compensator (Phasor Type)

p.u.). Otherwise a fixed reference voltage is used, as specified by the parameter below.

Reference voltage Vref

This parameter is not visible when the **Mode of operation** parameter is set to `Var Control` or when the **External control of reference voltage Vref** parameter is checked

Reference voltage, in p.u., used by the voltage regulator.

Droop Xs

This parameter is not visible when the **Mode of operation** parameter is set to `Var Control`.

Droop reactance, in p.u./Pbase, defining the slope of the V-I characteristic.

Voltage regulator [Kp Ki]

This parameter is not visible when the **Mode of operation** parameter is set to `Var Control`.

Proportional gain, in (p.u. of B)/(p.u. of V), and integral gain, in p.u._B/p.u._V/s, of the voltage regulator.

Bref for var control mode

This parameter is not visible when the **Mode of operation** parameter is set to `Voltage regulation`.

Reference susceptance, in p.u./Pbase, when the SVC is operating in var control mode.

Inputs and Outputs

A B C

The three terminals of the SVC.

Vref

Simulink input of the reference voltage signal.

This input is visible only when the **External control of reference voltage Vref** parameter is checked.

m

Simulink output vector containing six SVC internal signals. These signals are either voltage and current phasors (complex signals) or control signals.

Static Var Compensator (Phasor Type)

They can be individually accessed by using the Bus Selector block. They are, in order:

Signal	Signal Group	Signal Names	Definition
1-3	Power	Ia(pu) Ib(pu) Ic(pu)	Phasor currents Ia, Ib, Ic flowing into the SVC (p.u.)
4	Control	Vm (pu)	Positive-sequence value of measured voltage (p.u.)
5	Control	B (pu)	SVC susceptance output of the voltage regulator (p.u.). A positive value indicates that the SVC is capacitive.
6	Control	Q (pu)	SVC reactive power output (p.u.). A positive value indicates inductive operation.

Example

The power_stacom demo illustrates the steady-state and dynamic performance of a +200 Mvar/- 100 Mvar SVC regulating voltage on a 500 kV, 60 Hz, system.

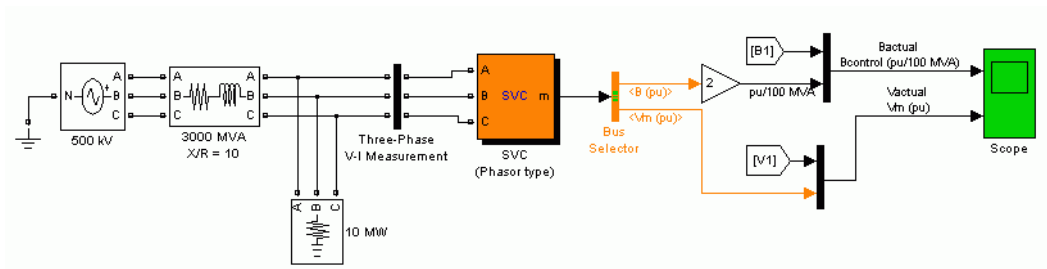

Open the SVC block menu and look at its parameters. The SVC is set to Voltage regulation mode with a reference voltage $V_{ref} = 1.0$ pu. The voltage droop reactance is 0.03 p.u./200 MVA, so that the voltage varies from 0.97 p.u. to 1.015 p.u. when the SVC current goes from fully capacitive to fully inductive. Double-click the blue block to display the SVC V-I characteristic.

Static Var Compensator (Phasor Type)

The Three-Phase Programmable Voltage Source is used to vary the system voltage and observe the SVC performance. Initially the source is generating its nominal voltage (500 kV). Then, voltage is successively decreased (0.97 p.u. at $t = 0.1$ s), increased (1.03 p.u. at $t = 0.4$ s) and finally returned to nominal voltage (1 p.u. at $t = 0.7$ s).

Start the simulation and observe the SVC dynamic response to voltage steps on the Scope. Waveforms are reproduced on the figure below. Trace 1 shows the actual positive-sequence susceptance B1 and control signal output B of the voltage regulator. Trace 2 shows the actual system positive-sequence voltage V1 and output Vm of the SVC measurement system.

Static Var Compensator (Phasor Type)

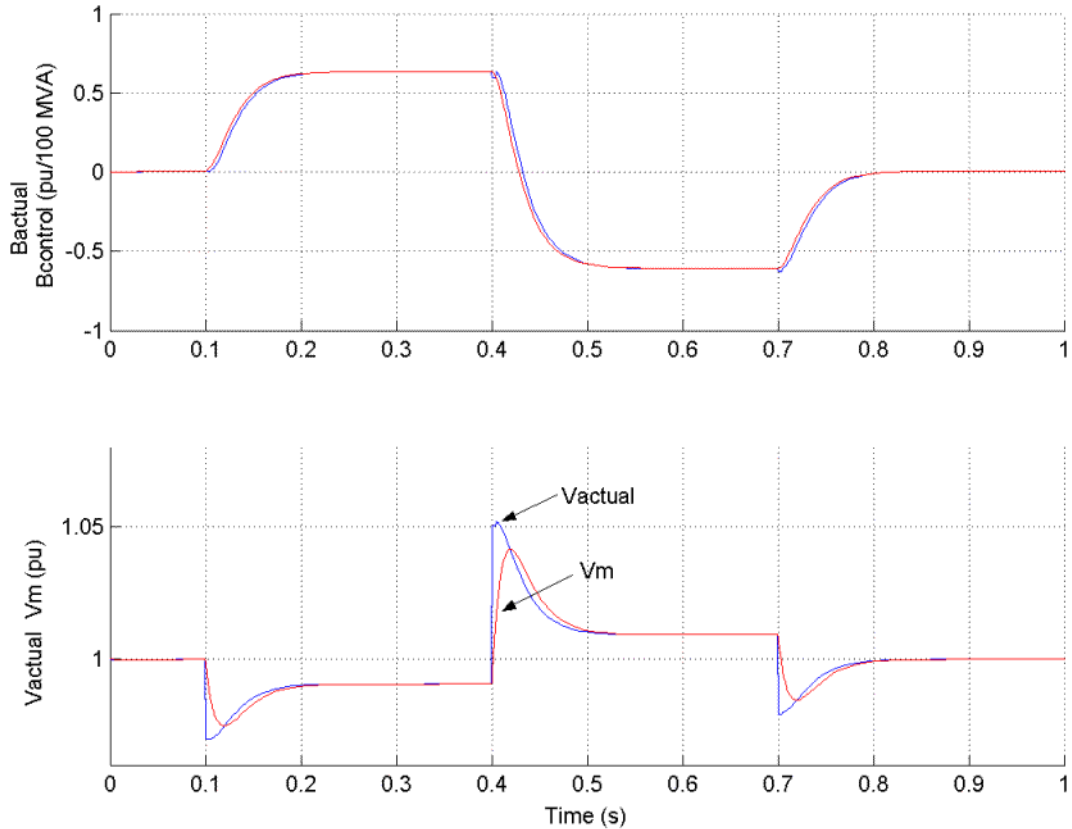

The SVC response speed depends on the voltage regulator integral gain K_i (proportional gain K_p is set to zero), system strength (reactance X_n), and droop (reactance X_s).

As mentioned above, neglecting the voltage measurement time constant T_m and the average time delay T_d due to valve firing, the system can be approximated by a first-order system having a closed-loop time constant:

$$T_c = \frac{1}{K_i \cdot (X_s + X_n)}$$

Static Var Compensator (Phasor Type)

With given system parameters ($K_i = 300$; $X_n = 0.0667$ p.u./200 MVA; $X_s = 0.03$ p.u./200 MVA), the closed-loop time constant is $T_c = 0.0345$ s.

If you increase the regulator gain or decrease the system strength, T_m and T_d are no longer negligible, and you instead observe an oscillatory response and eventually instability. The figure below compares the SVC susceptance (B output of the voltage regulator) for two different short-circuit levels: 3000 VA and 600 MVA.

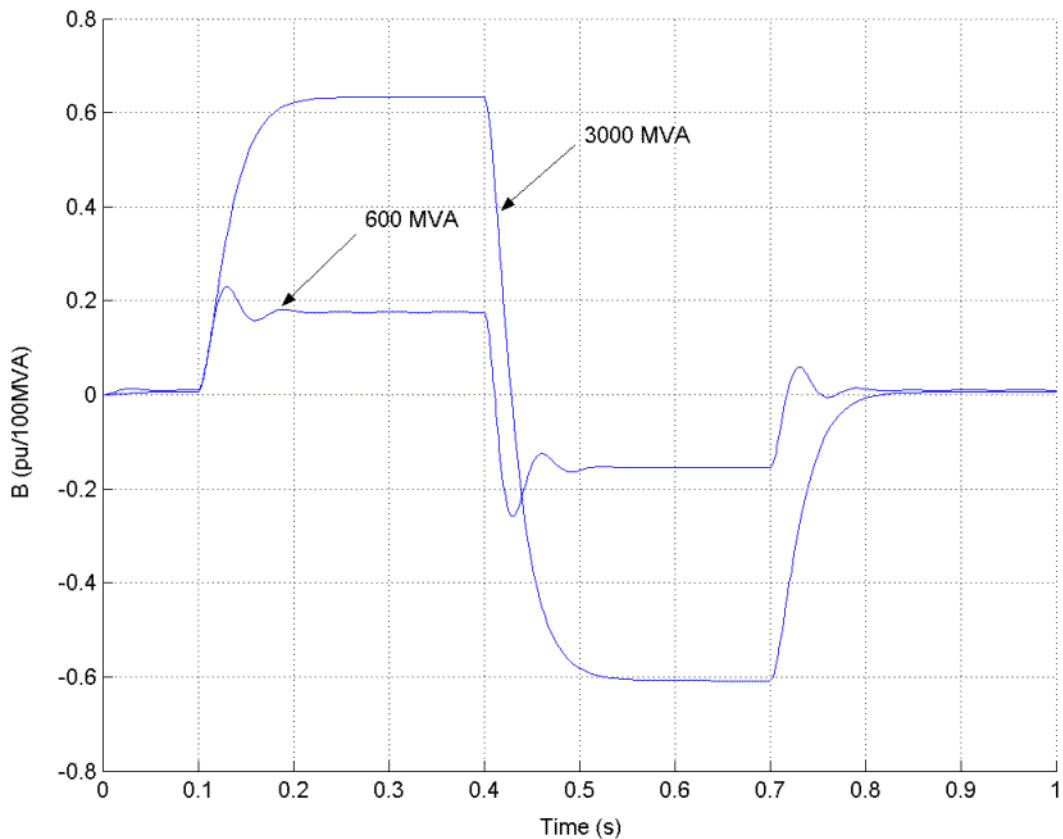

References

[1] N. G. Hingorani, L. Gyugyi, "Understanding FACTS; Concepts and Technology of Flexible AC Transmission Systems," IEEE Press book, 2000

See Also

Static Synchronous Compensator (Phasor Type)

Steam Turbine and Governor

Purpose

Model the dynamics of a speed governing system, steam turbine, and multimass shaft

Library

Machines

Description

The Steam Turbine and Governor block implements a complete tandem-compound steam prime mover, including a speed governing system, a four-stage steam turbine, and a shaft with up to four masses.

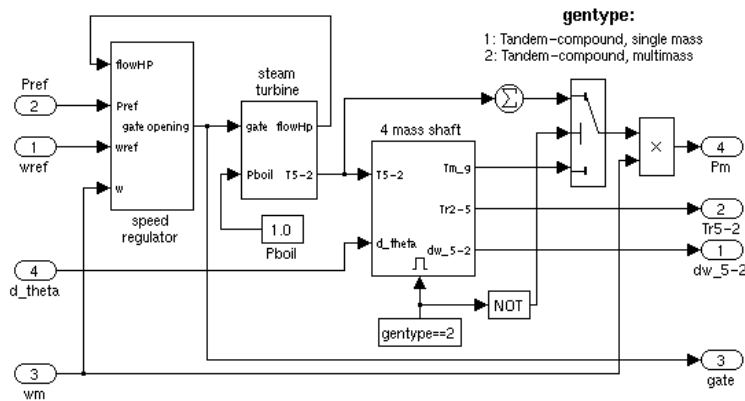

The speed governing system consists of a proportional regulator, a speed relay, and a servomotor controlling the gate opening. It is similar to one of the models proposed in [1].

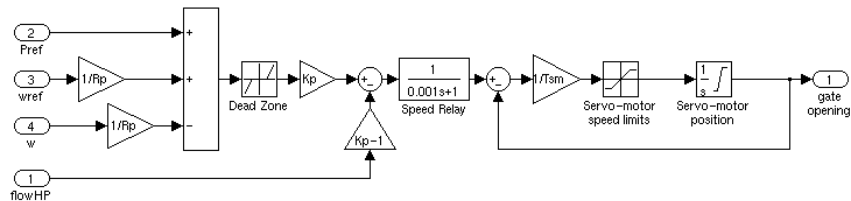

The steam turbine has four stages, each modeled by a first-order transfer function. The first stage represents the steam chest while the three other stages represent either reheaters or crossover piping. The boiler is not modeled

Steam Turbine and Governor

and boiler pressure is constant at 1.0 p.u. Fractions F2 to F5 are used to distribute the turbine power to the various shaft stages:

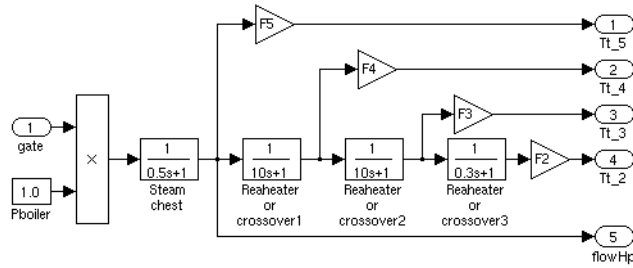

The shaft models a four-mass system, which is coupled to the mass in the Synchronous Machine model for a total of five masses. The machine's mass is labeled mass #1. The mass in the Steam Turbine and Governor block, which is closest to the machine's mass, is mass #2, while the mass farthest from the machine is mass #5. The shaft is characterized by mass inertias H , damping factors D , and rigidity coefficients K . If you choose to simulate a single-mass shaft, the entire four-mass shaft subsystem in the Steam Turbine and Governor block is disabled and all the torque from the turbine is added together and applied to the machine's mass:

Steam Turbine and Governor

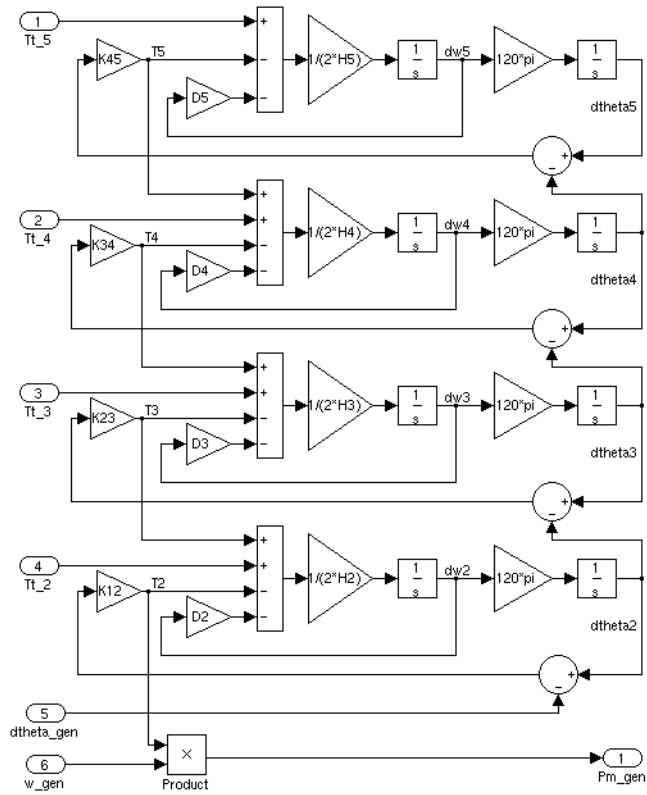

Steam Turbine and Governor

Dialog Box and Parameters

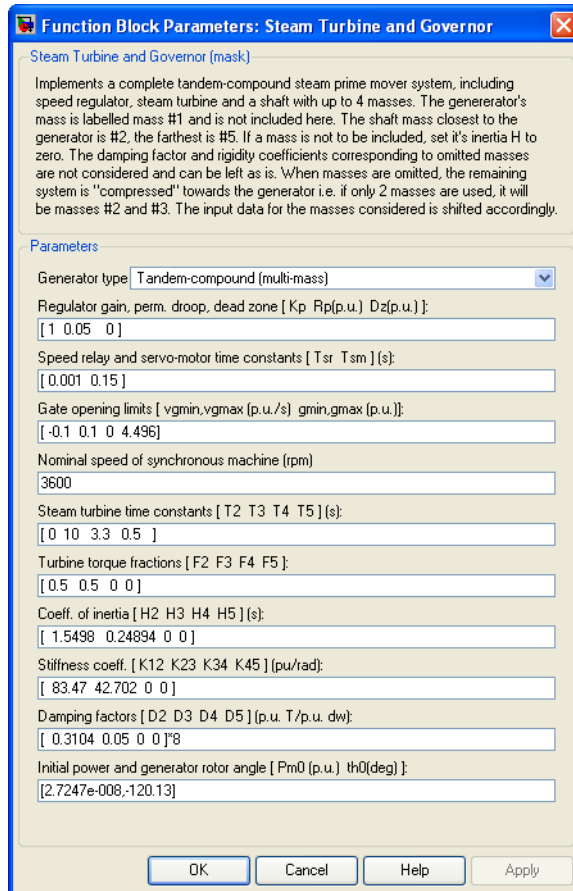

Function Block Parameters: Steam Turbine and Governor

Steam Turbine and Governor (mask)

Implements a complete tandem-compound steam prime mover system, including speed regulator, steam turbine and a shaft with up to 4 masses. The generator's mass is labelled mass #1 and is not included here. The shaft mass closest to the generator is #2, the farthest is #5. If a mass is not to be included, set its inertia H to zero. The damping factor and rigidity coefficients corresponding to omitted masses are not considered and can be left as is. When masses are omitted, the remaining system is "compressed" towards the generator i.e. if only 2 masses are used, it will be masses #2 and #3. The input data for the masses considered is shifted accordingly.

Parameters

Generator type: Tandem-compound (multi-mass)

Regulator gain, perm. droop, dead zone [Kp Rp(p.u.) Dz(p.u.)]:
[1 0.05 0]

Speed relay and servo-motor time constants [Tsr Tsm](s):
[0.001 0.15]

Gate opening limits [vgmin,vgmax (p.u./s) gmin,gmax (p.u.)]:
[-0.1 0.1 0 4.496]

Nominal speed of synchronous machine (rpm):
3600

Steam turbine time constants [T2 T3 T4 T5](s):
[0 10 3.3 0.5]

Turbine torque fractions [F2 F3 F4 F5]:
[0.5 0.5 0 0]

Coeff. of inertia [H2 H3 H4 H5](s):
[1.5498 0.24894 0 0]

Stiffness coeff. [K12 K23 K34 K45](pu/rad):
[83.47 42.702 0 0]

Damping factors [D2 D3 D4 D5](p.u. T/p.u. dw):
[0.3104 0.05 0 0]*8

Initial power and generator rotor angle [Pm0 (p.u.) th0(deg)]:
[2.7247e-008,-120.13]

OK Cancel Help Apply

Generator type

Specifies rotor type: single mass or multimass tandem-compound. If you choose a single-mass system, the multimass shaft subsystem in the Steam Turbine and Governor block is disabled and the turbine's output torques are summed together and applied to the single mass in the Synchronous Machine block.

Regulator gain, permanent droop, dead zone

The gain K_p , permanent droop R_p (p.u.), and dead-zone width D_z (p.u.). Set gain to 3 if you want to use the steam flow feedback loop. Otherwise, set gain to 1.

Speed relay and servo-motor time constants

The speed relay and gate servomotor time constants T_{sr} (s) and T_{sm} (s).

Gate opening limits

The minimum and maximum gate opening speed v_{gmin} and v_{gmax} (both in p.u./s), and minimum and maximum gate opening g_{min} and g_{max} (both in p.u.).

Nominal speed of synchronous machine

The synchronous speed of the generator driven by the steam turbine (rpm).

Steam turbine time constants

The turbine time constants T_2 to T_5 (s). Numbered consistently with turbine torque fractions and mass numbers; i.e., T_5 is the time constant of the first turbine stage, which models the steam chest.

Turbine torque fractions

The turbine torque fractions F_2 to F_5 . Must total 1, otherwise an error message appears. Fraction numbers correspond to mass numbers; i.e., F_2 is the fraction of torque to be applied to mass #2 of the multimass shaft.

Coefficient of inertia; Stiffness coefficient; Damping factors

Only visible if generator type is `multimass`. Coefficients of inertia H_2 to H_5 (s), stiffness coefficients K_{12} to K_{45} (p.u./rad), and damping factors D_2 to D_5 (p.u. torque / p.u. speed deviation) are associated with the masses of the multimass shaft. K_{12} corresponds to the rigidity coefficient between masses #1 and #2, and so on.

Note If you do not want to simulate all four masses in the multimass shaft, simply set the inertia of unwanted masses to 0. The rigidity coefficient and damping factor corresponding to omitted masses are not considered. When masses are not simulated, the remaining system is “compressed” toward the generator; i.e., if only two masses are used (excluding the generator), they are masses #2 and #3. The input data for the masses considered are shifted

Steam Turbine and Governor

accordingly. In any case, inertias must be consistent with torque fractions. You cannot set an inertia to 0 and set the corresponding torque fraction to a nonzero value. However, you can set a torque fraction to 0 and set the corresponding mass inertia to a nonzero value.

Initial power and generator rotor angle

If the shaft is multimass, enter the initial mechanical power P_{m0} (p.u.) and initial generator angle θ_{e0} (degrees). If the shaft is single mass, enter only initial mechanical power.

Initial mechanical power is automatically updated by the load flow utility of the Powergui block. Initial angle is also computed by the load flow utility and is written in the associated Synchronous Machine block dialog box.

Inputs and Outputs

wref

The speed reference, in p.u. It is normally connected to a Constant block with the value set to 1.0 p.u.

Pref

The electrical power reference, in p.u. It is set to a constant value corresponding to the initial active power drawn from the Synchronous Machine block connected to the Steam Turbine and Governor block.

wm

The generator's speed, in p.u. This is one of the signals in the last output of the Synchronous Machine model (internal variables).

d_theta

The generator's power angle deviation. It is also one of the signals in the last output of the Synchronous Machine model (internal variables).

dw_5-2

Output a vector containing the speed deviations, in p.u., of masses 5, 4, 3, and 2.

Tr5-2

Output a vector containing the torques, in p.u., transmitted by masses 5, 4, 3, and 2.

gate

Gate opening in p.u.

Pm

The mechanical power, in p.u., that you connect to the first input of a Synchronous Machine block.

Example

The `power_thermal` demo illustrates the use of the Steam Turbine and Governor block. This system is an IEEE benchmark used to study subsynchronous resonance and particularly torque amplification after a fault on a series-compensated power system [2]. It consists in a single generator connected to an infinite bus via two transmission lines, one of which is series compensated. The subsynchronous mode introduced by the compensation capacitor after a fault has been applied and cleared excites the oscillatory torsional modes of the multimass shaft and the torque amplification phenomenon can be observed. Open the Simulink diagram by typing `power_thermal`.

This system is slightly different from the one presented in [2]. Since we are using the Synchronous Machine mass as the first mass, we cannot model the exciter's mass as is done in [2]. Therefore, our system has only three masses, representing the generator's rotor (mass #1) and the turbine's low and high pressure stages (masses #2 and #3, respectively).

Steam Turbine and Governor

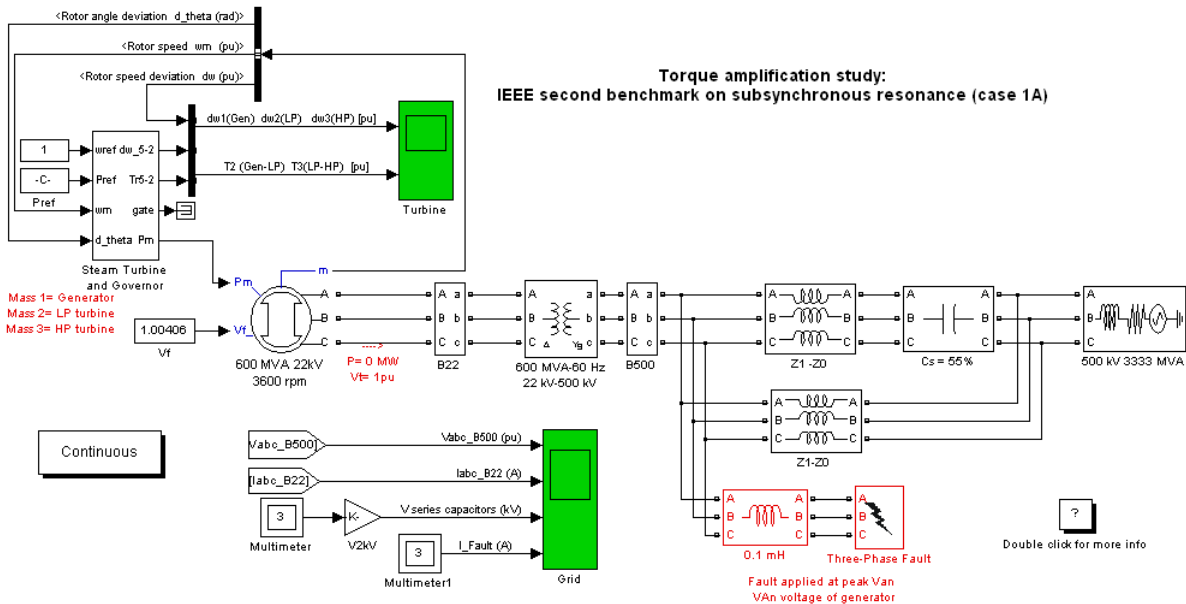

In order to start the simulation in steady state, you must first initialize the synchronous machine and steam turbine by using the **Load Flow and Machine Initialization** utility of the Powergui. Set the generator as a PV generator with zero active power to simulate an initially unloaded generator.

This test is performed without regulators. The machine's excitation voltage is also set to a constant value (1.00406 p.u.), which is computed by the load flow.

Run the simulation. Once the simulation is completed, observe the mass speed deviations, torques, series capacitor voltages and fault currents.

Steam Turbine and Governor

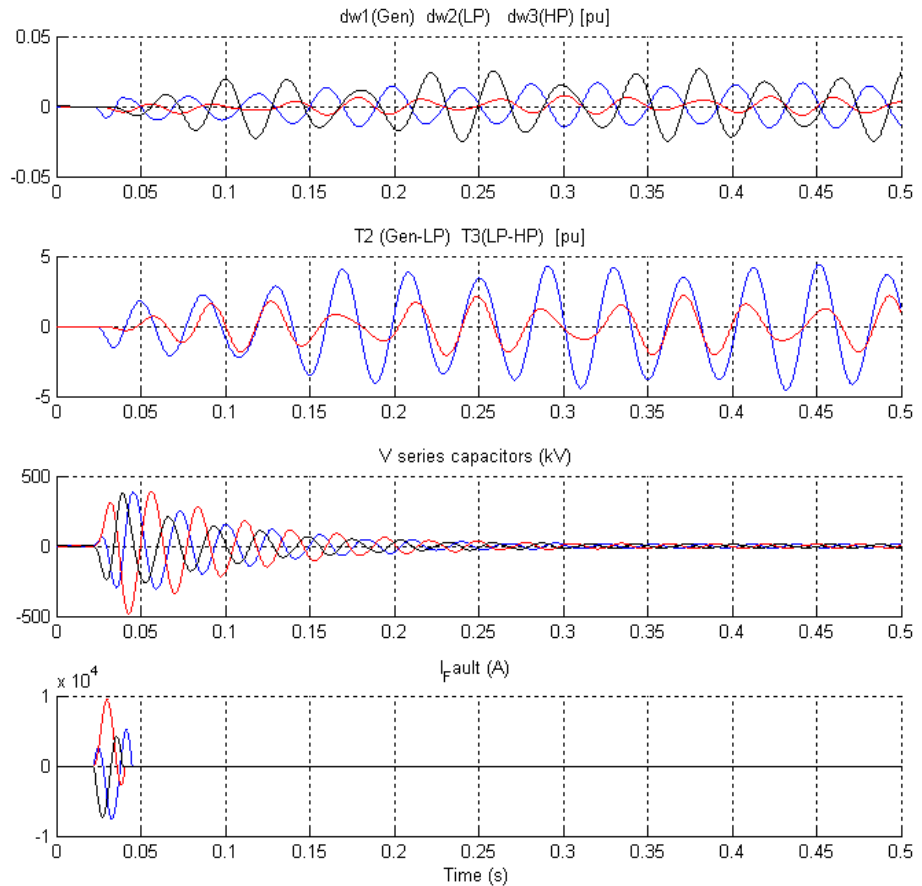

The peak values of all these signals correspond within 3% to those given in Table 5, case 1A, of [2]. The torque amplification is clearly observed on all masses of the shaft system. The high-pressure turbine (mass #3) transmits a peak torque exceeding 2 p.u. to the low-pressure turbine (mass #2), while the low-pressure turbine transmits a peak torque exceeding 4 p.u. to the generator's rotor (mass #1).

Steam Turbine and Governor

References

[1] IEEE committee report, "Dynamic models for steam and hydro turbines in power system studies," *IEEE Transactions on Power Apparatus and Systems*, Vol. PAS-92, No. 6, 1973, pp. 1904-1915.

[2] IEEE Subsynchronous resonance working group, "Second benchmark model for computer simulation of subsynchronous resonance," *IEEE Transactions on Power Apparatus and Systems*, Vol. PAS-104, No. 5, 1985, pp. 1057-1066.

See Also

Excitation System, Hydraulic Turbine and Governor, Powergui, Synchronous Machine

Purpose Implement a metal-oxide surge arrester

Library Elements

Description



The Surge Arrester block implements a highly nonlinear resistor used to protect power equipment against overvoltages. For applications requiring high power dissipation, several columns of metal-oxide discs are connected in parallel inside the same porcelain housing. The nonlinear V-I characteristic of each column of the surge arrester is modeled by a combination of three exponential functions of the form

$$\frac{V}{V_{ref}} = k_i \left(\frac{I}{I_{ref}} \right)^{1/\alpha_i}$$

The protection voltage obtained with a single column is specified at a reference current (usually 500 A or 1 kA). Default parameters k and α given in the dialog box fit the average V-I characteristic provided by the main metal-oxide arrester manufacturers and they do not change with the protection voltage. The required protection voltage is obtained by adding discs of zinc oxide in series in each column.

This V-I characteristic is graphically represented as follows (on a linear scale and on a logarithmic scale).

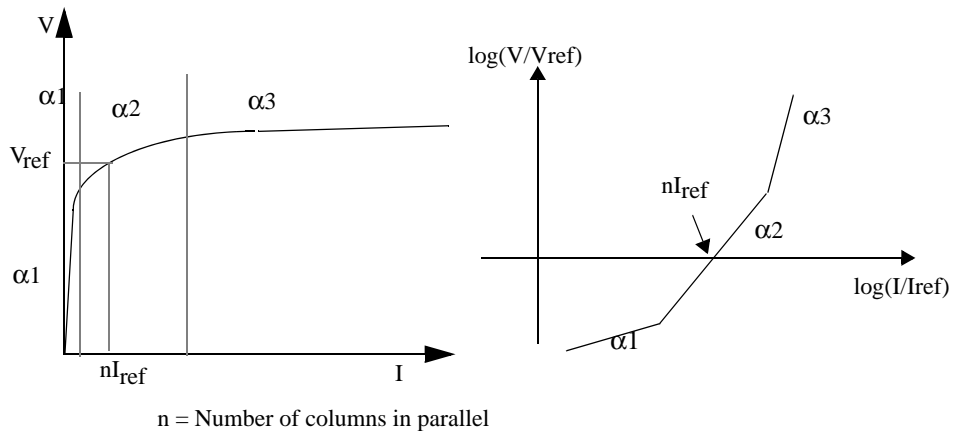

Surge Arrester

Dialog Box and Parameters

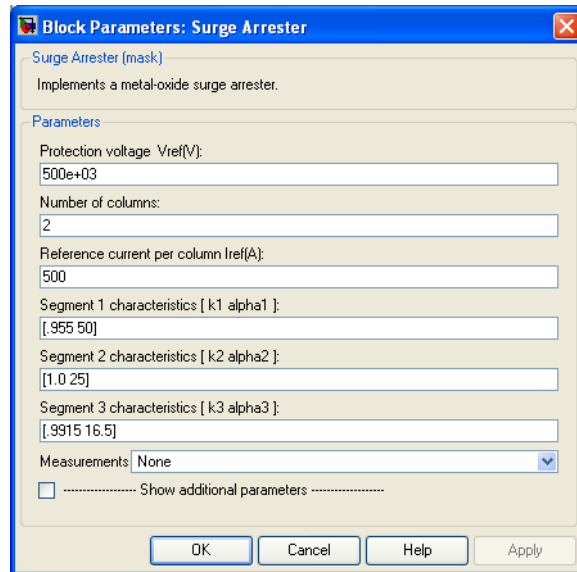

Protection voltage V_{ref}

The protection voltage of the Surge Arrester block, in volts (V).

Number of columns

The number of metal-oxide disc columns. The minimum is one.

Reference current per column I_{ref}

The reference current of one column used to specify the protection voltage, in amperes (A).

Segment 1 characteristics

The k and α parameters of segment 1.

Segment 2 characteristics

The k and α parameters of segment 2.

Segment 3 characteristics

The k and α characteristics of segment 3.

Measurements

Select **Branch voltage** to measure the voltage across the Surge Arrester block terminals.

Select **Branch current** to measure the current flowing through the Surge Arrester block.

Select **Branch voltage** and **current** to measure the surge arrester voltage and current.

Place a Multimeter block in your model to display the selected measurements during the simulation. In the **Available Measurements** list box of the Multimeter block, the measurement is identified by a label followed by the block name.

Measurement	Label
Branch voltage	Ub:
Branch current	Ib:

Limitations

The Surge Arrester block is modeled as a current source driven by the voltage appearing across its terminals. Therefore, it cannot be connected in series with an inductor or another current source. As the Surge Arrester block is highly nonlinear, a stiff integrator algorithm must be used to simulate the circuit. Ode23t with default parameters usually gives the best simulation speed. For continuous simulation, in order to avoid an algebraic loop, the voltage applied to the nonlinear resistance is filtered by a first-order filter with a time constant of 0.01 microseconds. This very fast time constant does not significantly affect the result accuracy.

When you use the Surge Arrester block in a discrete system, you will get an algebraic loop. This algebraic loop, which is required in most cases to get an accurate solution, tends to slow down the simulation. However, to speed up the simulation, in some circumstances, you can disable the algebraic loop by checking **Show additional parameters** and then **Break algebraic loop in discrete model**. You should be aware that disabling the algebraic loop introduces a one simulation step time delay in the model. This can cause numerical oscillations if the sample time is too large.

Surge Arrester

Example

The power_arrester demo illustrates the use of metal-oxide varistors (MOV) on a 735 kV series-compensated network. Only one phase of the network is represented. The capacitor connected in series with the line is protected by a 30 column arrester. At $t = 0.03$ seconds, a fault is applied at the load terminals. The current increases in the series capacitor and produces an overvoltage that is limited by the Surge Arrester block. Then the fault is cleared at $t = 0.1$ seconds.

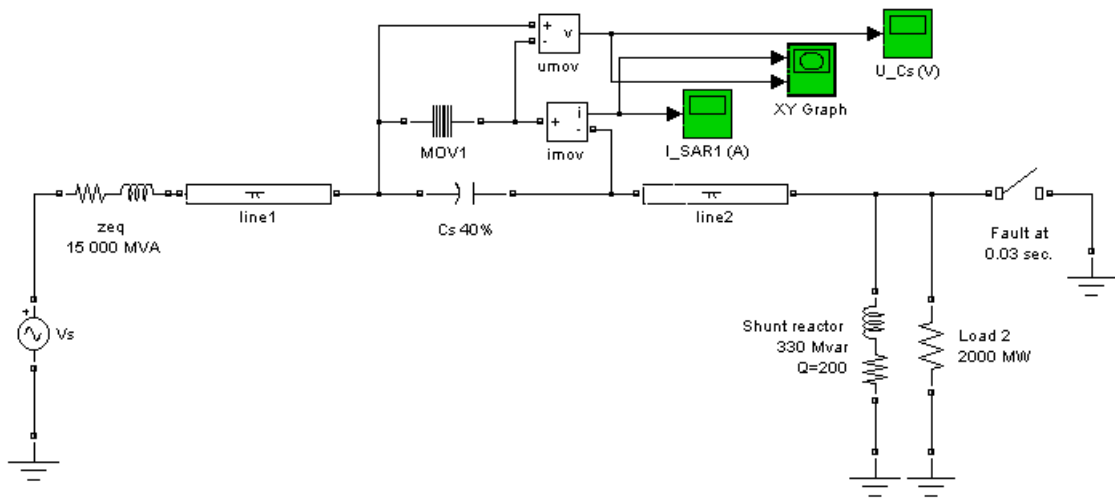

At fault application, the resulting overvoltage makes the MOV conduct. The waveforms displayed by U_{mov} and I_{mov} measurements as well as the V-I characteristic plotted by the X-Y scope are shown below:

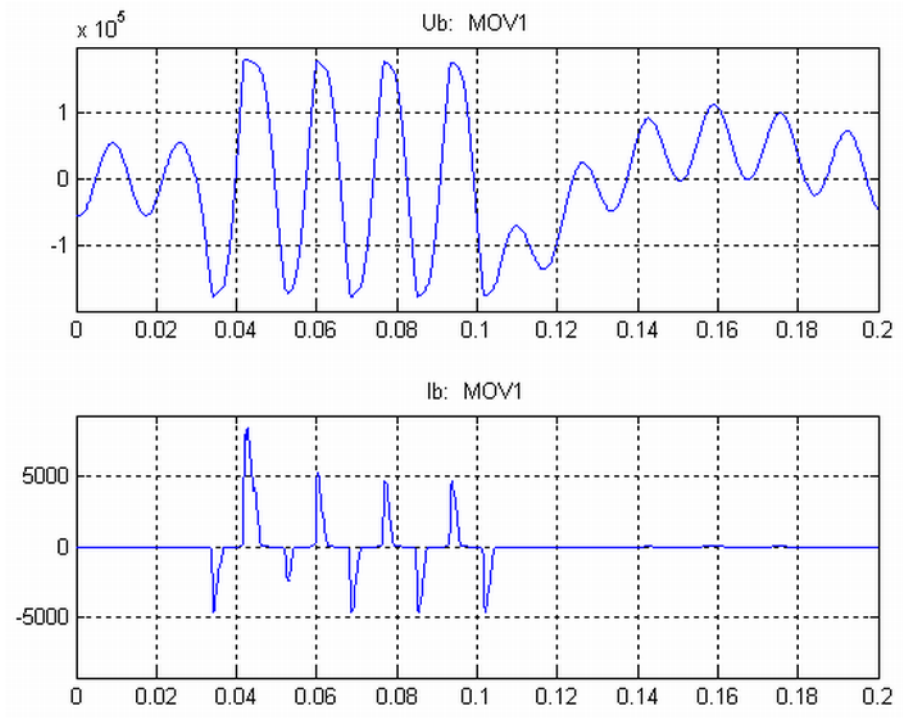

Surge Arrester

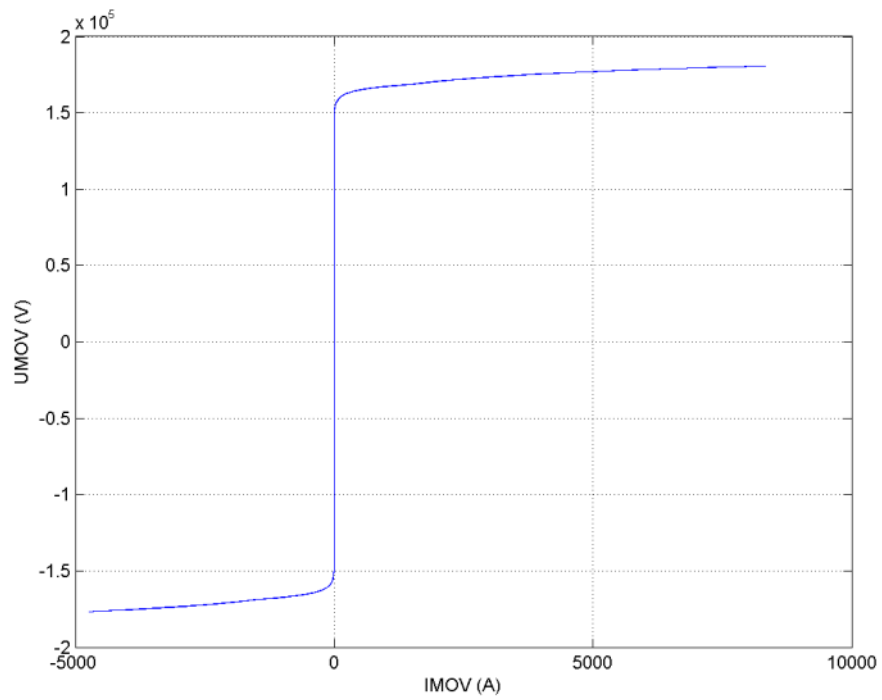

See Also

Multimeter

Purpose

Model the dynamics of a switched reluctance motor

Library

Machines

Description

The Switched Reluctance Motor (SRM) block represents three most common switched reluctance motors: three-phase 6/4 SRM, four-phase 8/6 SRM, five-phase 10/8 SRM, as shown in the following figure.

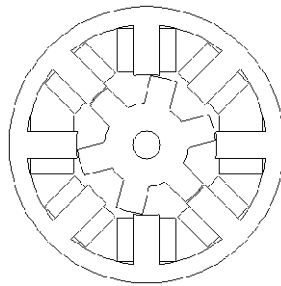
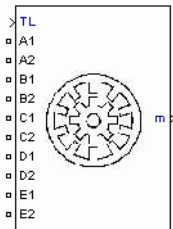
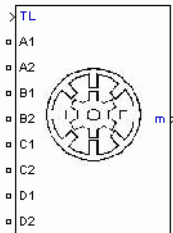
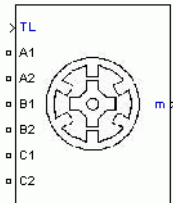

Three-phase 6/4 SRM

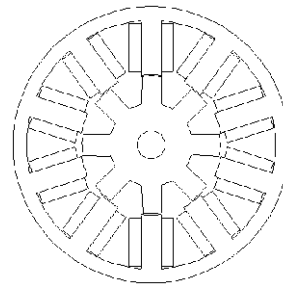

Four-phase 8/6 SRM

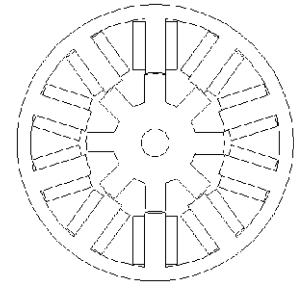

Five-phase 10/8 SRM

The electric part of the motor is represented by a nonlinear model based on the magnetization characteristic composed of several magnetizing curves and on the torque characteristic computed from the magnetization curves. The mechanic part is represented by a state-space model based on inertia moment and viscous friction coefficient.

To be versatile, two models are implemented for the SRM block: specific and generic models. In the specific SRM model, the magnetization characteristic of the motor is provided in a lookup table. The values are obtained by experimental measurement or calculated by finite-element analysis. In the generic model, the magnetization characteristic is calculated using nonlinear functions and readily available parameters.

Switched Reluctance Motor

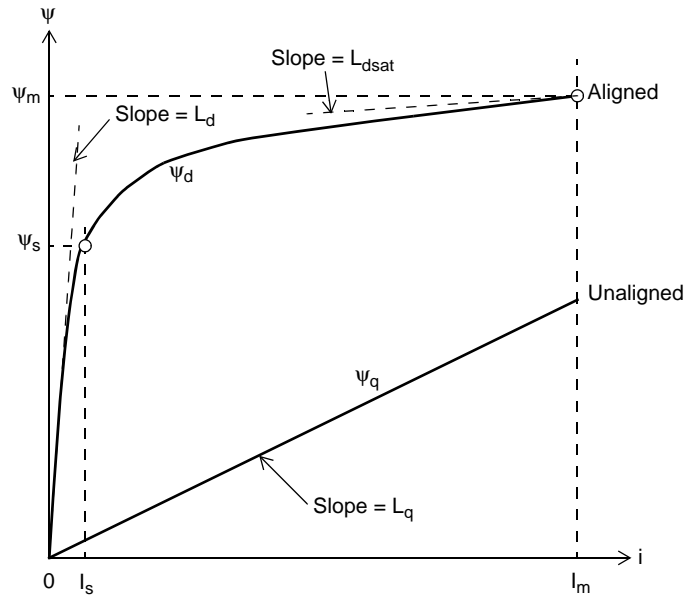

Dialog Box and Parameters

You can choose between specific model and generic model:

Specific model

Block Parameters: Switched Reluctance Motor

Switched Reluctance Motor (mask) (link)

Depending on the motor configuration specified by the Type parameter, this block models:

- a three-phase Switched Reluctance Motor having 6 stator poles and 4 rotor poles.
- a four-phase Switched Reluctance Motor having 8 stator poles and 6 rotor poles.
- a five-phase Switched Reluctance Motor having 10 stator poles and 8 rotor poles.

You can use a generic model or a specific model:

The generic model is characterized by the aligned and unaligned inductances, the saturated aligned inductance, the maximum current, and the maximum flux linkage.

The specific model is characterized by the magnetization characteristic given as a table of flux linkage in function of the rotor position and the stator current.

Parameters

Type: 6/4

Machine model: Specific model

Plot magnetization curves

Stator resistance (Ohm): 0.01

Inertia (kg.m.m): 0.0082

Friction (N.m.s): 0.01

Initial speed and position [wo (rad/s) Theta0 (rad)]: [0 0]

Magnetisation characteristic table (MAT file): 'srm64_60kw.mat'

Rotor angle vector used in MAT file (degrees): [0 10 20 30 40 45]

Stator current vector used in MAT file (A): 0.25:450

OK Cancel Help Apply

Plot magnetization curves

If selected, the mask plots the magnetization curves corresponding to the lookup table provided. The magnetization curves represent the machine flux linkage versus the stator current with the rotor position as a parameter.

Stator resistance

The resistance R_s (Ω) of each stator phase winding.

Switched Reluctance Motor

Inertia

The inertia momentum J ($\text{kg}\cdot\text{m}^2$)

Friction

The friction coefficient B ($\text{N}\cdot\text{m}\cdot\text{s}$)

Initial speed

The initial rotation speed N_0 (rpm)

Rotor angle vector

The rotor position θ (deg) for which the flux linkage is specified.

Stator current vector

The stator current I_s (A) for which the flux linkage is specified.

Magnetization characteristic

The 2-D lookup table containing the flux linkage as a function of stator current and rotor position.

Generic model

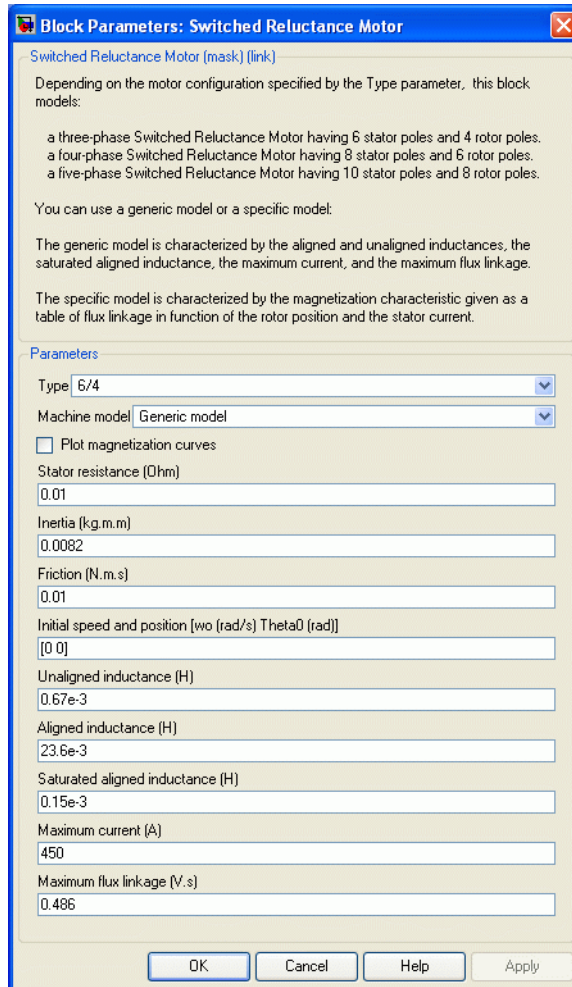

Block Parameters: Switched Reluctance Motor

Switched Reluctance Motor [mask] [link]

Depending on the motor configuration specified by the Type parameter, this block models:

- a three-phase Switched Reluctance Motor having 6 stator poles and 4 rotor poles.
- a four-phase Switched Reluctance Motor having 8 stator poles and 6 rotor poles.
- a five-phase Switched Reluctance Motor having 10 stator poles and 8 rotor poles.

You can use a generic model or a specific model.

The generic model is characterized by the aligned and unaligned inductances, the saturated aligned inductance, the maximum current, and the maximum flux linkage.

The specific model is characterized by the magnetization characteristic given as a table of flux linkage in function of the rotor position and the stator current.

Parameters

Type: 6/4

Machine model: Generic model

Plot magnetization curves

Stator resistance (Ohm): 0.01

Inertia (kg.m.m): 0.0082

Friction (N.m.s): 0.01

Initial speed and position [ω_0 (rad/s) θ_0 (rad)]: [0 0]

Unaligned inductance (H): 0.67e-3

Aligned inductance (H): 23.6e-3

Saturated aligned inductance (H): 0.15e-3

Maximum current (A): 450

Maximum flux linkage (V.s): 0.486

OK Cancel Help Apply

Plot magnetization curves

If selected, the mask plots the magnetization curves corresponding to the parameters provided. The magnetization curves represent the machine flux linkage versus the stator current with the rotor position as a parameter.

Switched Reluctance Motor

Stator resistance

The resistance R_s (Ω) of each stator phase winding.

Inertia

The inertia momentum J (kg.m^2)

Friction

The friction coefficient B (N.m.s)

Initial speed

The initial rotation speed N_0 (rpm)

Unaligned inductance

The stator inductance when the rotor is in unaligned position L_q (H).

Aligned inductance

The unsaturated stator inductance when the rotor is in aligned position L_d (H).

Saturated aligned inductance

The saturated stator inductance when the rotor is in aligned position L_{dsat} (H).

Maximum current

The stator maximum current I_m (A).

Maximum flux linkage

The maximum flux linkage ψ_m (Wb or V.s) corresponding to I_m .

Inputs and Outputs

The Simulink input T_L is the mechanical load torque (In N.m). T_L is positive in motor mode and negative in generation mode.

The block output m is a vector containing several signals. You can demultiplex these signals by using the Bus Selector block of Simulink.

Signal	Definition	Units
V	Stator voltages	V
flux	Flux linkage	V.s
I	Stator currents	A

Switched Reluctance Motor

Te	Electromagnetic torque	N.m
w	Rotor speed	rad/s
teta	Rotor position	rad

Example

The power_SwitchedReluctanceMotor demo illustrate the simulation of the Switch Reluctance Motor

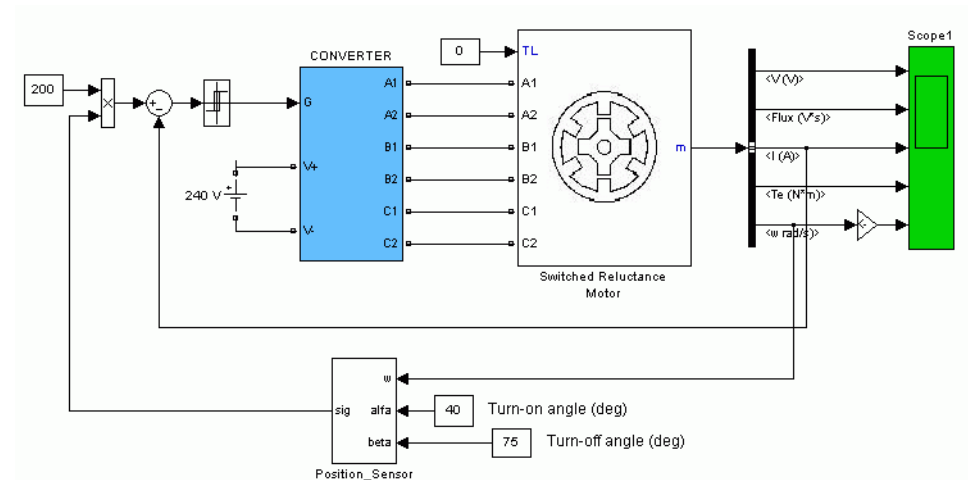

References

- T.J.E. Miller, *Switched Reluctance Motors and Their Control*, Clarendon Press, Oxford, 1993.
- R. Krishnan, *Switched Reluctance Motor Drives*, CRC Press, 2001.
- D.A. Torrey, X.M. Niu, E.J. Unkauf, "Analytical modelling of variable-reluctance machine magnetisation characteristics", *IEE Proceedings - Electric Power Applications*, Vol. 142, No. 1, January 1995, pp. 14-22.
- H. Le-Huy, P. Brunelle, "Design and Implementation of a Switched Reluctance Motor Generic Model for Simulink SimPowerSystems", *Electrimacs2005 Conference*.

Synchronized 6-Pulse Generator

Purpose Implement a synchronized pulse generator to fire the thyristors of a six-pulse converter

Library Extras/Control Block
A discrete version of this block is available in the Extras/Discrete Control Blocks library.

Description The Synchronized 6-Pulse Generator block can be used to fire the six thyristors of a six-pulse converter. The output of the block is a vector of six pulses individually synchronized on the six thyristor voltages. The pulses are generated alpha degrees after the increasing zero crossings of the thyristor commutation voltages.

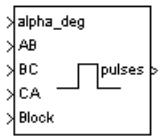

The figures below display the synchronization of the six pulses for an alpha angle of 0 degrees. The pulses are generated exactly at the zero crossings of the three line-to-line synchronization voltages.

Synchronized 6-Pulse Generator

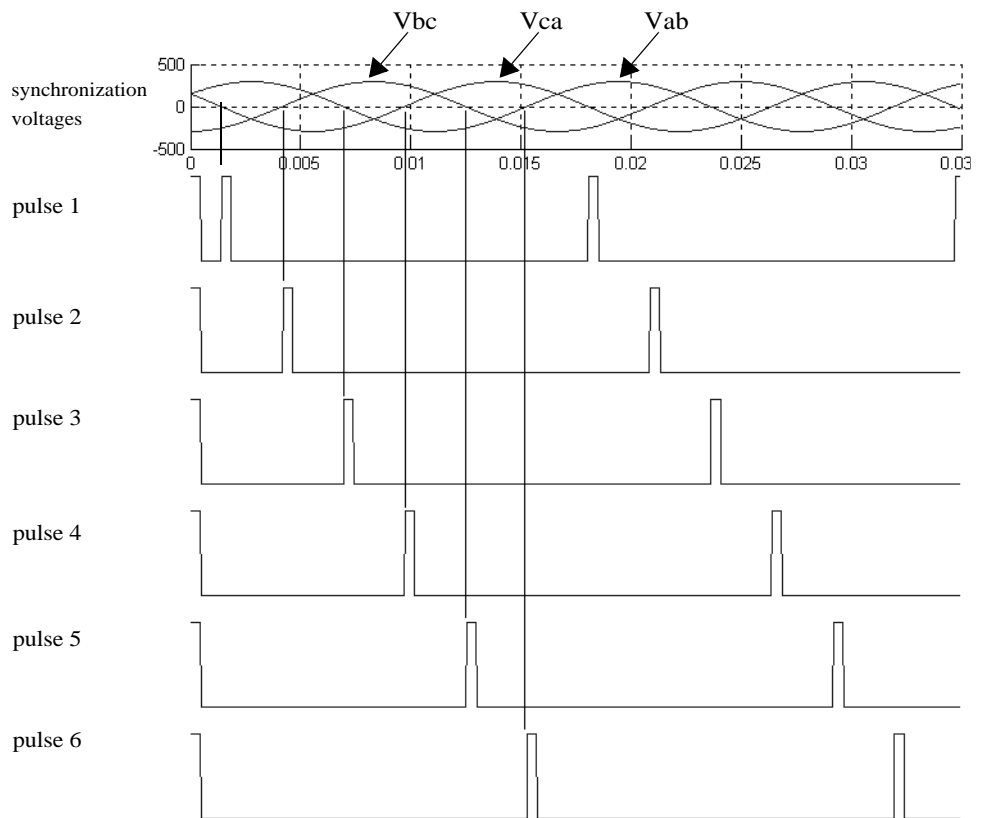

The Synchronized 6-Pulse Generator block can be configured to work in double-pulsing mode. In this mode two pulses are sent to each thyristor: a first pulse when the alpha angle is reached, then a second pulse 60 degrees later, when the next thyristor is fired.

Synchronized 6-Pulse Generator

The figures below display the synchronization of the six pulses for an alpha angle of 30 degrees and with double-pulsing mode. Notice that the pulses are generated 30 degrees after the zero crossings of the line-to-line.

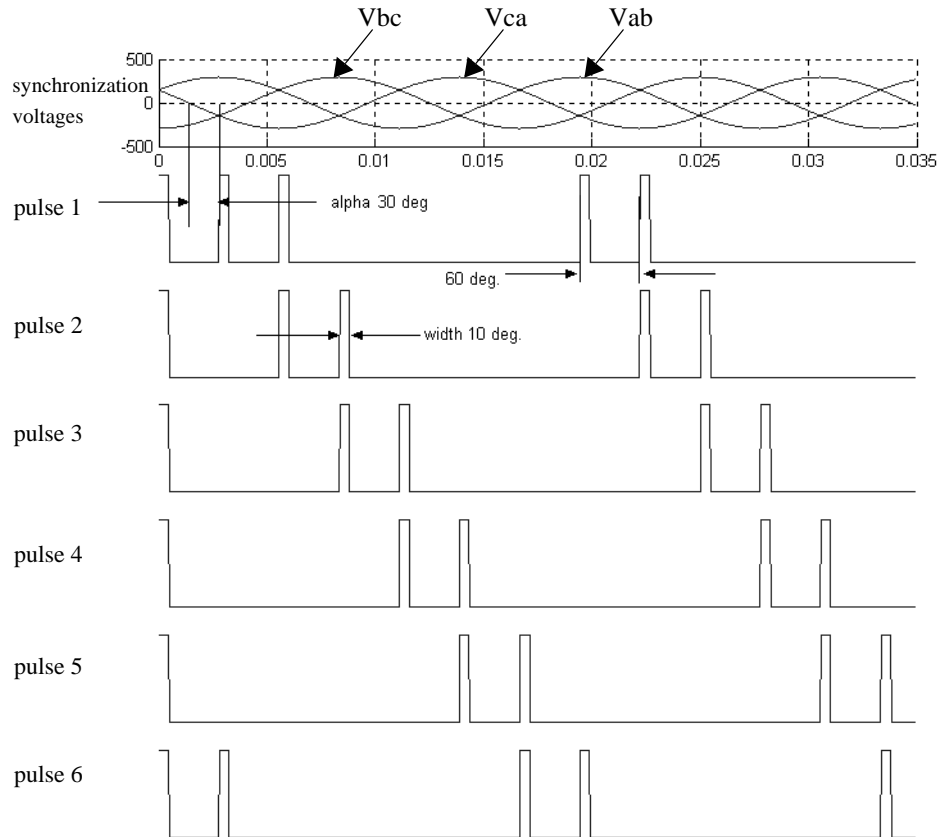

The pulse ordering at the output of the block corresponds to the natural order of commutation of a three-phase thyristor bridge. When you connect the Synchronized 6-Pulse Generator block to the pulses input of the Universal Bridge block (with the thyristors as the power electronic device), the pulses are sent to the thyristors in the following order:

Synchronized 6-Pulse Generator

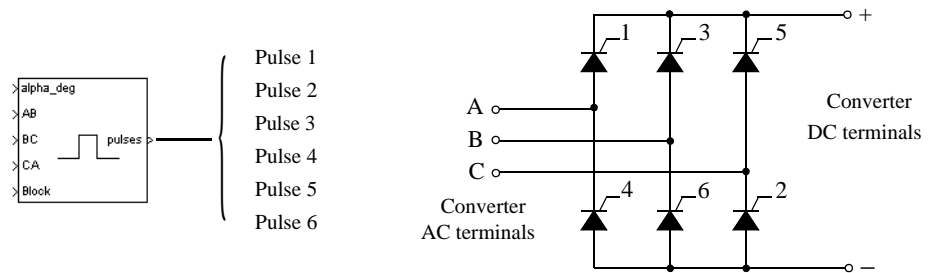

When you build your own three-phase thyristor bridge with single thyristor blocks, you need to connect the pulse signals of the Synchronized 6-Pulse Generator block to the gate inputs of the corresponding thyristors.

Dialog Box and Parameters

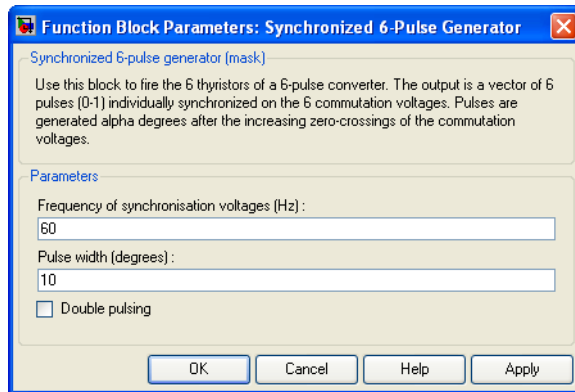

Frequency of synchronization voltages

The frequency, in hertz, of the synchronization voltages. It usually corresponds to the frequency of the network.

Pulse width

The width of the pulses, in degrees.

Synchronized 6-Pulse Generator

Double pulsing

If selected, the generator sends to each thyristor a first pulse when the alpha angle is reached, and then a second pulse 60 degrees later when the next thyristor in the sequence is fired.

Inputs and Outputs

alpha_deg

Input 1 is the alpha firing signal, in degrees. This input can be connected to a Constant block, or it can be connected to a controller system to control the pulses of the generator.

AB, BC, CA

Inputs 2, 3, and 4 are the phase-to-phase synchronization voltages V_{ab} , V_{bc} , and V_{ca} . The synchronization voltages should be in phase with the three phase-phase voltages at the converter AC terminals. Synchronization voltages are normally derived at the primary windings of the converter transformer. If the converter is connected to the delta winding of a Wye/Delta transformer, the synchronization voltages should be the phase-to-ground voltages of the primary windings.

Freq

Available only with the discrete version of the Synchronized 6-Pulse Generator. This input should be connected to a constant block containing the fundamental frequency, in hertz, or to a PLL tracking the frequency of the system.

block

Input 5 allows you to block the operation of the generator. The pulses are disabled when the applied signal is greater than zero.

pulses

The output contains the six pulse signals.

Synchronized 6-Pulse Generator

Example

The power_sixpulses demo uses a Synchronized 6-Pulse Generator block to fire the thyristors of a six-pulse thyristor bridge. The bridge is fed by a three-phase voltage source (200 V peak line-to-ground or 245 V RMS line-to-line) and it is connected to a resistive load.

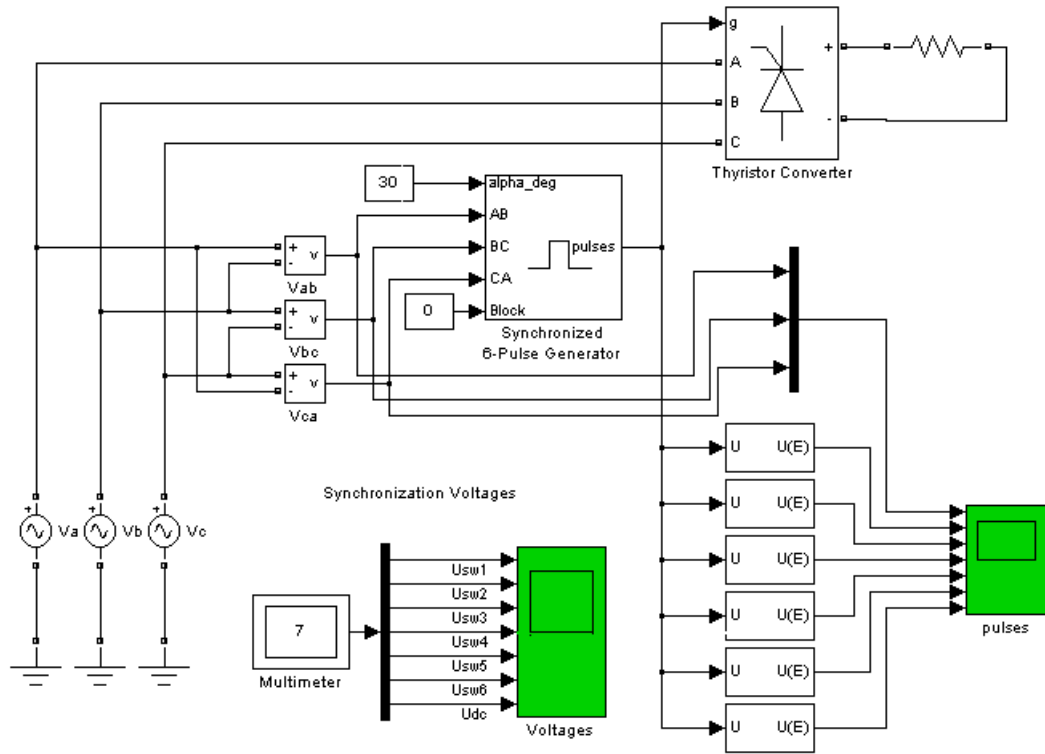

A first simulation is performed with an alpha angle of 0 degrees. Open the Constant block connected at input 1 of the Synchronized 6-Pulse Generator block and set its value to 0. Start the simulation. The average voltage is

$$V_{dc} = \frac{3\sqrt{2}}{\pi} E = \frac{3\sqrt{2}}{\pi} 245 = 331 \text{ volts}$$

Synchronized 6-Pulse Generator

The six thyristor voltages are displayed in the next figure. The resulting DC voltage at the output of the rectifier is also displayed (average value of 331 V).

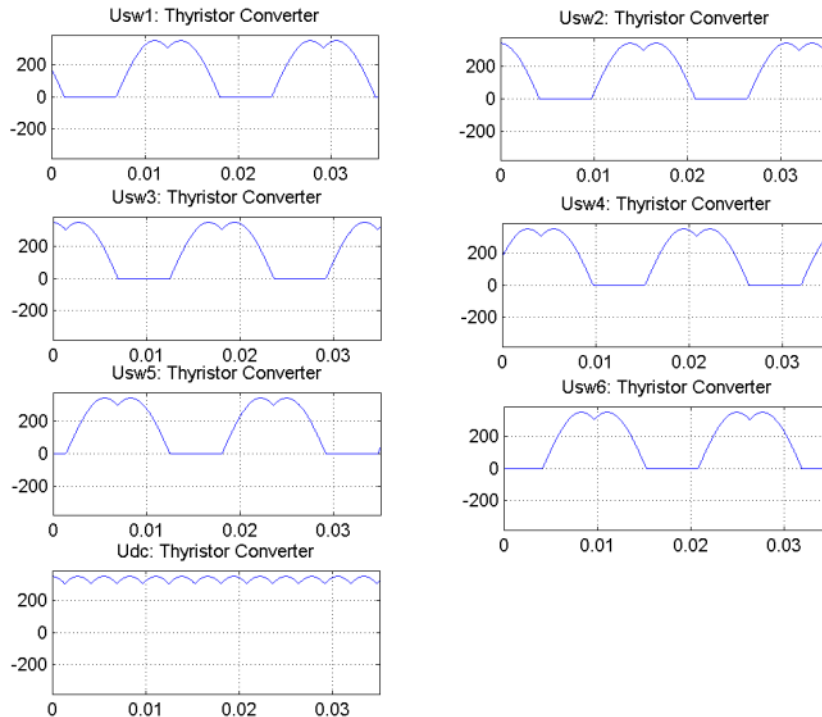

Now change the value of the alpha angle to 30 degrees and start the simulation. Notice that the waveforms of the thyristor voltages look different from the previous case. The thyristors start conducting 30 degrees after their commutation voltage becomes positive and the resulting DC voltage at the output of the rectifier is lower. Its average value is now

$$V_{dc} = \frac{3\sqrt{2}}{\pi} E \cos(\alpha) = \frac{3\sqrt{2}}{\pi} 245 \cos(30^\circ) = 286 \text{ volts}$$

Synchronized 6-Pulse Generator

The thyristor voltages and DC voltage for $\alpha = 30$ degrees are

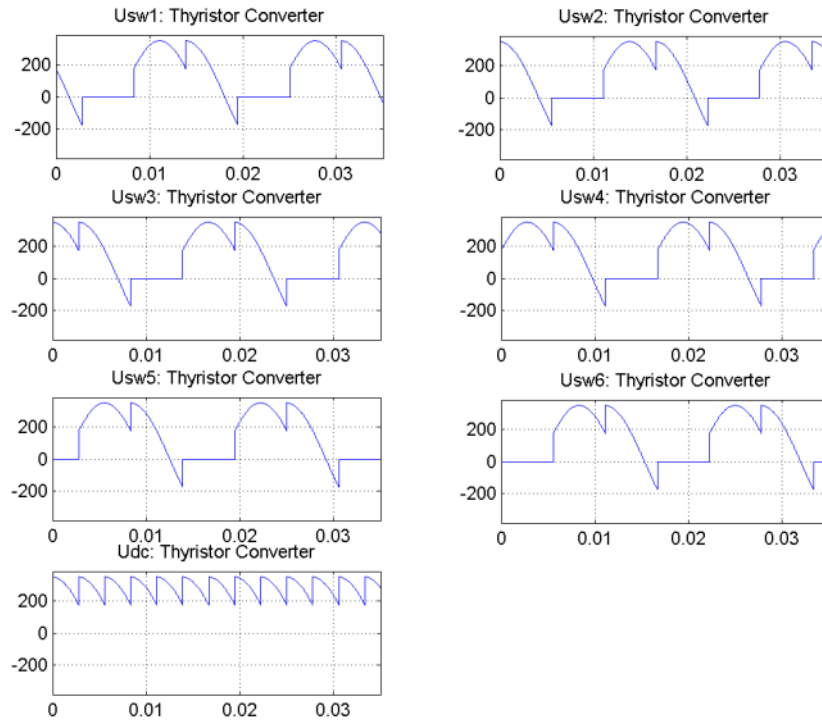

The figures show that the mean value of the DC voltage can be controlled by the alpha angle applied to the Synchronized 6-Pulse Generator block.

See Also

The `power_hvdc` demo illustrates the use of the Discrete Synchronized 6-Pulse Generator block.

Synchronized 12-Pulse Generator

Synchronized 12-Pulse Generator

Purpose

Implement a synchronized pulse generator to fire the thyristors of a twelve-pulse converter

Library

Extras/Control Blocks

A discrete version of this block is available in the Extras/Discrete Control Blocks library.

Description

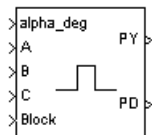

The Synchronized 12-Pulse Generator block generates two vectors of six pulses synchronized on the twelve thyristor commutation voltages. The first set of pulses, denoted PY, is sent to the six-pulse bridge connected to the wye secondary winding of the Y/Y/Delta converter transformer. It is generated alpha degrees after the zero crossing of the phase-to-phase synchronization voltages. The second set of pulses, denoted PD, is sent to the six-pulse bridge connected to the delta secondary winding of the converter transformer. It lags the PY pulses by 30 degrees.

The figure below shows the three synchronization voltages and the first three pulses of the two output vectors. The synchronization voltages are the three phase-to-ground voltages V_a , V_b , V_c measured on the primary side (Y) of the Y/Y/Delta converter transformer.

Synchronized 12-Pulse Generator

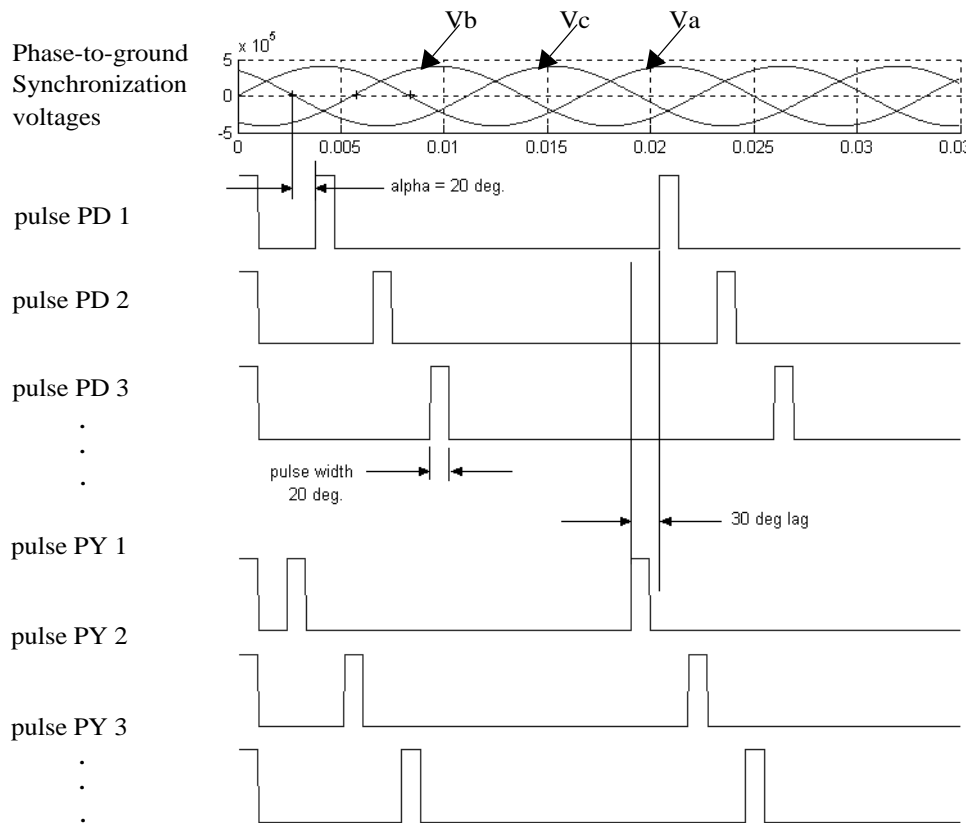

The phase-to-ground A,B, and C voltages are provided to the generator, and the two sets of phase-to-phase synchronization voltages required by the two six-pulse bridges are generated internally.

Synchronized 12-Pulse Generator

The ordering of the pulses in the two outputs of the block corresponds to the natural order of commutation of a three-phase thyristor bridge. When you connect the Synchronized 12-Pulse Generator block outputs to the pulse inputs of the Universal Bridge blocks (with the thyristor device), the pulses are sent to the thyristors in the following way:

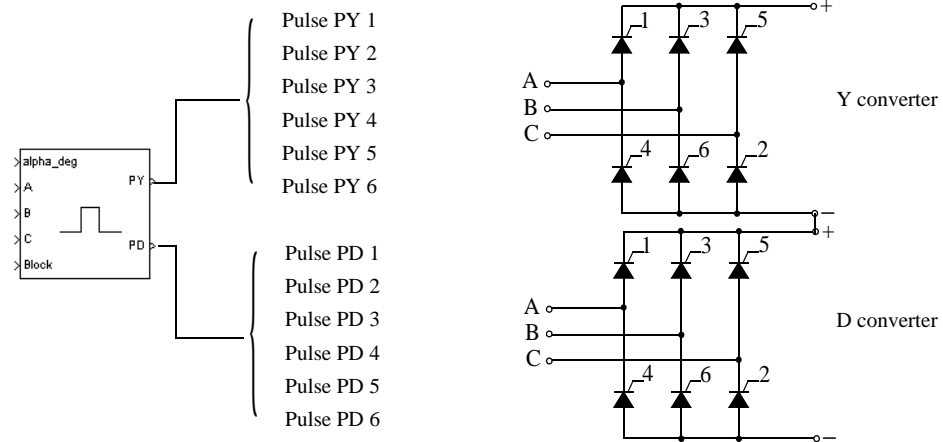

Synchronized 12-Pulse Generator

Dialog Box and Parameters

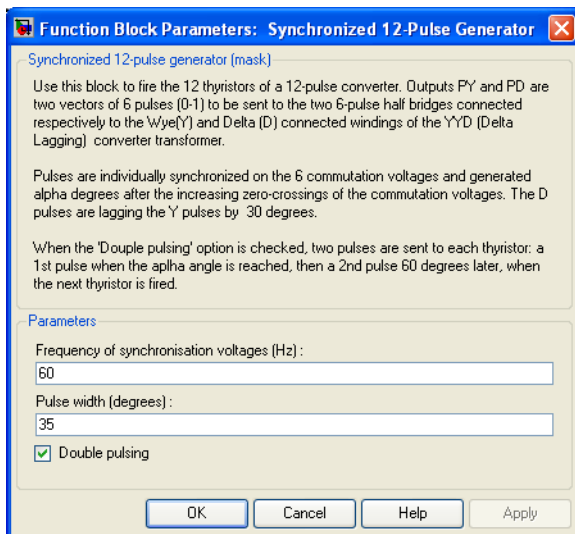

Frequency of synchronization voltages

The frequency, in hertz, of the synchronization voltages. It usually corresponds to the frequency of the network.

Pulse width

The width of the pulses, in degrees.

Double pulsing

If selected, the generator sends to each thyristor a first pulse when the alpha angle is reached, and then a second pulse 60 degrees later when the next thyristor in the sequence is fired. The double pulsing is applied separately on the two vectors of pulses.

Inputs and Outputs

alpha_deg

Input 1 is the alpha firing signal, in degrees. This input can be connected to a Constant block, or it can be connected to a controller system to control the pulses of the generator.

A, B, C

Synchronized 12-Pulse Generator

Inputs 2, 3, and 4 are the phase-to-ground synchronization voltages V_a , V_b , and V_c . The synchronization voltages should be measured at the primary side of the converter transformer.

Freq

Available only with the discrete version of the Synchronized 6-Pulse Generator. This input should be connected to a constant block containing the fundamental frequency, in hertz, or to a PLL tracking the frequency of the system.

block

Input 5 allows you to block the operation of the generator. The pulses are disabled when the applied signal is greater than zero.

PY

Output 1 contains the six-pulse signals to be sent to the six-pulse thyristor converter connected to the Y secondary winding of the converter transformer.

PD

Output 2 contains the six-pulse signals to be sent to the six-pulse thyristor converter connected to the Delta (D) secondary winding of the converter transformer.

Example

In the `power_twelvepulses` demo a Synchronized 12-Pulse Generator block is used to fire the thyristors of a twelve-pulse thyristor bridge built with two six-pulse bridges. The bridge is fed by a three-winding three-phase transformer (500 kV / 200 kV / 200 kV). The Y-connected secondary feeds the first six-pulse bridge. The Delta secondary feeds the second bridge. The transformer is assumed to be ideal (no leakage reactances, no resistance). The expected DC voltage obtained for $\alpha = 0$ is

$$V_{dc} = 2 \frac{3\sqrt{2}}{\pi} 200 \text{ kV} = 540 \text{ kV}$$

The two bridge rectifiers are connected in series and a 300 km DC line is connected to the rectifier.

Synchronized 12-Pulse Generator

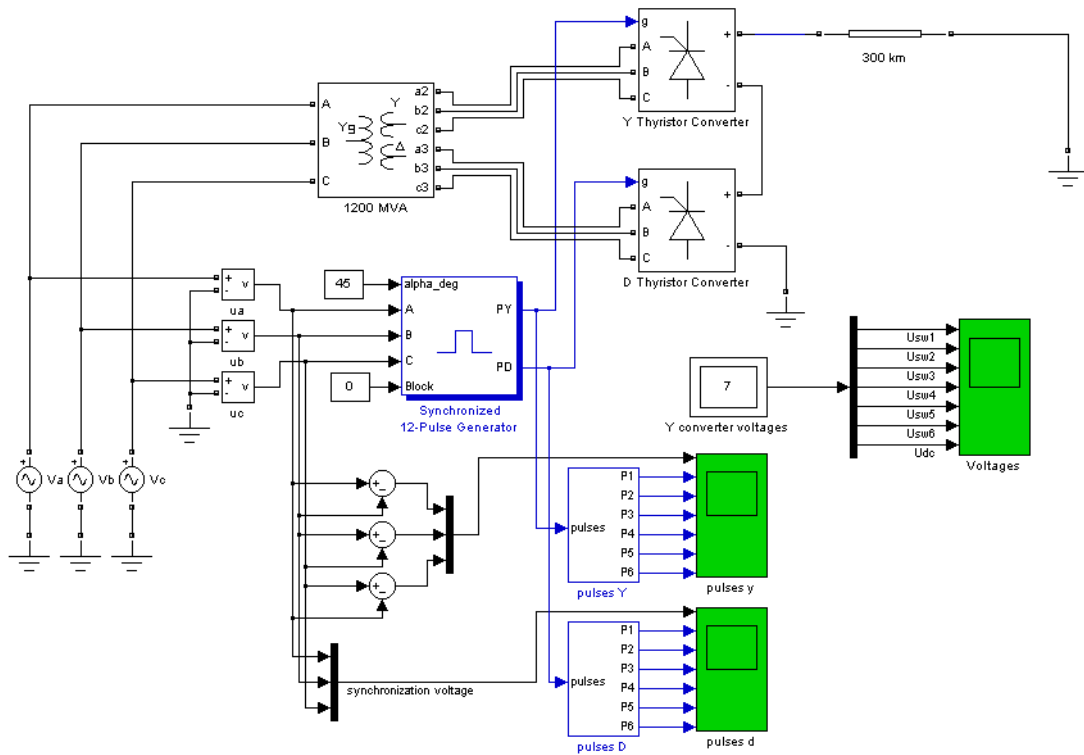

Synchronized 12-Pulse Generator

A first simulation is performed with an alpha angle of 0 degrees. Open the Constant block connected at input 1 of the Synchronized 12-Pulse Generator block and set its value to 0. Start the simulation. The voltages of the thyristors of the D thyristor Converter block are displayed in the next figure. The resulting DC voltage at the input terminal of the transmission line is also displayed (average value = 540 kV).

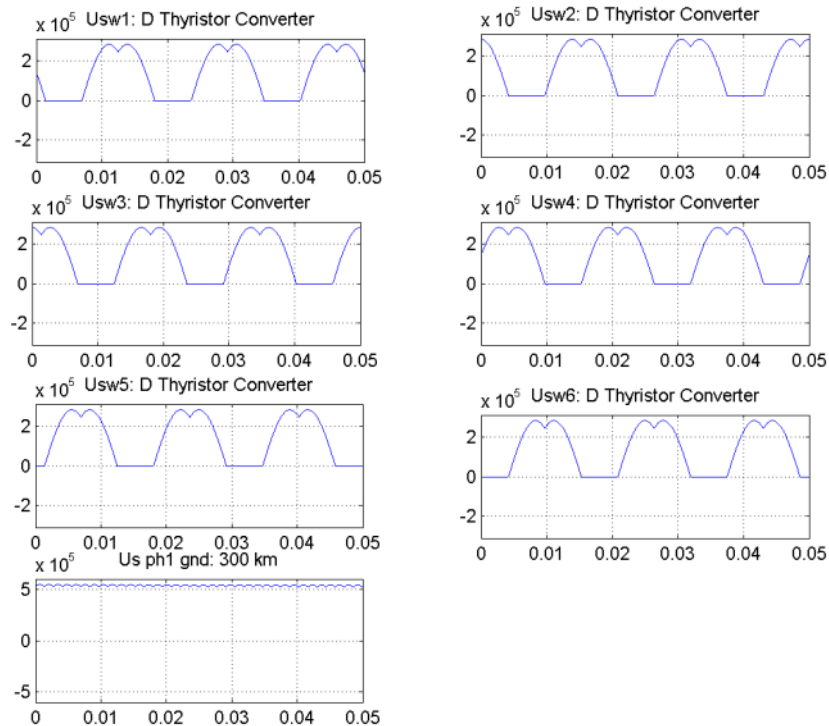

Compare the DC voltage generated by the Synchronized 12-Pulse Generator with the DC voltage you obtained with the Synchronized 6-Pulse Generator. Notice that the ripple in the DC voltage waveform is lower. The rectifier voltage contains the harmonics $12 \cdot k$ ($k = 1, 2, \dots$).

See Also

The power_hvdc12pulse demo illustrates the use of the Discrete Synchronized 12-Pulse Generator block.

Synchronized 6-Pulse Generator

Purpose

Model the dynamics of a three-phase round-rotor or salient-pole synchronous machine

Library

Machines

Description

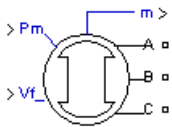

The Synchronous Machine block operates in generator or motor modes. The operating mode is dictated by the sign of the mechanical power (positive for generator mode, negative for motor mode). The electrical part of the machine is represented by a sixth-order state-space model and the mechanical part is the same as in the Simplified Synchronous Machine block.

The model takes into account the dynamics of the stator, field, and damper windings. The equivalent circuit of the model is represented in the rotor reference frame (qd frame). All rotor parameters and electrical quantities are viewed from the stator. They are identified by primed variables. The subscripts used are defined as follows:

- d, q : d and q axis quantity
- R, s : Rotor and stator quantity
- l, m : Leakage and magnetizing inductance
- f, k : Field and damper winding quantity

The electrical model of the machine is

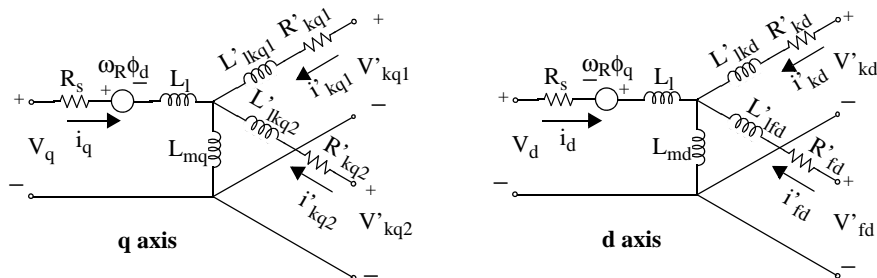

with the following equations.

Synchronous Machine

$$\begin{aligned}V_d &= R_s i_d + \frac{d}{dt} \varphi_d - \omega_R \varphi_q \\V_q &= R_s i_q + \frac{d}{dt} \varphi_q + \omega_R \varphi_d \\V'_{fd} &= R'_{fd} i'_{fd} + \frac{d}{dt} \varphi'_{fd} \\V'_{kd} &= R'_{kd} i'_{kd} + \frac{d}{dt} \varphi'_{kd} \\V'_{kq1} &= R'_{kq1} i'_{kq1} + \frac{d}{dt} \varphi'_{kq1} \\V'_{kq2} &= R'_{kq2} i'_{kq2} + \frac{d}{dt} \varphi'_{kq2}\end{aligned}$$
$$\begin{aligned}\varphi_d &= L_d i_d + L_{md} (i'_{fd} + i'_{kd}) \\ \varphi_q &= L_q i_q + L_{mq} i'_{kq} \\ \varphi'_{fd} &= L'_{fd} i'_{fd} + L_{md} (i_d + i'_{kd}) \\ \varphi'_{kd} &= L'_{kd} i'_{kd} + L_{md} (i_d + i'_{fd}) \\ \varphi'_{kq1} &= L'_{kq1} i'_{kq1} + L_{mq} i_q \\ \varphi'_{kq2} &= L'_{kq2} i'_{kq2} + L_{mq} i_q\end{aligned}$$

Note that this model assumes currents flowing into the stator windings. The measured stator currents returned by the Synchronous Machine block (Ia, Ib, Ic, Id, Iq) are the currents flowing out of the machine.

Dialog Box and Parameters

In the **powerlib** library you can choose between three Synchronous Machine blocks to specify the parameters of the model.

Fundamental Parameters in SI Units

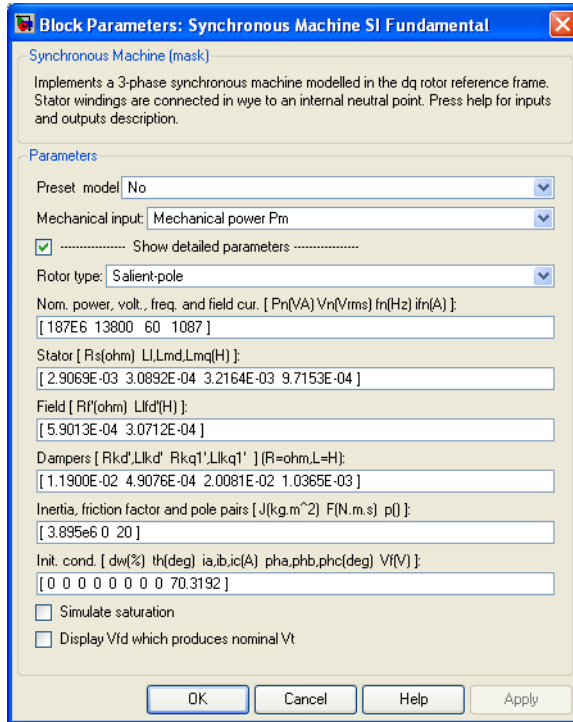

Preset model

Provides a set of predetermined electrical and mechanical parameters for various synchronous machine ratings of power (kVA), phase-to-phase voltage (V), frequency (Hz), and rated speed (rpm).

Select one of the preset models to load the corresponding electrical and mechanical parameters in the entries of the dialog box. Select No if you don't want to use a preset model.

Select **Show detailed parameters** to view and edit the detailed parameters associated with the preset model.

Synchronous Machine

Mechanical input

Allows you to select either the torque applied to the shaft or the rotor speed as the Simulink signal applied to the block's input.

Select **Torque T_m** to specify a torque input, in N.m or in p.u., and change labeling of the block's input to T_m . The machine speed is determined by the machine Inertia J (or inertia constant H for the p.u. machine) and by the difference between the applied mechanical torque T_m and the internal electromagnetic torque T_e . The sign convention for the mechanical torque is the following: when the speed is positive, a positive torque signal indicates generator mode and a negative signal indicates motor mode.

Select **Speed w** to specify a speed input, in rad/s or in p.u., and change labeling of the block's input to w . The machine speed is imposed and the mechanical part of the model (inertia constant H) is ignored. Using the speed as the mechanical input allows modeling a mechanical coupling between two machines and interfacing with SimMechanics and SimDriveline

The next figure indicates how to model a stiff shaft interconnection in a motor-generator. The speed output of machine 1 (motor) is connected to the speed input of machine 2 (generator), while machine 2 electromagnetic torque output T_e is applied to the mechanical torque input T_m of machine 1. The K_w factor takes into account speed units of both machines (pu or rad/s) and gear box ratio. The K_T factor takes into account torque units of both machines (pu or N.m) and machine ratings. Also, as the inertia J_2 is ignored in machine 2, J_2 referred to machine 1 speed must be added to machine 1 inertia J_1 .

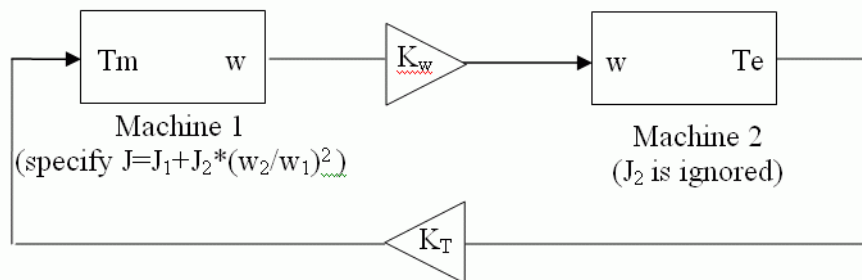

Show detailed parameters

If selected, the mask displays the detailed parameters of the Synchronous Machine block. The detailed parameters can be modified no matter the preset model you selected in the **Preset model** list.

Rotor type

Specify rotor type: Salient-pole or Round (cylindrical). This choice affects the number of rotor circuits in the q-axis (damper windings).

Nominal power, voltage, frequency, and field current

The total three-phase apparent power P_n (VA), RMS line-to-line voltage V_n (V), frequency f_n (Hz), and field current if_n (A).

The nominal field current is the current that produces nominal terminal voltage under no-load conditions. This model was developed with all quantities viewed from the stator. The nominal field current makes it possible to compute the transformation ratio of the machine, which allows you to apply the field voltage viewed from the rotor, as in real life. This also allows the field current, which is a variable in the output vector of the model, to be viewed from the rotor. If the value of the nominal field current is not known, you must enter 0 or leave it blank. Since the transformation ratio cannot be determined in this case, you have to apply the field voltage as viewed from the stator and the field current in the output vector is also viewed from the stator.

Stator

The resistance R_s (Ω), leakage inductance L_l (H), and d-axis and q-axis magnetizing inductances L_{md} (H) and L_{mq} (H).

Field

The field resistance R_f (Ω) and leakage inductance L_{lfd} (H), both referred to the stator.

Dampers

The d-axis resistance R_{kd} (Ω) and leakage inductance L_{lkd} (H), the q-axis resistance R_{kq1} (Ω) and leakage inductance L_{lkq1} (H), and (only if round rotor) the q-axis resistance R_{kq2} (Ω) and leakage inductance L_{lkq2} (H). All these values are referred to the stator.

Synchronous Machine

Inertia, friction factor, and pole pairs

The inertia coefficient J ($\text{kg}\cdot\text{m}^2$), friction factor F ($\text{N}\cdot\text{m}\cdot\text{s}$), and number of pole pairs p . The friction torque T_f is proportional to the rotor speed ω ($T_f = F\cdot\omega$, where T_f is expressed in $\text{N}\cdot\text{m}$, F in $\text{N}\cdot\text{m}\cdot\text{s}$, and ω in rad/s).

Initial conditions

The initial speed deviation $\Delta\omega$ (% of nominal speed), electrical angle of the rotor θ_e (degrees), line current magnitudes i_a , i_b , i_c (A) and phase angles pha , phb , phc (degrees), and the initial field voltage V_f (V).

You can specify the initial field voltage in one of two ways. If you know the nominal field current (first line, last parameter), enter in the dialog box the initial field voltage in volts DC referred to the rotor. Otherwise, enter a zero as nominal field current, as explained earlier, and specify the initial field voltage in volts DC referred to the stator. You can determine the nominal field voltage viewed from the stator by selecting the **Display Vfd which produces a nominal Vt** check box at the bottom of the dialog box.

Simulate saturation

Specifies whether magnetic saturation of rotor and stator iron is to be simulated or not.

Saturation parameters

The no-load saturation curve parameters. Magnetic saturation of stator and rotor iron is modeled by a nonlinear function (in this case a polynomial) using points on the no-load saturation curve. You must enter a 2-by- n matrix, where n is the number of points taken from the saturation curve. The first row of this matrix contains the values of field currents, while the second row contains values of corresponding terminal voltages. The first point (first column of the matrix) must correspond to the point where the effect of saturation begins.

You must select the **Simulate saturation** check box to simulate saturation. This check box allows you to enter the matrix of parameters for simulating the saturation. If you do not want to model saturation in your simulation, do not select the **Simulate saturation** check box. In this case the relationship between i_{fd} and V_t obtained is linear (no saturation).

Display Vfd which produces a nominal Vt

Select to determine the nominal field voltage viewed from the stator.

Synchronous Machine

As an example, without saturation, a typical curve might be as shown below. Here i_{fn} is 1087 A and V_n is 13800 V RMS line-to-line, which is also 11268 V peak line-to-neutral.

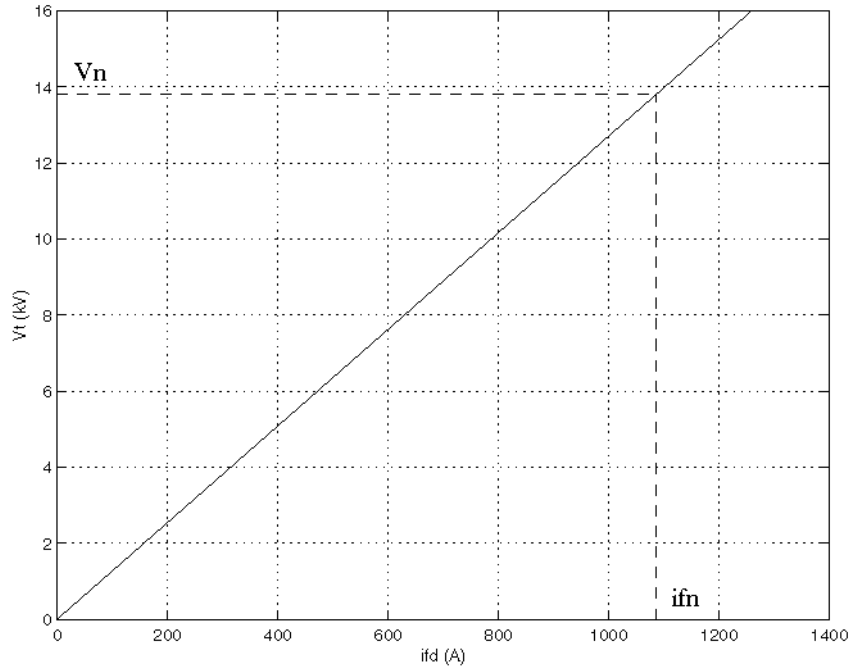

Saturation is modeled by fitting a polynomial to the curve corresponding to the matrix of points you enter. The more points you enter, the better the fit to the original curve.

Synchronous Machine

The next figure illustrates goodness of fit graphically (the diamonds are the actual points entered in the dialog box).

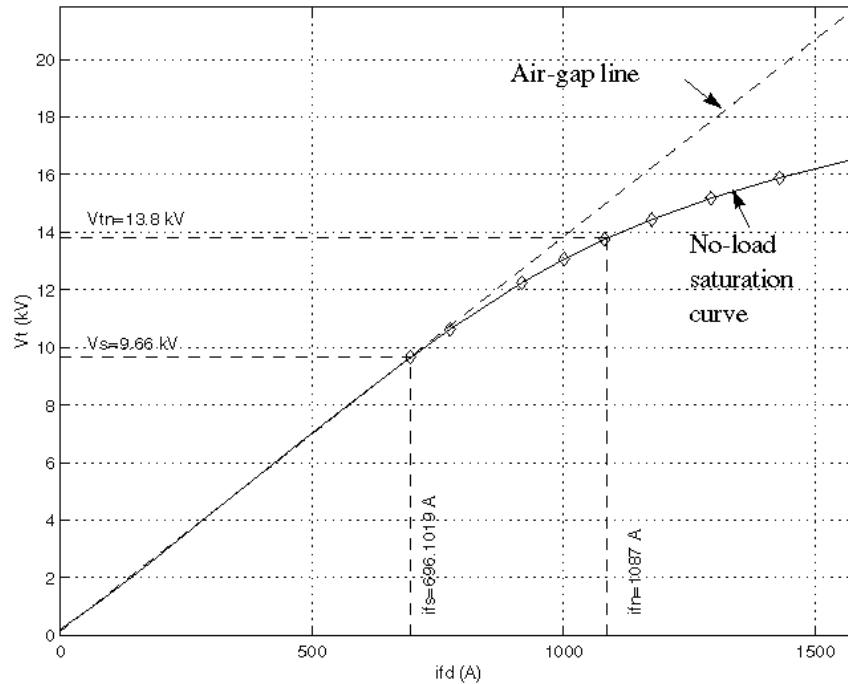

In this particular case, the following values were used:

i_{fn}	1087 A
i_{fd}	[695.64, 774.7, 917.5, 1001.6, 1082.2, 1175.9, 1293.6, 1430.2, 1583.7] A
V_t	[9660, 10623, 12243, 13063, 13757, 14437, 15180, 15890, 16567] V

Fundamental Parameters in p.u.

Block Parameters: Synchronous Machine pu Fundamental

Synchronous Machine [mask]
Implements a 3-phase synchronous machine modelled in the dq rotor reference frame. Stator windings are connected in wye to an internal neutral point.

Parameters

Preset model: No

Mechanical input: Mechanical power Pm

Show detailed parameters

Rotor type: Salient-pole

Nom. power, L-L volt. and freq. [Pn(VA) Vn(Vrms) fn(Hz)]:
[187E6 13800 60]

Stator [R_s L_l L_{md} L_{mq}] (pu):
[2.85E-03 0.114 1.19 0.36]

Field [R_f L_{fd}] (pu):
[5.79E-04 0.114]

Dampers [R_kd L_kd R_kq1 L_kq1] (pu):
[1.17E-02 0.182 1.97E-02 0384]

Coeff. of inertia, friction factor and pole pairs [H(s) F(pu) p]:
[3.7 0 20]

Init. cond. [dw(%) th(deg) ia,ib,ic(pu) pha,phb,phc(deg) Vf(pu)]:
[0 0 0 0 0 0 0 0 1]

Simulate saturation

OK Cancel Help Apply

Preset model

Provides a set of predetermined electrical and mechanical parameters for various synchronous machine ratings of power (kVA), phase-to-phase voltage (V), frequency (Hz), and rated speed (rpm).

Select one of the preset models to load the corresponding electrical and mechanical parameters in the entries of the dialog box. Select No if you don't want to use a preset model.

Select **Show detailed parameters** to view and edit the detailed parameters associated with the preset model.

Mechanical input

Refer to the **Mechanical input** parameter of the Fundamental SI parameters mask of the Synchronous Machine block.

Synchronous Machine

Show detailed parameters

If selected, the mask displays the detailed parameters of the Synchronous Machine block. The detailed parameters can be modified no matter the preset model you selected in the **Preset model** list.

Rotor type

Specifies rotor type: Salient-pole or Round (cylindrical).

Nominal power, L-L voltage, and frequency

Total three-phase apparent power (VA), RMS line-to-line voltage (V), frequency (Hz), and field current (A).

This line is identical to the first line of the fundamental parameters in SI dialog box, except that you do not specify a nominal field current. This value is not required here because we do not need the transformation ratio. Since rotor quantities are viewed from the stator, they are converted to p.u. using the stator base quantities derived from the preceding three nominal parameters.

Stator; Field; Dampers

Contain exactly the same parameters as in the previous dialog box, but they are expressed here in p.u. instead of SI units.

Coefficient of inertia, friction factor, and pole pairs

The inertia constant H (s), where H is the ratio of energy stored in the rotor at nominal speed over the nominal power of the machine, the friction factor F (p.u. torque/p.u. speed), and the number of pole pairs p . The friction torque T_f is proportional to the rotor speed ω ($T_f = F \cdot \omega$, where all quantities are expressed in p.u.).

Initial conditions; Simulate saturation; Saturation parameters

The same initial conditions and saturation parameters as in the S.I. units dialog box, but all values are expressed in p.u. instead of SI units. For saturation, the nominal field current multiplied by the d-axis magnetizing inductance and nominal RMS line-to-line voltage are the base values for the field current and terminal voltage, respectively.

Standard Parameters in p.u.

Block Parameters: Synchronous Machine pu Standard

Synchronous Machine [mask]
Implements a 3-phase synchronous machine modelled in the dq rotor reference frame.
Stator windings are connected in wye to an internal neutral point.

Parameters

Preset model: No

Mechanical input: Mechanical power Pm

Show detailed parameters

Rotor type: Salient-pole

Nom. power, L-L volt. and freq. [Pn(VA) Vn(Vrms) fn(Hz)]:
[187E6 13800 60]

Reactances [Xd Xd' Xd'' Xq Xq' Xq''] (pu):
[1.305, 0.296, 0.252, 0.474, 0.243, 0.18]

d axis time constants: Open-circuit

q axis time constant(s): Short-circuit

Time constants [T do' T do'' T q''] (s):
[4.49 0.0681 0.0513]

Stator resistance Rs (p.u.):
0.003

Coeff. of inertia, friction factor and pole pairs [H(s) F(pu) p()]:
[3.7 0 20]

Init. cond. [dw(%) th(deg) ia,ib,ic(pu) pha,phb,phc(deg) Vt(pu)]:
[0 0 0 0 0 0 0 0 1]

Simulate saturation

Saturation parameters [ifd1,ifd2,... (p.u.) ; vt1,vt2,... (p.u.)]:
[56,1.082,1.19,1.316,1.457,0.7,0.7698,0.8872,0.9466,0.9969,1.046,1.1,1.1,1.151,1.201]

OK Cancel Help Apply

Preset model

Provides a set of predetermined electrical and mechanical parameters for various synchronous machine ratings of power (kVA), phase-to-phase voltage (V), frequency (Hz), and rated speed (rpm).

Select one of the preset models to load the corresponding electrical and mechanical parameters in the entries of the dialog box. Select No if you don't want to use a preset model.

Select **Show detailed parameters** to view and edit the detailed parameters associated with the preset model.

Synchronous Machine

Mechanical input

Refer to the **Mechanical input** parameter of the Fundamental SI parameters mask of the Synchronous Machine block.

Show detailed parameters

If selected, the mask displays the detailed parameters of the Synchronous Machine block. The detailed parameters can be modified no matter the preset model you selected in the **Preset model** list.

Rotor type; Nominal power, L-L voltage, and frequency

The same parameters as the fundamental p.u. dialog box.

Reactances

The d-axis synchronous reactance X_d , transient reactance X_d' , and subtransient reactance X_d'' , the q-axis synchronous reactance X_q , transient reactance X_q' (only if round rotor), and subtransient reactance X_q'' , and finally the leakage reactance X_l (all in p.u.).

d-axis time constants; q-axis time constant(s)

Specify the time constants you supply for each axis: either open-circuit or short-circuit.

Time constants

The d-axis and q-axis time constants (all in s). These values must be consistent with choices made on the two previous lines: d-axis transient open-circuit (T_{do}') or short-circuit (T_d') time constant, d-axis subtransient open-circuit (T_{do}'') or short-circuit (T_d'') time constant, q-axis transient open-circuit (T_{qo}') or short-circuit (T_q') time constant (only if round rotor), q-axis subtransient open-circuit (T_{qo}'') or short-circuit (T_q'') time constant.

Stator resistance

The stator resistance R_s (p.u.).

Coefficient of inertia, friction factor, and pole pairs; Initial conditions; Simulate saturation; Saturation parameters

The same parameters as the fundamental parameters in p.u. dialog box.

Note These three blocks simulate exactly the same synchronous machine model; the only difference is the way of entering the parameter units.

Inputs and Outputs

The units of inputs and outputs vary according to which dialog box was used to enter the block parameters. If the fundamental parameters in SI units is used, the inputs and outputs are in SI units (except for dw in the vector of internal variables, which is always in p.u., and angle θ , which is always in rad). Otherwise, the inputs and outputs are in p.u.

P_m

The first Simulink input is the mechanical power at the machine's shaft. In generating mode, this input can be a positive constant or function or the output of a prime mover block (see the Hydraulic Turbine and Governor or Steam Turbine and Governor blocks). In motoring mode, this input is usually a negative constant or function.

V_f

The second Simulink input of the block is the field voltage. This voltage can be supplied by a voltage regulator in generator mode (see the Excitation System block). It is usually a constant in motor mode.

If you use the model in SI fundamental units, the field voltage V_f should be entered in volts DC if nominal field current I_{fn} is specified or in volts referred to stator if I_{fn} is not specified. To obtain the V_{fd} producing nominal voltage, select the last check box of the dialog box. If you use the model in p.u. Standard or in p.u. Fundamental units, V_f should be entered in p.u. (1 p.u. of field voltage producing 1 p.u. of terminal voltage at no load).

Synchronous Machine

m

The Simulink output of the block is a vector containing 22 signals. You can demultiplex these signals by using the Bus Selector block provided in the Simulink library.

Signal	Definition	Units
1	Stator current is_a	A or p.u.
2	Stator current is_b	A or p.u.
3	Stator current is_c	A or p.u.
4	Stator current is_q	A or p.u.
5	Stator current is_d	A or p.u.
6	Field current ifd	A or p.u.
7	Damper winding current $ikq1$	A or p.u.
8	Damper winding current $ikq2$	A or p.u.
9	Damper winding current ikd	A or p.u.
10	Mutual flux $phimq$	V.s or p.u.
11	Mutual flux $phimd$	V.s or p.u.
12	Stator voltage vq	V or p.u.
13	Stator voltage vd	V or p.u.
14	Rotor angle deviation d_theta	rad
15	Rotor speed wm	rad/s.
16	Electrical power Pe	VA or p.u.
17	Rotor speed deviation dw	rad/s
18	Rotor mechanical angle $theta$	rad
19	Electromagnetic torque Te	N.m or p.u.

Signal	Definition	Units
20	Load angle δ	N.m or p.u.
21	Output active power P_{eo}	rad
22	Output reactive power Q_{eo}	rad

Limitations

When you use Synchronous Machine blocks in discrete systems, you might have to use a small parasitic resistive load, connected at the machine terminals, in order to avoid numerical oscillations. Large sample times require larger loads. The minimum resistive load is proportional to the sample time. As a rule of thumb, remember that with a 25 ms time step on a 60 Hz system, the minimum load is approximately 2.5% of the machine nominal power. For example, a 200 MVA synchronous machine in a power system discretized with a 50 ms sample time requires approximately 5% of resistive load or 10 MW. If the sample time is reduced to 20 ms, a resistive load of 4 MW should be sufficient.

Example

The `power_syncmachine` demo illustrates the use of the Synchronous Machine block in motor mode. The simulated system consists of an industrial grade synchronous motor (150 HP (112 kVA), 762 V) connected to a network with a 10 MVA short-circuit level. In order to start simulation in steady state, the machine is initialized using the **Load Flow and Machine Initialization** option of the Powergui. The machine is initialized for an output electrical power of -50 kW (negative value for motor mode), corresponding to a mechanical power of -48.9 kW. The corresponding values of mechanical power and field voltage have been automatically entered by the **Load Flow** analysis into the Pm Step block and in the Vf Constant block. The Pm Step block has been programmed in order to apply a sudden increase of mechanical power from -48.9 kW to -60 kW at time $t = 0.1$ s.

Synchronous Machine

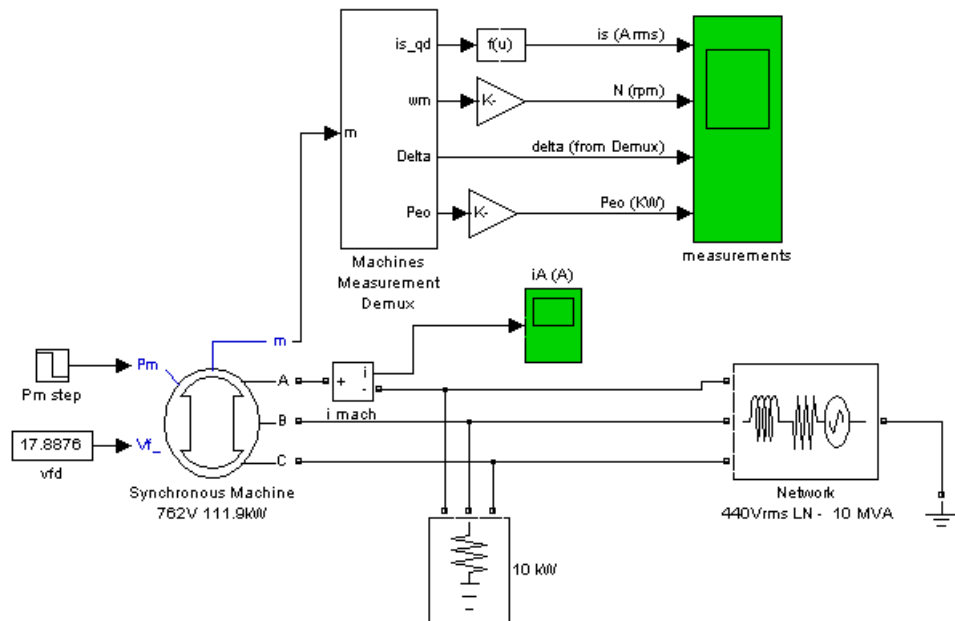

Run the simulation and observe the RMS current, RMS voltage, speed, load angle δ , and output electrical power of the motor.

Since this is a four-pole machine, the nominal speed is 1800 rpm. The initial speed is 1800 rpm as prescribed. After the load has increased from 48.9 kW to 100 kW at $t = 0.1$ s, the machine speed oscillates before stabilizing to 1800 rpm. The load angle (angle between terminal voltage and internal voltage) increases from -21 degrees to -53 degrees.

References

- [1] Krause, P.C., *Analysis of Electric Machinery*, McGraw-Hill, 1986, Section 12.5.
- [2] Kamwa, I., et al., "Experience with Computer-Aided Graphical Analysis of Sudden-Short-Circuit Oscillograms of Large Synchronous Machines," *IEEE Transactions on Energy Conversion*, Vol. 10, No. 3, September 1995.

See Also

Excitation System, Hydraulic Turbine and Governor, Powergui, Simplified Synchronous Machine, Steam Turbine and Governor

Purpose

Implement a three-level neutral point clamped (NPC) power converter with selectable topologies and power switching devices

Library

Power Electronics

Description

The Three-Level Bridge block implements a three-level power converter that consists of one, two, or three arms of power switching devices. Each arm consists of four switching devices along with their antiparallel diodes and two neutral clamping diodes as shown in the figure below.

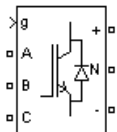
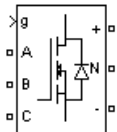
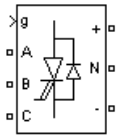

Three-Level Bridge

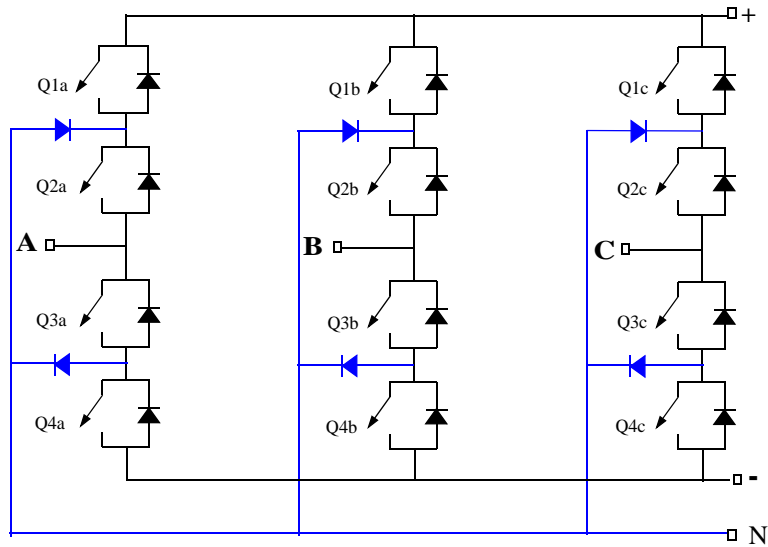
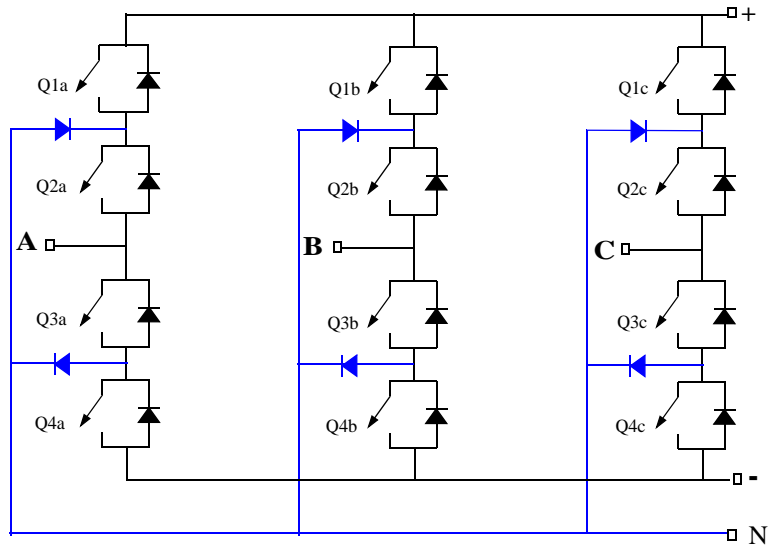

The type of power switching device (IGBT, GTO, MOSFET, or ideal switch) and the number of arms (one, two, or three) are selectable from the dialog box.

Three-Level Bridge

When the ideal switch is used as the switching device, the Three-Level Bridge block implements an ideal switch bridge having a three-level topology as shown.

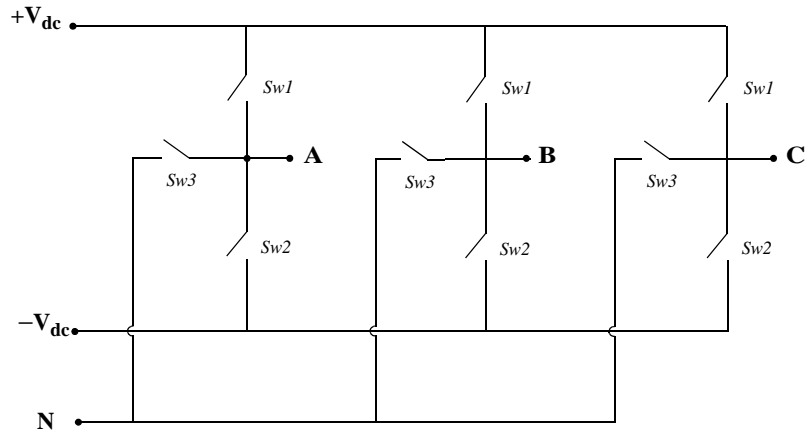

Dialog Box and Parameters

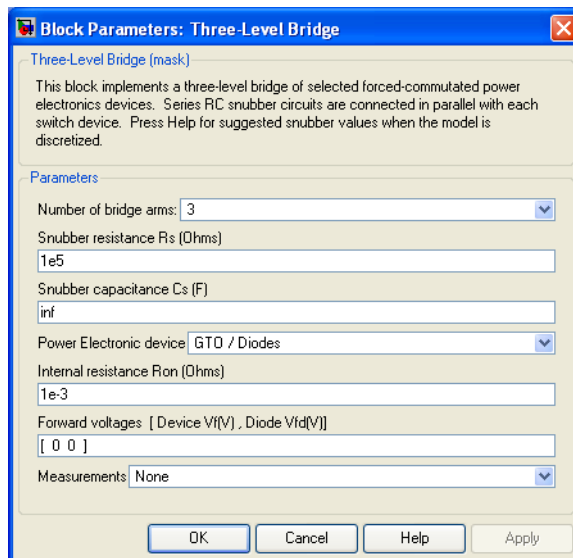

Three-Level Bridge

Number of bridge arms

Determine the bridge topology: one, two, or three arms.

Snubber resistance R_s

The snubber resistance, in ohms (Ω). Set the **Snubber resistance R_s** parameter to `inf` to eliminate the snubbers from the model.

Snubber capacitance C_s

The snubber capacitance, in farads (F). Set the **Snubber capacitance C_s** parameter to 0 to eliminate the snubbers, or to `inf` to get a resistive snubber.

For forced-commutated devices (GTO, IGBT, or MOSFET) the Three-Level Bridge block operates satisfactorily with resistive snubbers as long as the firing pulses are sent to the switching devices.

If the firing pulses to forced-commutated devices are blocked, the bridge operates as a diode rectifier. In this condition, you must use appropriate values of R_s and C_s . If the model is discretized, you can use the following formulas to compute approximate values of R_s and C_s :

$$R_s > 2 \frac{T_s}{C_s}$$

$$C_s < \frac{P_n}{1000(2\pi f)V_n^2}$$

where

P_n = Nominal power of single- or three-phase converter (VA)

V_n = Nominal line-to-line AC voltage (Vrms)

f = Fundamental frequency (Hz)

T_s = Sample Time (s)

These R_s and C_s values are derived from the following two criteria:

- The snubber leakage current at fundamental frequency is less than 0.1% of nominal current when power electronic devices are not conducting.
- The RC time constant of snubbers is higher than two times the sample time T_s .

Note that the R_s and C_s values that guarantee numerical stability of the discretized bridge can be different from actual values used in the physical circuit.

Power electronic device

Select the type of power electronic device to use in the bridge.

Internal resistance R_{on}

Internal resistance of the selected devices and diodes, in ohms (Ω).

Forward voltages [Device V_f , Diode V_{fd}]

The forward voltage of the selected devices (for GTO or IGBT only) and of the antiparallel and clamping diodes, in volts.

Measurements

Select `All Device currents` to measure the current flowing through all the components (switching devices and diodes). If the snubber devices are defined, the measured currents are those flowing through the power electronic devices only.

Select `Phase-to-neutral` and `DC voltages` to measure the terminal voltages (AC and DC) of the Three-Level Bridge block.

Select `All voltages` and `currents` to measure all voltages and currents defined for the Three-Level Bridge block.

Place a `Multimeter` block in your model to display the selected measurements during the simulation. In the **Available Measurement** list box of the `Multimeter` block, the measurement is identified by a label followed by the block name.

Measurement	Label (for GTO, IGBT, MOSFET Devices)
Device currents	IQ1a, IQ2a, IQ3a, IQ4a, IQ1b, IQ2b, IQ3b, IQ4b, IQ1c, IQ2c, IQ3c, IQ4c, ID1a, ID2a, ID3a, ID4a, ID5a, ID6a, ID1b, ID2b, ID3b, ID4b, ID5b, ID6b, ID1c, ID2c, ID3c, ID4c, ID5c, ID6c
Terminal voltages	Uan:, Ubn:, Ucn:, Udc+:, Udc-:

Three-Level Bridge

Measurement	Label (for Ideal Switch Device)
Device currents	Isw1a, Isw2a, Isw3a, Isw1b, Isw2b, Isw3b, Isw1c, Isw2c, Isw3c
Terminal voltages	Uan:, Ubn:, Ucn:, Udc+:, Udc-:

Inputs and Outputs

The input *g* is a vectorized gating signal containing pulses to control the power electronic devices of the bridge. The length of the input vector depends on the number of arm you specified for the bridge topology.

Topology	Pulse Vector of Input <i>g</i>
One arm	[Q1a, Q2a, Q3a, Q4a]
Two arms	[Q1a, Q2a, Q3a, Q4a, Q1b, Q2b, Q3b, Q4b]
Three arms	[Q1a, Q2a, Q3a, Q4a, Q1b, Q2b, Q3b, Q4b, Q1c, Q2c, Q3c, Q4c]

Note In the case of the ideal switch converter, the Q1 pulse is sent to Sw1, the Q4 pulse to Sw2, and a logical AND operation is performed on the Q2 and Q3 pulses and the result sent to Sw3.

Assumptions and Limitations

Turn-on and turn-off times (Fall time, Tail time) of power switching devices are not modeled in the Three-Level Bridge block.

Example

The `power_3levelVSC` demo illustrates the use of the Three-Level Bridge block in an AC-DC converter consisting of a three-phase IGBT-based voltage sourced converter (VSC). The converter is pulse-width modulated (PWM) to produce a 500 V DC voltage (+/- 250 V). In this example, the converter chopping frequency is 1620 Hz and the power system frequency is 60 Hz.

Three-Level Bridge

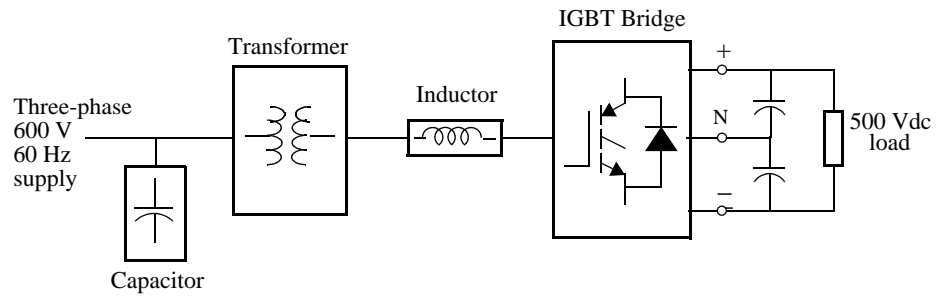

The VSC is controlled in a closed loop by two PI regulators in order to maintain a DC voltage of 500 V at the load while maintaining a unity input power factor for the AC supply.

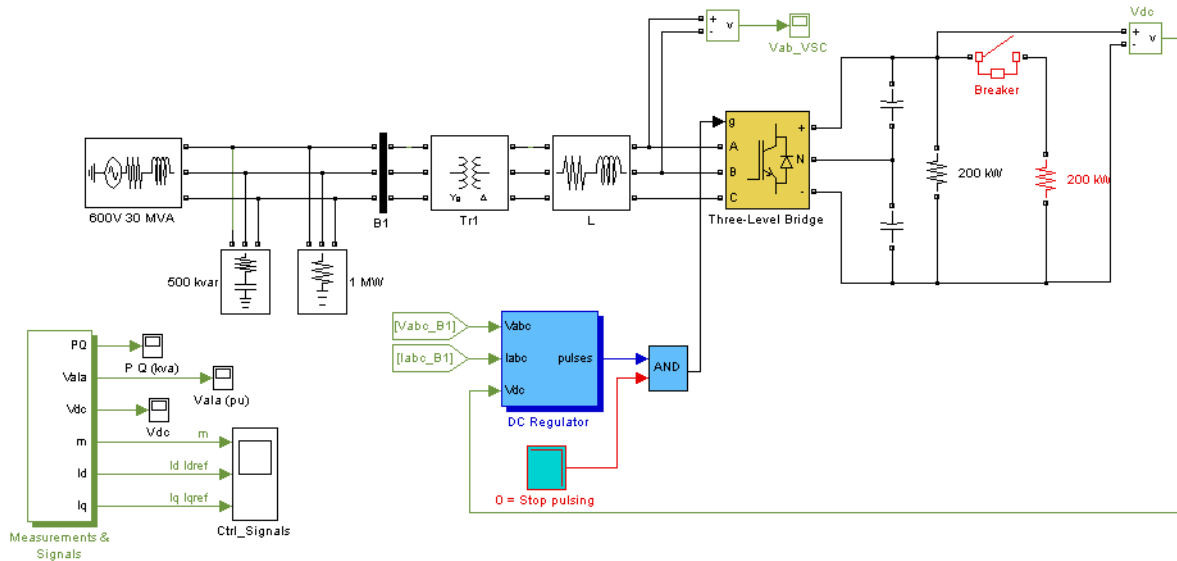

The initial conditions for a steady-state simulation are generated by running an initial simulation to steady state for an integer number of cycles of 60 Hz. The final states (both SimPowerSystems and Simulink controller states) are saved in a vector called `xInitial`. This vector, as well as the sample times (`Ts_Power` and `Ts_Control`) are saved in the `power_3levelVSC_xinit.mat` file.

Three-Level Bridge

When you open this model, the initial condition vector `xInitial` and the sample times saved in the MAT file are automatically loaded in the workspace. Start the simulation. The monitored signals start in steady state.

Observe the following signals:

- The DC voltage (Vdc Scope block)
- The primary voltage and current of phase A of the AC supply (VaIa Scope block)
- The device currents of leg A of the IGBT bridge (Ia_Devices Scope block inside the Measurements & Signals subsystem)
- The line-to-line terminal voltage of the VSC (Vab_VSC Scope block)

At 50 ms, a 200 kW load is switched in. You can see that the dynamic response of the DC regulator to the sudden load variation from 200 kW to 400 kW is satisfactory. The DC voltage reverts to 500 V within 2 cycles and the unity power factor on the AC side is maintained.

At 100 ms, a *stop-pulsing* signal is activated and the pulses normally sent to the converter are blocked. You can see that the DC voltage drops to 315 V. A drastic change in the primary current waveform can also be observed. When the pulses are blocked, the Three-Level Bridge block operation becomes similar to a three-phase diode bridge.

Three-Level Bridge

The following two figures summarize the results of the simulation. The first figure shows the operation of the AC-DC converter during the load variation and when the pulses are blocked.

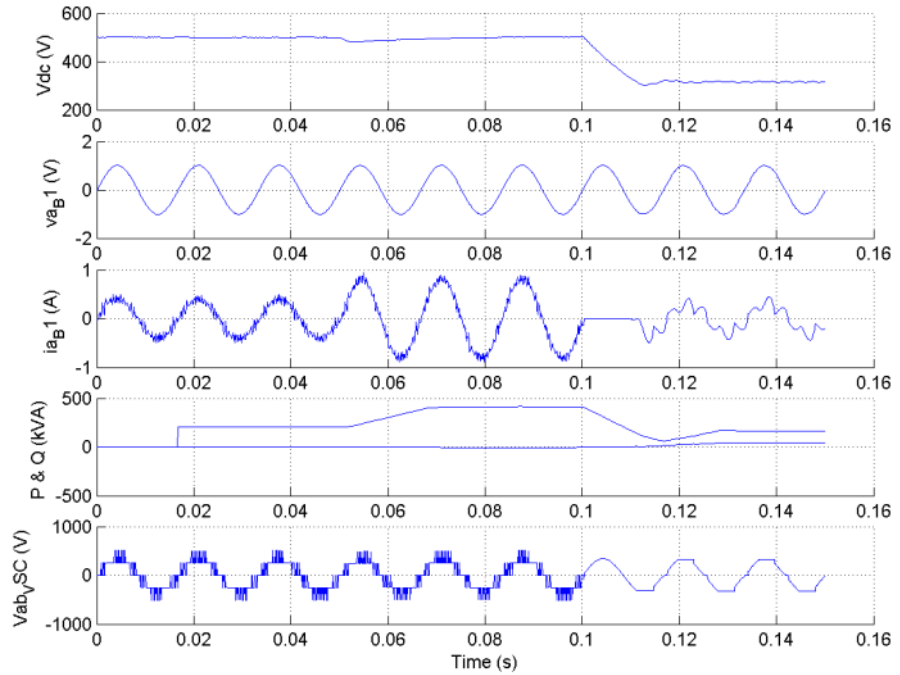

Three-Level Bridge

The second figure shows the current flowing in the various devices of the IGBT bridge when the converter is feeding 500 Vdc to a 200-kW load.

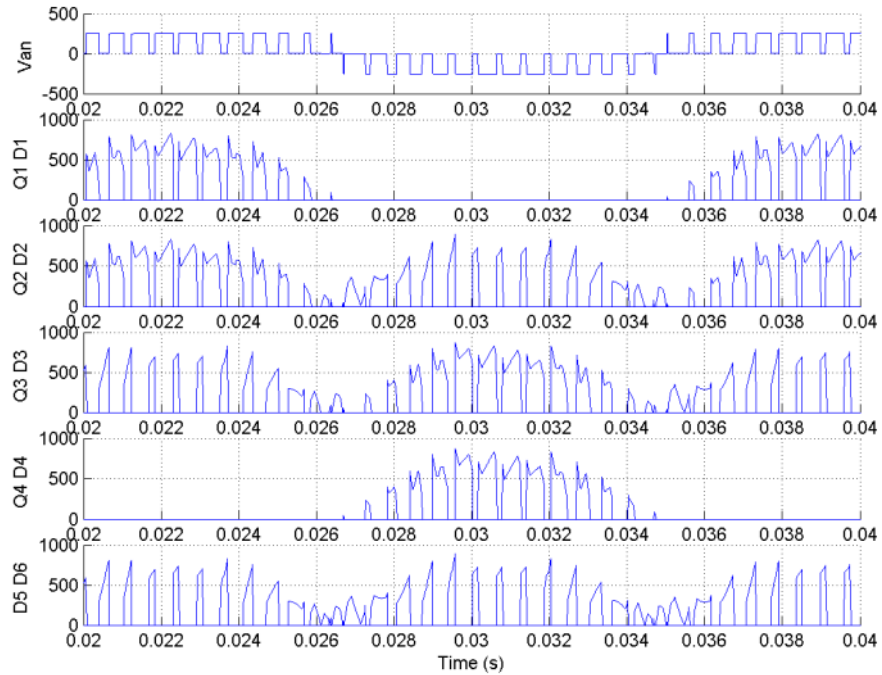

See Also

Multimeter

Purpose Implement a three-phase circuit breaker opening at the current zero crossing

Library Elements

Description

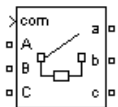
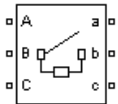

The Three-Phase Breaker block implements a three-phase circuit breaker where the opening and closing times can be controlled either from an external Simulink signal (external control mode), or from an internal control timer (internal control mode).

The Three-Phase Breaker block uses three Breaker blocks connected between the inputs and the outputs of the block. You can use this block in series with the three-phase element you want to switch. See the Breaker block reference pages for details on the modeling of the single-phase breakers.

If the Three-Phase Breaker block is set in external control mode, a control input appears in the block icon. The control signal connected to this input must be either 0 or 1, 0 to open the breakers, 1 to close them. If the Three-Phase Breaker block is set in internal control mode, the switching times are specified in the dialog box of the block. The three individual breakers are controlled with the same signal.

Series Rs-Cs snubber circuit are included in the model. They can be optionally connected to the three individual breakers. If the Three-Phase Breaker block happens to be in series with an inductive circuit, an open circuit or a current source, you must use the snubbers.

Three-Phase Breaker

Dialog Box and Parameters

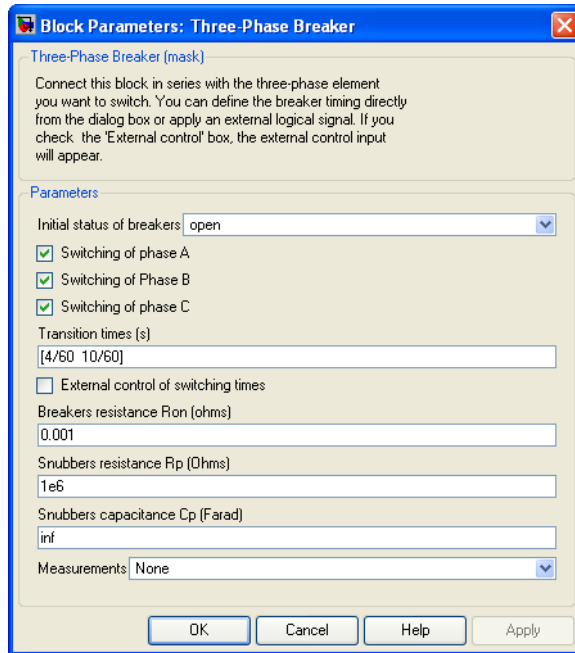

Initial status of breakers

The initial status of the breakers. The initial status is the same for the three breakers. Depending on the initial status, the icon shows a closed contact or an open contact.

Switching of phase A

If selected, the switching of phase A is activated. If not selected, the breaker of phase A stays in its initial status specified in the **Initial status of breakers** parameter.

Switching of Phase B

If selected, the switching of phase B is activated. If not selected, the breaker of phase B stays in its initial status specified in the **Initial status of breakers** parameter.

Switching of phase C

If selected, the switching of phase C is activated. If not selected, the breaker of phase C stays in its initial status specified in the **Initial status of breakers** parameter.

Transition times(s)

The **Transition times(s)** parameter is not visible in the dialog box if the **External control of switching times** parameter is selected.

Specify the vector of switching times when using the Three-Phase Breaker block in internal control mode. At each transition time the selected breakers opens or closes depending to their initial state.

External control of switching times

If selected, adds a fourth input port to the Three-Phase Breaker block for an external control of the switching times of the breakers. The switching times are defined by a Simulink signal (0-1 sequence).

Breakers resistance Ron

The internal breaker resistances, in ohms (Ω). The **Breaker resistance Ron** parameter cannot be set to 0.

Snubbers resistance Rp

The snubber resistances, in ohms (Ω). Set the **Snubber resistance Rp** parameter to `inf` to eliminate the snubbers from the model.

Snubbers capacitance Cp

The snubber capacitances, in farads (F). Set the **Snubber capacitance Cp** parameter to 0 to eliminate the snubbers, or to `inf` to get resistive snubbers.

Measurements

Select Breaker voltages to measure the voltage across the three internal breaker terminals.

Select Breaker currents to measure the current flowing through the three internal breakers. If the snubber devices are connected, the measured currents are the ones flowing through the breakers contacts only.

Select Breaker voltages and currents to measure the breaker voltages and the breaker currents.

Three-Phase Breaker

Place a Multimeter block in your model to display the selected measurements during the simulation. In the **Available Measurements** list box of the Multimeter block, the measurements is identified by a label followed by the block name and the phase:

Measurement	Label
Breaker voltages	Ub <block name> /Breaker A: Ub <block name> /Breaker B: Ub <block name> /Breaker C.
Breaker currents	Ib <block name> /Breaker A: Ib <block name> /Breaker B: Ib <block name> Breaker C.

Inputs and Outputs

If the Three-Phase Breaker block is set in external control mode, a Simulink input is added to the block to control the opening and closing of the three internal breakers.

Example

See the `power_3phlinereclose` and `power_3phseriescomp` demos for circuits using the Three-Phase Breaker block.

See Also

Breaker, Multimeter, Three-Phase Fault

Purpose

Implement a three-phase dynamic load with active power and reactive power as a function of voltage or controlled from an external input

Library

Elements

Description

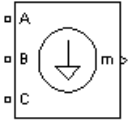

The Three-Phase Dynamic Load block implements a three-phase, three-wire dynamic load whose active power P and reactive power Q vary as function of positive-sequence voltage. Negative- and zero-sequence currents are not simulated. The three load currents are therefore balanced, even under unbalanced load voltage conditions.

The load impedance is kept constant if the terminal voltage V of the load is lower than a specified value V_{min} . When the terminal voltage is greater than the V_{min} value, the active power P and reactive power Q of the load vary as follows:

$$P(s) = P_o \left(\frac{V}{V_o} \right)^{n_p} \frac{(1 + T_{p1}s)}{(1 + T_{p2}s)}$$

$$Q(s) = Q_o \left(\frac{V}{V_o} \right)^{n_q} \frac{(1 + T_{q1}s)}{(1 + T_{q2}s)}$$

where

- V_o is the initial positive sequence voltage.
- P_o and Q_o are the initial active and reactive powers at the initial voltage V_o .
- V is the positive-sequence voltage.
- n_p and n_q are exponents (usually between 1 and 3) controlling the nature of the load.
- T_{p1} and T_{p2} are time constants controlling the dynamics of the active power P .
- T_{q1} and T_{q2} are time constants controlling the dynamics of the reactive power Q .

For a constant current load, for example, you set n_p to 1 and n_q to 1, and for constant impedance load you set n_p to 2 and n_q to 2.

Three-Phase Dynamic Load

Dialog Box and Parameters

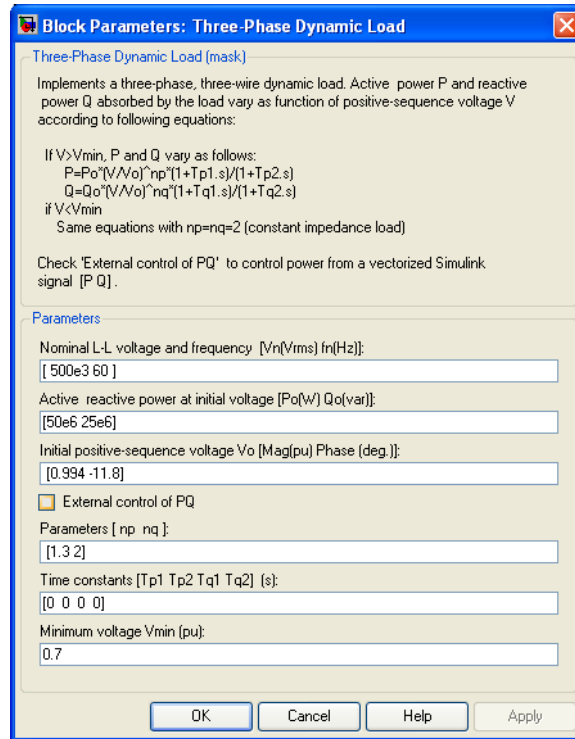

Nominal L-L voltage and frequency

Specifies the nominal phase-to-phase voltage, in volts RMS, and nominal frequency, in hertz, of the load.

Active and reactive power at initial voltage

Specifies the initial active power P_0 , in watts, and initial reactive power Q_0 , in vars, at the initial voltage V_0 . If the load flow utility of the Powergui is used to initialize the dynamic load and start simulation in steady state, these parameters are automatically updated according to P and Q set points specified for the load.

Initial positive-sequence voltage Vo

Specifies the magnitude and phase of the initial positive-sequence voltage of the load. If the load flow utility of the Powergui is used to initialize the

dynamic load and start simulation in steady state, these two parameters are automatically updated according to values computed by the load flow.

External control of PQ

If selected, the active power and reactive power of the load are defined by an external Simulink vector of two signals.

Parameters [np nq]

Specifies the **np** and **nq** parameters that define the nature of the load.

Time constants [Tp1 Tp2 Tq1 Tq2]

Specifies the time constants controlling the dynamics of the active power and the reactive power.

Minimum voltage Vmin

Specifies the minimum voltage at which the load dynamics commences. The load impedance is constant below this value.

Inputs and Outputs

If **External control of PQ** is selected, a Simulink input, labeled PQ, appears. This input is used to control the active and reactive powers of the load from a vector of two signals [P, Q].

The m output is a vector containing the following three signals: positive-sequence voltage (p.u.); active power P (W); and reactive power Q (vars).

Example

The power_dynamicload model uses a Three-Phase Dynamic Load block connected on a 500 kV, 60 Hz power network. The network is simulated by its Thevenin equivalent (voltage source behind a R-L impedance corresponding to a three-phase short-circuit level of 2000 MVA). The source internal voltage is modulated in order to simulate voltage variation during a power swing. As the dynamic load is a nonlinear model simulated by current sources, it cannot be connected to an inductive network (R-L in series). Therefore, a small resistive load (1 MW) has been added in parallel with the dynamic load.

Three-Phase Dynamic Load

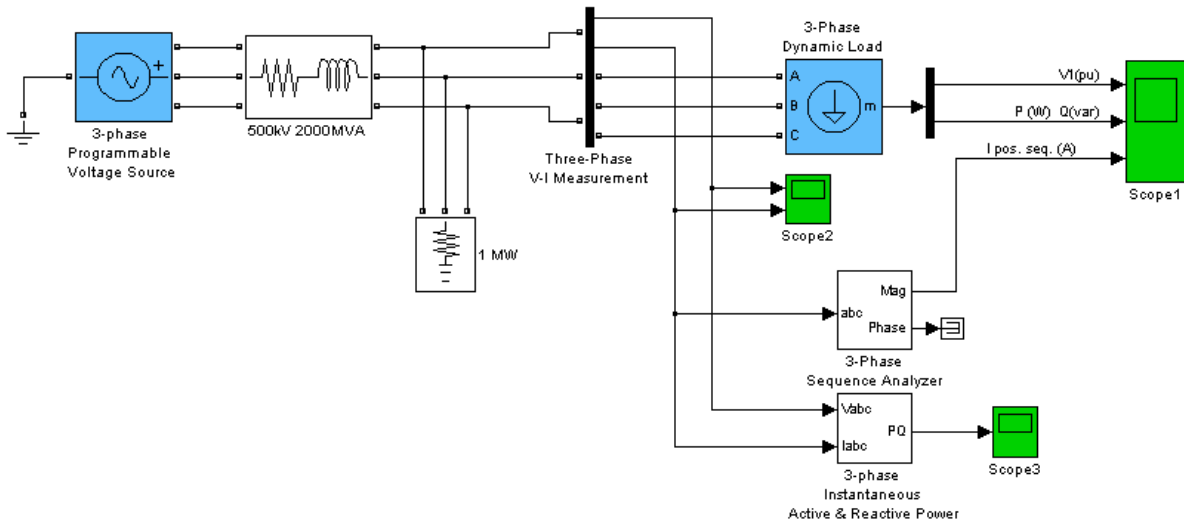

In order to start the simulation in steady state, you must specify the correct initial positive-sequence voltage V_0 (magnitude and phase) corresponding to the desired P_0 and Q_0 values. You use the load flow utility to find this voltage and initialize the dynamic load. Open the Powergui and select **Load Flow and Machine Initialization**. Specify the desired active power and reactive powers for the dynamic load (50 MW, 25 Mvar):

$$\text{Active Power} = 50\text{e}6; \text{Reactive Power} = 25\text{e}6$$

Then press the **Update Load Flow** button. Once the load flow has been solved the three phase-to-phase voltages of the dynamic load (0.9844 p.u.) as well as its line currents are displayed. The phase angle of the phase-to-neutral load voltage U_{an} is also displayed (-1.41 degrees). This angle corresponds to the angle of the positive-sequence voltage. If you now open the Three-Phase Dynamic Load dialog box, notice that the values of P_0 , Q_0 , and V_0 have been updated.

Three-Phase Dynamic Load

Start the simulation and observe load voltage, P&Q powers, and current on Scope1. Observe that simulation starts in steady state. At $t = 0.2$ s, when voltage modulation is initiated, P and Q start to increase (trace 2), but, as n_p and n_q are set to 1, the load current (trace 3) stays constant. When voltage falls below 0.7 p.u. the load behaves as a constant impedance. Therefore load current follows this voltage variation.

Observe on Scope2 variations of instantaneous voltages and currents. Also, notice that computed P and Q displayed on Scope3 are the same as P and Q internal signals returned by the Dynamic Load measurement output.

The signals displayed on the Scope1 block are shown below.

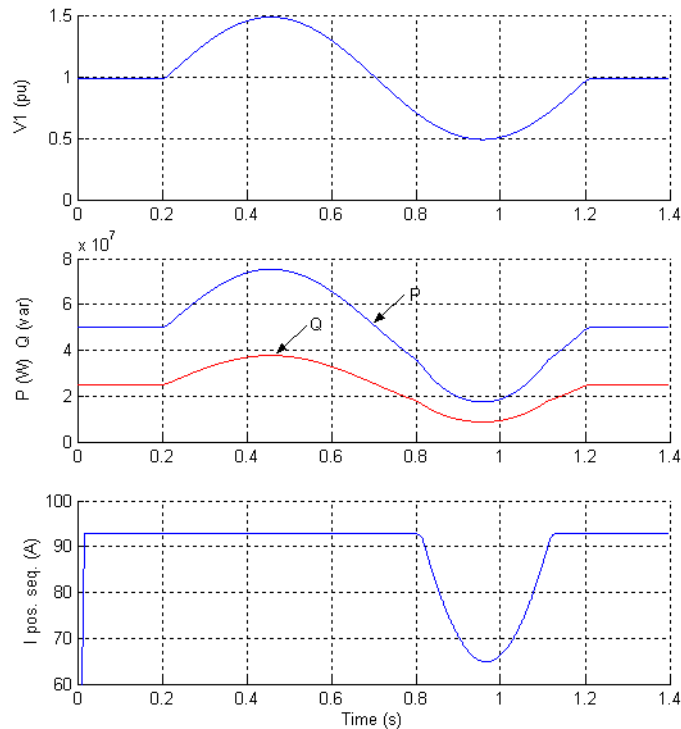

Three-Phase Fault

Purpose Implement a programmable phase-to-phase and phase-to-ground fault breaker system

Library Elements

Description



The Three-Phase Fault block implements a three-phase circuit breaker where the opening and closing times can be controlled either from an external Simulink signal (external control mode), or from an internal control timer (internal control mode).

The Three-Phase Fault block uses three Breaker blocks that can be individually switched on and off to program phase-to-phase faults, phase-to-ground faults, or a combination of phase-to-phase and ground faults.

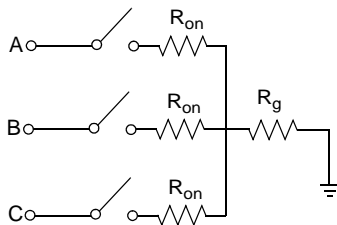

The ground resistance R_g is automatically set to 10^6 ohms when the ground fault option is not programmed. For example, to program a fault between the phases A and B you need to select the **Phase A Fault** and **Phase B Fault** block parameters only. To program a fault between the phase A and the ground, you need to select the **Phase A Fault** and **Ground Fault** parameters and specify a small value for the ground resistance.

If the Three-Phase Fault block is set in external control mode, a control input appears in the block icon. The control signal connected to the fourth input must be either 0 or 1, 0 to open the breakers, 1 to close them. If the Three-Phase Fault block is set in internal control mode, the switching times and status are specified in the dialog box of the block.

Series R_p - C_p snubber circuits are included in the model. They can be optionally connected to the fault breakers. If the Three-Phase Fault block is in series with an inductive circuit, an open circuit or a current source, you must use the snubbers.

Dialog Box and Parameters

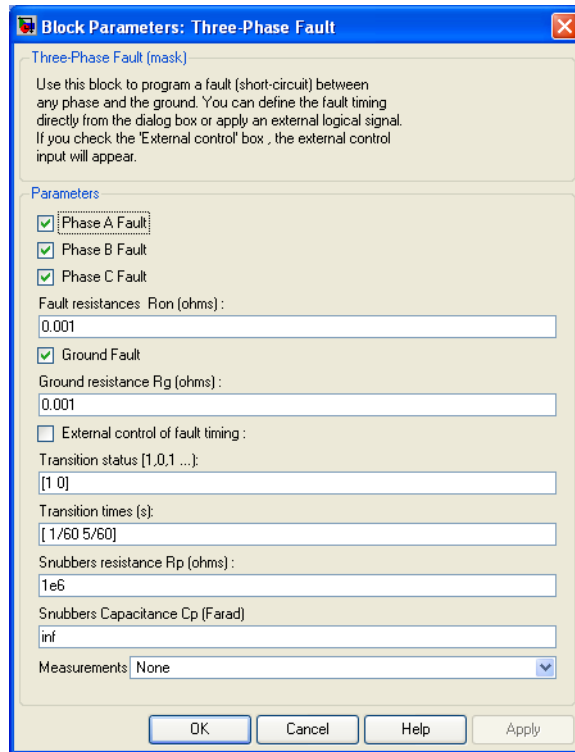

Phase A Fault

If selected, the fault switching of phase A is activated. If not selected, the breaker of phase A stays in its initial status. The initial status of the phase A breaker corresponds to the complement of the first value specified in the vector of **Transition status**. The initial status of the fault breaker is usually 0 (open). However, it is possible to start a simulation in steady state with the fault initially applied on the system. For example, if the first value in the **Transition status** vector is 0, the phase A breaker is initially closed. It opens at the first time specified in the **Transition time(s)** vector.

Phase B Fault

If selected, the fault switching of phase B is activated. If not selected, the breaker of phase B stays in its initial status. The initial status of the phase

Three-Phase Fault

B breaker corresponds to the complement of the first value specified in the vector of **Transition status**.

Phase C Fault

If selected, the fault switching of phase C is activated. If not selected, the breaker of phase C stays in its initial status. The initial status of the phase C breaker corresponds to the complement of the first value specified in the vector of **Transition status**.

Fault resistances Ron

The internal resistance, in ohms (Ω), of the phase fault breakers. The **Fault resistances Ron** parameter cannot be set to 0.

Ground Fault

If selected, the fault switching to the ground is activated. A fault to the ground can be programmed for the activated phases. For example, if the **Phase C Fault** and **Ground Fault** parameters are selected, a fault to the ground is applied to the phase C. The ground resistance is set internally to 1e6 ohms when the **Ground Fault** parameter is not selected.

Ground resistance Rg

The **Ground resistance Rg (ohms)** parameter is not visible if the **Ground Fault** parameter is not selected. The ground resistance, in ohms (Ω). The **Ground resistance Rg (ohms)** parameter cannot be set to 0.

External control of fault timing

If selected, adds a fourth input port to the Three-Phase Fault block for an external control of the switching times of the fault breakers. The switching times are defined by a Simulink signal (0 or 1) connected to the fourth input port of the block.

Transition status

Specify the vector of switching status when using the Three-Phase Breaker block in internal control mode. The selected fault breakers open (0) or close (1) at each transition time according to the **Transition status** parameter values.

The initial status of the breakers corresponds to the complement of the first value specified in the vector of switching status.

Transition times(s)

Specify the vector of switching times when using the Three-Phase Breaker block in internal control mode. At each transition time the selected fault breakers opens or closes depending to the initial state. The **Transition times (s)** parameter is not visible in the dialog box if the **External control of switching times** parameter is selected.

Snubbers resistance Rp

The snubber resistances, in ohms (Ω). Set the **Snubbers resistance Rp** parameter to `inf` to eliminate the snubbers from the model.

Snubbers capacitance Cp

The snubber capacitances, in farads (F). Set the **Snubbers capacitance Cp** parameter to 0 to eliminate the snubbers, or to `inf` to get resistive snubbers.

Measurements

Select `Fault voltages` to measure the voltage across the three internal fault breaker terminals.

Select `Fault currents` to measure the current flowing through the three internal breakers. If the snubber devices are connected, the measured currents are the ones flowing through the breakers contacts only.

Select `Fault voltages` and `currents` to measure the breaker voltages and the breaker currents.

Place a Multimeter block in your model to display the selected measurements during the simulation. In the **Available Measurements** list

Three-Phase Fault

box of the Multimeter block, the measurements are identified by a label followed by the block name and the phase:

Measurement	Label
Fault voltages	Ub <block name> /Fault A: Ub <block name> /Fault B: Ub <block name> /Fault C.
Fault currents	Ib <block name> /Fault A: Ib <block name> /Fault B: Ib <block name> /Fault C.

Inputs and Outputs

The three fault breakers are connected in wye between terminals A, B and C and the internal ground resistor. If the Three-Phase Fault block is set to external control mode, a Simulink input is added to the block to control the opening and closing of the three internal breakers.

Example

See the power_3phseriescomp demo for a circuit using the Three-Phase Fault block.

See Also

Breaker, Multimeter, and Three-Phase Breaker

Three-Phase Harmonic Filter

Purpose Implement four types of three-phase harmonic filters using RLC components

Library Elements

Description

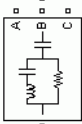
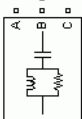
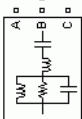
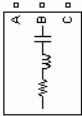

Three-phase harmonic filters are shunt elements that are used in power systems for decreasing voltage distortion and for power factor correction. Nonlinear elements such as power electronic converters generate harmonic currents or harmonic voltages, which are injected into power system. The resulting distorted currents flowing through system impedance produce harmonic voltage distortion. Harmonic filters reduce distortion by diverting harmonic currents in low impedance paths. Harmonic filters are designed to be capacitive at fundamental frequency, so that they are also used for producing reactive power required by converters and for power factor correction.

In order to achieve an acceptable distortion, several banks of filters of different types are usually connected in parallel. The most commonly used filter types are

- Band-pass filters, which are used to filter lowest order harmonics such as 5th, 7th, 11th, 13th, etc. Band-pass filters can be tuned at a single frequency (single-tuned filter) or at two frequencies (double-tuned filter).
- High-pass filters, which are used to filter high-order harmonics and cover a wide range of frequencies. A special type of high-pass filter, the C-type high-pass filter, is used to provide reactive power and avoid parallel resonances. It also allows filtering low order harmonics (such as 3rd), while keeping zero losses at fundamental frequency.

The Three-Phase Harmonic Filter is built of RLC elements. The resistance, inductance, and capacitance values are determined from the filter type and from the following parameters:

- Reactive power at nominal voltage
- Tuning frequencies
- Quality factor. The quality factor is a measure of the sharpness of the tuning frequency. It is determined by the resistance value.

Three-Phase Harmonic Filter

The four types of filters that can be modeled with the Three-Phase Harmonic Filter block are shown below:

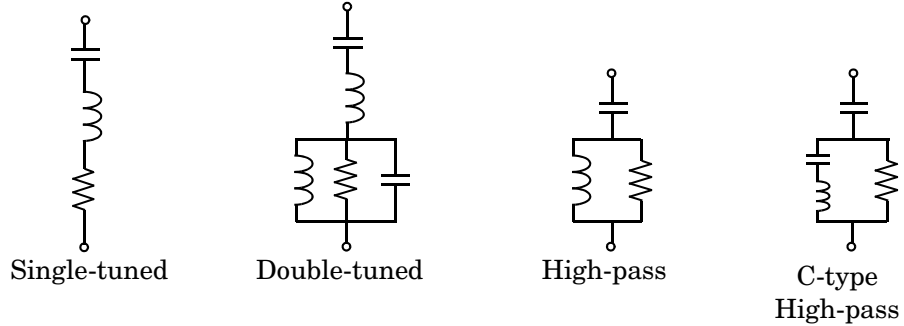

The simplest filter type is the single-tuned filter. The following figure gives the definition of the quality factor Q and practical formulae for computing the reactive power Q_C and losses (active power P). The quality factor Q of the filter is the quality factor of the reactance at the tuning frequency $Q = (n \cdot X_L) / R$. The quality factor determines the bandwidth B , which is a measure of the sharpness of the tuning frequency as shown in the figure.

Three-Phase Harmonic Filter

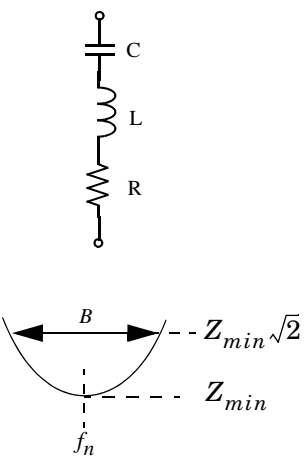

Tuned harmonic order $n = \frac{f_n}{f_1} = \sqrt{\frac{X_C}{X_L}}$

Quality factor $Q = \frac{n \cdot X_L}{R} = \frac{X_C}{n \cdot R}$

Bandwidth $B = \frac{f_n}{Q}$

Reactive power at f_1 $Q_C = \frac{V^2}{X_C} \cdot \frac{n^2}{(n^2 - 1)}$

Active power at f_1 (losses) $P \cong Q_C \cdot \frac{n}{n^2 - 1} \cdot \frac{1}{Q}$

where:

- f_1 = fundamental frequency
- $\omega = 2\pi f_1$ = angular frequency
- f_n = tuning frequency
- n = harmonic order f_n/f_1
- V = nominal line-line voltage
- X_L = inductor reactance at fundamental frequency = $L\omega$
- X_C = capacitor reactance at fundamental frequency = $1/C\omega$

The double-tuned filter performs the same function as two single-tuned filters although it has certain advantages: its losses are much lower and the impedance magnitude at the frequency of the parallel resonance that arises between the two tuning frequencies is lower.

The double-tuned filter consists of a series LC circuit and a parallel RLC circuit. If f_1 and f_2 are the two tuning frequencies, both the series circuit and the parallel circuit are tuned to approximately the mean geometric frequency $f_m = \sqrt{f_1 f_2}$.

The quality factor Q of the double-tuned filter is defined as the quality factor of the parallel L, R elements at the mean frequency f_m : $Q = \frac{R}{L \times 2\pi f_m}$.

Three-Phase Harmonic Filter

The high-pass filter is a single-tuned filter where the L and R elements are connected in parallel instead of series. This connection results in a wide-band filter having an impedance at high frequencies limited by the resistance R.

The quality factor of the high-pass filter is the quality factor of the parallel RL

circuit at the tuning frequency: $Q = \frac{R}{L \times 2\pi f_n}$.

The C-type high-pass filter is a variation of the high-pass filter, where the inductance L is replaced with a series LC circuit tuned at the fundamental frequency. At fundamental frequency, the resistance is, therefore, bypassed by the resonant LC circuit and losses are null.

The quality factor of the C-type filter is still given by the ratio: $Q = \frac{R}{L \times 2\pi f_n}$.

The following figures give R, L, C values and typical impedance versus frequency curves obtained for the four types of filters applied on a 60 Hz network. Each filter is rated 315 kV, 49 Mvar.

Three-Phase Harmonic Filter

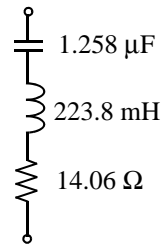

$Q_c = 49$ Mvar
 $P = 340$ kW

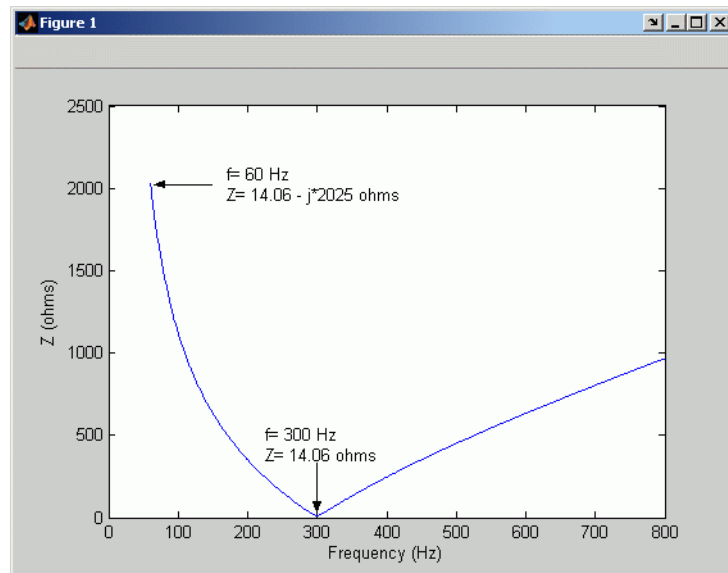

Single-Tuned, 315 kV, 49 Mvar, 5th Harmonic Filter; $Q = 30$

Three-Phase Harmonic Filter

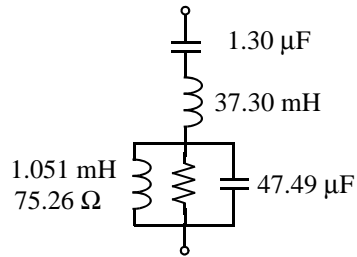

$Q_c = 49$ Mvar

$P = 50$ W

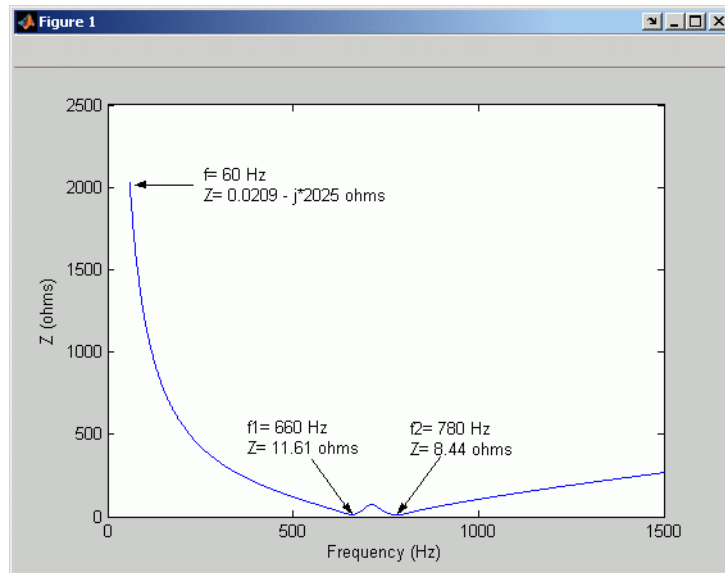

Double-Tuned, 315 kV, 49 Mvar, 11th and 13th Harmonics Filter; $Q = 16$

Three-Phase Harmonic Filter

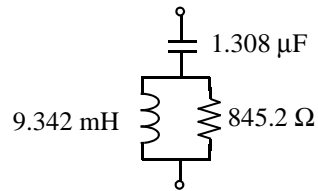

$Q_c = 49$ Mvar
 $P = 355$ W

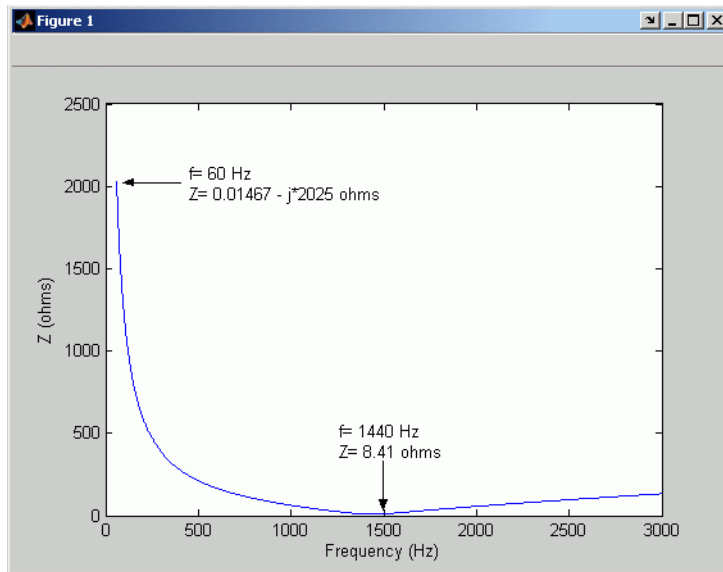

High-Pass, 315 kV, 49 Mvar, 24th Harmonic Filter; $Q = 10$

Three-Phase Harmonic Filter

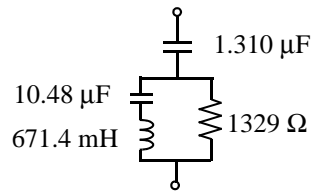

$$Q_c = 49 \text{ Mvar}$$
$$P = 0$$

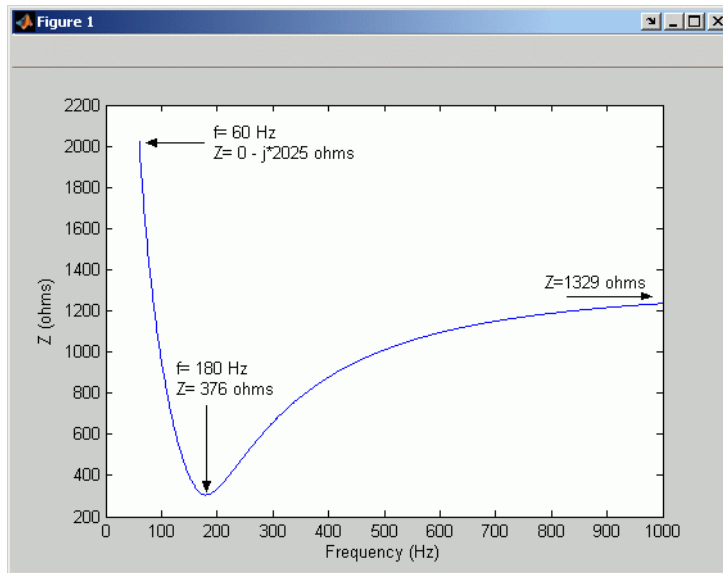

C-Type High-Pass, 315 kV, 49 Mvar, 3rd Harmonic Filter; $Q = 1.75$

Dialog Box and Parameters

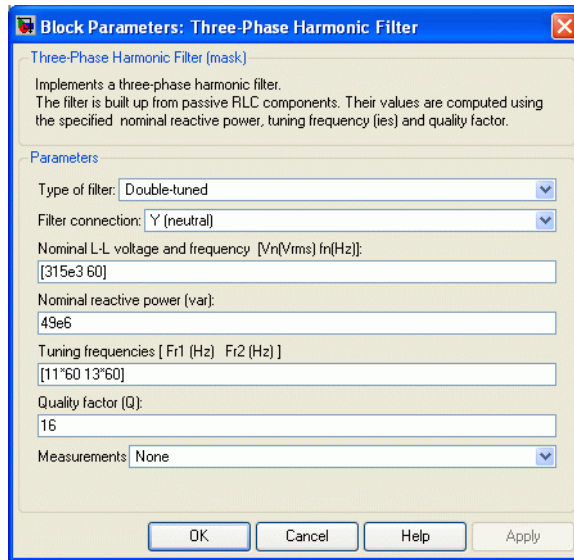

Type of filter

Select one of the four filter types: Single-tuned, Double-tuned, High-pass or C-type high-pass.

Filter connection

Select the connection of the three filter branches.

Y (grounded)	Neutral is grounded.
Y (floating)	Neutral is not accessible.
Y (neutral)	Neutral is made accessible through a fourth connector.
Delta	Three phases connected in delta.

Nominal L-L voltage and frequency

The nominal phase-to-phase voltage of the filter, in volts RMS (V_{rms}) and the nominal frequency, in hertz (Hz).

Three-Phase Harmonic Filter

Nominal reactive power

The three-phase capacitive reactive power Q_C , in vars. Specify a positive value.

Tuning frequency or Tuning frequencies

The tuning frequency of the single frequency filter (single-tuned, high-pass or C-type high-pass), or the two frequencies of the double-tuned filter, in hertz (Hz).

Quality factor (Q)

The quality factor Q of the filter defined as explained in the above Description section. Dimensionless positive number.

Measurements

Select **Branch voltages** to measure the three voltages across each phase of the Three-Phase Harmonic Filter block terminals. For a Y connection, these voltages are the phase-to-ground or phase-to-neutral voltages. For a delta connection, these voltages are the phase-to-phase voltages.

Select **Branch currents** to measure the three currents flowing through each phase of the filter. For a delta connection, these currents are the currents flowing in each branch of the delta.

Select **Branch voltages and currents** to measure the three voltages and the three currents of the Three-Phase Harmonic Filter block.

Place a Multimeter block in your model to display the selected measurements during the simulation. In the **Available Measurements** list box of the Multimeter block, the measurements are identified by a label followed by the block name.

Measurement		Label
Branch voltages	Y(grounded): U_{ag}, U_{bg}, U_{cg}	$U_{ag}:$, $U_{bg}:$, $U_{cg}:$
	Y(floating): U_{an}, U_{bn}, U_{cn}	$U_{an}:$, $U_{bn}:$, $U_{cn}:$
	Y(neutral): U_{an}, U_{bn}, U_{cn}	$U_{an}:$, $U_{bn}:$, $U_{cn}:$
	Delta: U_{ab}, U_{bc}, U_{ca}	$U_{ab}:$, $U_{bc}:$, $U_{ca}:$
Branch currents	Y(grounded): I_a, I_b, I_c	$I_{ag}:$, $I_{bg}:$, $I_{cg}:$

Three-Phase Harmonic Filter

Measurement		Label
	Y(floating): Ia, Ib, Ic	Ian: , Ibn: , Icn:
	Y(neutral): Ia, Ib, Ic	Ian: , Ibn: , Icn:
	Delta: Iab, Ibc, Ica	Iab: , Ibc: , Ica:

Example

The power_harmonicfilter demo illustrates the use of the Three-Phase Harmonic Filter block to filter harmonic currents generated by a 12-pulse, 1000 MW, AC/DC converter in a 500 kV, 60 Hz system. The filter set is made of the following four components providing a total of 600 Mvar:

- One 150 Mvar C-type high-pass filter tuned to the 3rd harmonic (F1)
- One 150 Mvar double-tuned filter tuned to the 11/13th (F2)
- One 150 Mvar high-pass filter tuned to the 24th (F3)
- One 150 Mvar capacitor bank

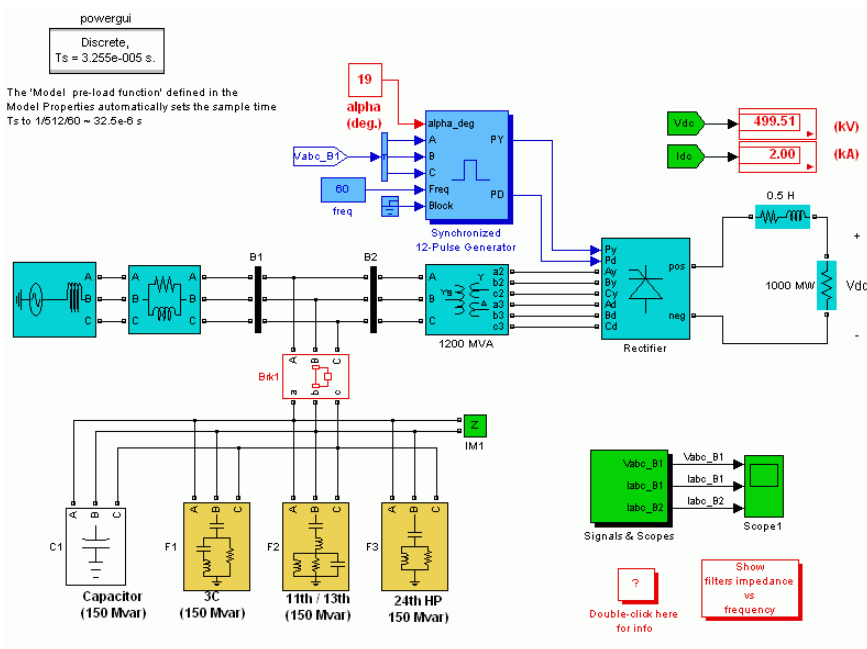

Three-Phase Harmonic Filter

Time-domain simulation

Run the simulation with an alpha firing angle of 19 degrees. You should get a DC voltage level of 500 kV. Now, look inside Scope1. Compare the currents flowing into Bus B1 (I_{abc_B1} , axis 2) with those flowing into Bus B2 (I_{abc_B2} , axis 3). You can see that the harmonic filters almost eliminate the harmonics generated by the converter. If you use the FFT tool of the Powergui, you will find that the harmonic filters reduce the THD of the current injected in the system from 9% to 0.7%.

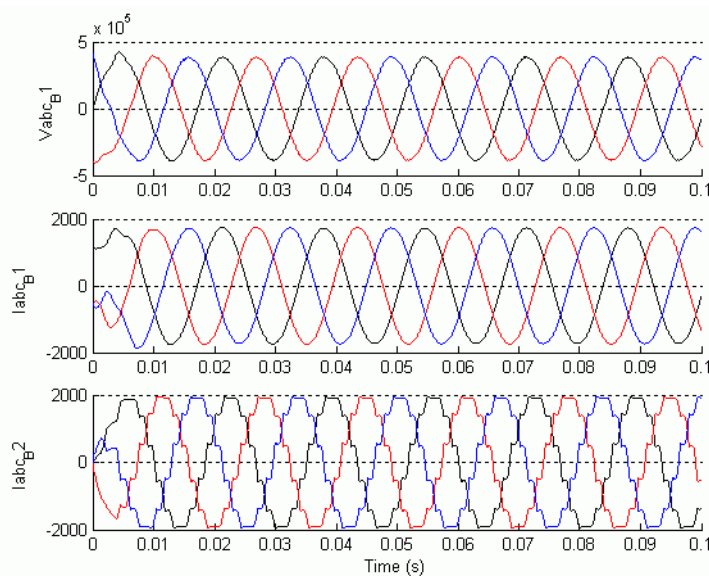

Frequency-Domain Response

You will now plot the impedance vs. frequency of the harmonic filters:

- 1 Disconnect the filters from the AC bus. To do so, double-click on the breaker Brk1, select **open** for initial status of breakers, and click **OK**.
- 2 Open the Powergui and select **Impedance vs Frequency Measurement**.
- 3 Click the **Display/Save** button. SimPowerSystems computes and displays the filter's frequency response.

Three-Phase Harmonic Filter

- 4 Double-click the block Show filters impedance vs frequency. A second figure appears, showing the precomputed filters frequency response. The impedance data of the two figures should be identical to the one shown below.

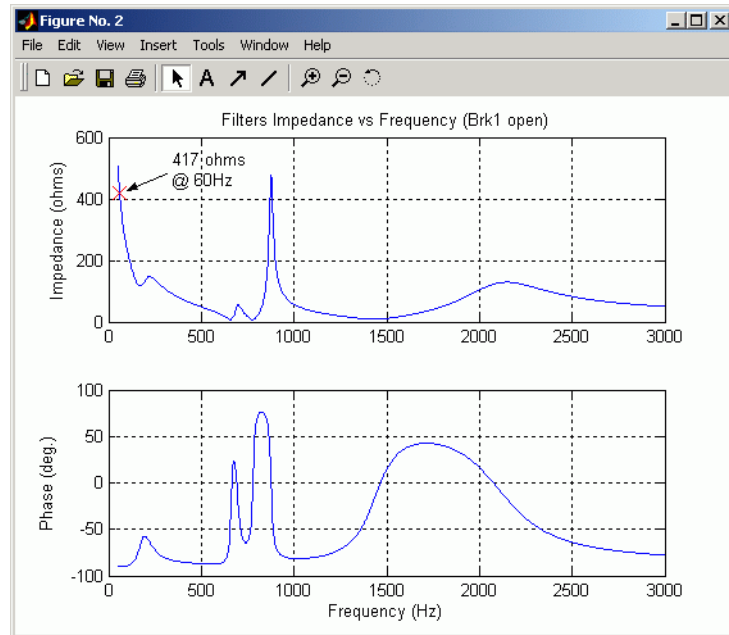

If you zoom the figure (using the **Tool** menu), you should find an impedance of 417 ohms capacitive (-90deg.) at 60 Hz. This value confirms that the total reactive power of the filters at 60 Hz is

$$Q_c = \frac{V^2}{X_c} = \frac{(500 \times 10^3)^2}{417} = 600 \text{ Mvar}$$

Three-Phase Mutual Inductance Z1-Z0

Purpose Implement a three-phase impedance with mutual coupling among phases

Library Elements

Description

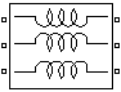

The Three-Phase Mutual Inductance Z1-Z0 block implements a three-phase balanced inductive and resistive impedance with mutual coupling between phases. This block performs the same function as the three-winding Mutual Inductance block. For three-phase balanced power systems, it provides a more convenient way of entering system parameters in terms of positive- and zero-sequence resistances and inductances than the self- and mutual resistances and inductances.

Dialog Box and Parameters

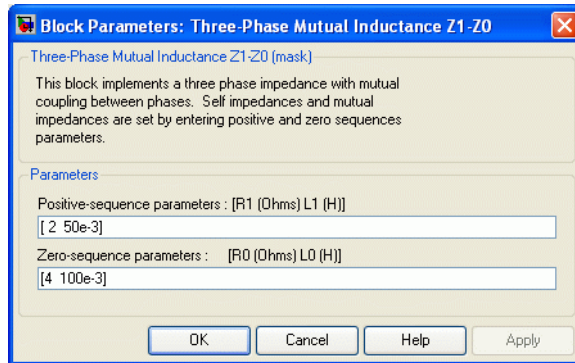

Positive-sequence parameters

The positive-sequence resistance $R1$, in ohms (Ω), and the positive-sequence inductance $L1$, in henries (H).

Zero-sequence parameters

The zero-sequence resistance $R0$, in ohms (Ω), and the zero-sequence inductance $L0$, in henries (H).

Example

The power_3phmutseq10 demo illustrates the use of the Three-Phase Mutual Inductance Z1-Z0 block to build a three-phase inductive source with different values for the positive-sequence impedance $Z1$ and the zero-sequence impedance $Z0$. The programmed impedance values are $Z1 = 1+j1 \Omega$ and $Z0 = 2+j2 \Omega$. The Three-Phase Programmable Voltage Source block is used to

Three-Phase Mutual Inductance Z1-Z0

generate a 1-volt, 0-degree, positive-sequence internal voltage. At $t = 0.1$ s, a 1-volt, 0-degree, zero-sequence voltage is added to the positive-sequence voltage. The three source terminals are short-circuited to ground and the resulting positive-, negative-, and zero-sequence currents are measured using the Discrete 3-Phase Sequence Analyzer block.

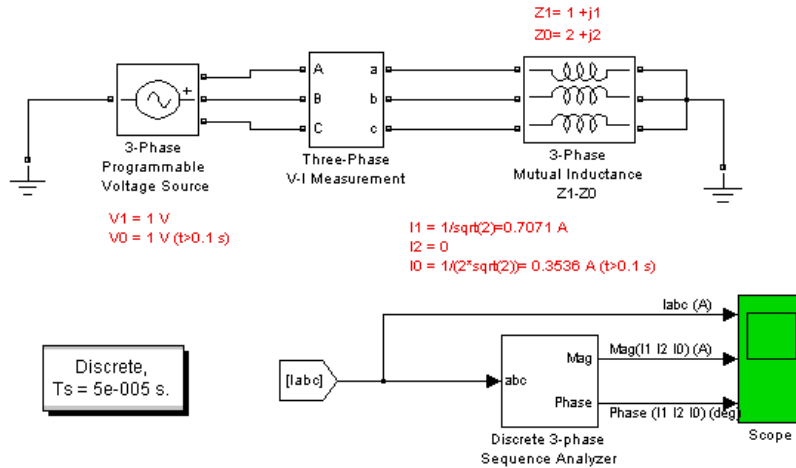

The current waveforms and their sequence components (magnitude and phase) are displayed on the Scope block. The resulting waveforms are shown on the following figure.

Three-Phase Mutual Inductance Z1-Z0

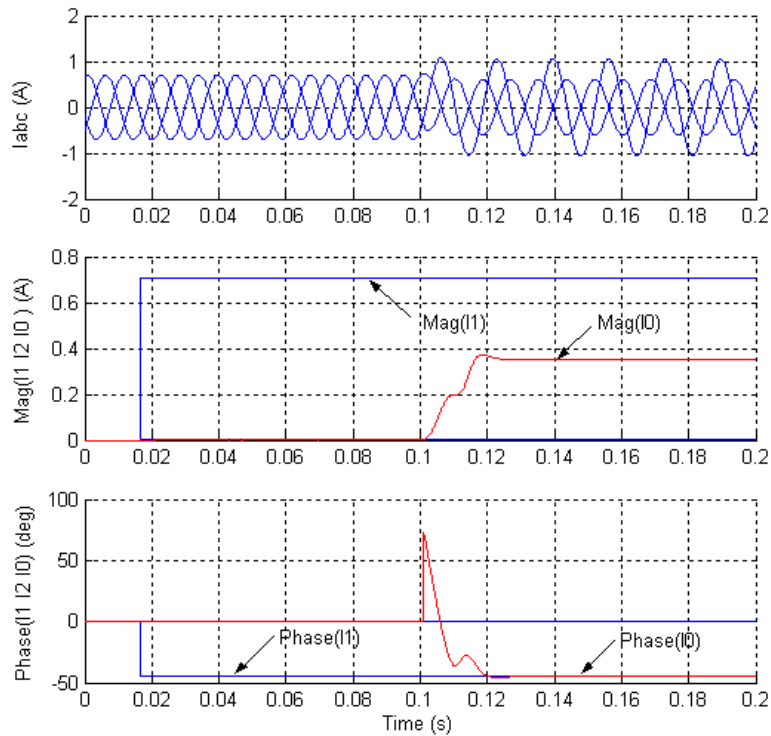

The polar impedance values are $Z1 = \sqrt{2} \angle 45^\circ \Omega$ and $Z0 = 2\sqrt{2} \angle 45^\circ \Omega$

Therefore, the positive- and zero-sequence currents displayed on the scope are

$$I1 = V1/Z1 = 1/(\sqrt{2} \angle 45^\circ) = 0.7071 \text{ A} \angle -45^\circ$$

$$I0 = V0/Z0 = 1/(2\sqrt{2} \angle 45^\circ) = 0.3536 \text{ A} \angle -45^\circ$$

The transients observed on the magnitude and the phase angle of the zero-sequence current when the zero-sequence voltage is added (at $t = 0.1$ s) are due to the Fourier measurement technique used by the Discrete 3-Phase Sequence Analyzer block. As the Fourier analysis uses a running average window of one cycle, it takes one cycle for the magnitude and phase to stabilize.

See Also

Mutual Inductance

Three-Phase OLTC Phase-Shifting Transformer Delta-Hexagonal (Phasor Type)

Purpose

Implements a phasor model of a three-phase OLTC phase-shifting transformer using the delta hexagonal connection

Library

Flexible AC Transmission Systems (FACTS)/Transformers

Description

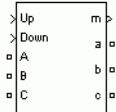

This block is used to model a phase-shifting transformer using on-load tap changers (OLTC) for introducing a phase shift between three-phase voltages at two buses in a transmission system. Controlling phase-shift on a transmission system will affect primarily flow of active power. Although the phase-shifting transformer does not provide as much flexibility and speed as power-electronics based FACTS, it can be considered as a basic power flow controller. This is why it has been included in the facts library. The dynamic performance of the phase-shifting transformer can be enhanced by using a thyristor-based tap changer instead of a mechanical tap changer. As this model is a phasor model which does not implement the details of current transfer from one tap to the next tap, you can use it to model a thyristor-based phase-shifter. You can also use this block together with the Three-phase OLTC Regulating Transformer (Phasor Type) block for building phasor models of more complex transformer-based FACTS topologies.

The delta hexagonal connection consists of three pairs of windings interconnected in a hexagonal configuration as shown on the figure below.

Three-Phase OLTC Phase-Shifting Transformer Delta-Hexagonal (Phasor Type)

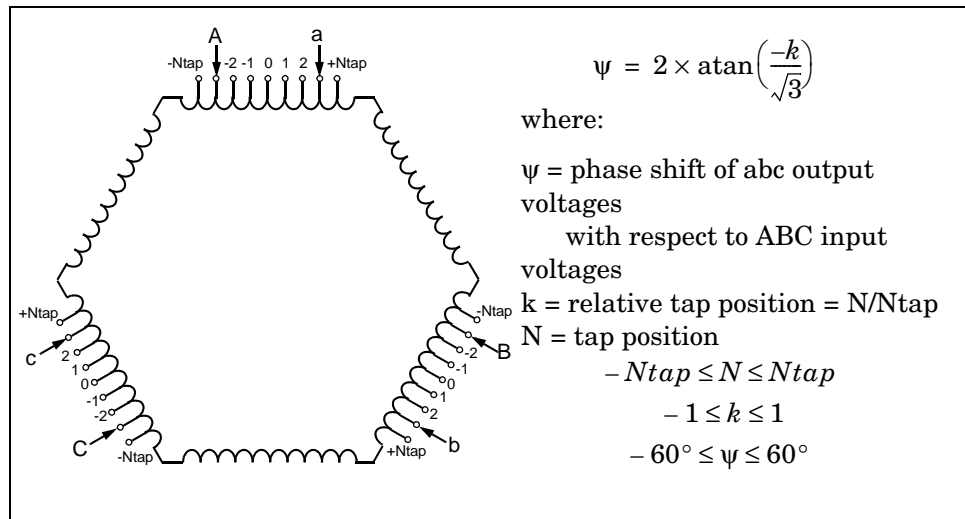

Delta-Hexagonal Phase-Shifting Transformer Connections

Each phase consists of two coupled windings drawn in parallel on the figure: one tapped winding with two OLTCs and one winding without taps. All windings have the same number of turns. The two OLTCs vary phase shift by moving transformer input terminals (A, B, C) and outputs terminals (a, b, c) symmetrically with respect to center tap 0. This delta hexagonal connection has the advantage of keeping a 1:1 voltage ratio while the phase shift is varied.

When the two OLTCs move taps from the center position (0) to the winding end (position N_{tap}), the phase shift between inputs (ABC) and outputs (abc) varies from 0 to 60 degrees. When ABC are at position $-N_{\text{tap}}$ and abc are at position $+N_{\text{tap}}$, the output voltages abc are lagging input voltages ABC by 60 degrees. On the other end, when ABC are at position $+N_{\text{tap}}$ and abc are at position $-N_{\text{tap}}$, the output voltages abc are leading input voltages ABC by 60 degrees. For intermediate positions the phase shift ψ is given by the equation on the figure. This equation assumes that all tap are evenly spaced.

For example, if each half tapped winding consists of 10 taps (total of 21 taps/winding including center tap 0) and if ABC and abc terminals are respectively at tap -7 and tap +7, then, $k=7/10=0.7$

Therefore, abc voltages are lagging ABC voltages by 44 degrees.

Three-Phase OLTC Phase-Shifting Transformer Delta-Hexagonal (Phasor Type)

The phase angle varies almost linearly as function of tap position as shown on the figure below.

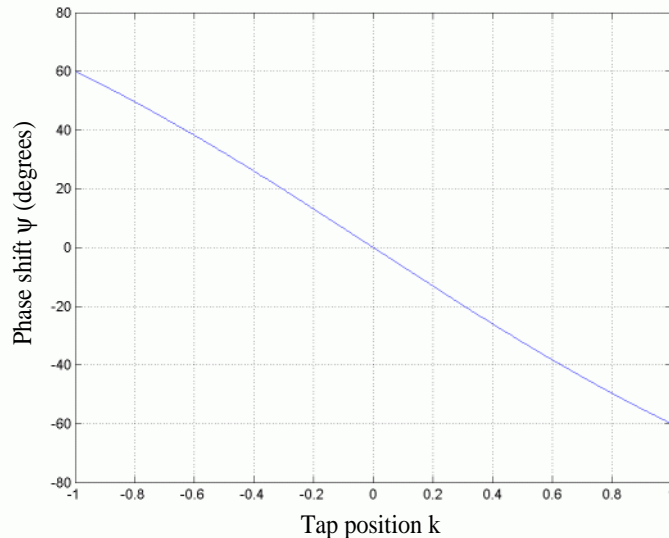

Variation of phase shift as function of tap position

You control tap positions, and therefore phase shift, by sending pulses to one of the two block inputs labeled Up and Down. Applying a pulse to the Up (or Down) input will move the tap position upward (or downward) when the signal is changing from 0 to 1.

Mechanical tap changers are relatively slow devices. The time required to move from one tap position to the next one is usually comprised between 3 and 10 seconds. You specify this mechanical time delay in the block menu.

Note OLTCs use additional switches and resistors (or inductors) to transfer current from the outgoing tap to the ongoing tap without interrupting load current. During the transfer, taps are temporarily short circuited through resistors or inductors. The transfer time (typically from 40 ms to 60 ms) is fast as compared to the tap selection process (3s to 10 s). As this block implements a phasor model for study of transient stability of power systems in the range

Three-Phase OLTC Phase-Shifting Transformer Delta-Hexagonal (Phasor Type)

of seconds to minutes, the tap transfer process is not modelled and an instantaneous tap transfer is assumed. A detailed delta-hexagonal phase-shifting transformer model is provided in the power_PSTdeltahex demo.

Dialog Box and Parameters

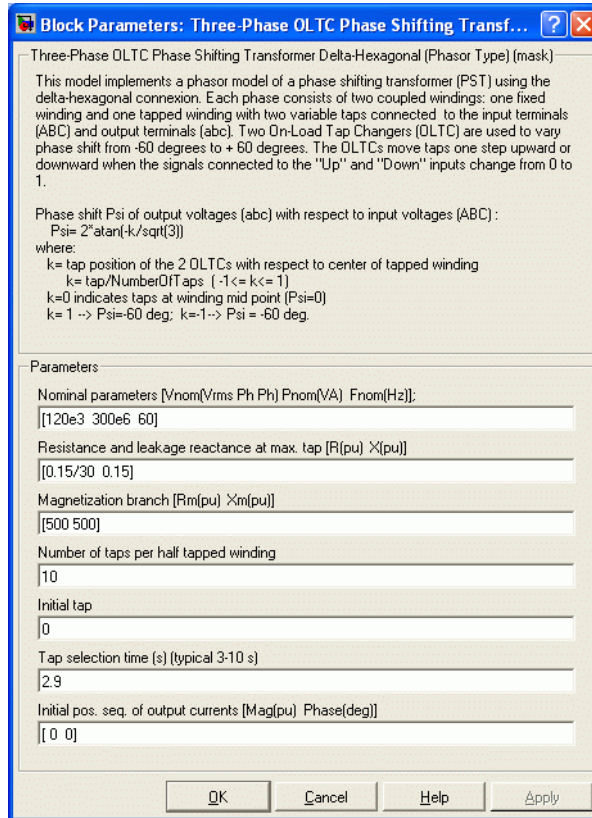

Nominal parameters [Vnom Pnom Fnom]

The nominal line to line voltage, in volts rms, the three-phase nominal power, in VA and the nominal frequency, in hertz.

Three-Phase OLTC Phase-Shifting Transformer Delta-Hexagonal (Phasor Type)

Resistance and leakage reactance at max. tap [R X]

The transformer short circuit impedance due to winding resistances and leakage reactances, at maximum phase shift (input and output taps at -Ntap and +Ntap positions). Specify resistance and reactance, in p.u.

The transformer positive-sequence impedance Z_1 , in p.u. and zero-sequence Z_0 , in p.u., vary with relative tap position k as follows:

$$Z_1 = (R + jX) \times \frac{|k| (-3k^2 + 2|k| + 9)}{2(k^2 + 3)}$$
$$Z_0 = \frac{R_m \times jX_m}{R_m + jX_m} \times k^2$$

where: R , X are the transformer resistance and reactance defined in the parameter **Resistance and leakage reactance at max. tap** ($k=1$ or $k=-1$) and **R_m , X_m are the transformer magnetizing** resistance and reactance defined in the **Magnetizing branch** parameter described below.

Note that these impedances keep the same value for positive and negative values of k . For $k=0$, impedances are zero because the transformer input terminals are short-circuited with output terminals.

Magnetizing branch [Rm Xm]

The resistance, in p.u. and the reactance, in p.u. of the parallel R_m , X_m branch modelling respectively iron losses and reactive magnetizing currents. Saturation is not modelled.

Number of taps per half winding (Ntap)

The number of taps per half winding. The total number of taps per winding, including center tap 0, is therefore $2*Ntap+1$.

Initial tap

Specify an integer (Tapinit) corresponding the initial tap position of output terminals abc. The initial tap position of input terminals ABC is therefore -Tapinit.

Tap selection time

The mechanical time delay, in seconds, required for the OLTCs to move the taps by one position. Typical values are in the 3s-10s range.

Three-Phase OLTC Phase-Shifting Transformer Delta-Hexagonal (Phasor Type)

Initial pos. seq. output currents [Mag Phase]

The initial value of the positive-sequence current phasor (Magnitude in p.u. and Phase in degrees) flowing out of terminals abc. If you know the initial value of currents you may specify it in order to start simulation in steady state. If you don't know these values, you can leave [0 0]. The system will reach steady-state after a short transient.

Inputs and Outputs

A B C

The three transformer input terminals

a b c

The three transformer output terminals

Up

Simulink input for controlling tap position. Applying a pulse to this input will initiate upward tap changing when the pulse is changing from 0 to 1.

Down

Simulink input for controlling tap position. Applying a pulse to this input will initiate downward tap changing when the pulse is changing from 0 to 1.

m

Simulink output vector containing 17 internal signals. These signals are either complex signals (voltage phasors, current phasors or impedances) or control signals. They can be individually accessed by using the Bus Selector block. They are, in order:

Signal	Signal Group	Signal Names	Definition
1-3	VABC (cmplx)	VA (pu) VB (pu) VC (pu)	Phasor voltages (phase to ground) at the transformer input terminals A, B, C (p.u.)
4-6	Vabc (cmplx)	Va (pu) Vb (pu) Vc (pu)	Phasor voltages (phase to ground) at the transformer output terminals a, b, c (p.u.)

Three-Phase OLTC Phase-Shifting Transformer Delta-Hexagonal (Phasor Type)

Signal	Signal Group	Signal Names	Definition (Continued)
7-9	IABC (cmplx)	IA (pu) IB (pu) IC (pu)	Phasor currents flowing into the input terminals A, B, C
10-1 2	Iabc (cmplx)	Ia (pu) Ib (pu) Ic (pu)	Phasor currents flowing out of the output terminals a, b, c
13-1 4	Z (cmplx)	Z1 (pu) Z0 (pu)	Positive- and zero-sequence complex impedances (R+jX)
15	Psi (degrees)	Psi (degrees)	Phase shift of abc output voltages with respect to ABC input voltages
16	Tap	Tap	Tap position
17	Ready	Ready	Logical signal generated by the tap changer controller. The Ready signal becomes (1) after the tap selection has been completed, thus enabling a new tap change. The Up and Down pulses to the OLTC are blocked as long as the Ready signal is (0).

Example

See the power_PSTdeltahex demo which illustrates the use of the Three-Phase OLTC Phase Shifting Transformer Delta-Hexagonal (Phasor Type) block to control power transfer between two equivalent sources in a 120 kV transmission. The phasor model is compared with a detailed model of phase shifting transformer. Look under the masked blocks to see how both models are implemented. The detailed model uses switches and three Multi-Winding Transformer blocks, whereas the phasor model uses current sources.

See Also

Three-Phase OLTC Regulating Transformer (Phasor Type)

Three-Phase OLTC Regulating Transformer (Phasor Type)

Purpose Implements a phasor model of a three-phase OLTC regulating transformer

Library Flexible AC Transmission Systems (FACTS)/Transformers

Description

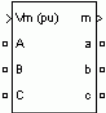

This block is used to model a three-phase two-winding transformer or autotransformer using a on-load tap changer (OLTC) for regulating voltage on a transmission or distribution system. Controlling voltage on a transmission system will affect primarily flow of reactive power, which, in turn, will affect the power transfer limits. Although the regulating transformer does not provide as much flexibility and speed as power-electronics based FACTS, it can be considered as a basic power flow controller. This is why it has been included in the facts library. The dynamic performance of the regulating transformer can be enhanced by using a thyristor-based tap changer instead of a mechanical tap changer. As this model is a phasor model which does not implement the details of current commutation from one tap to the next tap, you can use it to model a thyristor-based tap changer and implement your own control system by selecting **External control of OLTC** in the block menu. You can also use this block together with the Three-phase OLTC Phase-Shifting Transformer Delta-Hexagonal (Phasor Type) block for building phasor models of more complex transformer-based FACTS topologies.

Three-Phase OLTC Regulating Transformer (Phasor Type)

The figure below shows one phase of the three-phase regulating transformer. Each phase consists of main windings 1 and 2 and of a tapped regulation winding.

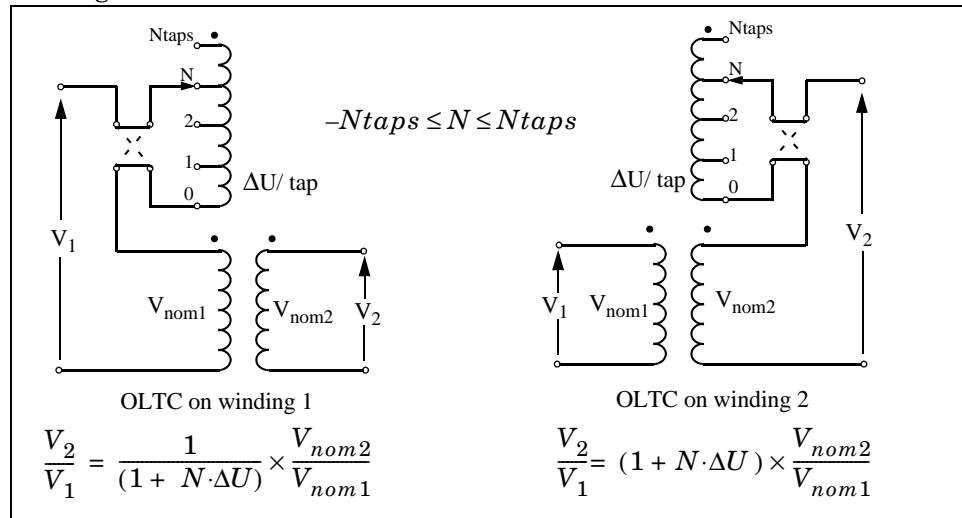

One Phase of the Regulating Transformer

Voltage regulation is performed by varying the transformer ratio V_2/V_1 by means of the OLTC. The OLTC can be connected either on winding 1 (left diagram) or on winding 2 (right diagram). The OLTC can select any tap from position 0 (no voltage correction) to maximum tap (position N_{tap}) yielding maximum voltage correction. The OLTC is also equipped with a reversing switch which allows connecting the regulation winding either in additive or subtractive polarity. The factor multiplying V_{nom2}/V_{nom1} on the figure is the voltage correction factor. It is given by:

$$\begin{aligned} & 1/(1 + N \cdot \Delta U) \quad \text{for OLTC on winding 1} \\ & (1 + N \cdot \Delta U) \quad \text{for OLTC on winding 2} \end{aligned}$$

where : N = tap position

ΔU = voltage per tap in p.u. of nominal voltage
of winding 1 or winding 2

Negative values of N correspond to the reversing switch position shown in dashed lines (regulation winding in subtractive polarity). The transformer resistance and leakage reactance also vary with the tap position.

Three-Phase OLTC Regulating Transformer (Phasor Type)

Mechanical tap changers are relatively slow devices. The time required to move from one tap position to the next one is usually comprised between 3 and 10 seconds. You specify this mechanical time delay in the block menu.

Note OLTCs use additional switches and resistors (or inductors) to transfer current from the outgoing tap to the ongoing tap without interrupting load current. During the transfer, taps are temporarily short circuited through resistors or inductors. The transfer time (typically from 40 ms to 60 ms) is fast as compared to the tap selection process (3s to 10 s). As this block implements a phasor model for study of transient stability of power systems in the range of seconds to minutes, the tap transfer process is not modelled and an instantaneous tap transfer is assumed. A detailed regulating transformer model is provided in the `power_OLTCregtransformer` demo.

Automatic voltage control

The regulating transformer is usually associated with a control system which regulates voltage at the transformer terminals (side 1 or side 2) or at a remote bus. Such a control system is provided in the Three-Phase OLTC Regulating Transformer (Phasor Type) block. You must then connect at the `Vm` input of the block a simulink signal which is usually the magnitude of the positive-sequence voltage (in p.u.) to be controlled, but it can be any signal. The control system will adjust automatically the tap position until the measured voltage `Vm` is equal to the reference voltage `Vref` specified in the block menu.

The voltage regulator is a hysteresis type regulator. Each time a tap change is required, the regulator sends a pulse either to the `Up` or `Down` input of the Tap Changer Controller. Look under the block mask to see how these control blocks are built. The regulator will ask for a tap change if

$$\text{abs}(Vm - Vref) > DeadBand/2 \quad \text{during a time } t > Delay$$

where `Vref`, `Deadband` and `Delay` are parameters of the voltage regulator.

External control of OLTC

If you want to implement your own control system or manually control the tap position, you select **External control of OLTC**. The `Vm` input will then be

Three-Phase OLTC Regulating Transformer (Phasor Type)

replaced by two inputs labeled Up and Down. Applying a pulse to the Up or Down input will move the tap position upward or downward when the signal is changing from 0 to 1.

Dialog Box and Parameters

The transformer and OLTC parameters are grouped in two categories: Transformer parameters and OLTC and Voltage Regulator parameters. Use the **Show** listbox to select which group of parameters you want to visualize.

Transformer Parameters

Block Parameters: Three-Phase OLTC Regulating Transformor... ? X

Three-Phase OLTC Regulating Transformer (Phasor Type) (mask)

The OLTC transformer consists of two fixed windings and a third tapped winding (regulation winding) connected in series with either winding 1 or winding 2. Voltage ratio and transformer impedance vary with tap position. A +30 degrees or -30 degrees phase shift is introduced when winding 1 or winding 2 are connected in Delta.

In automatic mode, ('External control of OLTC' not checked and 'Voltage regulator' on), the signal applied at the 'Vm' input is monitored and the voltage regulator asks for a tap change if:

$$\text{abs}(V_m - V_{\text{ref}}) > \text{DeadBand}/2 \text{ during a time } t > \text{Delay.}$$

If 'External control of OLTC' is checked, the 'Vm' input is replaced with two inputs labeled 'Up' and 'Down'. When signals connected to the 'Up' and "Down" inputs change from 0 to 1, the OLTC moves tap one step upward or downward.

Parameters

Show Transformer parameters

Nominal power and frequency [Pnom (VA) Fnom(Hz)]
[47e6 60]

Winding 1 [V1(Vrms Ph Ph) R1(pu) X1(pu)]
[1120e3 0.003 0.09]

Winding 1 connection Yg

Winding 2 [V2(Vrms Ph Ph) R2(pu) X2(pu)]
[25e3 0.003 0.09]

Winding 2 connection Delta (D1)

Tapped regulation winding [R1(pu) X1(pu)]
[0.003 0.09]

Magnetization branch [Rm(pu) Xm(pu)]
[300 300]

Voltage regulator [Vref(pu) DeadBand(pu) Delay(s)]
[1.04 0.0375 1]

Initial pos. seq. output currents of winding 2: [Mag(pu) Phase(deg)]
[0.7568 -45]

OK Cancel Help Apply

Three-Phase OLTC Regulating Transformer (Phasor Type)

Nominal Power and frequency [Pnom Fnom]

The three-phase nominal power, in VA and the nominal frequency, in hertz.

Winding 1 [V1 R1 X1]

The nominal line to line voltage of winding 1, in volts rms, winding resistance in p.u., and leakage reactance, in p.u.

Winding 1 connection

The connection of the three windings 1. Select either, Y (ungrounded wye), Yg (wye grounded), Delta (D1) (Delta connection introducing a -30 degrees phase-shift) or Delta (D11) (Delta connection introducing a +30 degrees phase-shift). See the Three-Phase Transformer (Two-Windings) block documentation for an explanation of the phase shifts introduced by D1 and D11 connections. The zero-sequence impedance will vary according to the connection. Zero-sequence impedance is computed assuming that the three-phase transformer bank is built with three single-phase, two-winding units.

Winding 2 [V2 R2 X2]

The nominal line to line voltage of winding 2, in volts rms, winding resistance in p.u., and leakage reactance, in p.u.

Winding 2 connection

The connection of the three windings 2. Select either, Y (ungrounded wye), Yg (wye grounded), Delta (D1) (Delta connection introducing a -30 degrees phase-shift) or Delta (D11) (Delta connection introducing a +30 degrees phase-shift). The zero-sequence impedance will vary according to the connection.

Tapped regulation winding [Rt Xt]

The resistance and the leakage reactance of the tapped winding depend on the tap position. Enter the resistance, in p.u., and the leakage reactance, in p.u., corresponding to the maximum tap position.

Magnetizing branch [Rm Xm]

The resistance, in p.u. and the reactance, in p.u. of the parallel Rm, Xm branch modelling respectively iron losses and reactive magnetizing currents. Saturation is not modelled.

Three-Phase OLTC Regulating Transformer (Phasor Type)

Initial pos. seq. output currents of winding 2 [Mag Phase]

The initial value of the positive-sequence current phasor (Magnitude in p.u. and Phase in degrees) flowing out of winding 2. The currents flowing into winding 1 will be computed accordingly. If you know the initial value of currents you may specify it in order to start simulation in steady state. If you don't know these values, you can leave [0 0]. The system will reach steady-state after a short transient.

OLTC and Voltage Regulation Parameters

Block Parameters: Three-Phase OLTC Regulating Transformor... [?] [X]

Three-Phase OLTC Regulating Transformer (Phasor Type) (mask)

The OLTC transformer consists of two fixed windings and a third tapped winding (regulation winding) connected in series with either winding 1 or winding 2. Voltage ratio and transformer impedance vary with tap position. A +30 degrees or -30 degrees phase shift is introduced when winding 1 or winding 2 are connected in Delta.

In automatic mode, ('External control of OLTC' not checked and 'Voltage regulator' 'on'), the signal applied at the 'Vm' input is monitored and the voltage regulator asks for a tap change if:
$$\text{abs}(V_m - V_{\text{ref}}) > \text{DeadBand}/2 \text{ during a time } t > \text{Delay.}$$

If 'External control of OLTC' is checked, the 'Vm' input is replaced with two inputs labeled 'Up' and 'Down'. When signals connected to the 'Up' and 'Down' inputs change from 0 to 1, the OLTC moves tap one step upward or downward.

Parameters

Show OLTC and Voltage Regulator parameters

OLTC on: Winding 1

Voltage step DeltaU per tap (pu)
0.01875

OLTC minimum and maximum tap positions [Min Max]
[-8 +8]

Initial tap position
-4

Tap selection time (s) (typical 3-10s)
4

External control of OLTC

Voltage regulator on

Voltage regulator [Vref(pu) DeadBand(pu) Delay(s)]
[1.04 0.0375 1]

OK Cancel Help Apply

OLTC on

Select either Winding 1 or Winding 2.

Three-Phase OLTC Regulating Transformer (Phasor Type)

Voltage Step DeltaU per tap

The voltage step per tap, in p.u. of the nominal voltage of winding 1 or winding 2.

OLTC minimum and maximum tap [MinTap MaxTap]

You normally specify a negative integer corresponding to maximum tap position with the regulation winding connected in subtractive polarity, followed by a positive integer corresponding to maximum tap position with the regulation winding connected in additive polarity. These two integers specify the number of taps and their absolute values are usually the same. However, if you want to limit tap excursion, you may specify two different values.

Initial tap position

Specify an integer N corresponding to initial tap position with $MinTap \leq N \leq MaxTap$.

Tap selection time

The mechanical time delay, in seconds, required for the OLTC to move the taps by one position. Typical values are in the 3s-10s range.

External control of OLTC

The OLTC is usually controlled by the voltage regulator. Check this parameter if you want to implement your own control system or manually control the tap position. The V_m input will then be replaced by two inputs labeled Up and Down. Applying a pulse to the Up or Down input will move the tap position upward or downward when the signal is changing from 0 to 1.

Voltage regulator

This parameter is not visible when the **External control of OLTC** parameter is checked.

Select on for enabling the voltage regulator. If you select off the OLTC is frozen at the position specified by the **Initial tap position** parameter.

Voltage regulator [Vref DeadBand Delay]

This parameter is not visible when the **External control of OLTC** parameter is checked.

Three-Phase OLTC Regulating Transformer (Phasor Type)

Specify the reference voltage V_{ref} , in p.u., the dead band of the hysteresis regulator, in p.u. and the time delay, in seconds, during which the voltage error must exceed half the dead band for the OLTC to move tap position upward or downward. The dead band is normally adjusted at two times the voltage step specified in the **Voltage step DeltaU per tap** parameter.

Inputs and Outputs

A B C

The three input terminals connected windings 1.

a b c

The three output terminals connected to windings 2.

V_m

This input is visible only when the **External control of OLTC** parameter is not checked.

Connect to this input the measured voltage to be controlled by the voltage regulator. This signal is usually the magnitude, in p.u., of the positive-sequence voltage measured at the transformer terminals (side 1 or side 2) or at a remote bus.

Up

This input is visible only when the **External control of OLTC** parameter is checked.

Simulink input for controlling tap position. Applying a pulse to this input will initiate upward tap changing when the pulse is changing from 0 to 1.

Down

This input is visible only when the **External control of OLTC** parameter is checked.

Simulink input for controlling tap position. Applying a pulse to this input will initiate downward tap changing when the pulse is changing from 0 to 1.

m

Simulink output vector containing 16 internal signals. These signals are either complex signals (voltage phasors, current phasors or impedances) or

Three-Phase OLTC Regulating Transformer (Phasor Type)

control signals. They can be individually accessed by using the Bus Selector block. They are, in order:

Signal	Signal Group	Signal Names	Definition
1-3	VABC (cmplx)	VA (pu) VB (pu) VC (pu)	Phasor voltages (phase to ground) at the transformer input terminals A, B, C (p.u.)
4-6	Vabc (cmplx)	Va (pu) Vb (pu) Vc (pu)	Phasor voltages (phase to ground) at the transformer output terminals a, b, c (p.u.)
7-9	IABC (cmplx)	IA (pu) IB (pu) IC (pu)	Phasor currents flowing into the input terminals A, B, C
10-12	Iabc (cmplx)	Ia (pu) Ib (pu) Ic (pu)	Phasor currents flowing out of the output terminals a, b, c
13-14	Z (cmplx)	Z1 (pu) Z0 (pu)	Positive- and zero-sequence complex impedances (R+jX)
15	Tap	Tap	Tap position
16	Ready	Ready	Logical signal generated by the tap changer controller. This signal is used to enable voltage controller action. The Ready signal becomes (1) after the tap selection has been completed, thus enabling a new tap change. The Up and Down pulses to the OLTC are blocked as long as the Ready signal is (0).

Example

See the `power_OLTCregtransformer` demo which illustrates the use of the Three-Phase OLTC Regulator Transformer (Phasor Type) block to regulate voltage on a 25 kV distribution feeder. The phasor model is compared with a detailed model of regulating transformer. Look under the masked blocks to see

Three-Phase OLTC Regulating Transformer (Phasor Type)

how both models are implemented. The detailed model uses switches and three Multi-Winding Transformer blocks, whereas the phasor model uses current sources.

See Also

Three-Phase OLTC Phase-Shifting Transformer Delta-Hexagonal (Phasor Type)

Three-Phase Parallel RLC Branch

Purpose Implement a three-phase parallel RLC branch

Library Elements

Description

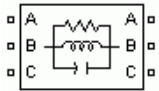

The Three-Phase Parallel RLC Branch block implements three balanced branches consisting each of a resistor, an inductor, a capacitor, or a parallel combination of these. To eliminate either the resistance, inductance, or capacitance of each branch, the R, L, and C values must be set respectively to infinity (*inf*), infinity (*inf*), and 0. Only existing elements are displayed in the block icon.

Negative values are allowed for resistance, inductance, and capacitance.

Dialog Box and Parameters

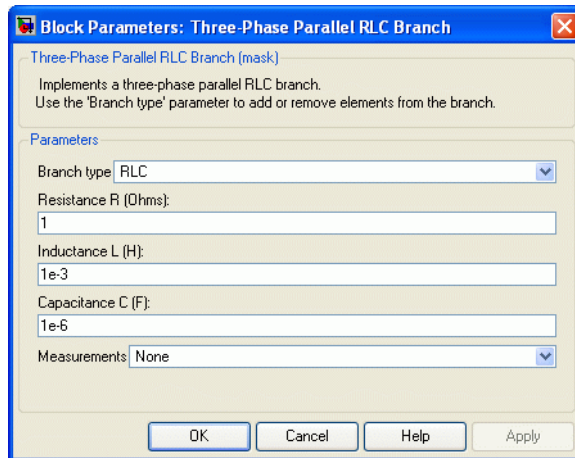

Branch type

Select the elements you want to include in the branch. The **R** letter defines the resistor, the **L** letter defines the inductor, and the **C** letter defines the capacitor.

Resistance R

The branch resistances, in ohms (Ω).

Inductance L

The branch inductances, in henries (H).

Three-Phase Parallel RLC Branch

Capacitance C

The branch capacitances, in farads (F).

Measurements

Select Branch voltages to measure the three voltages across the Three-Phase Parallel RLC Branch block terminals.

Select Branch currents to measure the three total currents (sum of R, L, C currents) flowing through the Three-Phase Parallel RLC Branch block.

Select Branch voltages and currents to measure the three voltages and the three currents of the Three-Phase Parallel RLC Branch block.

Place a Multimeter block in your model to display the selected measurements during the simulation. In the **Available Measurements** list box of the Multimeter block, the measurements are identified by a label followed by the block name.

Measurement	Label
Branch voltages of phases A, B, and C	Ua: , Ub: , Uc:
Branch currents of phases A, B, and C	Ia: , Ib: , Ic:

See Also

Multimeter, Three-Phase Parallel RLC Load, Three-Phase Series RLC Branch, Three-Phase Series RLC Load

Three-Phase Parallel RLC Load

Purpose

Implement a three-phase parallel RLC load with selectable connection

Library

Elements

Description

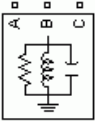

The Three-Phase Parallel RLC Load block implements a three-phase balanced load as a parallel combination of RLC elements. At the specified frequency, the load exhibits a constant impedance. The active and reactive powers absorbed by the load are proportional to the square of the applied voltage.

Only elements associated with nonzero powers are displayed in the block icon.

Dialog Box and Parameters

Configuration

The connection of the three phases. Select one of the following four connections:

Y (grounded)

Neutral is grounded.

Y (floating)

Neutral is not accessible.

Three-Phase Parallel RLC Load

Y (neutral)	Neutral is made accessible through a fourth connector.
Delta	Three phases connected in delta

The block icon is updated according to the load connection.

Nominal phase-to-phase voltage V_n

The nominal phase-to-phase voltage of the load, in volts RMS (V_{rms}).

Nominal frequency f_n

The nominal frequency, in hertz (Hz).

Active power P

The three-phase active power of the load, in watts (W).

Inductive reactive power Q_L

The three-phase inductive reactive power Q_L , in vars. Specify a positive value, or 0.

Capacitive reactive power Q_C

The three-phase capacitive reactive power Q_C , in vars. Specify a positive value, or 0.

Measurements

Select **Branch voltages** to measure the three voltages across each phase of the Three-Phase Parallel RLC Load block terminals. For a Y connection, these voltages are the phase-to-ground or phase-to-neutral voltages. For a delta connection, these voltages are the phase-to-phase voltages.

Select **Branch currents** to measure the three total currents (sum of R, L, C currents) flowing through each phase of the Three-Phase Parallel RLC Load block. For a delta connection, these currents are the currents flowing in each branch of the delta.

Select **Branch voltages and currents** to measure the three voltages and the three currents of the Three-Phase Parallel RLC Load block.

Place a Multimeter block in your model to display the selected measurements during the simulation. In the **Available Measurements** list

Three-Phase Parallel RLC Load

box of the Multimeter block, the measurements are identified by a label followed by the block name.

Measurement		Label
Branch voltages	Y(grounded): U_{ag}, U_{bg}, U_{cg}	$U_{ag}:$, $U_{bg}:$, $U_{cg}:$
	Y(floating): U_{an}, U_{bn}, U_{cn}	$U_{an}:$, $U_{bn}:$, $U_{cn}:$
	Y(neutral): U_{an}, U_{bn}, U_{cn}	$U_{an}:$, $U_{bn}:$, $U_{cn}:$
	Delta: U_{ab}, U_{bc}, U_{ca}	$U_{ab}:$, $U_{bc}:$, $U_{ca}:$
Branch currents	Y(grounded): I_a, I_b, I_c	$I_{ag}:$, $I_{bg}:$, $I_{cg}:$
	Y(floating): I_a, I_b, I_c	$I_{an}:$, $I_{bn}:$, $I_{cn}:$
	Y(neutral): I_a, I_b, I_c	$I_{an}:$, $I_{bn}:$, $I_{cn}:$
	Delta: I_{ab}, I_{bc}, I_{ca}	$I_{ab}:$, $I_{bc}:$, $I_{ca}:$

See Also

Multimeter, Three-Phase Dynamic Load, Three-Phase Parallel RLC Branch, Three-Phase Series RLC Branch, Three-Phase Series RLC Load

Three-Phase PI Section Line

Purpose Implement a three-phase transmission line section with lumped parameters

Library Elements

Description The Three-Phase PI Section Line block implements a balanced three-phase transmission line model with parameters lumped in a PI section.

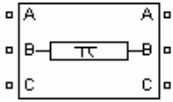

Contrary to the Distributed Parameter Line model where the resistance, inductance, and capacitance are uniformly distributed along the line, the Three-Phase PI Section Line block lumps the line parameters in a single PI section as shown in the figure below where only one phase is represented.

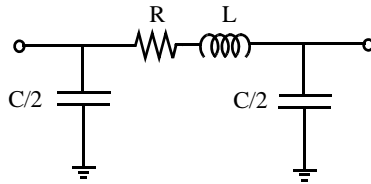

The line parameters R , L , and C are specified as positive- and zero-sequence parameters that take into account the inductive and capacitive couplings between the three phase conductors as well as the ground parameters. This method of specifying line parameters assumes that the three phases are balanced.

Using a single PI section model is appropriate for modeling short transmission lines or when the frequency range of interest is limited around the fundamental frequency. You can obtain a more accurate model by cascading several identical blocks. See the PI Section Line for explanations of the maximum frequency range that can be achieved by a PI line model.

Note The Powergui block provides a graphical tool for the calculation of the resistance, inductance, and capacitance per unit length based on the line geometry and the conductor characteristics. See the Powergui to learn on how to use this tool.

Three-Phase PI Section Line

Dialog Box and Parameters

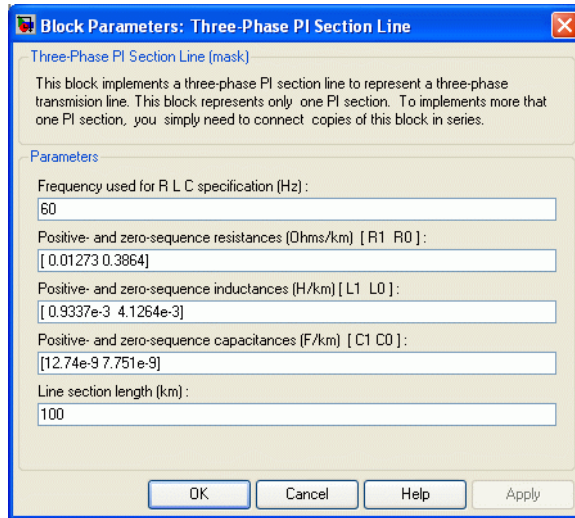

Frequency used for R L C specification

The frequency used for specification of line parameters, in hertz (Hz). This is usually the nominal system frequency (50 Hz or 60 Hz).

Positive- and zero-sequence resistances

The positive- and zero-sequence resistances in ohms/kilometer (Ω/km).

Positive- and zero-sequence inductances

The positive- and zero-sequence inductances in henries/kilometer (H/km).

Positive- and zero-sequence capacitances

The positive- and zero-sequence capacitances in farads/kilometer (F/km).

Line section length

The line section length in kilometers (km).

Example

The `power_triphaseline` demo illustrates voltage transients at the receiving end of a 200 km line when only phase A is energized. Voltages obtained with two line models are compared: 1) the Distributed Parameters Line block and 2) a PI line model using two Three-Phase PI Section Line blocks.

See Also

Distributed Parameter Line, PI Section Line

Three-Phase Programmable Voltage Source

Purpose

Implement a three-phase voltage source with programmable time variation of amplitude, phase, frequency, and harmonics

Library

Electrical Sources

Description

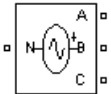

Use this block to generate a three-phase sinusoidal voltage with time-varying parameters. You can program the time variation for the amplitude, phase, or frequency of the fundamental component of the source. In addition, two harmonics can be programmed and superimposed on the fundamental signal.

Dialog Box and Parameters

Block Parameters: Three-Phase Programmable Voltage Source

Three-Phase Programmable Voltage Source [mask]

This block implements a three-phase zero-impedance voltage source. The common node (neutral) of the three sources is accessible via input 1 (N) of the block. Time variation for the amplitude, phase and frequency of the fundamental can be pre-programmed. In addition, two harmonics can be surimposed on the fundamental.

Note: For "Phasor simulation", frequency variation and harmonic injection are not allowed. Specify Order=1 and Seq=1,2 or 0 to inject additional fundamental components A and B in any sequence.

Parameters

Positive-sequence: [Amplitude(Vrms Ph-Ph) Phase(deg.) Freq. (Hz)]
[100 0 60]

Time variation of: Amplitude

Type of variation: Step

Step magnitude (pu, deg. or Hz):
0.5

Variation timing (s): [Start End]
[1 2]

Fundamental and/or Harmonic generation:

A: [Order(n) Amplitude(pu) Phase(degrees) Seq(0, 1 or 2)]
[3 0.2 -25 0]

B: [Order(n) Amplitude(pu) Phase(degrees) Seq(0, 1 or 2)]
[2 0.15 35 2]

Timing (s): [Start End]
[0.05 3]

OK Cancel Help Apply

Positive-sequence

The amplitude in volts RMS phase-to-phase, the phase in degrees, and the frequency in hertz of the positive-sequence component of the three voltages.

Three-Phase Programmable Voltage Source

Time variation of

Specify the parameter for which you want to program the time variation. Select None if you do not want to program the time variation of the source parameters. Select Amplitude if you want to program the time variation of the amplitude. Select Phase if you want to program the time variation of the phase. Select Frequency if you want to program the time variation of the frequency.

Note that the time variation applies on the three phases of the source except when the **Type of variation** parameter is set to Table of amplitude-pairs, in which case you can apply a variation on phase A only.

Type of variation

Specify the type of variation that is applied on the parameter specified by the **Time variation of** parameter. Select Step to program a step variation. Select Ramp to program a ramp variation. Select Modulation to program a modulated variation. Select Table of amplitude-pairs to program a series of step changes of amplitudes at specific times.

Step magnitude

This parameter is only visible if the **Type of Variation** parameter is set to Step.

Specify the amplitude of the step change. The variation of amplitude is specified in p.u. of the positive-sequence amplitude.

Rate of change

This parameter is only visible if the **Type of Variation** parameter is set to Ramp.

Specify the rate of change, in volt/seconds. The rate of change of voltage is specified in (p.u of the positive-sequence voltage)/second.

Amplitude of the modulation

This parameter is only visible if the **Type of variation** parameter is set to Modulation.

Specify the amplitude of the modulation for the source parameter specified in the **Time variation of** parameter. When the varying quantity is the voltage amplitude, the amplitude of the modulation is specified in p.u. of the positive-sequence amplitude.

Three-Phase Programmable Voltage Source

Frequency of the modulation

This parameter is only visible if the **Type of variation** parameter is set to Modulation.

Specify the frequency of the modulation for the source parameter specified in the **Time variation of** parameter.

Variation timing(s)

Specify the time, in seconds, when the programmed time variation takes effect and the time when it stops.

Fundamental and/or Harmonic generation

If selected, two harmonics can be programmed to be superimposed on the fundamental voltage of the source.

A: [Order Amplitude Phase Seq]

This parameter is only visible if the **Fundamental and/or Harmonic generation** check box is selected.

Specify the order, amplitude, phase, and the type of sequence (1 = positive-sequence; 2 = negative-sequence; 0 = zero-sequence) of the first harmonic to be superimposed on the fundamental signal. The voltage of the harmonic is specified in p.u. of the positive-sequence voltage.

Specify 1 for the harmonic order and 0 or 2 for the sequence to produce a voltage imbalance without harmonics.

B: [Order Amplitude Phase Seq]

This parameter is only visible if the **Fundamental and/or Harmonic generation** check box is selected.

Specify the order, amplitude, phase, and the type of sequence (0 = zero sequence, 1 = positive sequence, 2 = negative sequence) of the second harmonic to be superimposed on the fundamental signal. The voltage of the harmonic is specified in p.u. of the positive-sequence voltage.

Specify 1 for the harmonic order and 0 or 2 for the sequence to produce a voltage unbalance without harmonics.

Variation Timing(s)

This parameter is only visible if the **Fundamental and/or Harmonic generation** check box is selected.

Three-Phase Programmable Voltage Source

Specify the time, in seconds, when the harmonic generation is superimposed on the fundamental signal and the time when it stops.

Example

The `power_3phsignalseq` circuit illustrates the use of the Three-Phase Programmable Voltage Source block to produce a step variation of the positive-sequence voltage and to inject harmonics into the circuit.

A 25 kV, 100 MVA short-circuit level, equivalent network feeds a 5 MW, 2 Mvar capacitive load. The internal voltage of the source is controlled by the Discrete 3-phase Programmable Voltage Source block.

A positive sequence of 1.0 p.u., 0 degrees is specified for the fundamental signal. At $t = 0.05$ s a step of 0.5 p.u. is applied on the positive-sequence voltage magnitude, then at $t = 0.1$ s, 0.08 p.u. of fifth harmonic in negative sequence is added to the 1.5 p.u. voltage.

The three-phase voltage and current are measured at the output of the source impedance. Two Discrete Sequence Analyzer blocks are used to measure the positive-sequence fundamental component and the negative-sequence fifth harmonic of the three-phase voltage.

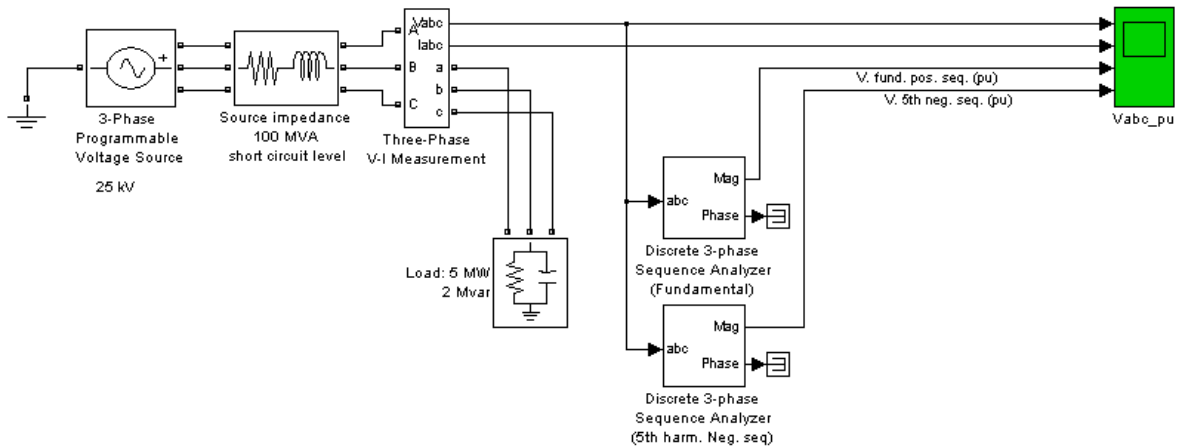

See Also

Three-Phase Source

Three-Phase Sequence Analyzer

Purpose Measure the positive-, negative-, and zero-sequence components of a three-phase signal

Library Extras/Measurements

A discrete version of this block is available in the Extras/Discrete Measurements library

Description



The Three-Phase Sequence Analyzer block outputs the magnitude and phase of the positive- (denoted by the index 1), negative- (index 2), and zero-sequence (index 0) components of a set of three balanced or unbalanced signals. The signals can contain harmonics or not. The three sequence components of a three-phase signal (voltages V_1 V_2 V_0 or currents I_1 I_2 I_0) are computed as follows:

$$V_1 = \frac{1}{3}(V_a + a \cdot V_b + a^2 \cdot V_c)$$

$$V_2 = \frac{1}{3}(V_a + a^2 \cdot V_b + a \cdot V_c)$$

$$V_0 = \frac{1}{3}(V_a + V_b + V_c)$$

where

V_a, V_b, V_c = three voltage phasors at specified frequency

$$a = e^{j2\pi/3} = 1 \angle 120 \text{ degree complex operator}$$

A Fourier analysis over a sliding window of one cycle of the specified frequency is first applied to the three input signals. It evaluates the phasor values V_a , V_b , and V_c at the specified fundamental or harmonic frequency. Then the transformation is applied to obtain the positive sequence, negative sequence, and zero sequence.

The Three-Phase Sequence Analyzer block is not sensitive to harmonics or imbalances. However, as this block uses a running average window to perform the Fourier analysis, one cycle of simulation has to be completed before the outputs give the correct magnitude and angle. For example, its response to a step change of V_1 is a one-cycle ramp.

Three-Phase Sequence Analyzer

The discrete version of this block allows you to specify the initial magnitude and phase of the output signal. For the first cycle of simulation the outputs are held to the values specified by the initial input parameter.

You can modify any parameter during the simulation in order to obtain the different sequence and harmonic components of the input signals.

Dialog Box and Parameters

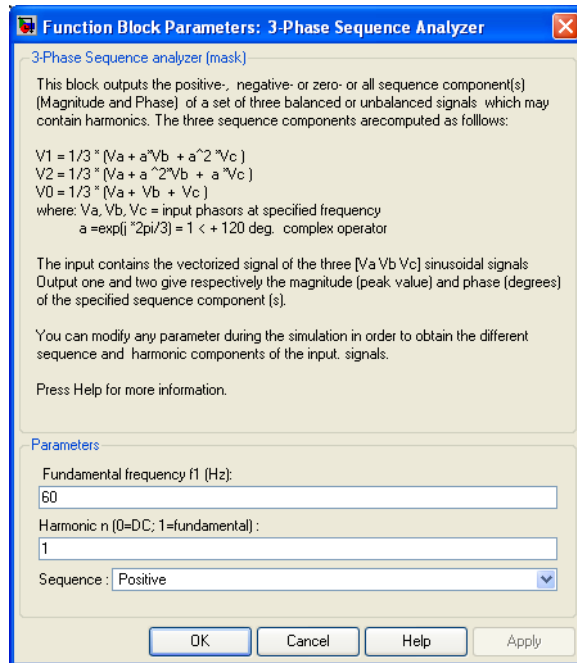

Fundamental frequency f1

The fundamental frequency, in hertz, of the three-phase input signal.

Harmonic n

Specify the harmonic component from which you want to evaluate the sequences. For DC, enter 0. For fundamental, enter 1.

Sequence

Specify which sequence component the block outputs. Select Positive to calculate the positive sequence, select Negative to calculate the negative

Three-Phase Sequence Analyzer

sequence, select 0 to compute the zero sequence of the fundamental or specified harmonic of the three-phase input signal. Select Positive Negative Zero to get all the sequences.

Inputs and Outputs

abc

Connect to the input the vectorized signal of the three [a b c] sinusoidal signals.

Mag

The first output gives the magnitude (peak value) of the specified sequence component.

Phase

The second output gives the phase in degrees of the specified component(s).

Example

The power_3phsignalseq demo illustrates the use of the Discrete Sequence Analyzer block to measure the fundamental and harmonic components of a three-phase voltage. A 25kV, 100 MVA short-circuit level, equivalent network feeds a 5 MW, 2 Mvar capacitive load. The internal voltage of the source is controlled by the Discrete 3-phase Programmable Voltage Source block.

A positive sequence of 1.0 p.u., 0 degrees is specified for the fundamental signal. At $t = 0.05$ s a step of 0.5 p.u. is applied on the positive-sequence voltage magnitude, then at $t = 0.1$ s, 0.08 p.u. of fifth harmonic in negative sequence is added to the 1.5 p.u. voltage.

Two Discrete Three-Phase Sequence Analyzer blocks are used to measure the positive-sequence fundamental component and the negative-sequence fifth harmonic of the three-phase voltage.

Three-Phase Sequence Analyzer

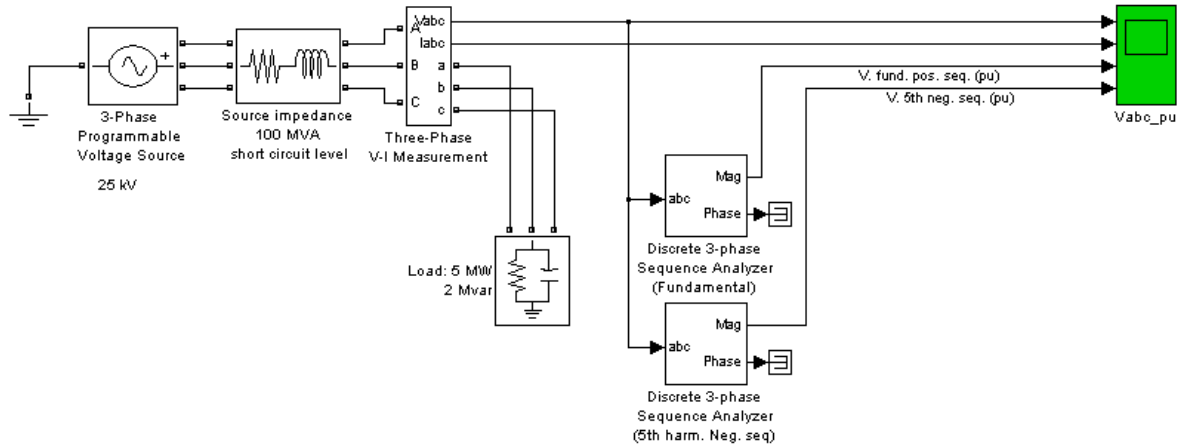

As the Three-Phase Sequence Analyzer blocks use Fourier analysis, their response time is delayed by one cycle of the fundamental frequency.

Three-Phase Series RLC Branch

Purpose Implement a three-phase series RLC branch

Library Elements

Description



The Three-Phase Series RLC Branch block implements three balanced branches consisting each of a resistor, an inductor, or a capacitor or a series combination of these. To eliminate either the resistance, inductance, or capacitance of each branch, the R, L, and C values must be set respectively to 0, 0, and infinity (inf). Only existing elements are displayed in the block icon.

Negative values are allowed for resistance, inductance, and capacitance.

Dialog Box and Parameters

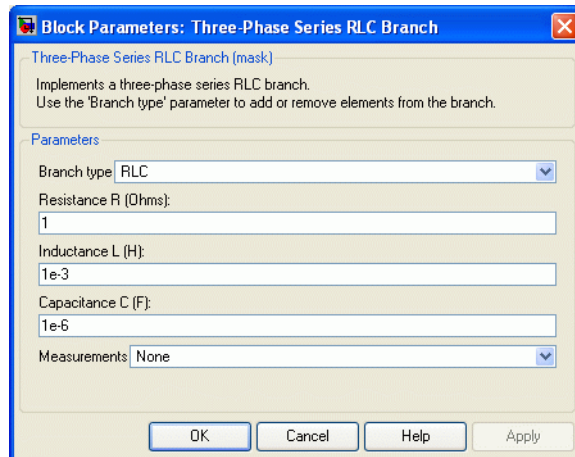

Branch Type

Select the elements you want to include in the branch. The **R** letter defines the resistor, the **L** letter defines the inductor, and the **C** letter defines the capacitor.

Resistance R

The branch resistances, in ohms (Ω).

Inductance L

The branch inductances, in henries (H).

Three-Phase Series RLC Branch

Capacitance C

The branch capacitances, in farads (F).

Measurements

Select Branch voltages to measure the three voltages across the Three-Phase Series RLC Branch block terminals.

Select Branch currents to measure the three currents flowing through the Three-Phase Series RLC Branch block.

Select Branch voltages and currents to measure the three voltages and the three currents of the Three-Phase Series RLC Branch block.

Place a Multimeter block in your model to display the selected measurements during the simulation. In the **Available Measurements** list box of the Multimeter block, the measurements are identified by a label followed by the block name.

Measurement	Label
Branch voltages of phases A, B, and C	Ua: , Ub: , Uc:
Branch currents of phases A, B, and C	Ia: , Ib: , Ic:

See Also

Multimeter, Three-Phase Parallel RLC Branch, Three-Phase Parallel RLC Load, Three-Phase Series RLC Load

Three-Phase Series RLC Load

Purpose Implement a three-phase series RLC load with selectable connection

Library Elements

Description

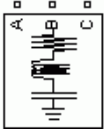

The Three-Phase Series RLC Load block implements a three-phase balanced load as a series combination of RLC elements. At the specified frequency, the load exhibits a constant impedance. The active and reactive powers absorbed by the load are proportional to the square of the applied voltage.

Only elements associated with nonzero powers are displayed in the block icon.

Dialog Box and Parameters

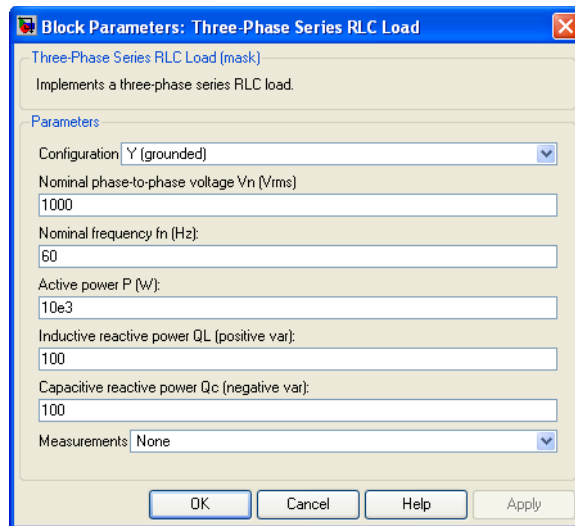

Configuration

The connection of the three phases. Select one of the following four connections:

Y (grounded)

Neutral is grounded.

Y (floating)

Neutral is not accessible.

Three-Phase Series RLC Load

Y (neutral)	Neutral is made accessible through a fourth connector.
Delta	Three phases connected in delta

The block icon is updated according to the load connection.

Nominal phase-to-phase voltage V_n

The nominal phase-to-phase voltage of the load, in volts RMS (V_{rms}).

Nominal frequency f_n

The nominal frequency, in hertz (Hz).

Active power P

The three-phase active power of the load, in watts (W).

Inductive reactive power Q_L

The three-phase inductive reactive power Q_L , in vars. Specify a positive value, or 0.

Capacitive reactive power Q_c

The three-phase capacitive reactive power Q_C , in vars. Specify a positive value, or 0.

Measurements

Select Branch voltages to measure the three voltages across each phase of the Three-Phase Series RLC Load block terminals. For a Y connection, these voltages are the phase-to-ground or phase-to-neutral voltages. For a delta connection, these voltages are the phase-to-phase voltages.

Select Branch currents to measure the three total currents (sum of R, L, C currents) flowing through each phase of the Three-Phase Series RLC Load block. For a delta connection, these currents are the currents flowing in each branch of the delta.

Select Branch voltages and currents to measure the three voltages and the three currents of the Three-Phase Series RLC Load block.

Place a Multimeter block in your model to display the selected measurements during the simulation. In the **Available Measurements** list

Three-Phase Series RLC Load

box of the Multimeter block, the measurements are identified by a label followed by the block name.

Measurement		Label
Branch voltages	Y(grounded): Uag, Ubg, Ucg	Uag: , Ubg: , Ucg:
	Y(floating): Uan, Ubn, Ucn	Uan: , Ubn: , Ucn:
	Y(neutral): Uan, Ubn, Ucn	Uan: , Ubn: , Ucn:
	Delta: Uab, Ubc, Uca	Uab: , Ubc: , Uca:
Branch currents	Y(grounded): Ia, Ib, Ic	Iag: , Ibg: , Icg:
	Y(floating): Ia, Ib, Ic	Ian: , Ibn: , Icn:
	Y(neutral): Ia, Ib, Ic	Ian: , Ibn: , Icn:
	Delta: Iab, Ibc, Ica	Iab: , Ibc: , Ica:

See Also

Multimeter, Three-Phase Dynamic Load, Three-Phase Parallel RLC Branch, Three-Phase Parallel RLC Load, Three-Phase Series RLC Branch

Purpose Implement a three-phase source with internal R-L impedance

Library Electrical Sources

Description

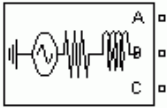

The Three-Phase Source block implements a balanced three-phase voltage source with an internal R-L impedance. The three voltage sources are connected in Y with a neutral connection that can be internally grounded or made accessible. You can specify the source internal resistance and inductance either directly by entering R and L values or indirectly by specifying the source inductive short-circuit level and X/R ratio.

Dialog Box and Parameters

Block Parameters: Three-Phase Source

Three-Phase Source (mask)
Three-phase voltage source in series with RL branch.

Parameters

Phase-to-phase rms voltage (V):
25e3

Phase angle of phase A (degrees):
0

Frequency (Hz):
60

Internal connection: Yg

Specify impedance using short-circuit level

3-phase short-circuit level at base voltage(VA):
100e6

Base voltage (Vrms ph-ph):
25e3

X/R ratio:
7

OK Cancel Help Apply

Phase-to-phase rms voltage

The internal phase-to-phase voltage in volts RMS (Vrms)

Phase angle of phase A

The phase angle of the internal voltage generated by phase A, in degrees. The three voltages are generated in positive sequence. Thus, phase B and phase C internal voltages are lagging phase A respectively by 120 degrees and 240 degrees.

Three-Phase Source

Frequency

The source frequency in hertz (Hz).

Internal connection

The internal connection of the three internal voltage sources. The block icon is updated according to the source connection.

Select one of the following three connections:

- | | |
|----|--|
| Y | The three voltage sources are connected in Y to an internal floating neutral. |
| Yn | The three voltage sources are connected in Y to a neutral connection which is made accessible through a fourth terminal. |
| Yg | The three voltage sources are connected in Y to an internally grounded neutral. |

Specify impedance using short-circuit level

Select to specify internal impedance using the inductive short-circuit level and X/R ratio.

3-phase short-circuit level at base voltage

The three-phase inductive short-circuit power, in volts-amperes (VA), at specified base voltage, used to compute the internal inductance L. This parameter is available only if **Specify impedance using short-circuit level** is selected.

The internal inductance L (in H) is computed from the inductive three-phase short-circuit power Psc (in VA), base voltage Vbase (in Vrms phase-to-phase), and source frequency f (in Hz) as follows:

$$L = \frac{(V_{base})^2}{P_{sc}} \cdot \frac{1}{2\pi f}$$

Base voltage

The phase-to-phase base voltage, in volts RMS, used to specify the three-phase short-circuit level. The base voltage is usually the nominal source voltage. This parameter is available only if **Specify impedance using short-circuit level** is selected.

X/R ratio

The X/R ratio at nominal source frequency or quality factor of the internal source impedance. This parameter is available only if **Specify impedance using short-circuit level** is selected.

The internal resistance R (in Ω) is computed from the source reactance X (in Ω) at specified frequency, and X/R ratio as follows:

$$R = \frac{X}{(X/R)} = \frac{2\pi fL}{(X/R)}$$

Source resistance

This parameter is available only if **Specify impedance using short-circuit level** is not selected.

The source internal resistance in ohms (Ω).

Source inductance

This parameter is available only if **Specify impedance using short-circuit level** is not selected.

The source internal inductance in henries (H).

Note Either resistance or inductance of the source can be set to zero, but not both at the same time. The block icon is updated accordingly.

Example

See the power_3phseriescomp demo, which uses a Three-Phase Source block to model a portion of a 735 kV system with a simplified R-L source. The source impedance is specified by using the three-phase short-circuit level (30,000 MVA) and X/R ratio ($X/R = 10$).

See Also

Three-Phase Programmable Voltage Source

Three-Phase Transformer 12 Terminals

Purpose

Implement three single-phase, two-winding transformers where all terminals are accessible

Library

Elements

Description

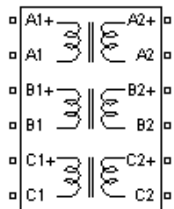

The Three-Phase Transformer 12 Terminals block implements three single-phase, two-winding linear transformers where all the twelve winding connectors are accessible. The block can be used in place of the Three-Phase Transformer (Two Windings) block to implement a three-phase transformer when primary and secondary are not necessarily connected in Y or Delta.

Dialog Box and Parameters

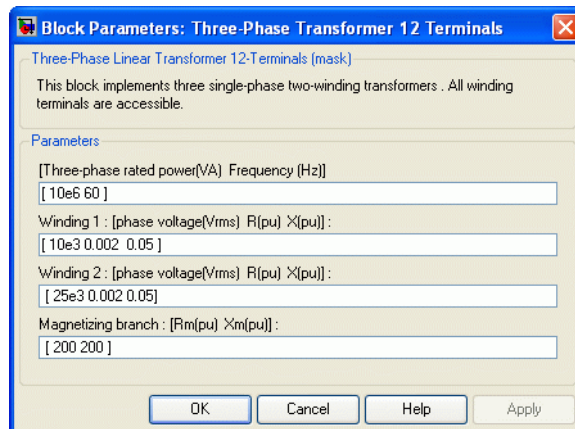

[Three-phase rated power Frequency]

The total nominal power of the three phases, in volt-amperes (VA), and the nominal frequency, in hertz (Hz).

Winding 1: [phase voltage R X]

The nominal voltage of the three primary windings (labeled 1) in volts RMS (Vrms), the winding resistances, in p.u., and the winding leakage reactances, in p.u.

Three-Phase Transformer 12 Terminals

Winding 2: [phase voltage R X]

The nominal voltage of the three secondary windings (labeled 2) in volts RMS (V_{rms}), the winding resistances, in p.u., and the winding leakage reactances, in p.u.

Magnetizing branch: [Rm Xm]

The resistance and reactance simulating the core active and reactive losses, both in p.u. For example, to specify 0.2% of active and reactive core losses, at nominal voltage, use $R_m = 500$ p.u. and $L_m = 500$ p.u. L_m can be set to ∞ (no reactive core losses), but R_m must have a finite value.

Note Refer to the Linear Transformer for explanations on the per unit system.

Example

See the power_3phPWM demo for an example of use of the Three-Phase Transformer 12 Terminals block in a three-phase double-bridge voltage-sourced converter.

See Also

Linear Transformer, Three-Phase Transformer (Two Windings)

Three-Phase Transformer (Two Windings)

Purpose Implement a three-phase transformer with configurable winding connections

Library Elements

Description

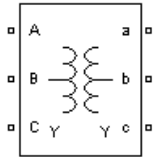

The Three-Phase Transformer (Two Windings) block implements a three-phase transformer using three single-phase transformers. You can simulate the saturable core or not simply by setting the appropriate check box in the parameter menu of the block. See the Linear Transformer block and Saturable Transformer block sections for a detailed description of the electrical model of a single-phase transformer.

The two windings of the transformer can be connected in the following manner:

- Y
- Y with accessible neutral
- Grounded Y
- Delta (D1), delta lagging Y by 30 degrees
- Delta (D11), delta leading Y by 30 degrees

Note The D1 and D11 notations refer to the following clock convention. It assumes that the reference Y voltage phasor is at noon (12) on a clock display. D1 and D11 refer respectively to 1 PM (delta voltages lagging Y voltages by -30 degrees) and 11 AM (delta voltages leading Y voltages by +30 degrees).

The block takes into account the connection type you have selected, and the icon of the block is automatically updated. An input port labeled N is added to the block if you select the Y connection with accessible neutral for winding 1. If you ask for an accessible neutral on winding 2, an extra output port labeled n is generated.

The saturation characteristic, when activated, is the same as the one described for the Saturable Transformer block, and the icon of the block is automatically updated. If the fluxes are not specified, the initial values are automatically adjusted so that the simulation starts in steady state.

The leakage inductance and resistance of each winding are given in p.u. based on the transformer nominal power P_n and on the nominal voltage of the

Three-Phase Transformer (Two Windings)

winding (V1 or V2). For an explanation of per units, refer to the Linear Transformer and to the Saturable Transformer.

Dialog Box and Parameters

Block Parameters: Three-Phase Transformer (Two Windings)

Three-Phase Transformer [Two Windings] (mask) (link)

This block implements a three-phase transformer by using three single-phase transformers. Set the winding connection to 'Yn' when you want to access the neutral point of the Wye.

Click the Apply or the OK button after a change to the Units popup to confirm the conversion of parameters.

Parameters

Units: pu

Nominal power and frequency [Pn(VA) , fn(Hz)]
[250e6 , 60]

Winding 1 (ABC) connection: Y

Winding parameters [V1 Ph-Ph(Vrms) , R1(pu) , L1(pu)]
[735e3 , 0.002 , 0.08]

Winding 2 (abc) connection: Y

Winding parameters [V2 Ph-Ph(Vrms) , R2(pu) , L2(pu)]
[315e3 , 0.002 , 0.08]

Saturable core

Magnetization resistance Rm (pu)
500

Simulate hysteresis

Hysteresis Data Mat file
'hysteresis'

Specify initial fluxes

[phi0A , phi0B , phi0C] (pu):
[0.8 , -0.8 , 0.7]

Measurements: None

Show additional parameters

Break Algebraic loop in discrete saturation model

OK Cancel Help Apply

Units

Specify the units used to enter the parameters of the Three Phase Transformer block. Select pu to use per unit. Select SI to use SI units. Changing the **Units** parameter from pu to SI, or from SI to pu, will automatically convert the parameters displayed in the mask of the block.

Three-Phase Transformer (Two Windings)

Nominal power and frequency

The nominal power rating, in volt-amperes (VA), and nominal frequency, in hertz (Hz), of the transformer.

Winding 1 (ABC) connection

The winding connections for winding 1.

Winding parameters

The phase-to-phase nominal voltage in volts RMS, resistance, and leakage inductance in p.u. for winding 1.

Winding 2 (abc) connection

The winding connections for winding 2.

Winding parameters

The phase-to-phase nominal voltage in volts RMS, resistance, and leakage inductance in p.u. for winding 2.

Saturable core

If selected, implements a saturable three-phase transformer.

Magnetization resistance R_m

The magnetization resistance R_m , in p.u.

Magnetization reactance L_m

The **Magnetization reactance L_m** parameter is not visible in the dialog box if the **Saturable core** parameter is selected.

The magnetization inductance L_m , in p.u., for a nonsaturable core.

Saturation characteristic

This parameter is visible only if the **Saturable core** parameter is selected.

The saturation characteristic for the saturable core. Specify a series of current/ flux pairs (in p.u.) starting with the pair (0,0).

Simulate hysteresis

Select to model a saturation characteristic including hysteresis instead of a single-valued saturation curve.

Three-Phase Transformer (Two Windings)

Hysteresis data MAT file

This parameter is visible only if the **Simulate hysteresis** parameter is selected.

Specify a .mat file containing the data to be used for the hysteresis model. When you open the **Hysteresis Design tool** of the Powergui, the default hysteresis loop and parameters saved in the hysteresis .mat file are displayed. Use the **File** → **Load a model** menu of the **Hysteresis Design tool** to load another .mat file. Use the **File** → **Save this model** menu of the **Hysteresis Design tool** to save your model in a new .mat file.

Specify initial fluxes

If selected, the initial fluxes are defined by the [phi0A phi0B phi0C] parameter.

[phi0A phi0B phi0C]

Specify initial fluxes for each phase of the transformer. This parameter is visible only if the **Specify initial fluxes** and **Saturable core** parameters are selected.

Measurements

Select **Winding voltages** to measure the voltage across the winding terminals of the Three-Phase Transformer block.

Select **Winding currents** to measure the current flowing through the windings of the Three-Phase Transformer block.

Select **Fluxes and excitation currents (Im + IRm)** to measure the flux linkage, in volt seconds (V.s), and the total excitation current including iron losses modeled by Rm (for saturable transformers only).

Select **Fluxes and magnetization currents (Im)** to measure the flux linkage, in volt seconds (V.s), and the magnetization current, in amperes (A), not including iron losses modeled by Rm (for saturable transformers only).

Select **All measurements (V, I, Flux)** to measure the winding voltages, currents, magnetization currents, and the flux linkages.

Place a **Multimeter** block in your model to display the selected measurements during the simulation. In the **Available Measurements** list

Three-Phase Transformer (Two Windings)

box of the Multimeter block, the measurements are identified by a label followed by the block name.

If the **Winding 1 ABC connection** parameter is set to Y, Yn, or Yg, the labels are as follows).

Measurement	Label
Winding 1 voltages	Uan_w1:, Ubn_w1:, Ucn_w1: or Uag_w1:, Ubg_w1:, Ucg_w1:
Winding 1 currents	Ian_w1:, Ibn_w1:, Icn_w1: or Iag_w1:, Ibg_w1:, Icg_w1:
Fluxes	Flux_A:, Flux_B:, Flux_C:
Magnetization currents	Imag_A:, Imag_B:, Imag_C:
Excitation currents	Iexc_A:, Iexc_B:, Iexc_C:

The same labels apply for winding 2, except that 1 is replaced by 2 in the labels.

If the **Winding 1 ABC connection** parameter is set to Delta (D11) or Delta (D1), the labels are as follows.

Measurement	Label
Winding 1 voltages	Uab_w1:, Ubc_w1:, Uca_w1:
Winding 1 currents	Iab_w1:, Ibc_w1:, Ica_w1:
Flux linkages	Flux_A:, Flux_B:, Flux_C:
Magnetization currents	Imag_A:, Imag_B:, Imag_C:
Excitation currents	Iexc_A:, Iexc_B:, Iexc_C:

Three-Phase Transformer (Two Windings)

Example

The power_transfo3ph circuit uses the Three-Phase Transformer block where the saturable core is simulated. Both windings are connected in a Y grounded configuration. Note that the neutral points of the two windings are internally connected to the ground.

The 500 kV/ 230 kV saturable transformer is energized on the 500 kV system. Remanent fluxes of 0.8 p.u., -0.4 p.u., and 0.4 p.u. have been specified respectively for phases A, B, and C.

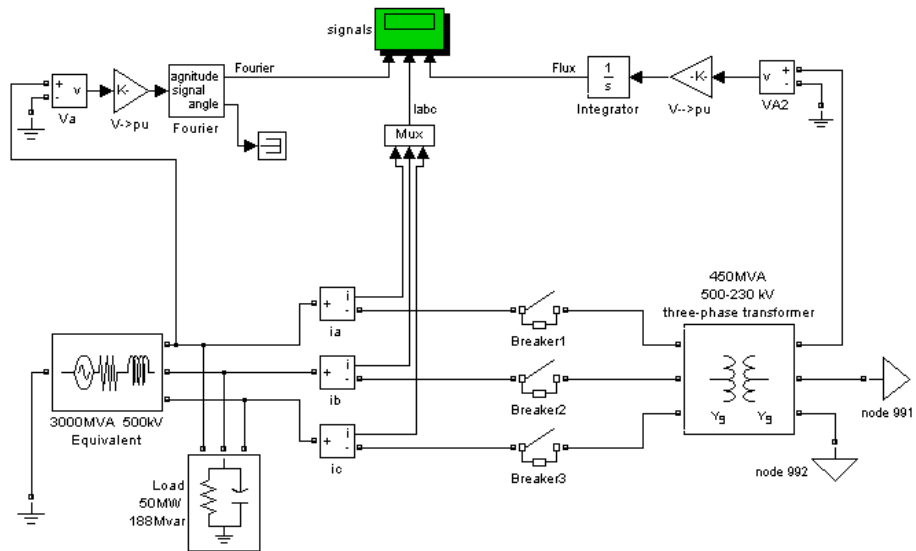

Run the simulation and observe inrush currents due to core saturation.

Three-Phase Transformer (Two Windings)

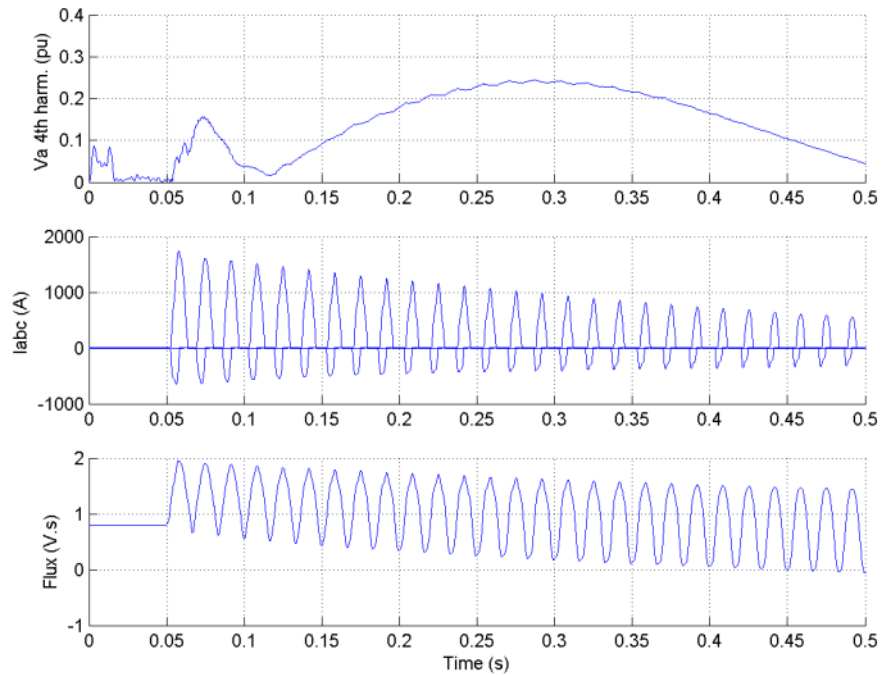

See Also

Linear Transformer, Multimeter, Saturable Transformer, Three-Phase Transformer (Three Windings)

Three-Phase Transformer (Three Windings)

Purpose Implement a three-phase transformer with configurable winding connections

Library Elements

Description This block implements a three-phase transformer by using three single-phase transformers with three windings. You can simulate the saturable core or not simply by setting the appropriate check box in the parameter menu of the block. See the Linear Transformer and Saturable Transformer block sections for a detailed description of the electrical model of a single-phase transformer.

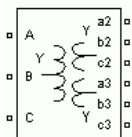

The three windings of the transformer can be connected in the following manner:

- Y
- Y with accessible neutral (for windings 1 and 3 only)
- Grounded Y
- Delta (D1), delta lagging Y by 30 degrees
- Delta (D11), delta leading Y by 30 degrees

Note The D1 and D11 notations refer to the following clock convention. It assumes that the reference Y voltage phasor is at noon (12) on a clock display. D1 and D11 refer respectively to 1 PM (delta voltages lagging Y voltages by -30 degrees) and 11 AM (delta voltages leading Y voltages by $+30$ degrees).

The block takes into account the connection type you select, and the icon of the block is automatically updated. An input port labeled N is added to the block if you select the Y connection with accessible neutral for winding 1. If you ask for an accessible neutral on winding 3, an extra output port labeled n3 is generated.

The saturation characteristic, when activated, is the same as the one described for the Saturable Transformer block, and the icon of the block is automatically updated. If the fluxes are not specified, the initial values are automatically adjusted so that the simulation starts in steady state.

The leakage inductances and resistance of each winding are given in p.u. based on the transformer nominal power P_n and on the nominal voltage of the

Three-Phase Transformer (Three Windings)

winding (V1, V2, or V3). For an explanation of per units, refer to the Linear Transformer and to the Saturable Transformer.

Dialog Box and Parameters

Block Parameters: Three-Phase Transformer (Three Windings)

Three-Phase Transformer (Three Windings) (mask) (link)

This block implements a three-phase transformer by using three single-phase transformers. Set the winding connection to 'Yn' when you want to access the neutral point of the Wye (for winding 1 and 3 only).

Click the Apply or the OK button after a change to the Units popup to confirm the conversion of parameters.

Parameters

Units: pu

Nominal power and frequency [Pn(VA) , fn(Hz)]
[250e6 , 60]

Winding 1 (ABC) connection: Y

Winding parameters [V1 Ph-Ph(Vrms) , R1(pu) , L1(pu)]
[735e3 , 0.002 , 0.08]

Winding 2 (abc-2) connection: Y

Winding parameters [V2 Ph-Ph(Vrms) , R2(pu) , L2(pu)]
[315e3 , 0.002 , 0.08]

Winding 3 (abc-3) connection: Y

Winding parameters [V3 Ph-Ph(Vrms) , R3(pu) , L3(pu)]
[315e3 , 0.002 , 0.08]

Saturable core

Magnetization resistance Rm(pu):
500

Simulate hysteresis

Hysteresis Data Mat file
'hysteresis'

Specify initial fluxes:

[phi0A phi0B phi0C] (pu)
[0.8 -0.8 0.7]

Measurements: None

..... Show additional parameters

Break Algebraic loop in discrete saturation model

OK Cancel Help Apply

Units

Specify the units used to enter the parameters of the Three Phase Transformer block. Select pu to use per unit. Select SI to use SI units. Changing the **Units** parameter from pu to SI, or from SI to pu, will automatically convert the parameters displayed in the mask of the block.

Three-Phase Transformer (Three Windings)

Nominal power and frequency

The nominal power rating, in volt-amperes (VA), and nominal frequency, in hertz (Hz), of the transformer.

Winding 1 (ABC) connection

The winding connection for winding 1.

Winding parameters

The phase-to-phase nominal voltage in volts RMS, resistance, and leakage inductance in p.u. for winding 1.

Winding 2 (abc2) connection

The winding connection for winding 2.

Winding parameters

The phase-to-phase nominal voltage in volts RMS, resistance, and leakage inductance in p.u. for winding 2.

Winding 3 (abc3) connection

The winding connection for winding 3.

Winding parameters

The phase-to-phase nominal voltage in volts RMS, resistance, and leakage inductance in p.u. for winding 3.

Saturable core

If selected, implements a saturable three-phase transformer.

Magnetization resistance Rm

The magnetization resistance Rm, in p.u.

Magnetization reactance Lm

The magnetization inductance Lm, in p.u., for a nonsaturable core. The **Magnetization reactance Lm** parameter is not visible in the dialog box if the **Saturable core** parameter is selected.

Saturation characteristic

This parameter is visible only if the **Saturable core** parameter is selected.

The saturation characteristic for the saturable core. Specify a series of current/ flux pairs (in p.u.) starting with the pair (0,0).

Three-Phase Transformer (Three Windings)

Simulate hysteresis

Select to model a saturation characteristic including hysteresis instead of a single-valued saturation curve.

Hysteresis data MAT file

This parameter is visible only if the **Simulate hysteresis** parameter is selected.

Specify a `.mat` file containing the data to be used for the hysteresis model. When you open the **Hysteresis Design tool** of the Powergui, the default hysteresis loop and parameters saved in the hysteresis `.mat` file are displayed. Use the **File** → **Load a model** menu of the **Hysteresis Design tool** to load another `.mat` file. Use the **File** → **Save this model** menu of the **Hysteresis Design tool** to save your model in a new `.mat` file.

Specify initial fluxes

If selected, the initial fluxes are defined by the `[phi0A phi0B phi0C]` parameter.

`[phi0A phi0B phi0C]`

Specifies initial fluxes for each phase of the transformer. This parameter is visible only if the **Specify initial fluxes** and **Saturable core** parameters are selected.

Measurements

Select **Winding voltages** to measure the voltage across the winding terminals of the Three-Phase Transformer block.

Select **Winding currents** to measure the current flowing through the windings of the Three-Phase Transformer block.

Select **Fluxes** and excitation currents ($I_m + I_{Rm}$) to measure the flux linkage, in volt seconds (V.s), and the total excitation current including iron losses modeled by R_m (for saturable transformers only).

Select **Fluxes** and magnetization currents (I_m) to measure the flux linkage, in volt seconds (V.s), and the magnetization current, in amperes (A), not including iron losses modeled by R_m (for saturable transformers only).

Select **All measurements (V, I, Flux)** to measure the winding voltages, currents, magnetization currents, and the flux linkages.

Three-Phase Transformer (Three Windings)

Place a Multimeter block in your model to display the selected measurements during the simulation. In the **Available Measurements** list box of the Multimeter block, the measurements are identified by a label followed by the block name.

If the **Winding 1 ABC connection** parameter is set to Y, Yn, or Yg, the labels are as follows.

Measurement	Label
Winding 1 voltages	Uan_w1:, Ubn_w1:, Ucn_w1: or Uag_w1:, Ubg_w1:, Ucg_w1:
Winding 1 currents	Ian_w1:, Ibn_w1:, Icn_w1: or Iag_w1:, Ibg_w1:, Icg_w1:
Flux linkages	Flux_A:, Flux_B:, Flux_C:
Magnetization currents	Imag_A:, Imag_B:, Imag_C:
Excitation currents	Iexc_A:, Iexc_B:, Iexc_C:

The same labels apply for winding 2 and winding 3, except that the 1 is replaced by 2 or by 3 in the labels.

If the **Winding 1 ABC connection** parameter is set to Delta (D11) or Delta (D1), the labels are as follows.

Measurement	Label
Winding 1 voltages	Uab_w1:, Ubc_w1:, Uca_w1:
Winding 1 currents	Iab_w1:, Ibc_w1:, Ica_w1:
Flux linkages	Flux_A:, Flux_B:, Flux_C:
Magnetization currents	Imag_A:, Imag_B:, Imag_C:
Excitation currents	Iexc_A:, Iexc_B:, Iexc_C:

Three-Phase Transformer (Three Windings)

Example

The power_transfo3wdn circuit uses two Three-Phase Transformer blocks. Two Multimeter blocks are used to measure the phase A voltage (or AB for delta connections) of each winding

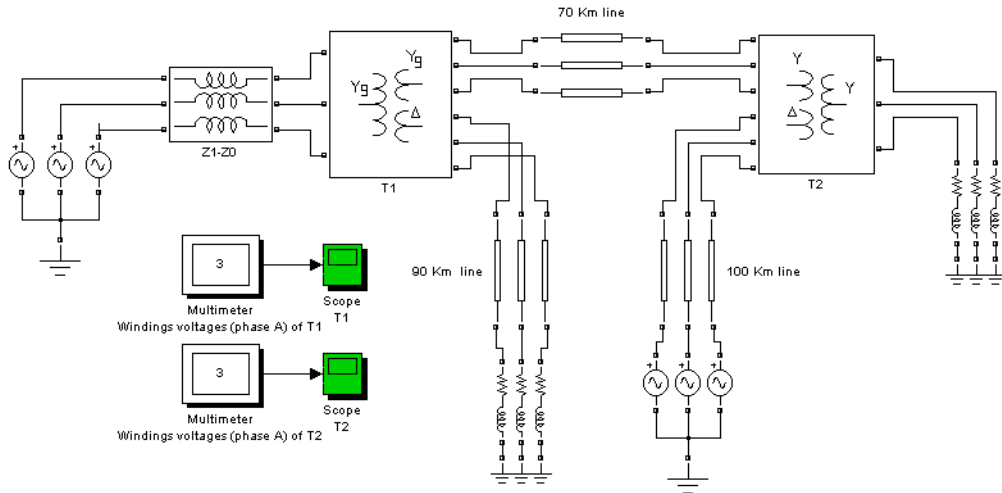

See Also

Linear Transformer, Multimeter, Saturable Transformer, Three-Phase Transformer (Two Windings)

Three-Phase V-I Measurement

Purpose Measure three-phase currents and voltages in a circuit

Library Measurements

Description

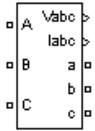

The Three-Phase V-I Measurement block is used to measure three-phase voltages and currents in a circuit. When connected in series with three-phase elements, it returns the three phase-to-ground or phase-to-phase voltages and the three line currents.

The block can output the voltages and currents in per unit (p.u.) values or in volts and amperes. If you choose to measure the voltages and currents in p.u., the Three-Phase V-I Measurement block does the following conversions:

$$V_{abc}(\text{p.u.}) = \frac{V_{abc}(\text{volts})}{\left(\frac{V_{baseLL}}{\sqrt{3}} \cdot \sqrt{2}\right)}$$

$$I_{abc}(\text{p.u.}) = \frac{I_{abc}(\text{amperes})}{\left(\frac{P_{base}}{V_{baseLL} \cdot \sqrt{3}} \cdot \sqrt{2}\right)}$$

where V_{baseLL} is the base line-to-line voltage in volts RMS and P_{base} is the three-phase base power in volts-amperes. The two base values V_{baseLL} and P_{base} are specified in the Three-Phase Measurement block menu.

The steady-state voltage and current phasors measured by the Three-Phase V-I Measurement block can be obtained from the Powergui block by selecting **Steady-State Voltages and Currents**. The phasor magnitudes displayed in the Powergui stay in peak or RMS values even if the output signals are converted to p.u.

Three-Phase V-I Measurement

Dialog Box and Parameters

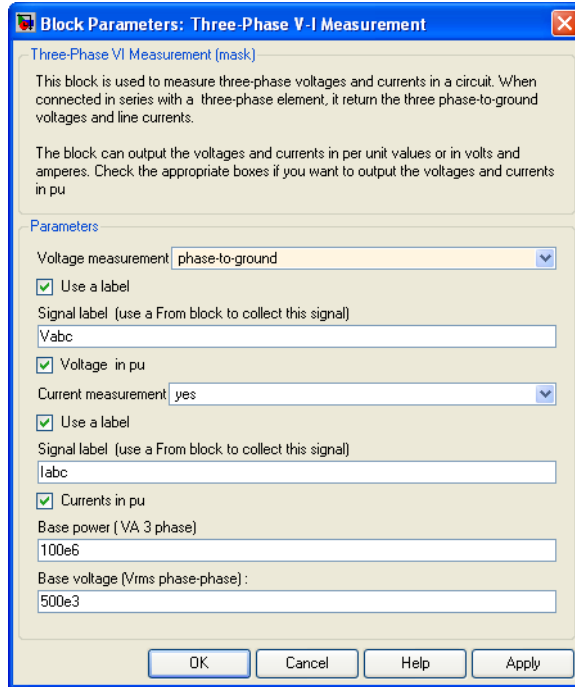

Voltage measurement

Select no if you do not want to measure three-phase voltage. Select phase-to-ground if you want to measure the phase-to-ground voltages. Select phase-to-phase if you want to measure the phase-to-phase voltages.

Use a label

If selected, the voltage measurements are sent to a labeled signal. Use a From block to read the voltages. The Goto tag of the From block must correspond to the label specified by the **Signal label** parameter. If not selected, the voltage measurements are available via the Vabc output of the block.

Signal label

Specifies a label tag for the voltage measurements.

Three-Phase V-I Measurement

Voltages in p.u.

If selected, the three-phase voltages are measured in p.u. Otherwise they are measured in volts.

Base voltage (Vrms phase-phase)

The base voltage, in volts RMS, used to convert the measured voltages in p.u. The **Base voltage (Vrms phase-phase)** parameter is not visible in the dialog box if `Voltages in p.u.` is not selected.

Current measurement

Select yes if you want to measure the three-phase currents that flow through the block.

Use a label

If selected, the current measurements are sent to a labeled signal. Use a From block to read the currents. The Goto tag of the From block must correspond to the label specified by the **Signal label** parameter. If not selected, the current measurements are available via the `Iabc` output of the block.

Signal label

Specifies a label tag for the current measurements.

Currents in p.u.

If selected, the three-phase currents are measured in p.u. Otherwise they are measured in amperes.

Base power (VA 3 phase)

The three-phase base power, in volt-ampere (VA), used to convert the measured currents in p.u. The **Base power (VA 3 phase)** parameter is not visible in the dialog box if `Currents in p.u.` is not selected.

Output signal

Specifies the format of the measured signals when the block is used in a phasor simulation. The **Output signal** parameter is disabled when the block is not used in a phasor simulation. The phasor simulation is activated by a Powergui block placed in the model.

Set to Complex to output the measured voltages and currents as complex values. The outputs are complex signals.

Three-Phase V-I Measurement

Set to Real-Imag to output the real and imaginary parts of the measured voltages and currents.

Set to Magnitude-Angle to output the magnitudes and angles of the measured voltages and currents.

Set to Magnitude to output the magnitudes of the measured voltages and currents. The output is a scalar value.

Inputs and Outputs

Vabc

The three measured phase-to-ground or phase-to-phase voltages. The Vabc output disappears when the **Use a label** parameter is selected or when the **Voltage measurement** menu is set to no.

Iabc

The three measured line currents. The Iabc output disappears when the **Use a label** parameter is selected or when the **Current measurement** menu is set to no.

Example

See the power_3phseriescomp demo for a circuit using the Three-Phase V-I Measurement block.

Purpose Implement a thyristor model

Library Power Electronics

Description The thyristor is a semiconductor device that can be turned on via a gate signal. The thyristor model is simulated as a resistor R_{on} , an inductor L_{on} , and a DC voltage source representing the forward voltage V_f , connected in series with a switch. The switch is controlled by a logical signal depending on the voltage V_{ak} , the current I_{ak} , and the gate signal g .

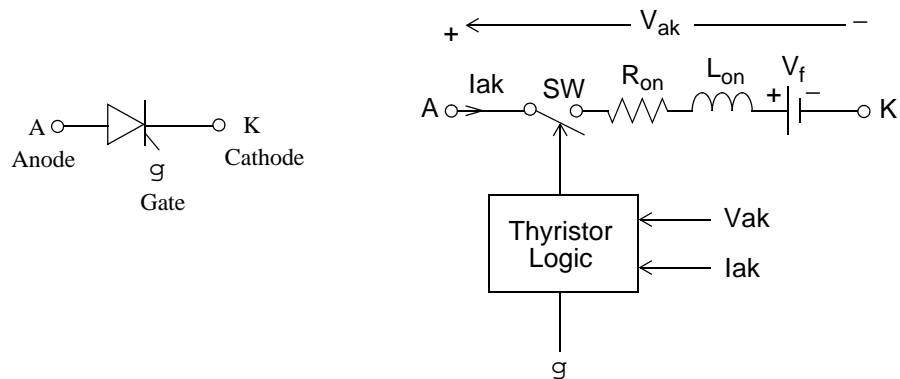
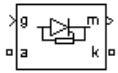

The Thyristor block also contains a series Rs-Cs snubber circuit that can be connected in parallel with the thyristor device.

The static VI characteristic of this model is shown below.

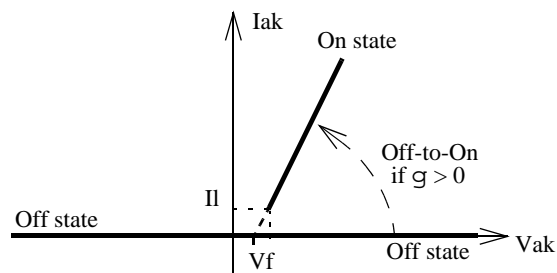

Thyristor

The thyristor device turns on when the anode-cathode V_{ak} voltage is greater than V_f and a positive pulse signal is applied at the gate input ($g > 0$). The pulse height must be greater than 0 and last long enough to allow the thyristor anode current to become larger than the latching current I_l .

The thyristor device turns off when the current flowing in the device becomes 0 ($I_{ak} = 0$) and a negative voltage appears across the anode and cathode for at least a period of time equal to the turnoff time T_q . If the voltage across the device becomes positive within a period of time less than T_q , the device turns on automatically even if the gate signal is low ($g = 0$) and the anode current is less than the latching current. Furthermore, if during turn-on, the device current amplitude stays below the latching current level specified in the dialog box, the device turns off after the gate signal level becomes low ($g = 0$).

The turnoff time T_q represents the carrier recovery time: it is the time interval between the instant the anode current has decreased to 0 and the instant when the thyristor is capable of withstanding positive voltage V_{ak} without turning on again.

Dialog Box and Parameters

Thyristor Model and Detailed Thyristor Model

In order to optimize simulation speed, two models of thyristors are available: the thyristor model and the detailed thyristor model. For the thyristor model, the latching current I_l and recovery time T_q are assumed to be 0.

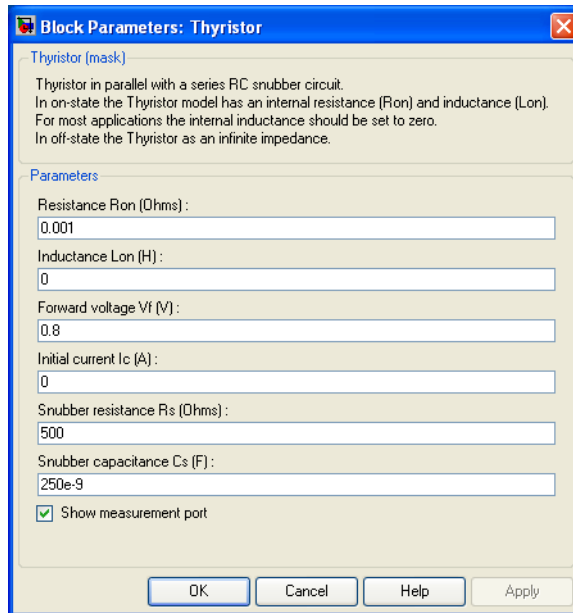

Resistance Ron

The thyristor internal resistance R_{on} , in ohms (Ω). The **Resistance Ron** parameter cannot be set to 0 when the **Inductance Lon** parameter is set to 0.

Inductance Lon

The thyristor internal inductance L_{on} , in henries (H). The **Inductance Lon** parameter is normally set to 0 except when the **Resistance Ron** parameter is set to 0.

Forward voltage Vf

The forward voltage of the thyristor, in volts (V).

Thyristor

Initial current I_c

When the **Inductance L_{on}** parameter is greater than 0, you can specify an initial current flowing in the thyristor. It is usually set to 0 in order to start the simulation with the thyristor blocked.

You can specify an **Initial current I_c** value corresponding to a particular state of the circuit. In such a case all states of the linear circuit must be set accordingly. Initializing all states of a power electronic converter is a complex task. Therefore, this option is useful only with simple circuits.

Snubber resistance R_s

The snubber resistance, in ohms (Ω). Set the **Snubber resistance R_s** parameter to `inf` to eliminate the snubber from the model.

Snubber capacitance C_s

The snubber capacitance in farads (F). Set the **Snubber capacitance C_s** parameter to 0 to eliminate the snubber, or to `inf` to get a resistive snubber.

Show measurement port

If selected, add a Simulink output to the block returning the thyristor current and voltage.

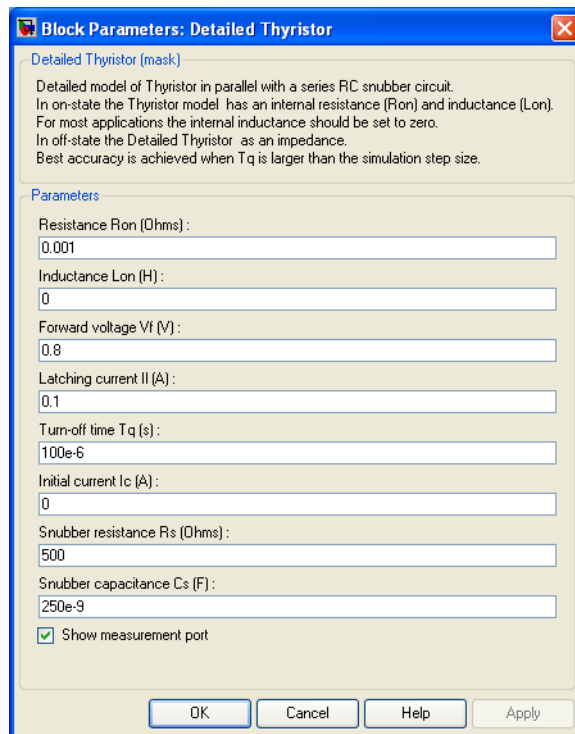

Latching current I_l

The latching current of the detailed thyristor model, in amperes (A).

Turn-off time T_q

The turnoff time T_q of the detailed thyristor model, in amperes (A).

Thyristor

Inputs and Outputs

g

Simulink signal to control the gate of the Thyristor.

m

The Simulink output of the block is a vector containing two signals. You can demultiplex these signals by using the Bus Selector block provided in the Simulink library.

Signal	Definition	Units
1	Thyristor current	A
2	Thyristor voltage	V

Assumptions and Limitations

The Thyristor block implements a macro model of the real thyristor. It does not take into account either the geometry of the device or complex physical processes that model the behavior of the device [1, 2]. The forward breakover voltage and the critical value of the derivative of the reapplied anode-cathode voltage are not considered by the model.

Depending on the value of the inductance L_{on} , the Thyristor block is modeled either as a current source ($L_{on} > 0$) or as a variable topology circuit ($L_{on} = 0$). The Thyristor block cannot be connected in series with an inductor, a current source, or an open circuit, unless its snubber circuit is in use. See Chapter 3, “Improving Simulation Performance” for more details on this topic.

Use the Powergui block to specify either continuous simulation or discretization of your electrical circuit containing Thyristor blocks. When using a continuous model, the ode23t stiff solver with a relative tolerance of $1e-4$ is recommended for best accuracy and simulation speed.

The inductance L_{on} is forced to 0 if you choose to discretize your circuit.

Example

In the `power_thyristor` demo a single-pulse thyristor rectifier is used to feed an RL load. The gate pulses are obtained from a pulse generator synchronized on the source voltage. The following parameters are used:

R	1 Ω
L	10 mH

Thyristor block:	Ron	0.001 W
	Lon	0 H
	Vf	0.8 V
	Rs	20 Ω
	Cs	4e-6 F

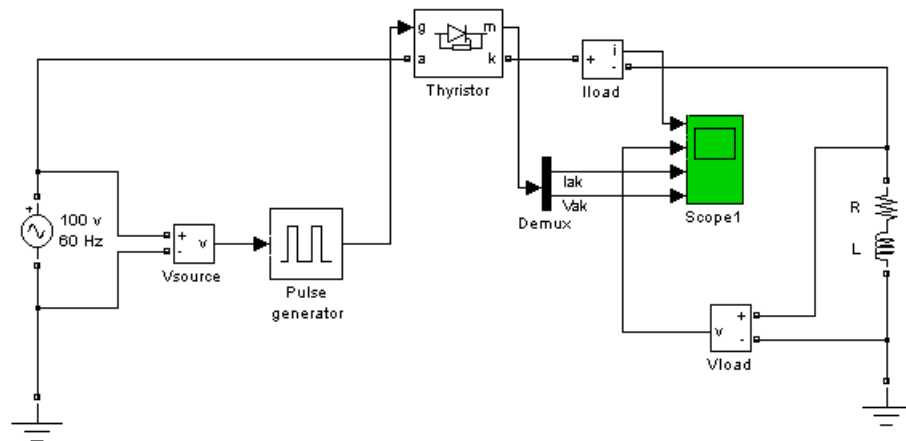

The firing angle is varied by a pulse generator synchronized on the voltage source. Run the simulation and observe the load current and load voltage, as well as the thyristor current and voltage.

Thyristor

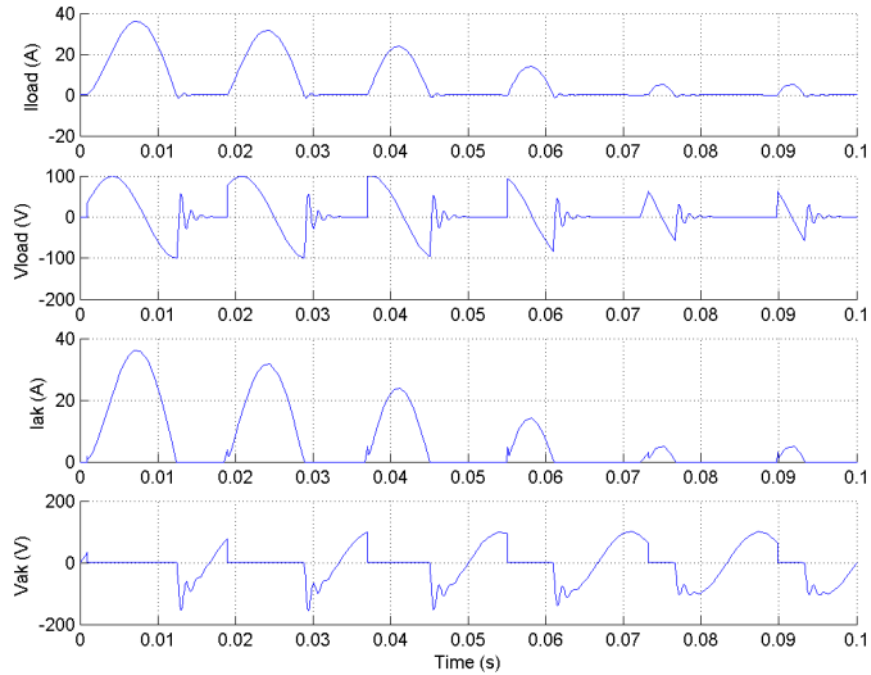

References

- [1] Rajagopalan, V., *Computer-Aided Analysis of Power Electronic Systems*, Marcel Dekker, Inc., New York, 1987.
- [2] Mohan, N., T.M. Undeland, and W.P. Robbins, *Power Electronics: Converters, Applications, and Design*, John Wiley & Sons, Inc., New York, 1995.

See Also

Diode, Universal Bridge

Purpose Generate a signal changing at specified transition times

Library Extras/Control Blocks, Extras/Discrete Control Blocks

Description The Timer block generates a signal changing at specified transition times. Use this block to generate a logical signal (0 or 1 amplitudes) and control the opening and closing times of power switches like the Breaker block and the Ideal Switch block. You can also use this block to generate a signal whose amplitude changes by steps at specified transition times.



Dialog Box and Parameters

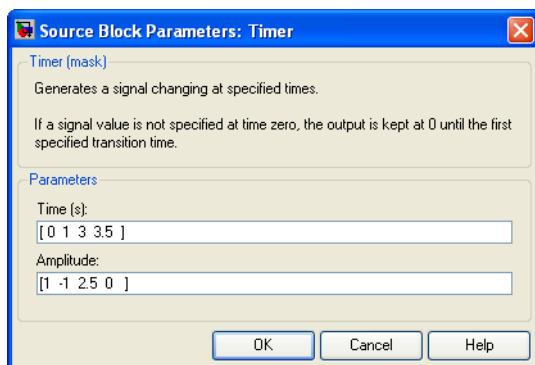

Time(s)

The transition times, in seconds, when the output of the block changes its value as defined by the **Amplitude** parameter. The **Time(s)** parameter must be a vector of the same length as the vector defined in the **Amplitude** parameter. The definition of the time 0 is optional. If a signal is not specified at time 0, the output is kept at zero until the first transition time specified in the **Amplitude** vector.

Amplitude

The vector of amplitudes of signal to be generated by the Timer block. The amplitude is kept constant between transition times defined in the **Time(s)** vector.

Inputs and Outputs

The output is a signal changing by steps at specified transition times.

Timer

Example

See the `power_breaker` model for a circuit using the Timer block to control a circuit breaker.

Purpose Measure the total harmonic distortion (THD) of a signal

Library Extras/Measurements

A discrete version of this block is available in the Extras/Discrete Measurements library.

Description



The Total Harmonic Distortion block measures the total harmonic distortion (THD) of a periodic distorted signal. The signal can be a measured voltage or current.

The THD is defined as the root mean square (RMS) value of the total harmonics of the signal, divided by the RMS value of its fundamental signal. For example, for currents, the THD is defined as

$$\text{total harmonic distortion (THD)} = \frac{I_H}{I_F}$$

where

$$I_H = \sqrt{I_2^2 + I_3^2 + \dots + I_n^2} \quad I_n: \text{RMS value of the harmonic } n$$

I_F : RMS value of the fundamental current

It follows that the THD has a value between zero and 1. It is null for a pure sinusoidal voltage or current.

Dialog Box and Parameters

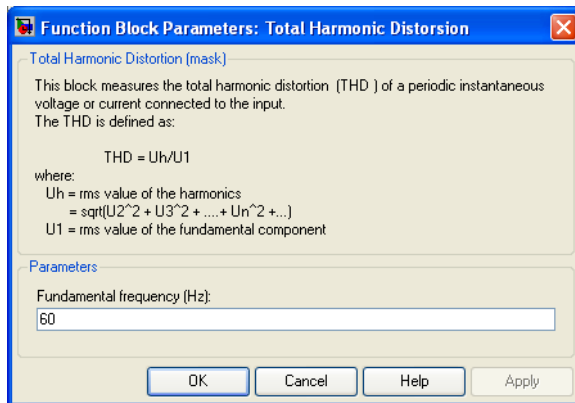

Total Harmonic Distortion

Fundamental frequency

The frequency, in hertz, of the fundamental signal.

Inputs and Outputs

signal

Connect this input to the voltage or current you want to measure the total harmonic distortion.

THD

The output returns the THD of the input signal.

Two-Quadrant Chopper DC Drive

Purpose Implement a two-quadrant chopper (buck-boost converter topology) DC drive

Library Electric Drives/DC drives

Description The high-level schematic shown below is built from four main blocks. The DC motor and the IGBT/Diode devices (within the Universal Bridge block) are provided with the SimPowerSystems library. More details on these two blocks are available in the SimPowerSystems user guide. The two other blocks are specific to the Electric Drives library. These blocks are the speed controller and the current controller. They allow speed or torque regulation. A “regulation switch” block allows you to toggle from one type of regulation to the other. During torque regulation the speed controller is disabled.

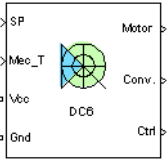

Note In SimPowerSystems, the Two-Quadrant Chopper DC Drive block is commonly called the DC6 motor drive.

High-Level Schematic

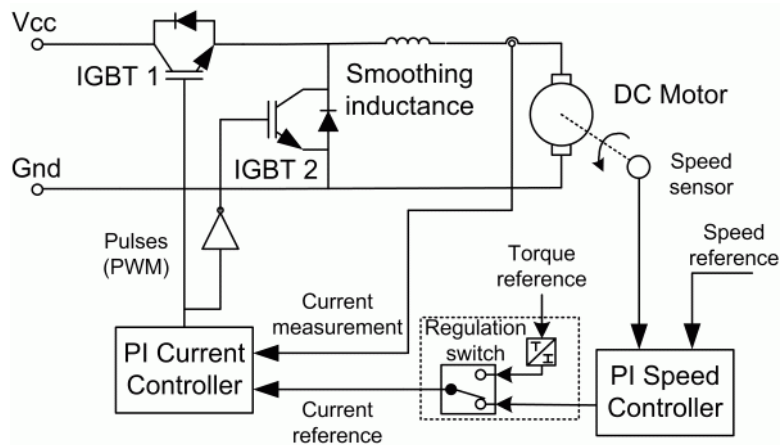

Two-Quadrant Chopper DC Drive

Simulink Schematic

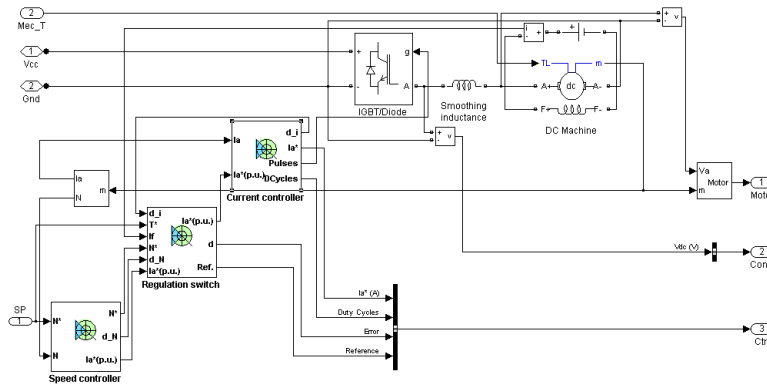

Speed Controller

The speed regulator shown below uses a PI controller. The controller outputs the armature current reference (in p.u.) used by the current controller to obtain the electromagnetic torque needed to reach the desired speed. During torque regulation, the speed controller is disabled.

The controller takes the speed reference (in rpm) and the rotor speed of the DC machine as inputs. The speed reference change rate will follow user-defined acceleration and deceleration ramps in order to avoid sudden reference changes that could cause armature over-current and destabilize the system. In order to avoid negative speeds that could induce conduction of the free-wheeling diode, the speed reference has a lower limit of 0 rpm.

The speed measurement is filtered by a first-order low-pass filter.

The current reference output is limited between symmetrical lower and upper limits defined by the user. Meanwhile, at low speeds, when the back-EMF of the motor is not high enough to generate big reverse currents, the lower limit is reduced proportionally to the speed. This improves current regulation.

Two-Quadrant Chopper DC Drive

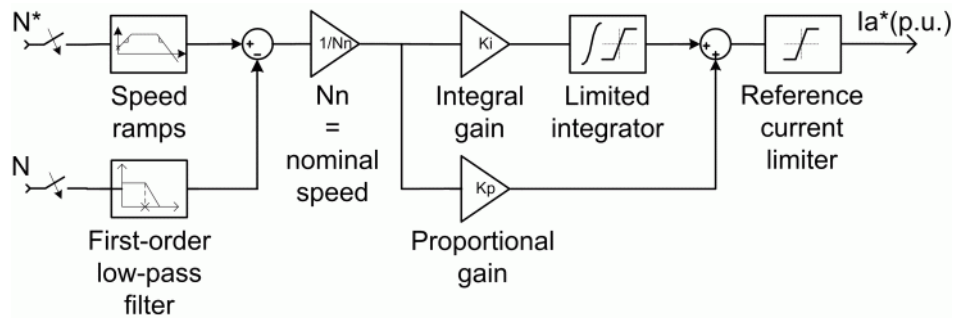

Current Controller

The armature current regulator shown below is based on a second PI controller. The regulator controls the armature current by computing the appropriate duty ratios of the fixed frequency pulses of the two IGBT devices (Pulse Width Modulation). This generates the average armature voltage needed to obtain the desired armature current and thus the desired electromagnetic torque. For proper system behavior, the two IGBT devices have opposite instantaneous pulse values.

The controller takes the current reference (in p.u.) and the armature current flowing through the motor as inputs. The current reference is either provided by the speed controller during speed regulation or computed from the torque reference provided by the user during torque regulation. This is managed by the “regulation switch” block. The armature current input is filtered by a first-order low-pass filter.

The pulse width modulation is obtained by comparison of the PI output and a fixed frequency sawtooth carrier signal (see the figure called “Pulse Width Modulation (PWM)” on page 7-636).

Two-Quadrant Chopper DC Drive

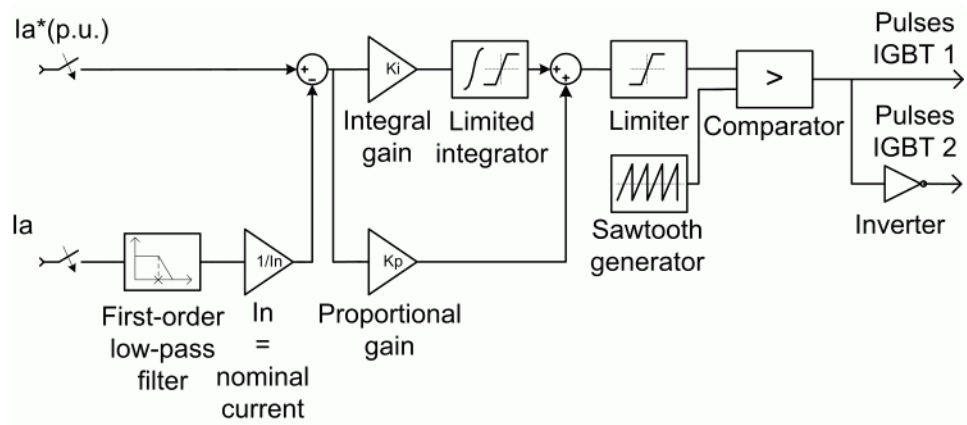

Two-Quadrant Chopper DC Drive

Average-Value Two-Quadrant Chopper

The average-value converter is shown in the following figure.

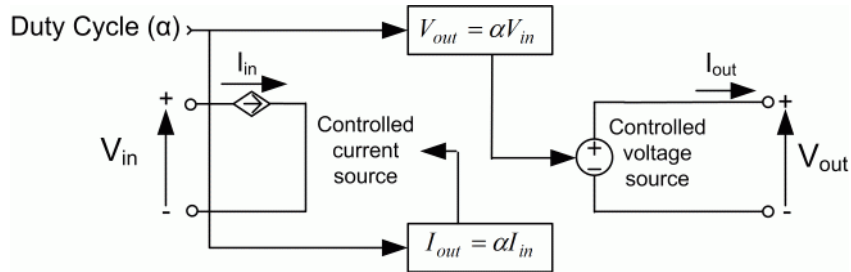

It is composed of one controlled current source on the DC source side and one controlled voltage source on the motor side. The current source allows the representation of the average input current value following the next equation:

$$I_{in} = \alpha I_{out}$$

with α being the firing angle value and I_{out} the armature current value. The voltage source on the motor side represents the average voltage value following the next equation:

$$V_{out} = \alpha V_{in}$$

with V_{in} being the input voltage.

Remarks

The machine is separately excited with a constant DC field voltage source. There is thus no field voltage control. By default, the field current is set to its steady-state value when a simulation is started.

The armature voltage is provided by an IGBT buck-boost converter controlled by two PI regulators. The converter is fed by a constant DC voltage source. Armature current oscillations are reduced by a smoothing inductance connected in series with the armature circuit.

The model is discrete. Good simulation results have been obtained with a $1 \mu\text{s}$ time step. In order to simulate a digital controller device, the control system has two different sampling times:

- The speed controller sampling time
- The current controller sampling time

Two-Quadrant Chopper DC Drive

The speed controller sampling time has to be a multiple of the current sampling time. The latter sampling time has to be a multiple of the simulation time step.

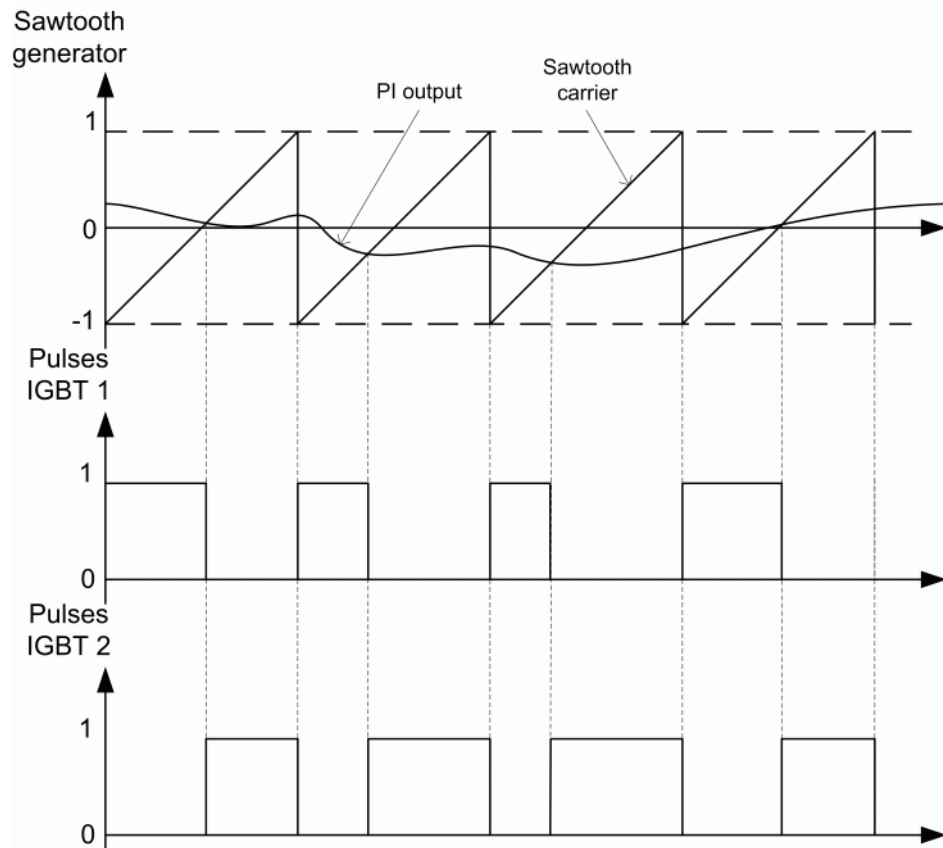

Figure 7-3: Pulse Width Modulation (PWM)

Two-Quadrant Chopper DC Drive

Dialog Box

DC Machine Tab

The screenshot shows a dialog box titled "2-Quadrant Chopper DC Motor Drive". It has three tabs: "DC Machine", "Converter", and "Controller". The "DC Machine" tab is selected. The dialog contains the following information:

The DC motor parameters are specified in the DC Machine tab. The converter parameters, smoothing inductance and field voltage values are specified in the Converter tab. The speed and current regulator parameters are specified in the Controller tab.

Electrical parameters

- Mutual inductance (H): 1.234
- Armature**
 - Resistance (ohm): 0.78
 - Inductance (H): 0.016
- Field**
 - Resistance (ohm): 150
 - Inductance (H): 112.5

Mechanical parameters

- Inertia ($\text{kg}\cdot\text{m}^2$): 0.05
- Viscous friction coefficient (N-m-s): 0.01
- Coulomb friction torque (N-m): 0
- Initial speed (rad/s): 0

Model detail level: Detailed

Parameters file options: Load Save

Buttons: OK Cancel Help Apply

The DC Machine tab displays the parameters of the DC machine block of the powerlib library. Refer to the DC Machine for more information on the DC machine block parameters.

Two-Quadrant Chopper DC Drive

Converter Tab

The screenshot shows a software window titled "2-Quadrant Chopper DC Motor Drive". The window has three tabs: "DC Machine", "Converter", and "Controller". The "Converter" tab is selected. The window contains the following sections:

- Smoothing inductance and excitation circuit:** Contains two input fields: "Smoothing inductance (H):" with the value "1e-3" and "Field DC source (V):" with the value "150".
- IGBT/Diode devices:** This section is divided into two columns:
 - Snubbers:** Contains two input fields: "Resistance (ohm):" with the value "10e3" and "Capacitance (F):" with the value "inf".
 - IGBT/Diode:** Contains several input fields:
 - "On-state resistance (ohm):" with the value "1e-3".
 - IGBT:** Contains three input fields: "Forward voltage (V):" with the value "1.3", "Current fall time (s):" with the value "0", and "Current tail time (s):" with the value "0".
 - Diode:** Contains one input field: "Forward voltage (V):" with the value "1.3".
- Model detail level:** A dropdown menu set to "Detailed".
- Parameters file options:** Contains two buttons: "Load" and "Save".

At the bottom of the window are four buttons: "OK", "Cancel", "Help", and "Apply".

IGBT/Diode Devices Section

The IGBT/Diode section of the Converter tab displays the parameters of the Universal Bridge block of the powerlib library. Refer to the Universal Bridge for more information on the Universal Bridge block parameters.

Smoothing Inductance

The smoothing inductance value (H).

Field DC Source

The DC motor field voltage value (V).

Two-Quadrant Chopper DC Drive

Controller Tab

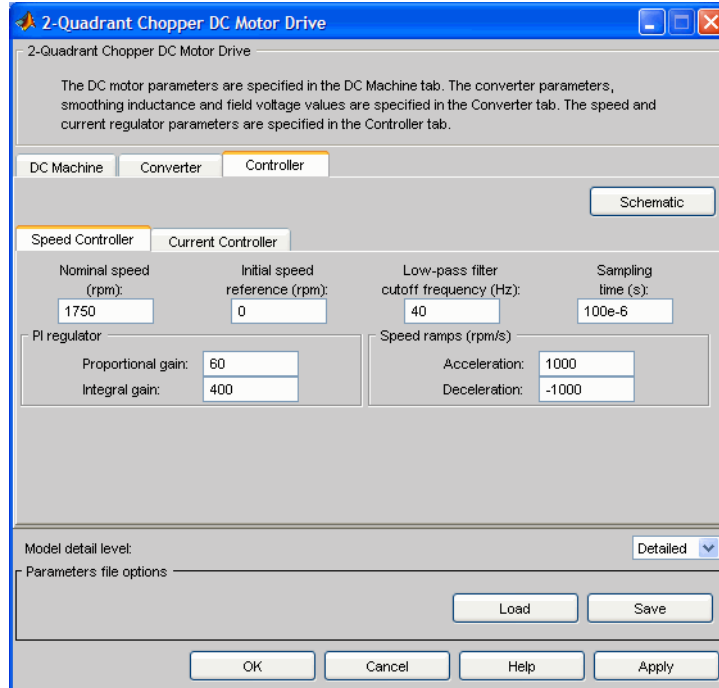

Schematic Button

When you press this button, a diagram illustrating the speed and current controllers schematics appears.

Regulation Type

This pop-up menu allows you to choose between speed and torque regulation.

Controller – Speed Controller Subtab

Nominal Speed

The nominal speed value of the DC motor (rpm). This value is used to convert motor speed from rpm to p.u. (per unit).

Two-Quadrant Chopper DC Drive

Initial Speed Reference

The initial speed reference value (rpm). This value allows the user to start a simulation with a speed reference other than 0 rpm.

Low-Pass Filter Cutoff Frequency

Cutoff frequency of the low-pass filter used to filter the motor speed measurement (Hz).

Sampling Time

The speed controller sampling time (s). This sampling time has to be a multiple of the current controller sampling time and of the simulation time step.

Proportional Gain

The proportional gain of the PI speed controller.

Integral Gain

The integral gain of the PI speed controller.

Acceleration

The maximum change of speed allowed during motor acceleration (rpm/s). Too great a value can cause armature over-current.

Deceleration

The maximum change of speed allowed during motor deceleration (rpm/s). Too great a value can cause armature over-current.

Two-Quadrant Chopper DC Drive

Controller — Current Controller Subtab

The screenshot shows a software window titled "2-Quadrant Chopper DC Motor Drive". It has three main tabs: "DC Machine", "Converter", and "Controller". The "Controller" tab is active and contains two sub-tabs: "Speed Controller" and "Current Controller". The "Current Controller" sub-tab is selected, showing the following parameters:

Parameter	Value
Low-pass filter cutoff frequency (Hz)	500
Reference limit (p.u.)	1.5
PWM switching frequency (Hz)	5e3
Sampling time (s)	20e-6
Nominal values	
Power (W)	5*746
Voltage (V)	240
PI regulator	
Proportional gain	2
Integral gain	200

At the bottom of the window, there are buttons for "OK", "Cancel", "Help", and "Apply". A "Schematic" button is also present in the top right of the Controller tab. A "Model detail level" dropdown is set to "Detailed".

Low-Pass Filter Cutoff Frequency

Cutoff frequency of the low-pass filter used to filter the armature current measurement (Hz).

Reference Limit

Symmetrical current reference (p.u.) limit around 0 p.u. 1.5 p.u. is a common value. Keep in mind that the lower limit is automatically reduced for low speeds (see speed controller description).

PWM Switching Frequency

The switching frequency of the two IGBT devices (Hz).

Two-Quadrant Chopper DC Drive

Sampling Time

The current controller sampling time (s). This sampling time has to be a submultiple of the speed controller sampling time and a multiple of the simulation time step.

Power and Voltage nominal values

The DC motor nominal power (W) and voltage (V) values. These values are used to convert armature current from amperes to p.u. (per unit).

Proportional Gain

The proportional gain of the PI current controller.

Integral Gain

The integral gain of the PI current controller.

Block Inputs and Outputs

SP

The speed or torque set point. Note that the speed set point can be a step function, but the speed change rate will follow the acceleration / deceleration ramps.

Mec_T

The mechanical load torque input. If the load torque and the speed have opposite signs, the accelerating torque will be the sum of the electromagnetic and load torques.

Vcc, Gnd

The DC voltage source electric connections. The voltage must be adequate for the motor size.

Motor

The motor measurement vector. This vector is composed of two elements:

- The armature voltage
- The DC motor measurement vector (containing the speed, armature current, field current, and electromagnetic torque values). Note that the speed signal is converted from rad/s to rpm before output.

Conv

The IGBT/Diode device measurement vector. This vector includes the converter output voltage. The output current is not included since it is

Two-Quadrant Chopper DC Drive

equal to the DC motor armature current. Note that all current and voltage values of the converter can be visualized with the multimeter block.

Ctrl

The controller measurement vector. This vector contains:

- The armature current reference
- The duty cycle of the PWM pulses
- The speed or torque error (difference between the speed reference ramp and actual speed or between the torque reference and actual torque)
- The speed reference ramp or torque reference

Model Specifications

The library contains a 5 hp and a 200 hp drive parameter set. The specifications of these two drives are shown in the following table.

5 HP and 200 HP Drive Specifications

		5 HP Drive	200 HP Drive
Drive Input Voltage			
	Amplitude	280 V	550 V
Motor Nominal Values			
	Power	5 hp	200 hp
	Speed	1750 rpm	1750 rpm
	Voltage	240 V	500 V

Example

The `dc6_example` demo illustrates the two-quadrant chopper drive used with the 200 hp drive parameter set during speed regulation. A 5 hp parameter set is also available in the library.

Two-Quadrant Chopper DC Drive

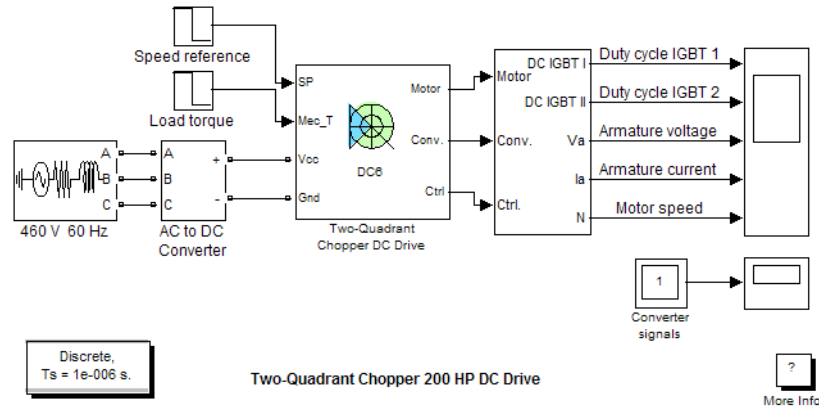

The buck-boost converter is fed by a 630 V DC bus obtained by rectification of a 460 V AC 60 Hz voltage source. In order to limit the DC bus voltage during dynamic braking mode, a braking chopper has been added between the diode rectifier and the DC6 block. The IGBT switching frequency is 5 kHz.

The speed reference is set at 400 rpm at $t = 0$ s. Initial load torque is 814 N.m.

Observe that the motor speed follows the reference ramp accurately (+250 rpm/s) and reaches steady state around $t = 2$ s. The armature current follows the current reference very well, with fast response time and small ripples. Notice that the current ripple frequency is 5 kHz.

At $t = 2.1$ s, the load torque passes from 814 N.m to 100 N.m. The motor speed recovers fast and is back at 400 rpm at $t = 2.75$ s. The current reference lowers to about 40 A to generate a smaller electromagnetic torque, the load torque being reduced. As observed before, the armature current follows its reference perfectly.

At $t = 2.75$ s, the speed reference jumps down to 100 rpm. In order for the motor to decelerate following the negative speed ramp, the armature current reverses down to -160 A to generate a braking electromagnetic torque (dynamic braking mode). This causes the DC bus voltage to increase. The braking chopper limits the voltage value.

At $t = 3.4$ s, the motor speed reaches 100 rpm and the current reverses back to 40 A.

Two-Quadrant Chopper DC Drive

At $t = 4$ s, the speed stabilizes around its reference.

The following figure shows the DC bus voltage, armature current, and speed waveforms.

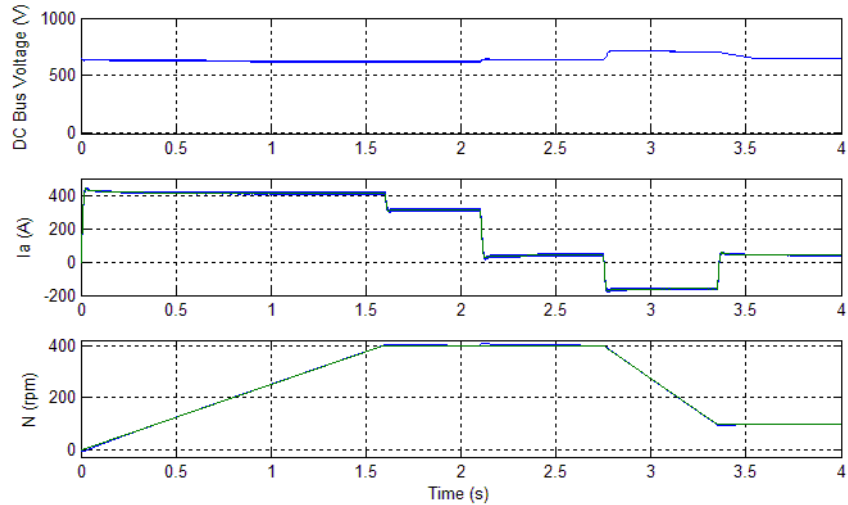

DC6 Example – DC Bus Voltage, Current, and Speed Waveforms

The next figure shows the duty cycles of the chopper pulses and the corresponding armature voltage and current waveforms during a time interval of 2 ms.

Two-Quadrant Chopper DC Drive

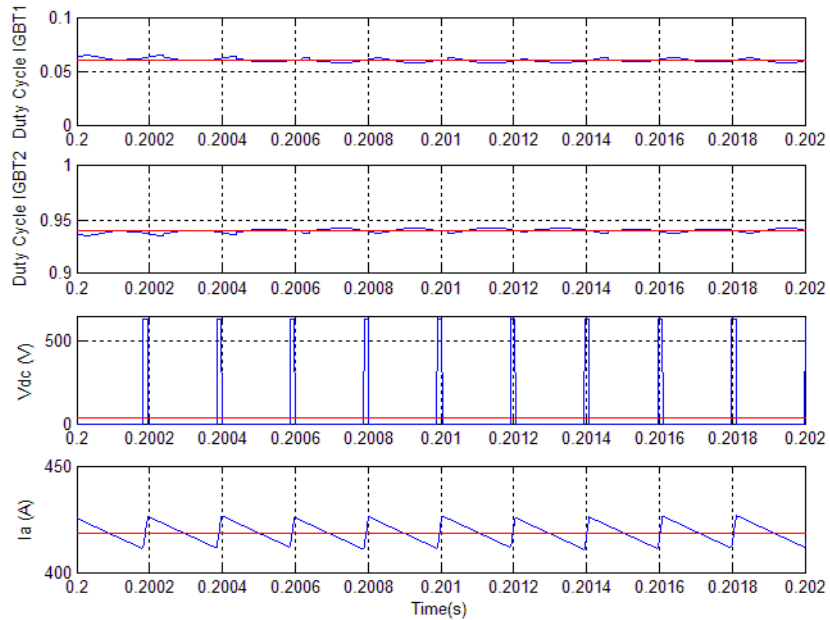

DC6 Example – Duty Cycles, Armature Voltage, and Current Waveforms

References

- [6] Boldea, Ion, and S.A. Nasar, *Electric Drives*, CRC Press LLC, 1999.
- [7] Séguier, Guy, *Electronique de puissance*, Dunod, 1999.

Two-Quadrant Single-Phase Rectifier DC Drive

Purpose

Implement a two-quadrant single-phase rectifier DC drive

Library

Electric Drives/DC drives

Description

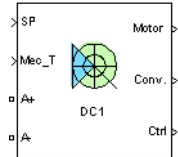

The high-level schematic shown below is built from five main blocks. The DC motor, the single-phase full converter, and the bridge firing unit are provided with the SimPowerSystems library. More details on these three blocks are available in the SimPowerSystems user guide. The two other blocks are specific to the Electric Drives library. These blocks are the speed controller and the current controller. They allow speed or torque regulation. A “regulation switch” block allows you to toggle from one type of regulation to the other. During torque regulation the speed controller is disabled. It is possible to use a simplified version of the drive containing an average-value model of the single-phase converter and allowing faster simulation.

Note In SimPowerSystems, the Two-Quadrant Single-Phase Rectifier DC Drive block is commonly called the DC1 motor drive.

High-Level Schematic

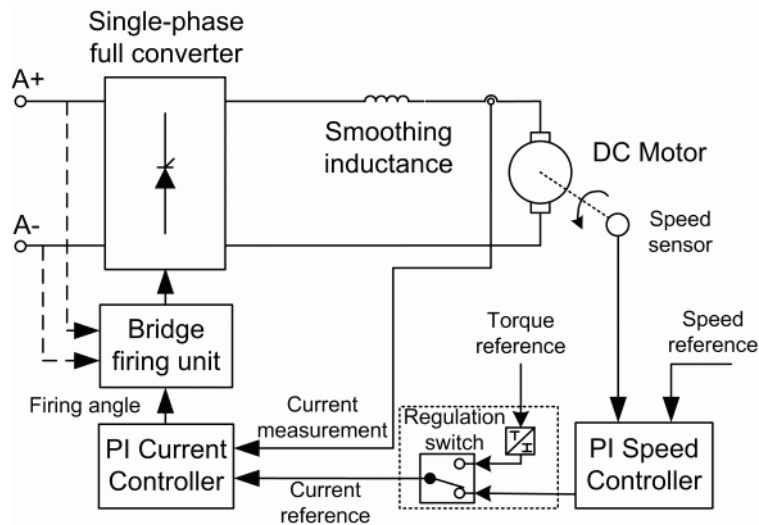

Two-Quadrant Single-Phase Rectifier DC Drive

Simulink Schematic

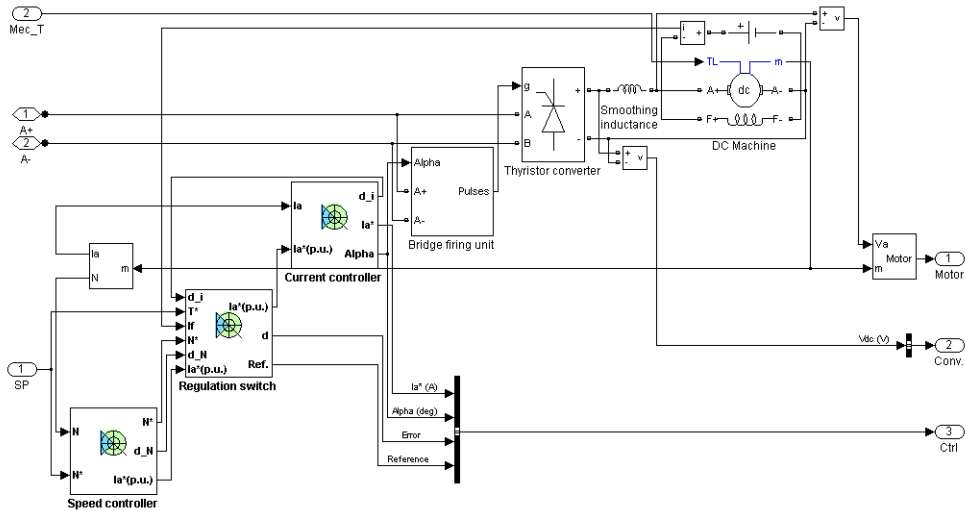

Speed Controller

The speed regulator in the following figure uses a PI controller. The controller outputs the armature current reference (in p.u.) used by the current controller in order to obtain the electromagnetic torque needed to reach the desired speed. During torque regulation, the speed controller is disabled.

The controller takes the speed reference (in rpm) and the rotor speed of the DC machine as inputs. The speed reference change rate will follow user-defined acceleration and deceleration ramps in order to avoid sudden reference changes that could cause armature over-current and destabilize the system. The speed measurement is filtered by a first-order low-pass filter.

The current reference output is limited between 0 p.u. and an upper limit defined by the user.

Two-Quadrant Single-Phase Rectifier DC Drive

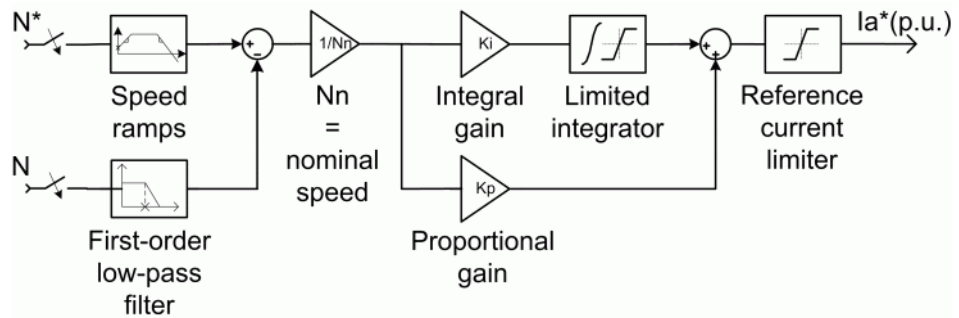

Current Controller

The armature current regulator in the following figure is based on a second PI controller. The regulator controls the armature current by computing the appropriate thyristor firing angle. This generates the rectifier output voltage needed to obtain the desired armature current and thus the desired electromagnetic torque.

The controller takes the current reference (in p.u.) and the armature current flowing through the motor as inputs. The current reference is either provided by the speed controller during speed regulation or computed from the torque reference provided by the user during torque regulation. This is managed by the “regulation switch” block.

The armature current input is filtered by a first-order low-pass filter. An arccosine function is used to linearize the control system during continuous conduction. To compensate nonlinearities appearing during discontinuous conduction, a feedforward term is added to the firing angle. This improves the system’s response time. The firing angle can vary between 0 and 180 degrees. You can limit the lower and upper limits to intermediate values.

Two-Quadrant Single-Phase Rectifier DC Drive

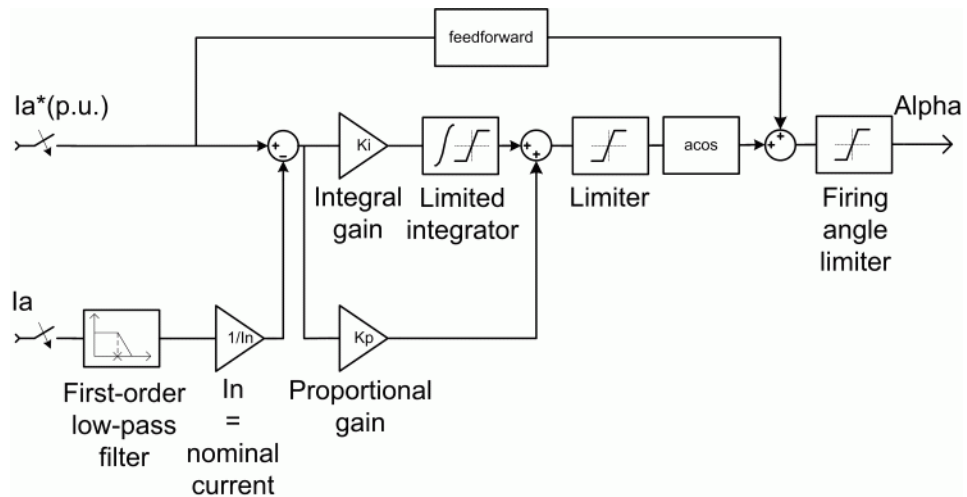

Average-Value Single-Phase Rectifier

The average-value converter is shown in the following figure.

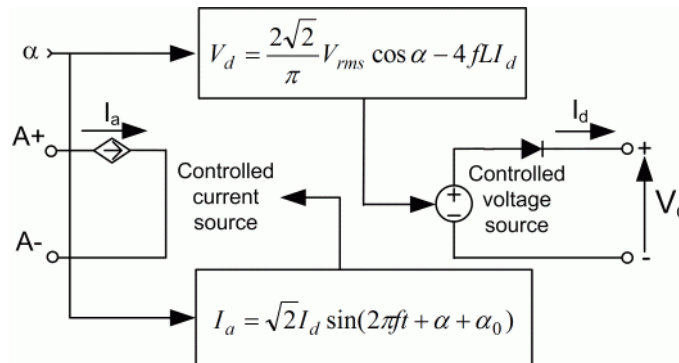

It is composed of one controlled current source on the AC side and one controlled voltage source on the DC side. The AC current source allows the representation of the fundamental single-phase current behavior following the next equation:

$$I_a = \sqrt{2} I_d \sin(2\pi f t + \alpha + \alpha_0)$$

with α being the firing angle value, α_0 the phase angle of the AC side, f the AC frequency and I_d the rectified output current value. The DC voltage source

Two-Quadrant Single-Phase Rectifier DC Drive

represents the average voltage value of the rectified voltage waveform following the next equation:

$$V_d = \frac{2\sqrt{2}}{\pi} V_{rms} \cos \alpha - 4fLI_d$$

with V_{rms} being the input RMS voltage value and L being the source inductance value.

Bridge Firing Unit

The bridge firing unit converts the firing angle, provided by the current controller, to four pulses applied to the thyristor gates. The bridge firing unit block contains a band-pass filter on voltage measurement to remove voltage harmonics. The discrete synchronized pulse generator block generates the pulses. Its architecture is based on the Discrete Synchronized 6-Pulse Generator block. Refer to the Synchronized 6-Pulse Generator for more information on this block. When using the average-value converter the bridge firing unit simply outputs the firing angle value needed by the converter.

Remarks

The machine is separately excited with a constant DC field voltage source. There is thus no field voltage control. By default, the field current is set to its steady-state value when a simulation is started.

The armature voltage is provided by a single-phase rectifier controlled by two PI regulators. Armature current oscillations are reduced by a smoothing inductance connected in series with the armature circuit.

The average-value converter represents the average behavior of a single-phase rectifier for continuous armature current. This model is thus not suitable for simulating DC drives under discontinuous armature current conditions. The converter outputs a continuous voltage value equal to the average-value of the real-life rectified voltage. The armature voltage, armature current and electromagnetic torque ripples are thus not represented. The input currents have the frequency and amplitude of the fundamental current component of the real-life input currents.

The model is discrete. Good simulation results have been obtained with a 10 μ s time step. The control system (speed and current controllers) samples data following a user-defined sample time in order to simulate a digital controller device. Keep in mind that this sampling time has to be a multiple of the simulation time step.

Two-Quadrant Single-Phase Rectifier DC Drive

The average-value converter allows the use of bigger simulation time steps since it does not generate small time constants (due to the RC snubbers) inherent to the detailed converter. For a controller sampling time of 100 μs good simulation results have been obtained for a simulation time step of 100 μs . This time step can of course not be higher than the controller time step.

Two-Quadrant Single-Phase Rectifier DC Drive

Dialog Box

DC Machine Tab

The dialog box is titled "2-Quadrant Single-Phase Rectifier DC Motor Drive". It contains a text area at the top explaining that DC motor parameters are in the DC Machine tab, converter parameters are in the Converter tab, and bridge firing unit, speed, and current regulator parameters are in the Controller tab. Below this are three tabs: "DC Machine" (selected), "Converter", and "Controller".

The "DC Machine" tab is divided into two columns: "Electrical parameters" and "Mechanical parameters".

Electrical parameters:

- Mutual inductance (H): 1.234
- Armature:**
 - Resistance (ohm): 0.78
 - Inductance (H): 0.016
- Field:**
 - Resistance (ohm): 150
 - Inductance (H): 112.5

Mechanical parameters:

- Inertia ($\text{kg}\cdot\text{m}^2$): 0.05
- Viscous friction coefficient (N-m-s): 0.01
- Coulomb friction torque (N-m): 0
- Initial speed (rad/s): 0

At the bottom, there is a "Model detail level" dropdown set to "Detailed", a "Parameters file options" section with "Load" and "Save" buttons, and a row of "OK", "Cancel", "Help", and "Apply" buttons.

The DC Machine tab displays the parameters of the DC machine block of the powerlib library. Refer to the DC Machine for more information on the DC machine block parameters.

Two-Quadrant Single-Phase Rectifier DC Drive

Converter Tab

The screenshot shows a software window titled "2-Quadrant Single-Phase Rectifier DC Motor Drive". The window contains a text box at the top explaining that DC motor parameters are in the DC Machine tab, converter parameters are in the Converter tab, and bridge firing, speed, and current regulator parameters are in the Controller tab. Below this is a tabbed interface with three tabs: "DC Machine", "Converter" (which is selected), and "Controller".

The "Converter" tab is divided into several sections:

- Rectifier:**
 - Snubbers:** Resistance (ohm): 2e3, Capacitance (F): 500e-9.
 - Thyristors:** On-state resistance (ohm): 1e-3, Forward voltage (V): 1.3.
- DC bus and Excitation circuit:** Smoothing inductance (H): 150e-3, Field DC source (V): 150.
- External Voltage Source:** RMS voltage (V): 320, Frequency (Hz): 50, Source inductance (H): 0.1e-3, Phase angle (deg): 0.

At the bottom of the window, there is a "Model detail level" dropdown menu set to "Average", a "Parameters file options" section with "Load" and "Save" buttons, and a row of four buttons: "OK", "Cancel", "Help", and "Apply".

Rectifier section

The Rectifier section of the Converter tab displays the parameters of the Universal Bridge block of the powerlib library. Refer to the Universal Bridge for more information on the Universal Bridge block parameters.

Smoothing Inductance

The smoothing inductance value (H).

Field DC Source

The DC motor field voltage value (V).

RMS Voltage

RMS voltage of the single-phase voltage source connected to the A+,A- terminals of the drive (V). This parameter is not used when using the detailed rectifier.

Two-Quadrant Single-Phase Rectifier DC Drive

Frequency

Frequency of the single-phase voltage source connected to the A+,A- terminals of the drive (Hz). This parameter is not used when using the detailed rectifier.

Source Inductance

Source inductance of the single-phase voltage source connected to the A+,A- terminals of the drive (H). This parameter is not used when using the detailed rectifier.

Phase Angle

Phase angle of the single-phase voltage source connected to the A+,A- terminals of the drive (deg.). This parameter is not used when using the detailed rectifier.

Controller Tab

The screenshot shows the 'Controller' tab of the '2-Quadrant Single-Phase Rectifier DC Motor Drive' software. The interface includes a title bar, a main window with a description, and several control panels. The 'Regulation type' is set to 'Speed regulation' with a 'Sampling time (s)' of '100e-6'. The 'Speed Controller' sub-tab is active, showing 'Nominal speed (rpm)' at 1750, 'Initial speed reference (rpm)' at 0, and 'Low-pass filter cutoff frequency (Hz)' at 40. The 'PI regulator' section has 'Proportional gain' at 10 and 'Integral gain' at 50. The 'Speed ramps (rpm/s)' section has 'Acceleration' at 1000 and 'Deceleration' at -1000. At the bottom, there are 'Load' and 'Save' buttons, and a 'Model detail level' dropdown set to 'Detailed'. The main window also contains 'OK', 'Cancel', 'Help', and 'Apply' buttons.

2-Quadrant Single-Phase Rectifier DC Motor Drive

The DC motor parameters are specified in the DC Machine tab. The converter parameters, smoothing inductance and field voltage values are specified in the Converter tab. The bridge firing unit, speed and current regulator parameters are specified in the Controller tab.

DC Machine Converter **Controller**

Regulation type: Speed regulation Sampling time (s): 100e-6 Schematic

Speed Controller Current Controller Bridge Firing Unit

Nominal speed (rpm): 1750 Initial speed reference (rpm): 0 Low-pass filter cutoff frequency (Hz): 40

PI regulator

Proportional gain: 10 Integral gain: 50

Speed ramps (rpm/s)

Acceleration: 1000 Deceleration: -1000

Model detail level: Detailed

Parameters file options

Load Save

OK Cancel Help Apply

Two-Quadrant Single-Phase Rectifier DC Drive

Schematic Button

When you press this button, a diagram illustrating the speed and current controllers schematics appears.

Regulation Type

This pop-up menu allows you to choose between speed and torque regulation.

Sampling Time

The controller (speed and current) sampling time (s). The sampling time has to be a multiple of the simulation time step.

Controller — Speed Controller Subtab

Nominal Speed

The nominal speed value of the DC motor (rpm). This value is used to convert motor speed from rpm to p.u. (per unit).

Initial Speed Reference

The initial speed reference value (rpm). This value allows the user to start a simulation with a speed reference other than 0 rpm.

Low-Pass Filter Cutoff Frequency

Cutoff frequency of the low-pass filter used to filter the motor speed measurement (Hz).

Proportional Gain

The proportional gain of the PI speed controller.

Integral Gain

The integral gain of the PI speed controller.

Acceleration

The maximum change of speed allowed during motor acceleration (rpm/s). Too great a value can cause armature over-current.

Deceleration

The maximum change of speed allowed during motor deceleration (rpm/s). Too great a value can cause armature over-current.

Two-Quadrant Single-Phase Rectifier DC Drive

Controller — Current Controller Subtab

2-Quadrant Single-Phase Rectifier DC Motor Drive

The DC motor parameters are specified in the DC Machine tab. The converter parameters, smoothing inductance and field voltage values are specified in the Converter tab. The bridge firing unit, speed and current regulator parameters are specified in the Controller tab.

DC Machine Converter **Controller**

Regulation type: Speed regulation Sampling time (s): 100e-6 Schematic

Speed Controller **Current Controller** Bridge Firing Unit

Low-pass filter cutoff frequency (Hz): 50 Reference limit (p.u.): 1.5

Nominal values

Power (W):	5746	PI regulator	Proportional gain:	1
Voltage (V):	240		Integral gain:	80

Model detail level: Detailed

Parameters file options

Load Save

OK Cancel Help Apply

Power and Voltage nominal values

The DC motor nominal power (W) and voltage (V) values. These values are used to convert armature current values from amperes to p.u. (per unit).

Proportional Gain

The proportional gain of the PI current controller.

Integral Gain

The integral gain of the PI current controller.

Low-Pass Filter Cutoff Frequency

Cutoff frequency of the low-pass filter used to filter the armature current measurement (Hz).

Reference Limit

Maximum current reference value (p.u.). 1.5 p.u. is a common value.

Two-Quadrant Single-Phase Rectifier DC Drive

Controller — Bridge Firing Unit Subtab

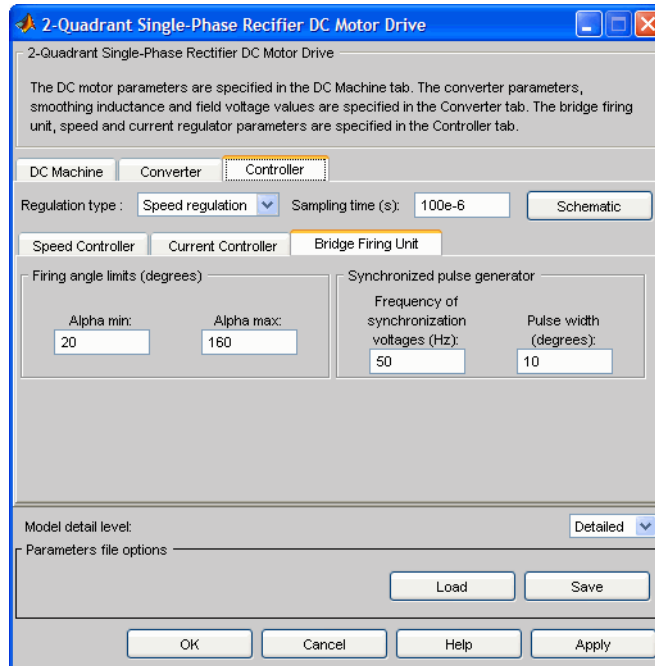

Alpha Min

Minimum firing angle value (deg.). 20 degrees is a common value.

Alpha Max

Maximum firing angle value (deg.). 160 degrees is a common value.

Two-Quadrant Single-Phase Rectifier DC Drive

Frequency of Synchronization Voltages

Frequency of the synchronization voltages used by the discrete synchronized pulse generator block (Hz). This frequency is equal to the line frequency of the single-phase power line. This parameter is not used when using the average-value converter.

Pulse Width

The width of the pulses applied to the four thyristor gates (deg.). This parameter is not used when using the average-value converter.

Block Inputs and Outputs

SP

The speed or torque set point. Note that the speed set point can be a step function, but the speed change rate will follow the acceleration / deceleration ramps.

Mec_T

The mechanical load torque input. If the load torque and the speed have opposite signs, the accelerating torque will be the sum of the electromagnetic and load torques.

A+, A-

The single-phase electric connections. The applied voltage must be adequate for the motor size.

Motor

The motor measurement vector. This vector is composed of two elements:

- The armature voltage
- The DC motor measurement vector (containing the speed, armature current, field current, and electromagnetic torque values). Note that the speed signal is converted from rad/s to rpm before output.

Conv

The single-phase converter measurement vector. It includes the converter output voltage. The output current is not included since it is equal to the DC motor armature current.

Note that all current and voltage values of the bridges can be visualized with the Multimeter block.

Two-Quadrant Single-Phase Rectifier DC Drive

Ctrl

The controller measurement vector. This vector contains:

- The armature current reference
- The firing angle computed by the current controller
- The speed or torque error (difference between the speed reference ramp and actual speed or between the torque reference and actual torque)
- The speed reference ramp or torque reference

Model Specifications

The library contains a 5 hp drive parameter set. The specifications of the 5 hp drive are shown in the following table.

5 HP Drive Specifications

Drive Input Voltage		
Amplitude		320 V
Frequency		50 Hz
Motor Nominal Values		
Power		5 hp
Speed		1750 rpm
Voltage		240 V

Example

The `dc1_example` demo illustrates the single-phase rectifier drive used with the 5 hp drive parameter set during speed regulation.

Two-Quadrant Single-Phase Rectifier DC Drive

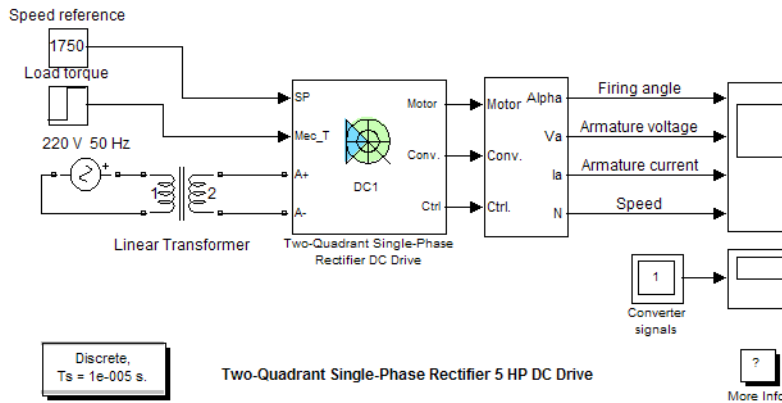

The rectifier is fed by a 220 V AC 50 Hz voltage source followed by a linear transformer to boost the voltage to a sufficient value.

The speed reference is set at 1750 rpm at $t = 0$ s. Initial load torque is 15 N.m.

Observe that the motor speed follows the reference ramp accurately (+250 rpm/s) and reaches steady state around $t = 8.5$ s.

The armature current follows the current reference very well, and the firing angle stays below 90 degrees, the converter being in rectifier mode (first quadrant operating mode). The lower limit of the firing angle has been set to 20 degrees.

At $t = 8.75$ s, the load torque passes from 15 N.m to 20 N.m. The motor speed recovers fast and is back at 1750 rpm at $t = 10$ s. The current reference rises to about 17.5 A to generate a higher electromagnetic torque to maintain the needed speed. As observed before, the armature current follows its reference perfectly.

The following figure illustrates the results obtained respectively with the detailed and the average-value converters. Average voltage, current, torque and speed values are identical for both models. The average firing angle values however are slightly different. Notice that the higher frequency signal components are not represented with the average-value converter.

Two-Quadrant Single-Phase Rectifier DC Drive

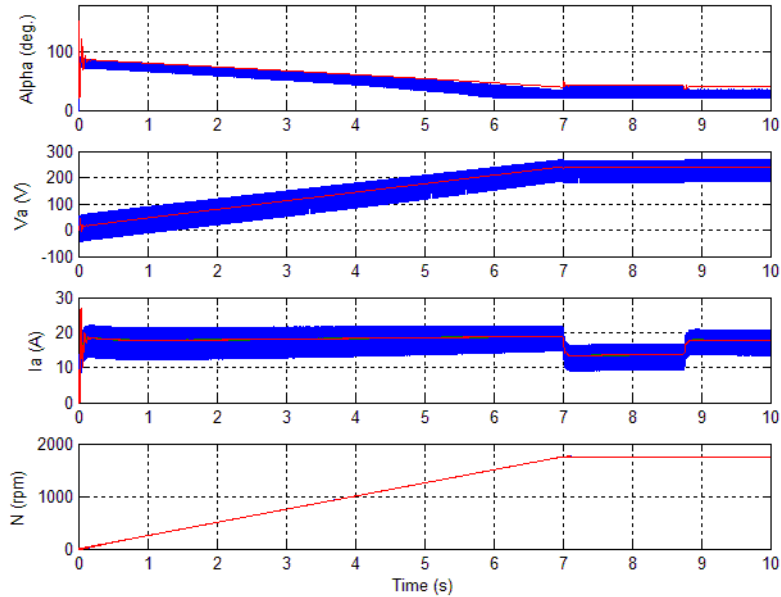

DC1 Example Waveforms (Blue : Detailed Converter, Red : Average-Value Converter)

References

- [1] Sen, P.C., *Thyristor DC Drives*, J.Wiley and Sons, 1981.
- [2] Nondahl, Thomas A., *Microprocessor Control of Motor Drives and Power Converters, tutorial course*, IEEE Industry Application Society, October 1993, pp. 7.1-7.26.

Two-Quadrant Three-Phase Rectifier DC Drive

Purpose

Implement a two-quadrant three-phase rectifier DC drive

Library

Electric Drives/DC drives

Description

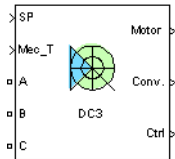

The high-level schematic shown below is built from five main blocks. The DC motor, the three-phase full converter, and the bridge firing unit are provided with the SimPowerSystems library. More details on these three blocks are available in the SimPowerSystems user guide. The two other blocks are specific to the Electric Drives library. These blocks are the speed controller and the current controller. They allow speed or torque regulation. A “regulation switch” block allows you to toggle from one type of regulation to the other. During torque regulation the speed controller is disabled. It is possible to use a simplified version of the drive containing an average-value model of the three-phase converter and allowing faster simulation.

Note In SimPowerSystems, the Two-Quadrant Three-Phase Rectifier DC Drive block is commonly called the DC3 motor drive.

High-Level Schematic

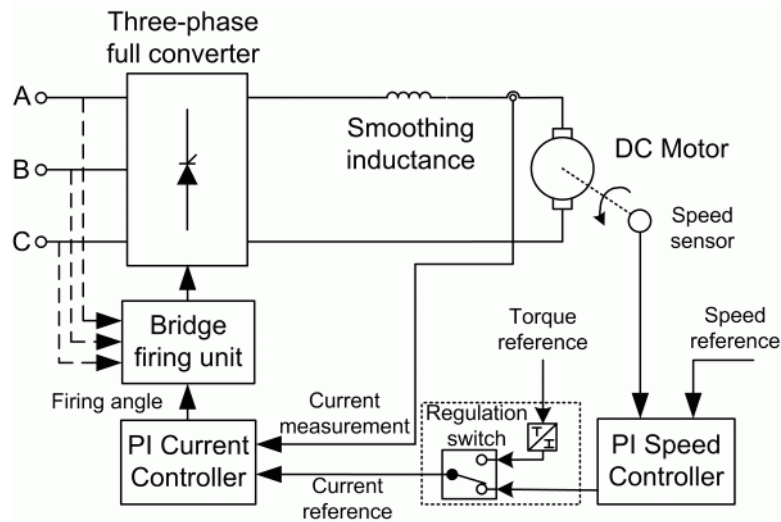

Two-Quadrant Three-Phase Rectifier DC Drive

Simulink Schematic

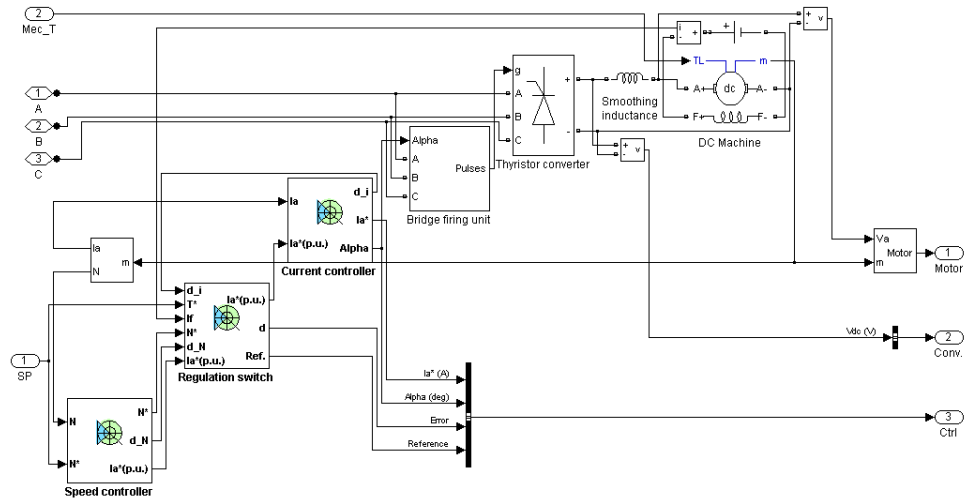

Speed Controller

The speed regulator shown below uses a PI controller. The controller outputs the armature current reference (in p.u.) used by the current controller in order to obtain the electromagnetic torque needed to reach the desired speed. During torque regulation, the speed controller is disabled.

The controller takes the speed reference (in rpm) and the rotor speed of the DC machine as inputs. The speed reference change rate will follow user-defined acceleration and deceleration ramps in order to avoid sudden reference changes that could cause armature over-current and destabilize the system. The speed measurement is filtered by a first-order low-pass filter.

The current reference output is limited between 0 p.u. and an upper limit defined by the user.

Two-Quadrant Three-Phase Rectifier DC Drive

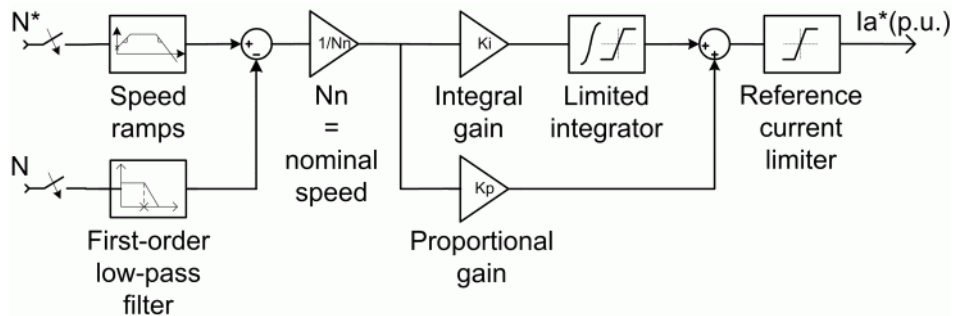

Current Controller

The armature current regulator shown below is based on a second PI controller. The regulator controls the armature current by computing the appropriate thyristor firing angle. This generates the rectifier output voltage needed to obtain the desired armature current and thus the desired electromagnetic torque.

The controller takes the current reference (in p.u.) and the armature current flowing through the motor as inputs. The current reference is either provided by the speed controller during speed regulation or computed from the torque reference provided by the user during torque regulation. This is managed by the “regulation switch” block.

The armature current input is filtered by a first-order low-pass filter. An arccosine function is used to linearize the control system during continuous conduction. To compensate nonlinearities appearing during discontinuous conduction, a feedforward term is added to the firing angle. This improves the system’s response time. The firing angle can vary between 0 and 180 degrees. You can limit the lower and upper limits to intermediate values.

Two-Quadrant Three-Phase Rectifier DC Drive

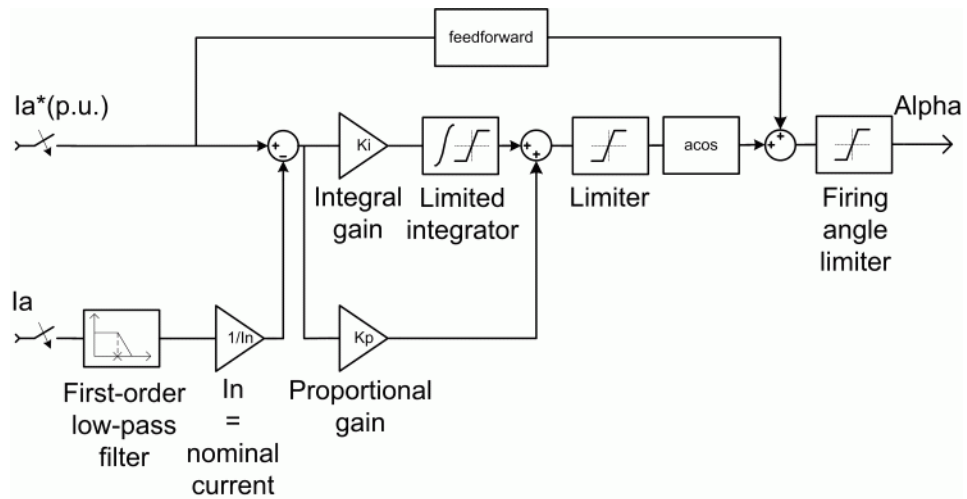

Average-Value Three-phase Rectifier

The simplified converter is shown in the following figure.

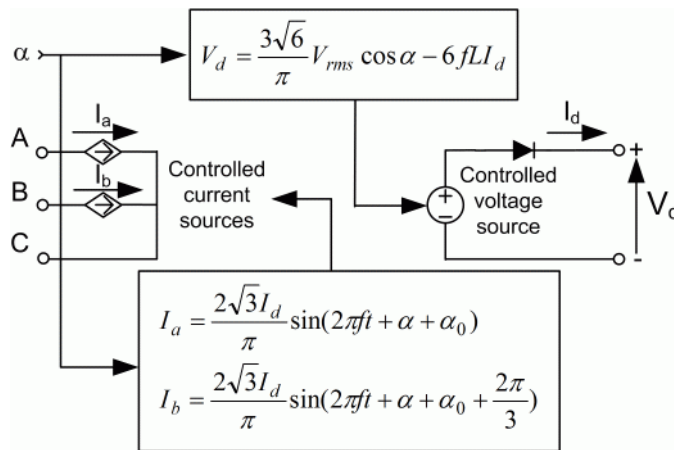

It is composed of two controlled current sources on the AC side and one controlled voltage source on the DC side. The AC current sources allow the representation of the fundamental three-phase current behaviors following the next equations:

Two-Quadrant Three-Phase Rectifier DC Drive

$$I_a = \frac{2\sqrt{3}}{\pi} I_d \sin(2\pi ft + \alpha + \alpha_0)$$

$$I_b = \frac{2\sqrt{3}}{\pi} I_d \sin\left(2\pi ft + \alpha + \alpha_0 + \frac{2\pi}{3}\right)$$

with α being the firing angle value, α_0 the phase angle of phase A, f the AC frequency and I_d the rectified output current value. The DC voltage source represents the average voltage value of the rectified voltage waveform following the next equation:

$$V_d = \frac{3\sqrt{6}}{\pi} V_{rms} \cos \alpha - 6fLI_d$$

with V_{rms} being the input phase-to-phase RMS voltage value and L being the source inductance value.

Bridge Firing Unit

The bridge firing unit converts the firing angle, provided by the current controller, to six pulses applied to the thyristor gates. The bridge firing unit block contains a band-pass filter on voltage measurement to remove voltage harmonics. The Discrete Synchronized 6-Pulse Generator block generates the pulses. Refer to the Synchronized 6-Pulse Generator for more information on this block. When using the average-value converter the bridge firing unit simply outputs the firing angle value needed by the converter.

Remarks

The machine is separately excited with a constant DC field voltage source. There is thus no field voltage control. By default, the field current is set to its steady-state value when a simulation is started.

The armature voltage is provided by a three-phase rectifier controlled by two PI regulators. Armature current oscillations are reduced by a smoothing inductance connected in series with the armature circuit.

The average-value converter represents the average behavior of a three-phase rectifier for continuous armature current. This model is thus not suitable for simulating DC drives under discontinuous armature current conditions. The converter outputs a continuous voltage value equal to the average-value of the real-life rectified voltage. The armature voltage, armature current and electromagnetic torque ripples are thus not represented. The input currents have the frequency and amplitude of the fundamental current component of the real-life input currents.

Two-Quadrant Three-Phase Rectifier DC Drive

The model is discrete. Good simulation results have been obtained with a $5\ \mu\text{s}$ time step. The control system (speed and current controllers) samples data following a user-defined sample time in order to simulate a digital controller device. Keep in mind that this sampling time has to be a multiple of the simulation time step.

The average-value converter allows the use of bigger simulation time steps since it does not generate small time constants (due to the RC snubbers) inherent to the detailed converter. For a controller sampling time of $100\ \mu\text{s}$ good simulation results have been obtained for a simulation time step of $100\ \mu\text{s}$. This time step can of course not be higher than the controller time step.

Two-Quadrant Three-Phase Rectifier DC Drive

Dialog Box

DC Machine Tab

The screenshot shows a software dialog box titled "2-Quadrant Three-Phase Rectifier DC Motor Drive". It features three tabs: "DC Machine" (selected), "Converter", and "Controller". A text box at the top explains that DC motor parameters are in the DC Machine tab, converter parameters and field voltage values are in the Converter tab, and bridge firing unit, speed, and current regulator parameters are in the Controller tab.

The "DC Machine" tab is divided into two main sections: "Electrical parameters" and "Mechanical parameters".

Electrical parameters:

- Mutual inductance (H): 1.234
- Armature:**
 - Resistance (ohm): 0.78
 - Inductance (H): 0.016
- Field:**
 - Resistance (ohm): 150
 - Inductance (H): 112.5

Mechanical parameters:

- Inertia (kg·m²): 0.05
- Viscous friction coefficient (N·m·s): 0.01
- Coulomb friction torque (N·m): 0
- Initial speed (rad/s): 0

At the bottom, there is a "Model detail level" dropdown menu set to "Average", and "Parameters file options" with "Load" and "Save" buttons. The dialog box concludes with "OK", "Cancel", "Help", and "Apply" buttons.

The DC Machine tab displays the parameters of the DC machine block of the powerlib library. Refer to the DC Machine for more information on the DC machine block parameters.

Two-Quadrant Three-Phase Rectifier DC Drive

Converter Tab

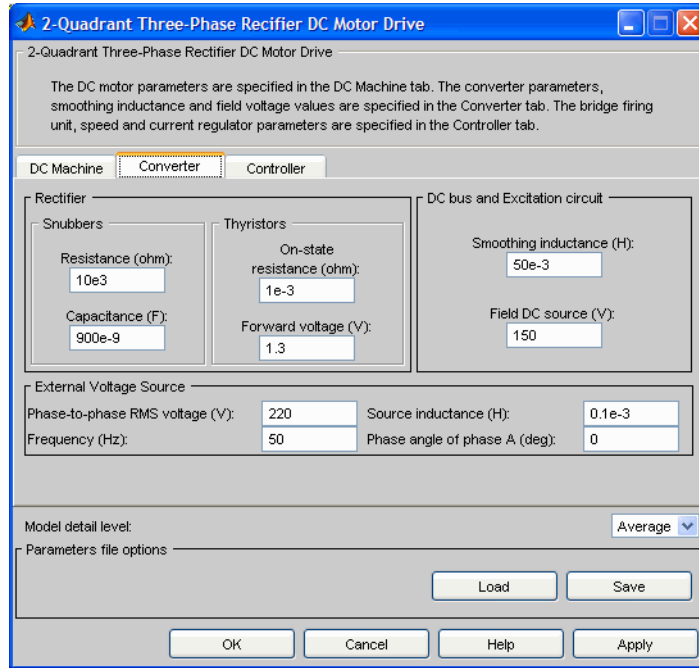

Rectifier section

The Rectifier section of the Converter tab displays the parameters of the Universal Bridge block of the powerlib library. Refer to the Universal Bridge for more information on the thyristor converter parameters.

Smoothing Inductance

The smoothing inductance value (H).

Field DC Source

The DC motor field voltage value (V).

Phase-to-Phase RMS Voltage

Phase-to-phase rms voltage of the three-phase voltage source connected to the A,B,C terminals of the drive (V). This parameter is not used when using the detailed rectifier.

Two-Quadrant Three-Phase Rectifier DC Drive

Frequency

Frequency of the three-phase voltage source connected to the A,B,C terminals of the drive (Hz). This parameter is not used when using the detailed rectifier.

Source Inductance

Source inductance of the three-phase voltage source connected to the A,B,C terminals of the drive (H). This parameter is not used when using the detailed rectifier.

Phase Angle of Phase A

Phase angle of phase A of the three-phase voltage source connected to the A,B,C terminals of the drive (deg). This parameter is not used when using the detailed rectifier.

Controller Tab

The screenshot shows the '2-Quadrant Three-Phase Rectifier DC Motor Drive' software window. The 'Controller' tab is selected, and the 'Speed Controller' sub-tab is active. The interface includes a text box with instructions, a 'Regulation type' dropdown set to 'Speed regulation', and a 'Sampling time (s)' field set to '100e-6'. The 'Speed Controller' section contains fields for 'Nominal speed (rpm)' (1750), 'Initial speed reference (rpm)' (0), and 'Low-pass filter cutoff frequency (Hz)' (40). The 'PI regulator' section has 'Proportional gain' (10) and 'Integral gain' (50). The 'Speed ramps (rpm/s)' section has 'Acceleration' (1000) and 'Deceleration' (-1000). At the bottom, there are 'Load' and 'Save' buttons, and a 'Model detail level' dropdown set to 'Average'. The 'Parameters file options' section is empty.

Parameter	Value
Regulation type	Speed regulation
Sampling time (s)	100e-6
Nominal speed (rpm)	1750
Initial speed reference (rpm)	0
Low-pass filter cutoff frequency (Hz)	40
Proportional gain	10
Integral gain	50
Acceleration (rpm/s)	1000
Deceleration (rpm/s)	-1000

Two-Quadrant Three-Phase Rectifier DC Drive

Schematic Button

When you press this button, a diagram illustrating the speed and current controllers schematics appears.

Regulation Type

This pop-up menu allows you to choose between speed and torque regulation.

Sampling Time

The controller (speed and current) sampling time (s). The sampling time has to be a multiple of the simulation time step.

Controller — Speed Controller Subtab

Nominal Speed

The nominal speed value of the DC motor (rpm). This value is used to convert motor speed from rpm to p.u. (per unit).

Initial Speed Reference

The initial speed reference value (rpm). This value allows the user to start a simulation with a speed reference other than 0 rpm.

Low-Pass Filter Cutoff Frequency

Cutoff frequency of the low-pass filter used to filter the motor speed measurement (Hz).

Proportional Gain

The proportional gain of the PI speed controller.

Integral Gain

The integral gain of the PI speed controller.

Acceleration

The maximum change of speed allowed during motor acceleration (rpm/s). Too great a value can cause armature over-current.

Deceleration

The maximum change of speed allowed during motor deceleration (rpm/s). Too great a value can cause armature over-current.

Two-Quadrant Three-Phase Rectifier DC Drive

Controller — Current Controller Subtab

The screenshot shows a software window titled "2-Quadrant Three-Phase Rectifier DC Motor Drive". The window has three tabs: "DC Machine", "Converter", and "Controller". The "Controller" tab is active. Below the tabs, there is a "Regulation type" dropdown menu set to "Speed regulation" and a "Sampling time (s)" input field set to "100e-6". A "Schematic" button is located to the right. Below this, there are three sub-tabs: "Speed Controller", "Current Controller", and "Bridge Firing Unit". The "Current Controller" sub-tab is active. It contains several input fields: "Low-pass filter cutoff frequency (Hz)" set to "120", "Reference limit (p.u.)" set to "1.5", "Nominal values" section with "Power (W)" set to "5746" and "Voltage (V)" set to "240", and "PI regulator" section with "Proportional gain" set to "1.1" and "Integral gain" set to "90". At the bottom, there is a "Model detail level" dropdown set to "Average" and a "Parameters file options" section with "Load" and "Save" buttons. At the very bottom of the window are "OK", "Cancel", "Help", and "Apply" buttons.

Power and Voltage nominal values

The DC motor nominal power (W) and voltage (V) values. These values are used to convert armature current from amperes to p.u. (per unit).

Proportional Gain

The proportional gain of the PI current controller.

Integral Gain

The integral gain of the PI current controller.

Low-Pass Filter Cutoff Frequency

Cutoff frequency of the low-pass filter used to filter the armature current measurement (Hz).

Reference Limit

Maximum current reference value (p.u.). 1.5 p.u. is a common value.

Two-Quadrant Three-Phase Rectifier DC Drive

Controller — Bridge Firing Unit Subtab

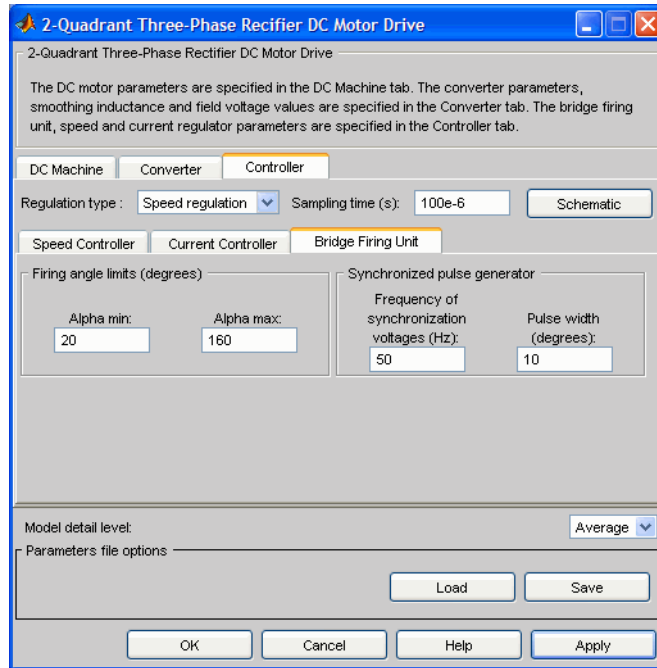

Alpha Min

Minimum firing angle value (deg.). 20 degrees is a common value.

Alpha Max

Maximum firing angle value (deg.). 160 degrees is a common value.

Frequency of synchronization voltages

Frequency of the synchronization voltages used by the discrete synchronized 6-pulse generator block (Hz). This frequency is equal to the line frequency of the three-phase power line. This parameter is not used when using the average-value converter.

Pulse Width

The width of the pulses applied to the six thyristor gates (deg.). This parameter is not used when using the average-value converter.

Two-Quadrant Three-Phase Rectifier DC Drive

Block Inputs and Outputs

SP

The speed or torque set point. Note that the speed set point can be a step function, but the speed change rate will follow the acceleration / deceleration ramps.

Mec_T

The mechanical load torque input. If the load torque and the speed have opposite signs, the accelerating torque will be the sum of the electromagnetic and load torques.

A, B, C

The three-phase electric connections. The voltage must be adequate for the motor size.

Motor

The motor measurement vector. This vector is composed of two elements:

- The armature voltage
- The DC motor measurement vector (containing the speed, armature current, field current, and electromagnetic torque values). Note that the speed signal is converted from rad/s to rpm before output.

Conv

The three-phase converter measurement vector. It includes the converter output voltage. The output current is not included since it is equal to the DC motor armature current. Note that all current and voltage values of the detailed rectifier bridge can be visualized with the multimeter block

Ctrl

The controller measurement vector. This vector contains:

- The armature current reference
- The firing angle computed by the current controller
- The speed or torque error (difference between the speed reference ramp and actual speed or between the torque reference and actual torque)
- The speed reference ramp or torque reference

Two-Quadrant Three-Phase Rectifier DC Drive

Model Specifications

The library contains a 5 hp and a 200 hp drive parameter set. The specifications of these two drives are shown in the following table.

5 HP and 200 HP Drive Specifications

		5 HP Drive	200 HP Drive
Drive Input Voltage	Amplitude	220 V	460 V
	Frequency	50 Hz	60 Hz
	Motor Nominal Values		
	Power	5 hp	200 hp
	Speed	1750 rpm	1750 rpm
	Voltage	240 V	500 V

Example

The dc3_examp1e demo illustrates the three-phase rectifier drive used with the 200 hp drive parameter set during torque regulation. A 5 hp parameter set is also available in the library.

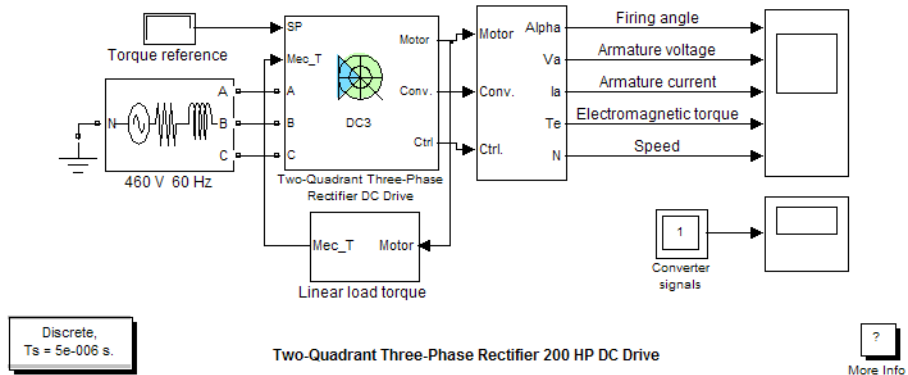

The rectifier is fed by a 460 V AC 60 Hz voltage source.

Two-Quadrant Three-Phase Rectifier DC Drive

The motor is coupled to a linear load, which means that the mechanical torque of the load is proportional to the speed.

The initial torque reference is set to 0 N.m and the armature current is null. No electromagnetic torque is produced, and the motor stays still.

At $t = 0.05$ s, the torque reference jumps to 800 N.m. This causes the armature current to rise to about 305 A. Notice that the armature current follows the reference quite accurately, with fast response time and small overshooting. The 15 mH smoothing inductance keeps the current oscillations quite small. Observe also that the average firing angle value stays below 90 degrees, the converter being in rectifier mode.

The electromagnetic torque produced by the armature current flow causes the motor to accelerate. The speed rises and starts to stabilize around $t = 5$ s at about 1450 rpm, the sum of the load and viscous friction torques beginning to equalize the electromagnetic torque.

At $t = 5$ s, the torque reference is set to 400 N.m and the armature current jumps down to about 155 A. This causes the load torque to decelerate the motor.

At $t = 10$ s speed starts to stabilize around 850 rpm.

The following figure illustrates the results obtained respectively with the detailed and average-value converters. Average voltage, current, torque and speed values are identical for both models. The average firing angle values however are slightly different. Notice that the higher frequency signal components are not represented with the simplified converter.

Two-Quadrant Three-Phase Rectifier DC Drive

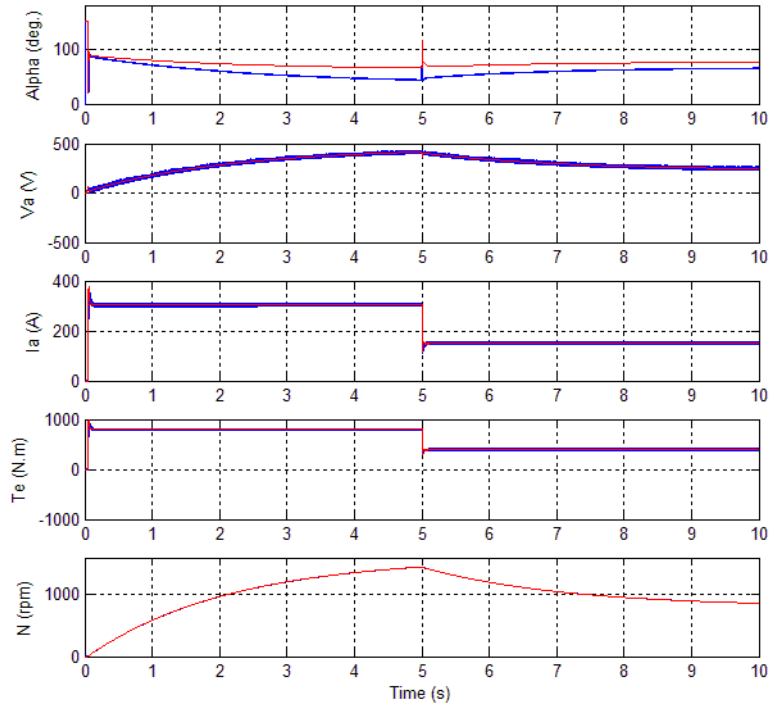

DC3 Example Waveforms (Blue : Detailed Converter, Red : Average-Value Converter)

References

- [1] Sen, P.C., *Thyristor DC Drives*, J.Wiley and Sons, 1981.
- [2] Nondahl, Thomas A., *Microprocessor Control of Motor Drives and Power Converters*, tutorial course, IEEE Industry Application Society, October 1993, pp. 7.1-7.26.

Purpose

Implement a universal power converter with selectable topologies and power electronic devices

Library

Power Electronics

Description

The Universal Bridge block implements a universal three-phase power converter that consists of up to six power switches connected in a bridge configuration. The type of power switch and converter configuration are selectable from the dialog box.

The Universal Bridge block allows simulation of converters using both naturally commutated (or line-commutated) power electronic devices (diodes or thyristors) and forced-commutated devices (GTO, IGBT, MOSFET).

The Universal Bridge block is the basic block for building two-level voltage-sourced converters (VSC).

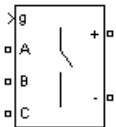
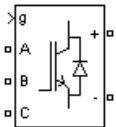
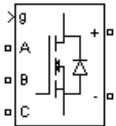
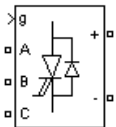
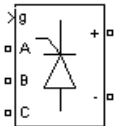
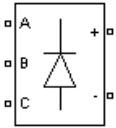

Diode bridge:

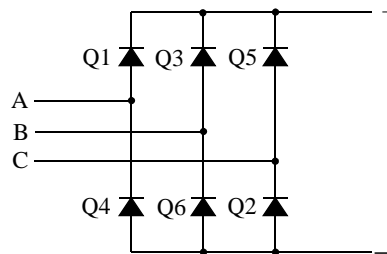

Thyristor bridge:

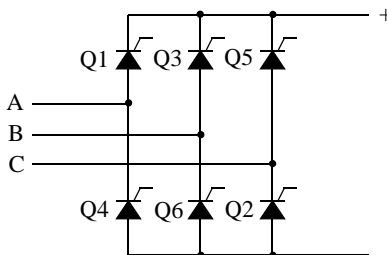

Universal Bridge

GTO-Diode bridge:

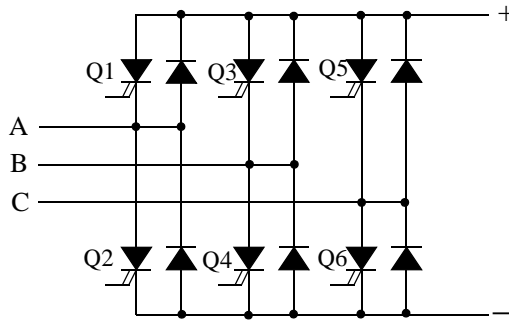

IGBT-Diode bridge:

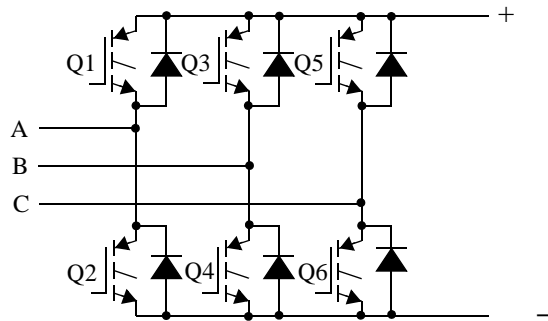

MOSFET-Diode and Ideal Switch bridges:

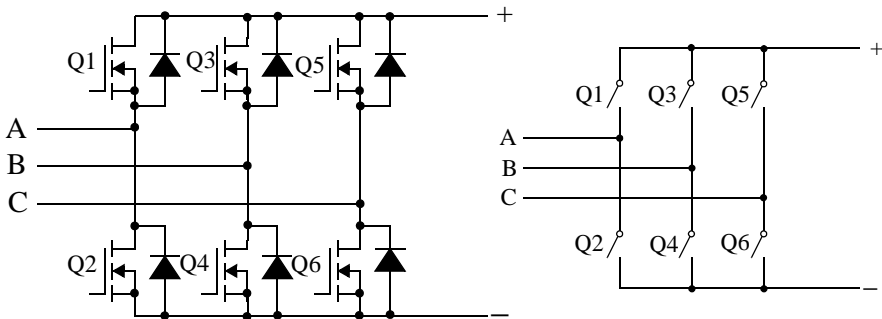

Note The device numbering is different if the power electronic devices are naturally commutated or forced-commutated. For a naturally commutated converter, numbering follows the natural order of commutation.

Dialog Box and Parameters

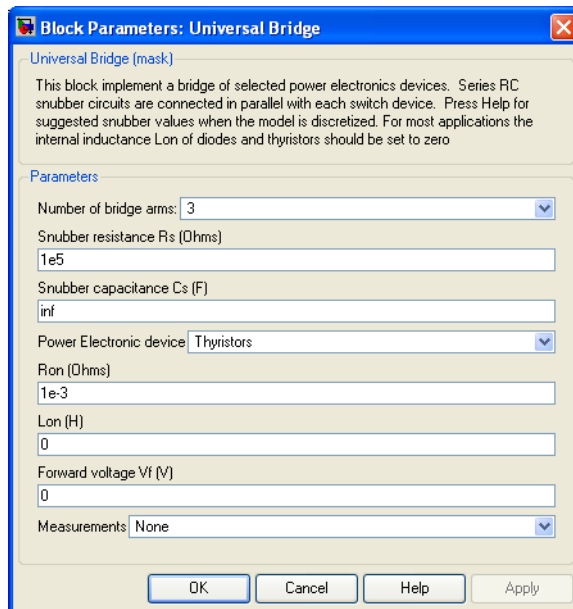

Number of bridge arms

Set to 1 or 2 to get a single-phase converter (two or four switching devices).
Set to 3 to get a three-phase converter connected in Graetz bridge configuration (six switching devices).

Snubber resistance R_s

The snubber resistance, in ohms (Ω). Set the **Snubber resistance R_s** parameter to `inf` to eliminate the snubbers from the model.

Universal Bridge

Snubber capacitance C_s

The snubber capacitance, in farads (F). Set the **Snubber capacitance C_s** parameter to 0 to eliminate the snubbers, or to `inf` to get a resistive snubber.

In order to avoid numerical oscillations when your system is discretized, you need to specify R_s and C_s snubber values for diode and thyristor bridges. For forced-commutated devices (GTO, IGBT, or MOSFET), the bridge operates satisfactorily with purely resistive snubbers as long as firing pulses are sent to switching devices.

If firing pulses to forced-commutated devices are blocked, only antiparallel diodes operate, and the bridge operates as a diode rectifier. In this condition appropriate values of R_s and C_s must also be used.

When the system is discretized, use the following formulas to compute approximate values of R_s and C_s :

$$R_s > 2 \frac{T_s}{C_s}$$

$$C_s < \frac{P_n}{1000(2\pi f)V_n^2}$$

where

P_n = Nominal power of single or three phase converter (VA)

V_n = Nominal line-to-line AC voltage (V_{rms})

f = Fundamental frequency (Hz)

T_s = Sample Time (s)

These R_s and C_s values are derived from the following two criteria:

- The snubber leakage current at fundamental frequency is less than 0.1% of nominal current when power electronic devices are not conducting.
- The RC time constant of snubbers is higher than two times the sample time T_s .

These R_s and C_s values that guarantee numerical stability of the discretized bridge can be different from actual values used in a physical circuit.

Power electronic device

Select the type of power electronic device to use in the bridge.

Ron

Internal resistance of the selected device, in ohms (Ω).

Lon

Internal inductance, in henries (H), for the diode or the thyristor device. When the bridge is discretized, the Lon parameter must be set to zero.

Forward voltage Vf

This parameter is available only when the selected **Power electronic device** is Diodes or Thyristors.

Forward voltage, in volts (V), across the device when it is conducting.

Forward voltages [Device Vf, Diode Vfd]

This parameter is available when the selected **Power electronic device** is GTO/Diodes or IGBT/Diodes.

Forward voltages, in volts (V), of the forced-commutated devices (GTO, MOSFET, or IGBT) and of the antiparallel diodes.

[Tf (s) Tt (s)]

Fall time Tf and tail time Tt, in seconds (s), for the GTO or the IGBT devices.

Measurements

Select `Device` voltages to measure the voltages across the six power electronic device terminals.

Select `Device` currents to measure the currents flowing through the six power electronic devices. If antiparallel diodes are used, the measured current is the total current in the forced-commutated device (GTO, MOSFET, or IGBT) and in the antiparallel diode. A positive current therefore indicates a current flowing in the forced-commutated device and a negative current indicates a current flowing in the diode. If snubber devices are defined, the measured currents are the ones flowing through the power electronic devices only.

Select `UAB` `UBC` `UCA` `UDC` voltages to measure the terminal voltages (AC and DC) of the Universal Bridge block.

Universal Bridge

Select All voltages and currents to measure all voltages and currents defined for the Universal Bridge block.

Place a Multimeter block in your model to display the selected measurements during the simulation. In the **Available Measurements** menu of the Multimeter block, the measurement is identified by a label followed by the block name.

Measurement	Label
Device voltages	Usw1:, Usw2:,Usw3:,Usw4:,Usw5:,Usw6:
Branch current	Isw1:, Isw2:, Isw3:, Isw4:, Isw5:, Isw6:
Terminal voltages	Uab:, Ubc:, Uca:, Udc:

Inputs and Outputs

g

The gate input for the controlled switch devices. The pulse ordering in the vector of the gate signals corresponds to the switch number indicated in the six circuits shown in the Description section. For the diode and thyristor bridges, the pulse ordering corresponds to the natural order of commutation. For all other forced-commutated switches, pulses are sent to upper and lower switches of phases A, B, and C.

Topology	Pulse Vector of Input g
one arm	[Q1 ,Q2]
two arms	[Q1 ,Q2 ,Q3 ,Q4]
three arms	[Q1 ,Q2 ,Q3 ,Q4 ,Q5 ,Q6]

Example

The power_bridges demo illustrates the use of two Universal Bridge blocks in an ac/dc/ac converter consisting of a rectifier feeding an IGBT inverter through a DC link. The inverter is pulse-width modulated (PWM) to produce a three-phase 50 Hz sinusoidal voltage to the load. In this example the inverter chopping frequency is 2000 Hz.

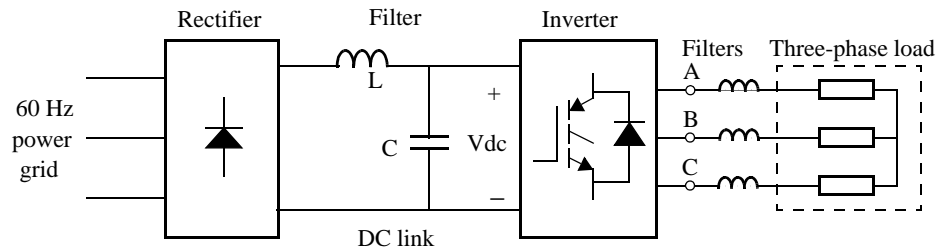

The IGBT inverter is controlled with a PI regulator in order to maintain a 1 p.u. voltage (380 Vrms, 50 Hz) at the load terminals.

Universal Bridge

A Multimeter block is used to observe commutation of currents between diodes 1 and 3 in the diode bridge and between IGBT/Diodes switches 1 and 2 in the IGBT bridge.

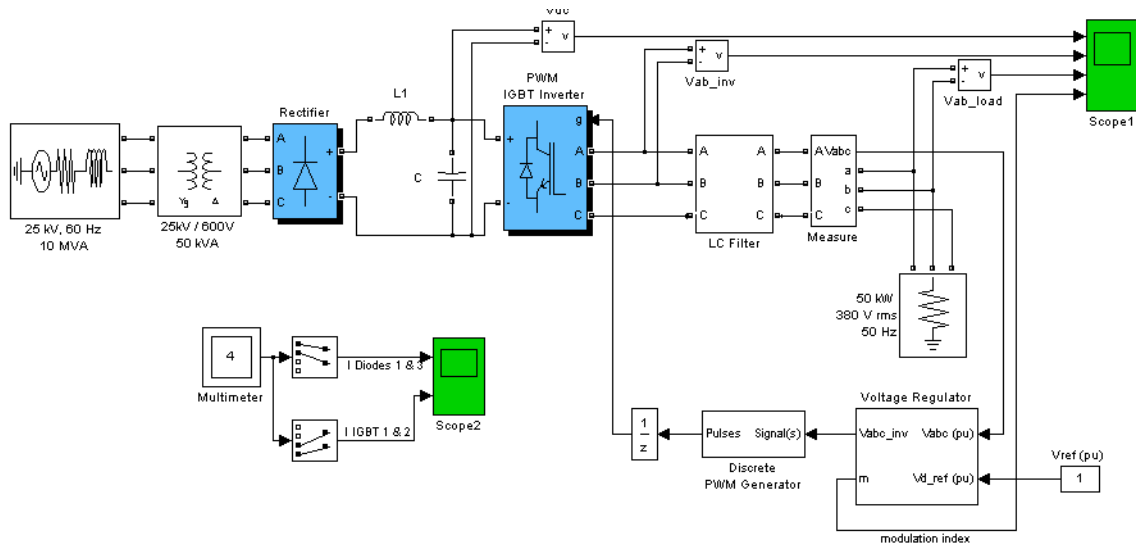

Start simulation. After a transient period of approximately 40 ms, the system reaches a steady state. Observe voltage waveforms at DC bus, inverter output, and load on Scope1. The harmonics generated by the inverter around multiples of 2 kHz are filtered by the LC filter. As expected the peak value of the load voltage is 537 V (380 V RMS).

In steady state the mean value of the modulation index is $m = 0.77$, and the mean value of the DC voltage is 780 V. The fundamental component of 50 Hz voltage buried in the chopped inverter voltage is therefore

$$V_{ab} = 780 \text{ V} * 0.612 * 0.80 = 382 \text{ V RMS}$$

Observe diode currents on trace 1 of Scope2, showing commutation from diode 1 to diode 3. Also observe on trace 2 currents in switches 1 and 2 of the IGBT/Diode bridge (upper and lower switches connected to phase A). These two currents are complementary. A positive current indicates a current flowing in the IGBT, whereas a negative current indicates a current flowing in the antiparallel diode.

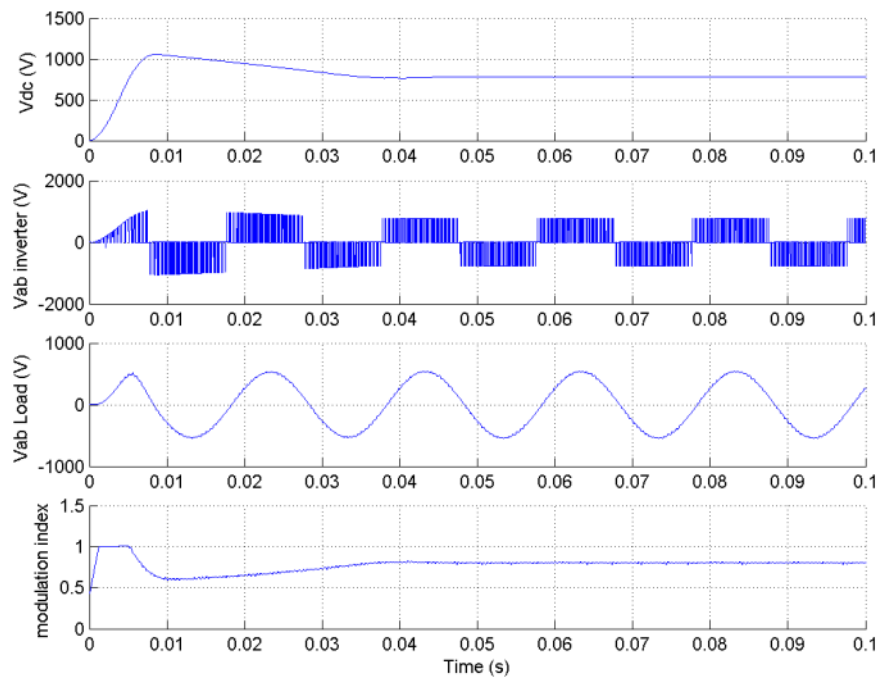

Universal Bridge

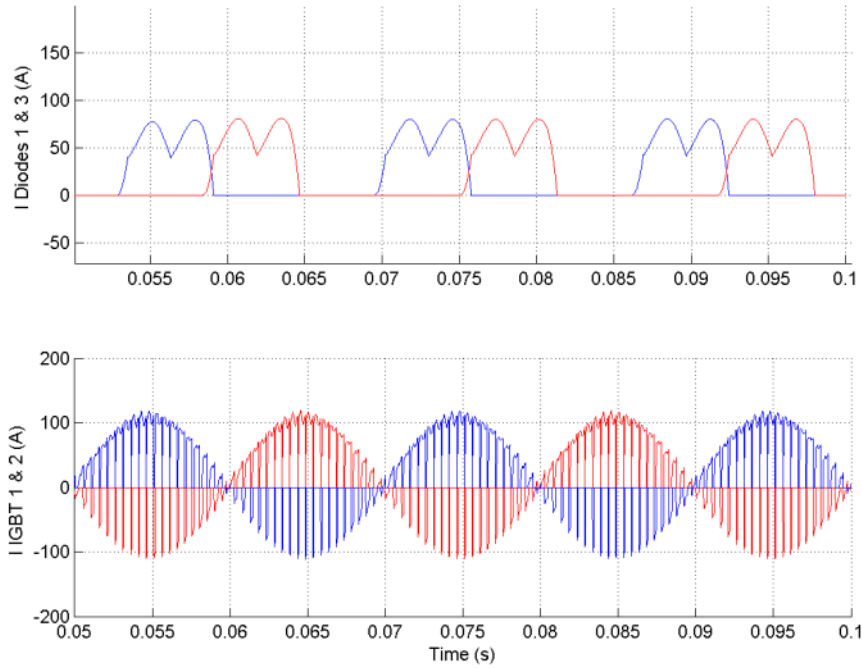

See Also

Diode, GTO, Ideal Switch, IGBT, MOSFET, Multimeter, Three-Level Bridge, Thyristor

Unified Power Flow Controller (Phasor Type)

Purpose

Implements a phasor model of a three-phase unified power flow controller

Library

Flexible AC Transmission Systems (FACTS)/Power-Electronics Based FACTS

Description

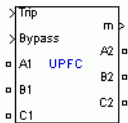

The Unified Power Flow Controller (UPFC) is the most versatile member of the Flexible AC Transmission Systems (FACTS) family using power electronics to control power flow on power grids [1]. The UPFC uses a combination of a shunt controller (STATCOM) and a series controller (SSSC) interconnected through a common DC bus as shown on the figure below.

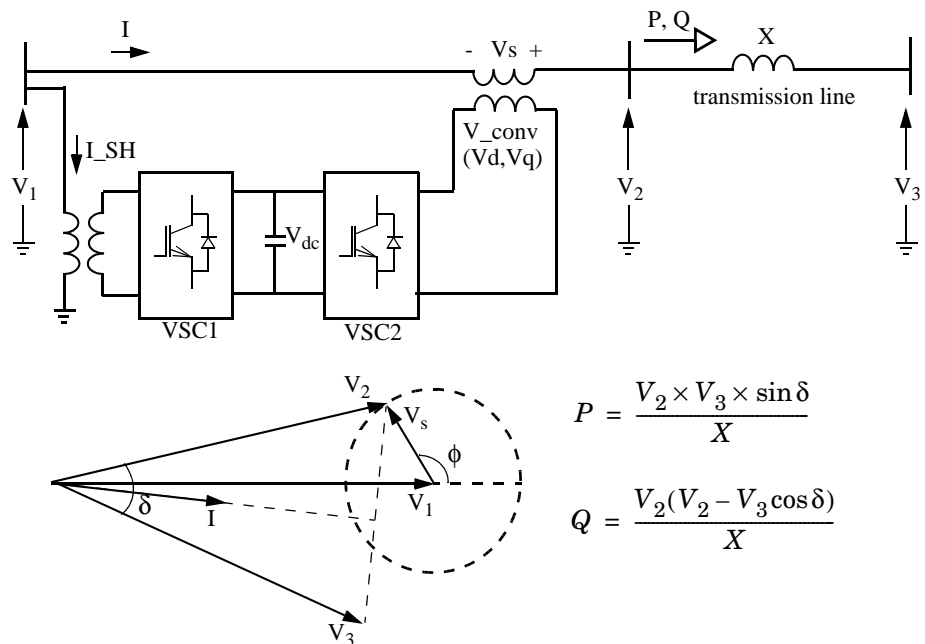

Single-line Diagram of a UPFC and Phasor Diagram of Voltages and Currents

This FACTS topology provides much more flexibility than the SSSC for controlling the line active and reactive power because active power can now be transferred from the shunt converter to the series converter, through the DC bus. Contrary to the SSSC where the injected voltage V_s is constrained to stay in quadrature with line current I , the injected voltage V_s can now have any angle with respect to line current. If the magnitude of injected voltage V_s is

Unified Power Flow Controller (Phasor Type)

kept constant and if its phase angle ϕ with respect to V_1 is varied from 0 to 360 degrees, the locus described by the end of vector V_2 ($V_2=V_1+V_s$) is a circle as shown on the phasor diagram. As ϕ is varying, the phase shift δ between voltages V_2 and V_3 at the two line ends also varies. It follows that both the active power P and the reactive power Q transmitted at one line end can be controlled. The UPFC controllable region in the P - Q plane is the area enclosed by an ellipse as shown on the figure below.

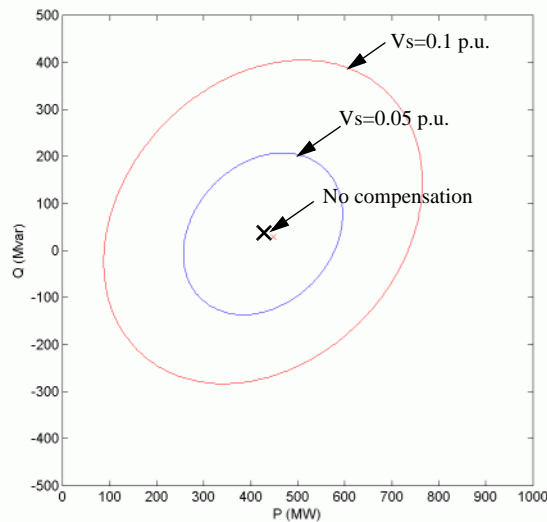

Controllable Region for a 100 MVA UPFC connected on 500 kV, 200 km line

This figure was obtained with a 100 MVA UPFC controlling active and reactive power at one end of a 500 kV, 200 km transmission line. The following parameters have been used:

- Line: length = 200km; reactance = 0.35 Ω /km
- System voltage: 500 kV
infinite sources V_1 and V_3 ; $V_1=1.0$ p.u., 0 degree; $V_3= 1.0$ p.u.,-7.22 degrees
- Series and shunt converter rating: 100 MVA
- Series converter: nominal injected voltage = 10% of nominal line-to-ground voltage (28.9 kV); impedance (transformer leakage reactance and filters) = 0.15 p.u.

Unified Power Flow Controller (Phasor Type)

With V_3 lagging V_1 by 7.22 degrees, the natural power flow without compensation is 450 MW or 50% of the line surge impedance loading (SIL=900 MW). With an injected voltage $V_s = 0.1$ p.u. any operating point inside the larger ellipse can be obtained and active power can be varied by approximately +/- 300 MW.

In addition to allow control of the line active and reactive power, the UPFC provides an additional degree of freedom. Its shunt converter operating as a STATCOM controls voltage V_1 by absorbing or generating reactive power.

Both the series and shunt converters use a Voltage-Sourced Converter (VSC) connected on the secondary side of a coupling transformer. The VSCs use forced-commutated power electronic devices (GTOs, IGBTs or IGCTs) to synthesize a voltage from a DC voltage source. The common capacitor connected on the DC side of the VSCs acts as a DC voltage source. Two VSC technologies can be used for the VSCs:

- VSC using GTO-based square-wave inverters and special interconnection transformers. Typically four three-level inverters are used to build a 48-step voltage waveform. Special interconnection transformers are used to neutralize harmonics contained in the square waves generated by individual inverters. In this type of VSC, the fundamental component of voltage is proportional to the voltage V_{dc} . Therefore V_{dc} has to varied for controlling the injected voltage.
- VSC using IGBT-based PWM inverters. This type of inverter uses Pulse-Width Modulation (PWM) technique to synthesize a sinusoidal waveform from a DC voltage with a typical chopping frequency of a few kilohertz. Harmonics are cancelled by connecting filters at the AC side of the VSC. This type of VSC uses a fixed DC voltage V_{dc} . Voltage is varied by changing the modulation index of the PWM modulator.

The UPFC (Phasor Type) block models an IGBT-based UPFC. However, as details of the inverter and harmonics are not represented, it can be also used to model a GTO-based UPFC in transient stability studies.

Control system

The shunt converter operates as a STATCOM. For a description of its control system, refer to the Static Synchronous Compensator (Phasor Type). In summary, the shunt converter controls the AC voltage at its terminals and the

Unified Power Flow Controller (Phasor Type)

voltage of the DC bus. It uses a dual voltage regulation loop: an inner current control loop and an outer loop regulating AC and DC voltages.

Control of the series branch is different from the SSSC. In a SSSC the two degrees of freedom of the series converter are used to control the DC voltage and the reactive power. In case of a UPFC the two degrees of freedom are used to control the active power and the reactive power. A simplified block diagram of the series converter is shown below.

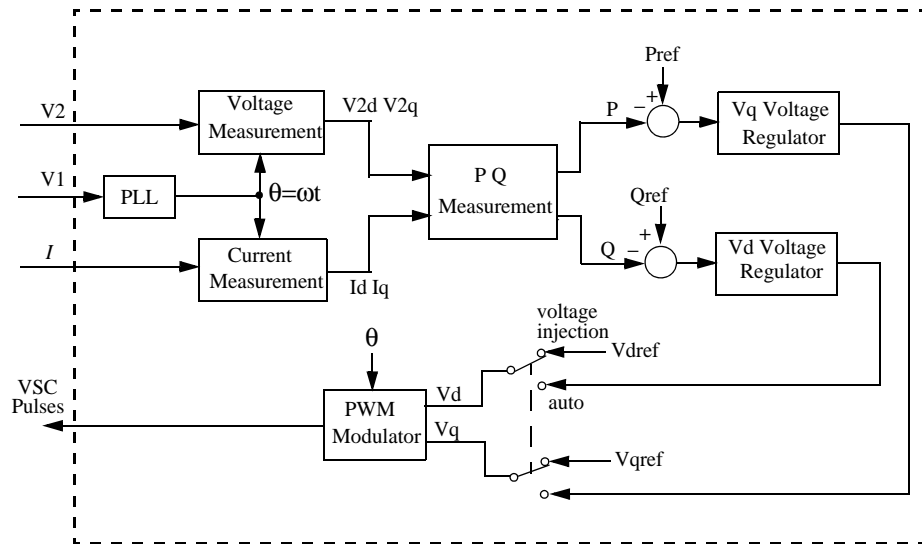

Simplified Block Diagram of the Series Converter Control System

The series converter can operate either in power flow control (automatic mode) or in manual voltage injection mode. In power control mode, the measured active power and reactive power are compared with reference values to produce P and Q errors. The P error and the Q error are used by two PI regulators to compute respectively the V_q and V_d components of voltage to be synthesized by the VSC. (V_q in quadrature with V_1 controls active power and V_d in phase with V_1 controls reactive power). In manual voltage injection mode, regulators are not used. The reference values of injected voltage V_{dref} and V_{qref} are used to synthesize the converter voltage.

Unified Power Flow Controller (Phasor Type)

The UPFC block is a phasor model which does not include detailed representation of the power electronics. You must use it with the phasor simulation method, activated with the Powergui block. It can be used in three-phase power systems together with synchronous generators, motors, dynamic loads and other FACTS and DR systems to perform transient stability studies and observe impact of the UPFC on electromechanical oscillations and transmission capacity at fundamental frequency.

Dialog Box and Parameters

The UPFC parameters are grouped in three categories: Power data, Control parameters (shunt converter), and Control parameters (series converter). Use the **Display** listbox to select which group of parameters you want to visualize.

Power Data Parameters

Block Parameters: Unified Power Flow Controller (Phasor...)

Unified Power Flow Controller (Phasor Type) (mask)
This block implements a phasor model of an Unified Power Flow Controller (UPFC).
The output (m) is a bus signal. Use the Bus Selector block to extract individual signals.

Parameters

Display: Power data

System nominal voltage and frequency [Vrms L-L, f(Hz)]:
[500e3, 60]

Shunt converter rating (VA):
[100e6]

Shunt converter impedance [R(pu) L(pu)]:
[0.22/30, 0.22]

Shunt converter initial current [Mag(pu) Pha(deg.)]:
[0, 0]

Series converter rating [Snom(VA) Max. Injected voltage(pu)]:
[100e6, 0.1]

Series converter impedance [R(pu) L(pu)]:
[0.16/30, 0.16]

Series converter initial current [Mag(pu) Pha(deg.)]:
[0, 0]

DC link nominal voltage (V)
[40000]

DC link total equivalent capacitance (F):
[750e-6]

OK Cancel Help Apply

Unified Power Flow Controller (Phasor Type)

System nominal voltage and frequency [Vrms f]

The nominal line-to-line voltage in Vrms and the nominal system frequency in hertz.

Shunt converter ratings

The nominal rating of the shunt converter in VA.

Shunt converter impedance [R L]

The positive-sequence resistance R and inductance L of the shunt converter, in p.u. based on the nominal converter rating and nominal voltage. R and L represent the resistance and leakage inductance of the shunt transformer plus the resistance and inductance of the series filtering inductors connected at the VSC output.

Shunt converter initial current [Mag Phase]

The initial value of the positive-sequence current phasor (Magnitude in p.u. and Phase in degrees). If you know the initial value of the shunt current corresponding to the UPFC operating point you may specify it in order to start simulation in steady state. If you don't know this value, you can leave [0 0]. The system will reach steady-state after a short transient.

Series converter ratings [Snom, Max. Injected voltage]

The ratings of the series converter in VA and the maximum value of the injected voltage V_conv on the VSC side of the transformer (see single line diagram), in p.u. of nominal phase-to-ground voltage.

Series converter impedance [R L]

The positive-sequence resistance and inductance of the converter, in p.u. based on the converter rated power and voltage. R and L represent the resistance and leakage inductance of the series transformer plus the resistance and inductance of the series filtering inductors connected at the VSC output.

Series converter initial current [Mag Phase]

The initial value of the positive-sequence current phasor (Magnitude in p.u. and Phase in degrees). If you know the initial value of the series current corresponding to the UPFC operating point you may specify it in order to start simulation in steady state. If you don't know this value, you can leave [0 0]. The system will reach steady-state after a short transient.

Unified Power Flow Controller (Phasor Type)

DC link nominal voltage

The nominal voltage of the DC link in volts.

DC link total equivalent capacitance

The total capacitance of the DC link in farads. This capacitance value is related to the UPFC converter ratings and to the DC link nominal voltage. The energy stored in the capacitance (in joules) divided by the converter rated power (in VA) is a time duration which is usually a fraction of a cycle at nominal frequency. For example, for the default parameters, ($C=750 \mu\text{F}$, $V_{dc}=40\,000 \text{ V}$, $S_{nom}=100 \text{ MVA}$) this ratio $(1/2 \times C \times V_{dc}^2)/(S_{nom})$ is 6.0 ms, which represents 0.36 cycle for a 60 Hz frequency. If you change the default values of the nominal power rating and DC voltage, you should change the capacitance value accordingly.

Control Parameters (shunt converter)

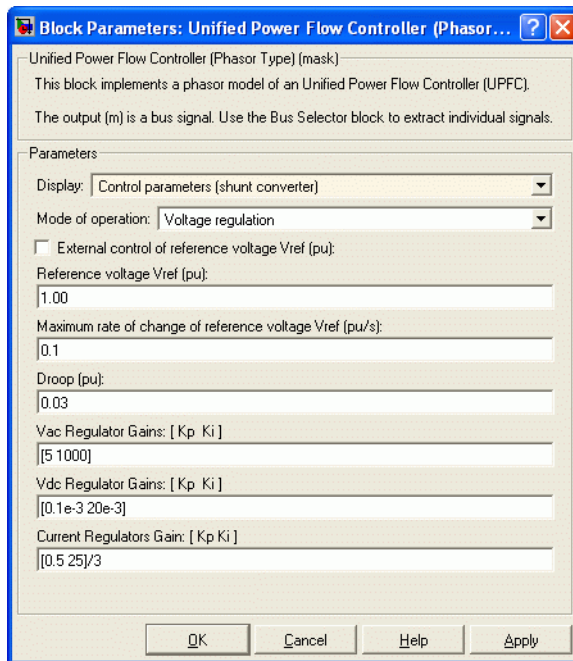

Mode of operation

Specifies the shunt converter mode of operation. Select either Voltage regulation or Var Control.

Unified Power Flow Controller (Phasor Type)

External control of reference voltage Vref

If this parameter is checked, a Simulink input named Vref appears on the block, allowing to control the reference voltage from an external signal (in p.u.). Otherwise a fixed reference voltage is used, as specified by the parameter below.

Reference voltage Vref

This parameter is not visible when the **Mode of operation** parameter is set to Var Control or when the **External control of reference voltage Vref** parameter is checked.

Reference voltage, in p.u., used by the voltage regulator.

Maximum rate of change of reference voltage Vref

This parameter is not visible when the **Mode of operation** parameter is set to Var Control.

Maximum rate of change of the reference voltage, in p.u./s, when an external reference voltage is used.

Droop

This parameter is not visible when the **Mode of operation** parameter is set to Var Control.

Droop reactance, in p.u./shunt converter rating S_{nom} , defining the slope of the V-I characteristic.

Vac Regulator Gains: [Kp Ki]

This parameter is not visible when the **Mode of operation** parameter is set to Var Control.

Gains of the AC voltage PI regulator. Specify proportional gain Kp in (p.u. of I)/(p.u. of V), and integral gain Ki, in (p.u. of I)/(p.u. of V)/s, where V is the AC voltage error and I is the output of the voltage regulator.

Reactive power setpoint Qref

This parameter is not visible when the **Mode of operation** parameter is set to Voltage Control.

Reference reactive power, in p.u., when the shunt converter is in Var Control.

Unified Power Flow Controller (Phasor Type)

Maximum rate of change of reactive power setpoint Q_{ref}

This parameter is not visible when the **Mode of operation** parameter is set to Voltage Control.

Maximum rate of change of the reference reactive power, in p.u./s.

Vdc Regulator Gains: [Kp Ki]

Gains of the DC voltage PI regulator which controls the voltage across the DC bus capacitor. Specify proportional gain K_p in (p.u. of I)/Vdc, and integral gain K_i , in (p.u. of I)/Vdc/s, where Vdc is the DC voltage error and I is the output of the voltage regulator.

Current Regulators Gains: [Kp Ki]

Gains of the inner current regulation loop.

Specify proportional gain K_p in (p.u. of V)/(p.u. of I), integral gain K_i , in (p.u. of V)/(p.u. of I)/s, where V is the output of the d or q current regulator and I is the Id or Iq current error.

The current regulator is assisted by a feed forward regulator. The feed forward gain in (p.u. of V)/(p.u. of I) is the shunt converter reactance (in p.u.) given by parameter L in the **Shunt converter impedance [R L]** parameters.

Control Parameters (series converter)

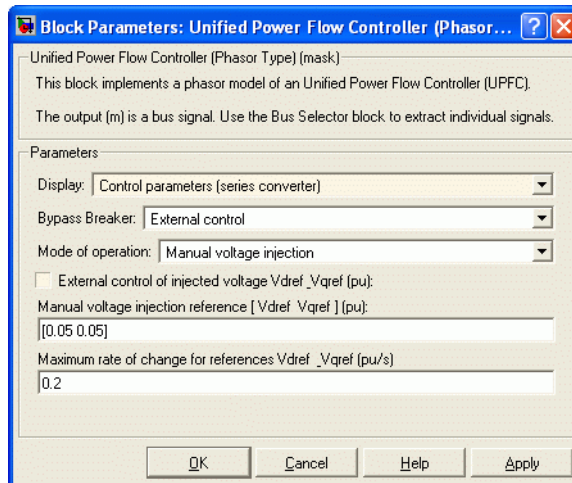

Unified Power Flow Controller (Phasor Type)

Bypass Breaker

Specifies the status of the bypass breaker connected inside the block across terminals A1, B1, C1 and A2, B2, C2. Select either External Control, Open or Closed. If the bypass breaker is in external control, a Simulink input named Bypass appears on the block, allowing to control the status of the bypass breaker from an external signal (0 or 1).

Mode of operation

Specifies the series converter mode of operation. Select either Power flow control or Manual voltage injection.

External control of power references

This parameter is not visible when the **Mode of operation** parameter is set to Manual voltage injection.

If this parameter is checked, a Simulink input named PQref appears on the block, allowing to control the active and reactive powers from an external signal (in p.u.). Otherwise, fixed reference power are used, as specified by the parameter below.

Reference active and reactive powers [Pref Qref]

This parameter is not visible when the **Mode of operation** parameter is set to Manual voltage injection.

Specify references values, in p.u.

Maximum rate of change for references Pref_Qref

This parameter is not visible when the **Mode of operation** parameter is set to Manual voltage injection.

Specify maximum rate of change of Pref and Qref, in p.u./s.

Power regulator gains: [Kp Ki]

This parameter is not visible when the **Mode of operation** parameter is set to Manual voltage injection.

Gains of the PI regulators which control the line active power and reactive power. Specify proportional gain Kp in (p.u. of Vdq)/(p.u. of PQ), and integral gain Ki, in (p.u. of Vdq)/(p.u. of PQ)/s, where Vdq is the Vd or Vq injected voltage and PQ is the P or Q voltage error.

Unified Power Flow Controller (Phasor Type)

External control of injected voltage [Vdref Vqref]

This parameter is not visible when the **Mode of operation** parameter is set to Power flow control.

If this parameter is checked, a Simulink input named Vdqref appears on the block, allowing to control the injected voltage from an external signal (in p.u.). Otherwise a fixed reference voltage is used, as specified by the parameter below.

Manual voltage injection reference [Vdref Vqref]

This parameter is not visible when the **External control of injected voltage [Vdref Vqref]** parameter is checked or when the **Mode of operation** parameter is set to Power flow control.

Specify the direct-axis and quadrature-axis components of the voltage injected on the VSC side of the series transformer, in p.u.

Maximum rate of change for references Vdref _Vqref

This parameter is not visible when the **Mode of operation** parameter is set to Power flow control.

Specify maximum rate of change of the Vdref and Vqref voltages, in p.u./s.

Inputs and Outputs

A1 B1 C1

The three input terminals of the UPFC.

A2 B2 C2

The three output terminals of the UPFC.

Trip

Apply a simulink logical signal (0 or 1) to this input. When this input is high the shunt converter is disconnected and the series converter is bypassed. In addition, when the trip signal is high the shunt and series control systems are disabled. Use this input to implement a simplified version of the protection system.

Bypass

This input is visible only when the **Bypass Breaker** parameter is set to External Control.

Apply a simulink logical signal (0 or 1) to this input. When this input is high the bypass breaker is closed.

Unified Power Flow Controller (Phasor Type)

Vdqref

This input is visible only when the **External control of injected voltage Vdref_Vqref** parameter is checked.

Apply a simulink vectorized signal specifying the reference voltages Vdref and Vqref, in p.u.

PQref

This input is visible only when the **External control of power references Pref_Qref** parameter is checked.

Apply a simulink vectorized signal specifying the reference powers Pref and Qref, in p.u.

m

Simulink output vector containing 34 UPFC internal signals. These signals are either voltage and current phasors (complex signals) or control signals. They can be individually accessed by using the Bus Selector block. They are, in order:

Signal	Signal Group	Signal Names	Definition
1-3	Power Vabc1 (cmplx)	Va1 (pu) Vb1 (pu) Vc1 (pu)	Phasor voltages (phase to ground) Va, Vb, Vc at the UPFC input terminals A1, B1, C1 (p.u.)
4-6	Power Iabc_SH (cmplx)	Ia_SH (pu) Ib_SH (pu) Ic_SH (pu)	Phasor currents Ia, Ib, Ic flowing into the shunt converter (p.u.)
7	Power	Vdc (V)	DC voltage (V)
8-10	Power Vabc2 (cmplx)	Va2 (pu) Vb2 (pu) Vc2 (pu)	Phasor voltages (phase to ground) Va, Vb, Vc at the UPFC output terminals A2, B2, C2 (p.u.)
11-13	Power Vabc_Inj (cmplx)	Va_Inj (pu) Vb_Inj (pu) Vc_Inj (pu)	Phasors of injected voltages $V_s = V_2 - V_1$ (p.u.)

Unified Power Flow Controller (Phasor Type)

Signal	Signal Group	Signal Names	Definition (Continued)
14_16	Power Iabc_SE (cmplx)	Ia_SE (pu) Ib_SE (pu) Ic_SE (pu)	Phasor currents Ia, Ib, Ic flowing in the series transformer from ABC1 to ABC2 (p.u.)
17	Control (Shunt)	Vm (pu)	Positive-sequence value of the measured voltage (p.u.)
18	Control (Shunt)	Vref (pu)	Reference voltage (p.u.)
19	Control (Shunt)	Qm (pu)	Shunt converter reactive power. A positive value indicates inductive operation.
20	Control (Shunt)	Qref (pu)	Reference reactive power (p.u.)
21	Control (Shunt)	Id (pu)	Direct-axis component of current (active current) flowing into the shunt converter (p.u.). A positive value indicates active power flowing into shunt converter.
22	Control (Shunt)	Iq (pu)	Quadrature-axis component of current (reactive current) flowing into the shunt converter (p.u.). A positive value indicates capacitive operation.
23	Control (Shunt)	Idref (pu)	Reference value of direct-axis component of current flowing into shunt converter (p.u.)
24	Control (Shunt)	Iqref (pu)	Reference value of quadrature-axis component of current flowing into shunt converter (p.u.)

Unified Power Flow Controller (Phasor Type)

Signal	Signal Group	Signal Names	Definition (Continued)
25	Control (Shunt)	modindex	The modulation index m of the shunt converter PWM modulator. A positive number $0 < m < 1$. $m=1$ corresponds to the maximum voltage which can be generated by the VSC without overmodulation.
26	Control (Series)	P (pu)	Measured active power flowing out of terminals A2, B2, C2 (p.u.)
27	Control (Series)	Q (pu)	Measured reactive power flowing out of terminals A2, B2, C2 (p.u.)
28	Control (Series)	Pref (pu)	Reference active power (p.u.)
29	Control (Series)	Qref (pu)	Reference reactive power (p.u.)
30	Control (Series)	Vd_conv (pu)	Direct-axis injected voltage on VSC side of series transformer (p.u.)
31	Control (Series)	Vq_conv (pu)	Quadrature-axis injected voltage on VSC side of series transformer (p.u.)
32	Control (Series)	Vdref (pu)	Reference value of direct-axis injected voltage (p.u.)
33	Control (Series)	Vqref (pu)	Reference value of quadrature-axis injected voltage (p.u.)
34	Control (Series)	modindex	The modulation index m of the series converter PWM modulator. A positive number $0 < m < 1$. $m=1$ corresponds to the maximum voltage V_{conv} which can be generated by the series converter without overmodulation.

Unified Power Flow Controller (Phasor Type)

Example

See the power_upfc demo which illustrates the use of a UPFC controlling power on a 500 kV, 60 Hz, system.

References

[1] N. G. Hingorani, L. Gyugyi, "Understanding FACTS; Concepts and Technology of Flexible AC Transmission Systems," IEEE Press book, 2000

See Also

Static Synchronous Compensator (Phasor Type), Static Synchronous Series Compensator (Phasor Type)

Voltage Measurement

Purpose Measure a voltage in a circuit

Library Measurements

Description The Voltage Measurement block measures the instantaneous voltage between two electric nodes. The output provides a Simulink signal that can be used by other Simulink blocks.



Dialog Box and Parameters

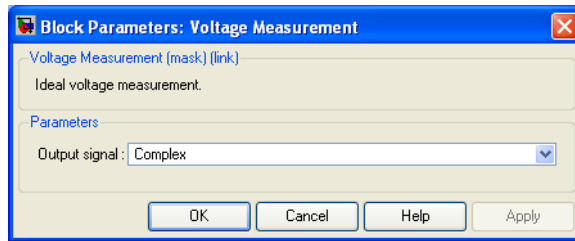

Output signal

Specifies the format of the output signal when the block is used in a phasor simulation. The **Output signal** parameter is disabled when the block is not used in a phasor simulation. The phasor simulation is activated by a Powergui block placed in the model.

Set to **Complex** to output the measured current as a complex value. The output is a complex signal.

Set to **Real - Imag** to output the real and imaginary parts of the measured current. The output is a vector of two elements.

Set to **Magnitude - Angle** to output the magnitude and angle of the measured current. The output is a vector of two elements.

Set to **Magnitude** to output the magnitude of the measured current. The output is a scalar value.

Voltage Measurement

Example

The power_voltmeasure demo uses three Voltage Measurement blocks to read voltages.

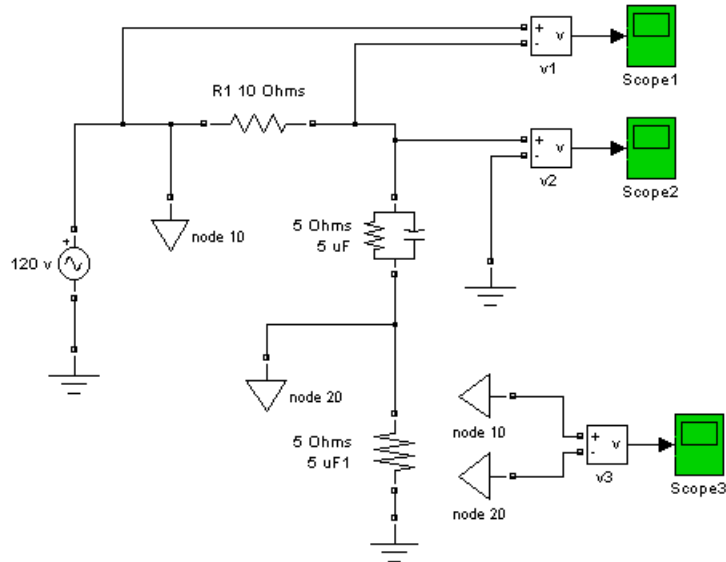

See Also

Current Measurement, Powergui, Three-Phase V-I Measurement

Wind Turbine

Purpose

Implement a model of a variable pitch wind turbine.

Library

Distributed Resources/Wind Generation

Description

The model is based on the steady-state power characteristics of the turbine. The stiffness of the drive train is infinite and the friction factor and the inertia of the turbine must be combined with those of the generator coupled to the turbine. The output power of the turbine is given by the following equation.

$$P_m = c_p(\lambda, \beta) \frac{\rho A}{2} v_{wind}^3 \quad (7-1)$$

where

P_m Mechanical output power of the turbine (W)

c_p Performance coefficient of the turbine

ρ Air density (kg/m^3)

A Turbine swept area (m^2)

v_{wind} Wind speed (m/s)

λ Tip speed ratio of the rotor blade tip speed to wind speed

β Blade pitch angle (deg)

Equation 7-1 can be normalized. In the per unit (p.u.) system we have:

$$P_{m_pu} = k_p c_{p_pu} v_{wind_pu}^3 \quad (7-2)$$

(7-3)

where

P_{m_pu} Power in p.u. of nominal power for particular values of ρ and A

c_{p_pu} Performance coefficient in p.u. of the maximum value of c_p

v_{wind_pu} Wind speed in p.u. of the base wind speed. The base wind speed is the mean value of the expected wind speed in m/s.

k_p Power gain for $c_{p_pu}=1$ pu and $v_{wind_pu}=1$ pu, k_p is less than or equal to 1

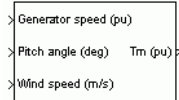
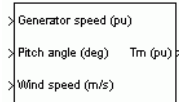

A generic equation is used to model $c_p(\lambda, \beta)$. This equation, based on the modeling turbine characteristics of [1], is:

$$c_p(\lambda, \beta) = c_1 \left(\frac{c_2}{\lambda_i} - c_3 \beta - c_4 \right) e^{\frac{-c_5}{\lambda_i}} + c_6 \lambda \quad (7-4)$$

with

$$\frac{1}{\lambda_i} = \frac{1}{\lambda + 0.08\beta} - \frac{0.035}{\beta^3 + 1} \quad (7-5)$$

The coefficients c_1 to c_6 are: $c_1 = 0.5176$, $c_2 = 116$, $c_3 = 0.4$, $c_4 = 5$, $c_5 = 21$ and $c_6 = 0.0068$. The c_p - λ characteristics, for different values of the pitch angle β , are illustrated below. The maximum value of c_p ($c_{pmax} = 0.48$) is achieved for $\beta = 0$ degree and for $\lambda = 8.1$. This particular value of λ is defined as the nominal value (λ_{nom}).

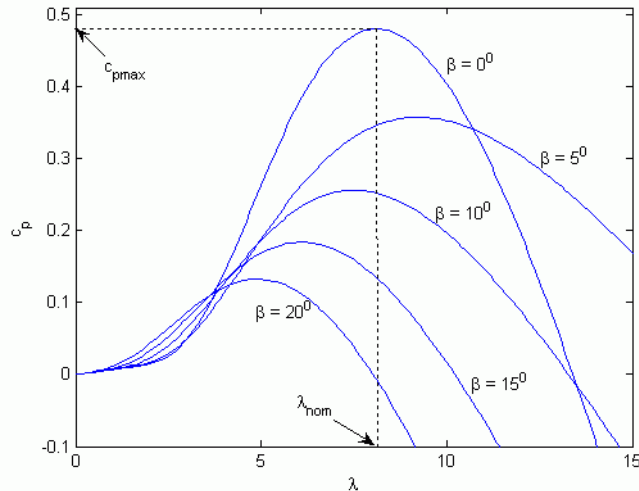

The Simulink model of the turbine is illustrated in the following figure. The three inputs are the generator speed (ω_r pu) in p.u. of the nominal speed of the generator, the pitch angle in degrees and the wind speed in m/s. The tip speed ratio λ in p.u. of λ_{nom} is obtained by the division of the rotational speed in p.u.

Wind Turbine

of the base rotational speed (defined below) and the wind speed in p.u of the base wind speed. The output is the torque applied to the generator shaft.

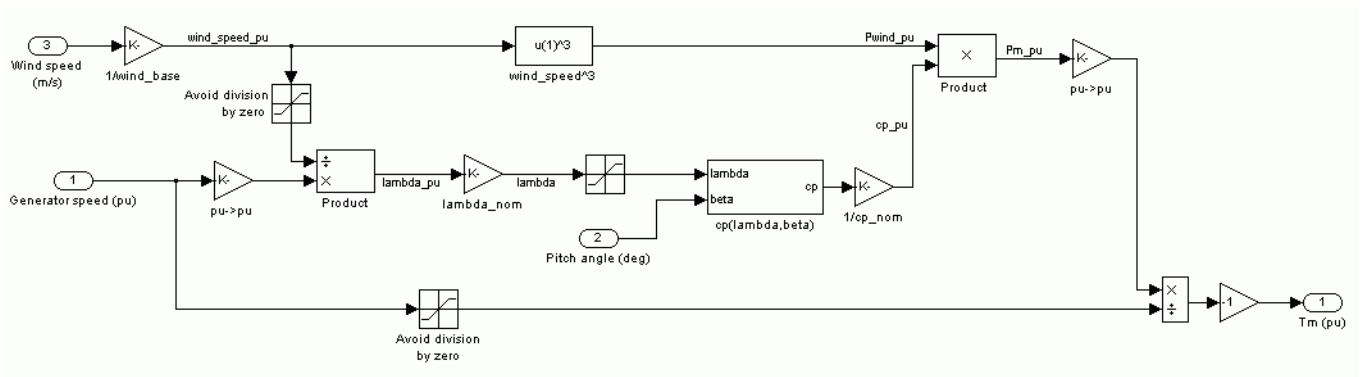

Dialog Box and Parameters

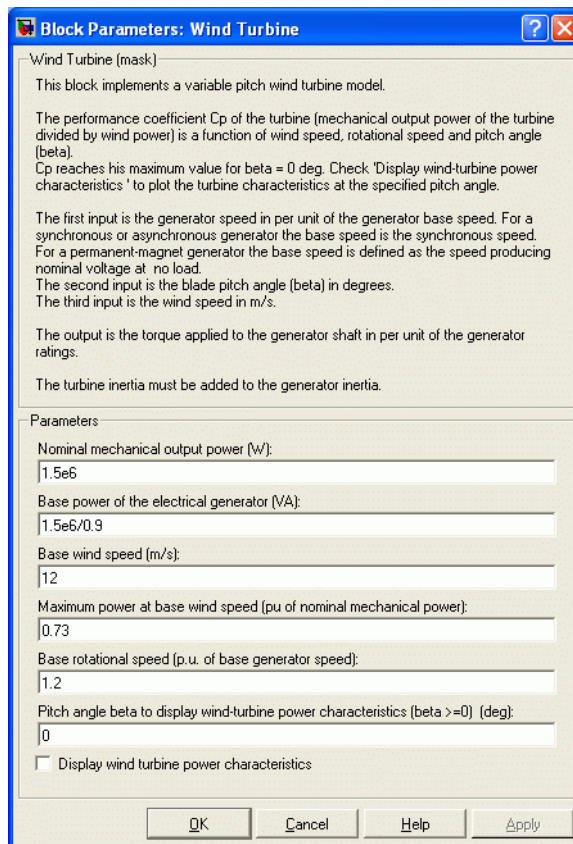

Nominal mechanical output power

The nominal output power in watts (W).

Base power of the electrical generator

The nominal power of the electrical generator coupled to the wind turbine, in VA. This parameter is used to compute the output torque in p.u. of the nominal torque of the generator.

Base wind speed

The base value of the wind speed, in m/s, used in the per unit system. The base wind speed is the mean value of the expected wind speed. This base

Wind Turbine

wind speed produces a mechanical power which is usually lower than the turbine nominal power.

Maximum power at base wind speed

The maximum power at base wind speed in p.u. of the nominal mechanical power. This parameter is the power gain k_p already defined.

Base rotational speed

The rotational speed at maximum power for the base wind speed. The base rotational speed is in p.u. of the base generator speed.

Pitch angle beta to display wind turbine power characteristics

The pitch angle beta, in degrees, used to display the power characteristics. Beta must be greater than or equal to zero.

Display wind turbine power characteristics

If this parameter is checked, the turbine power characteristics are displayed for different wind speeds and for the specified pitch angle beta.

Inputs and Outputs

Generator speed (pu)

Simulink input of the generator speed in p.u. based on the nominal speed of the generator.

Pitch angle (deg)

Simulink input of the pitch angle.

Wind speed (m/s)

Simulink input of the wind speed in m/s.

Tm (pu)

Simulink output of the mechanical torque of the wind turbine, in p.u. of the nominal generator torque. The nominal torque of the generator is based on the nominal generator power and speed.

Example

The mechanical power P_m as a function of generator speed, for different wind speeds and for blade pitch angle $\beta = 0$ degree, is illustrated below. This figure is obtained with the default parameters (base wind speed = 12 m/s, maximum power at base wind speed = 0.73 pu ($k_p = 0.73$) and base rotational speed = 1.2 pu).

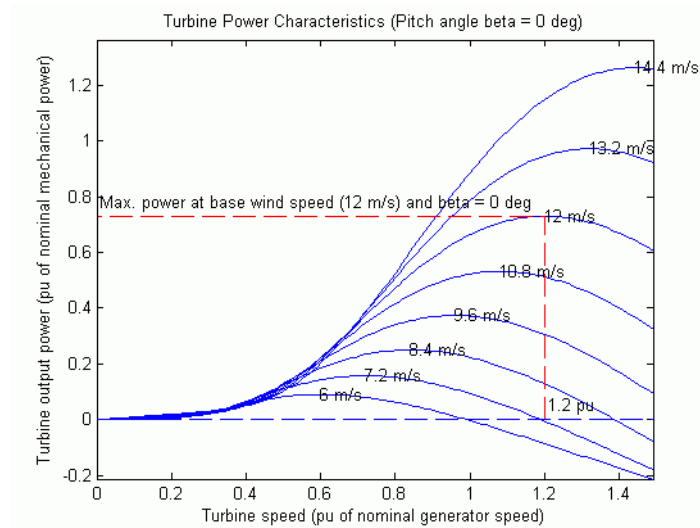

References

[1] Siegfried Heier, "Grid Integration of Wind Energy Conversion Systems," John Wiley & Sons Ltd, 1998, ISBN 0-471-97143-X

See Also

Wind Turbine Induction Generator (Phasor Type), Wind Turbine Doubly-Fed Induction Generator (Phasor Type)

Wind Turbine Doubly-Fed Induction Generator (Phasor Type)

Purpose Implement a phasor model of a variable speed doubly-fed induction generator driven by a wind turbine.

Library Distributed Resources/Wind Generation

Description

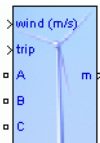

The wind turbine and the doubly-fed induction generator (WTDFIG) are shown in the figure called “The wind turbine and the doubly-fed induction generator system” on page 7-713. The AC/DC/AC converter is divided into two components: the rotor-side converter (C_{rotor}) and the grid-side converter (C_{grid}). C_{rotor} and C_{grid} are Voltage-Sourced Converters that use forced-commutated power electronic devices (IGBTs) to synthesize an AC voltage from a DC voltage source. A capacitor connected on the DC side acts as the DC voltage source. A coupling inductor L is used to connect C_{grid} to the grid. The three-phase rotor winding is connected to C_{rotor} by slip rings and brushes and the three-phase stator winding is directly connected to the grid. The power captured by the wind turbine is converted into electrical power by the induction generator and it is transmitted to the grid by the stator and the rotor windings. The control system generates the pitch angle command and the voltage command signals V_r and V_{gc} for C_{rotor} and C_{grid} respectively in order to control

Wind Turbine Doubly-Fed Induction Generator (Phasor Type)

the power of the wind turbine, the DC bus voltage and the reactive power or the voltage at the grid terminals.

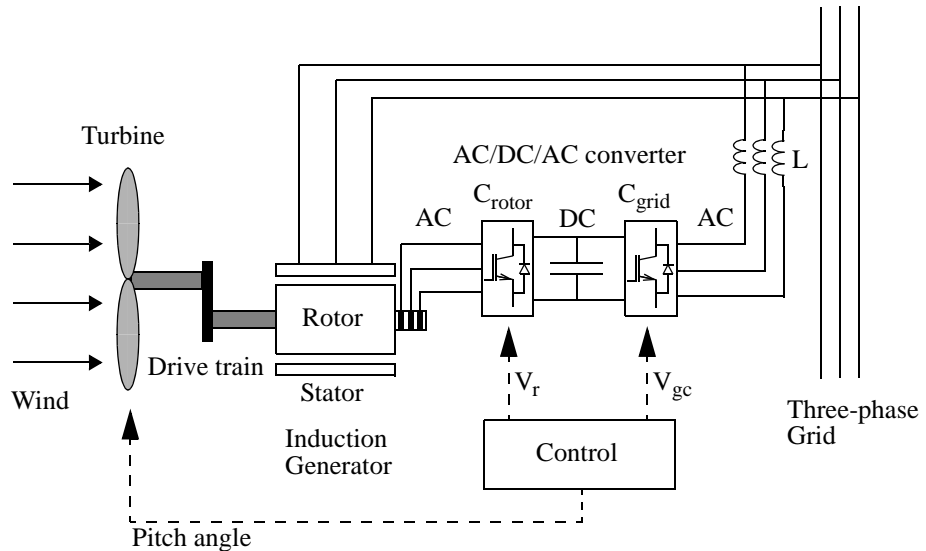

The Wind Turbine and the Doubly-Fed Induction Generator System

Operating Principle of the Wind Turbine Doubly-Fed Induction Generator

The power flow, illustrated in the figure called “The Power Flow” on page 7-715, is used to describe the operating principle. In this figure the followings parameters are used:

P_m	Mechanical power captured by the wind turbine and transmitted to the rotor
P_s	Stator electrical power output
P_r	Rotor electrical power output
P_{gc}	C_{grid} electrical power output
Q_s	Stator reactive power output
Q_r	Rotor reactive power output

Wind Turbine Doubly-Fed Induction Generator (Phasor Type)

Q_{gc}	C_{grid} reactive power output
T_m	Mechanical torque applied to rotor
T_{em}	Electromagnetic torque applied to the rotor by the generator
ω_r	Rotational speed of rotor
ω_s	Rotational speed of the magnetic flux in the air-gap of the generator, this speed is named synchronous speed. It is proportional to the frequency of the grid voltage and to the number of generator poles.
J	Combined rotor and wind turbine inertia coefficient

The mechanical power and the stator electric power output are computed as follows:

$$P_m = T_m \omega_r$$

$$P_s = T_{em} \omega_s$$

For a loss less generator the mechanical equation is:

$$J \frac{d\omega_r}{dt} = T_m - T_{em}$$

In steady-state at fixed speed for a loss less generator $T_m = T_{em}$ and

$$P_m = P_s + P_r$$

It follows that:

$$P_r = P_m - P_s = T_m \omega_r - T_{em} \omega_s = -T_m \left(\frac{\omega_s - \omega_r}{\omega_s} \right) \omega_s = -s T_m \omega_s = -s P_s$$

Wind Turbine Doubly-Fed Induction Generator (Phasor Type)

where s is defined as the slip of the generator: $s = \frac{\omega_s - \omega_r}{\omega_s}$

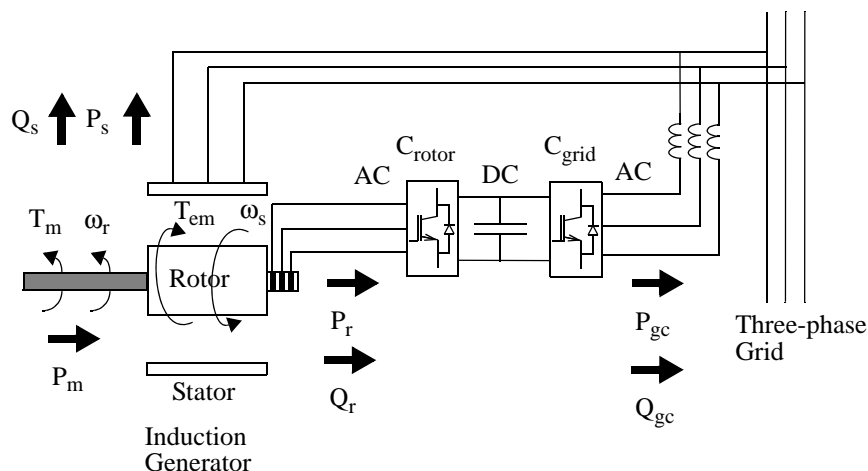

The Power Flow

Generally the absolute value of slip is much lower than 1 and, consequently, P_r is only a fraction of P_s . Since T_m is positive for power generation and since ω_s is positive and constant for a constant frequency grid voltage, the sign of P_r is a function of the slip sign. P_r is positive for negative slip (speed greater than synchronous speed) and it is negative for positive slip (speed lower than synchronous speed). For super-synchronous speed operation, P_r is transmitted to DC bus capacitor and tends to rise the DC voltage. For sub-synchronous speed operation, P_r is taken out of DC bus capacitor and tends to decrease the DC voltage. C_{grid} is used to generate or absorb the power P_{gc} in order to keep the DC voltage constant. In steady-state for a loss less AC/DC/AC converter P_{gc} is equal to P_r and the speed of the wind turbine is determined by the power P_r absorbed or generated by C_{rotor} . The power control will be explained below.

The phase-sequence of the AC voltage generated by C_{rotor} is positive for sub-synchronous speed and negative for super-synchronous speed. The frequency of this voltage is equal to the product of the grid frequency and the absolute value of the slip.

Wind Turbine Doubly-Fed Induction Generator (Phasor Type)

C_{rotor} and C_{grid} have the capability of generating or absorbing reactive power and could be used to control the reactive power or the voltage at the grid terminals.

C_rotor Control System

The rotor-side converter is used to control the wind turbine output power and the voltage (or reactive power) measured at the grid terminals.

Power Control

The power is controlled in order to follow a pre-defined power-speed characteristic, named tracking characteristic. An example of such a characteristic is illustrated in the figure called “Turbine Characteristics and Tracking Characteristic” on page 7-717, by the ABCD curve superimposed to the mechanical power characteristics of the turbine obtained at different wind speeds. The actual speed of the turbine ω_r is measured and the corresponding mechanical power of the tracking characteristic is used as the reference power for the power control loop. The tracking characteristic is defined by four points: A, B, C and D. From zero speed to speed of point A the reference power is zero. Between point A and point B the tracking characteristic is a straight line, the speed of point B must be greater than the speed of point A. Between point B and point C the tracking characteristic is the locus of the maximum power of the turbine (maxima of the turbine power vs turbine speed curves). The tracking characteristic is a straight line from point C and point D. The power at point D is one per unit (1 p.u.) and the speed of the point D must be greater than the speed of point C. Beyond point D the reference power is a constant equal to one per unit (1 p.u.).

Wind Turbine Doubly-Fed Induction Generator (Phasor Type)

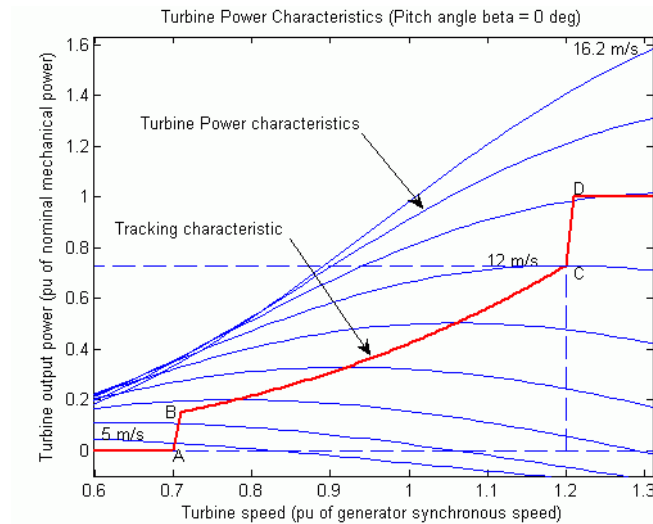

Turbine Characteristics and Tracking Characteristic

The generic power control loop is illustrated in the figure called “Rotor-Side Converter Control System” on page 7-718. The actual electrical output power, measured at the grid terminals of the wind turbine, is added to the total power losses (mechanical and electrical) and is compared with the reference power obtained from the tracking characteristic. A Proportional-Integral (PI) regulator is used to reduce the power error to zero. The output of this regulator is the reference rotor current I_{qr_ref} that must be injected in the rotor by converter C_{rotor} . This is the current component that produce the electromagnetic torque T_{em} . The actual I_{qr} component of positive-sequence current is compared to I_{qr_ref} and the error is reduced to zero by a current regulator (PI). The output of this current controller is the voltage V_{qr} generated by C_{rotor} . The current regulator is assisted by feed forward terms which predict V_{qr} .

Wind Turbine Doubly-Fed Induction Generator (Phasor Type)

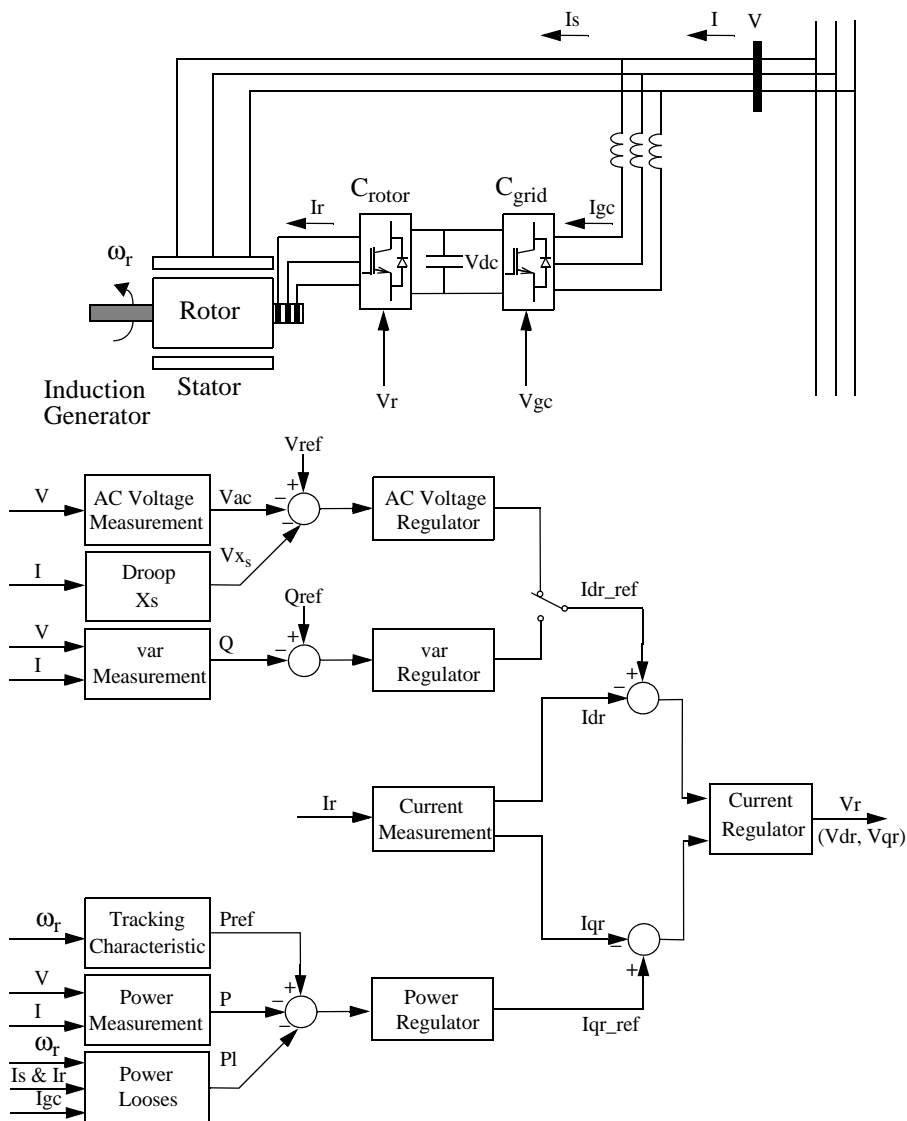

Rotor-Side Converter Control System

Wind Turbine Doubly-Fed Induction Generator (Phasor Type)

Voltage Control and Reactive Power Control

The voltage or the reactive power at grid terminals is controlled by the reactive current flowing in the converter C_{rotor} . The generic control loop is illustrated in the figure called “Rotor-Side Converter Control System” on page 7-718.

When the wind turbine is operated in voltage regulation mode, it implements the following V-I characteristic.

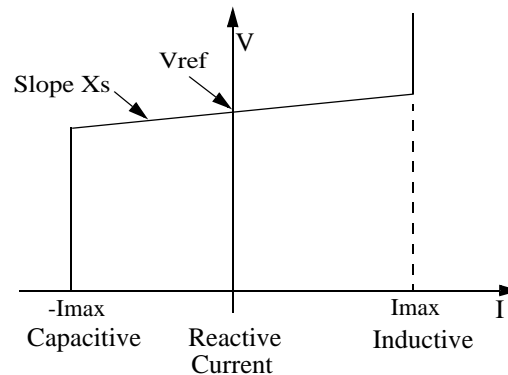

Wind Turbine V-I Characteristic

As long as the reactive current stays within the maximum current values ($-I_{max}$, I_{max}) imposed by the converter rating, the voltage is regulated at the reference voltage V_{ref} . However, a voltage droop is normally used (usually between 1% and 4% at maximum reactive power output), and the V-I characteristic has the slope indicated in the figure called “Wind Turbine V-I Characteristic” on page 7-719. In the voltage regulation mode, the V-I characteristic is described by the following equation:

$$V = V_{ref} + X_s \cdot I$$

where

Wind Turbine Doubly-Fed Induction Generator (Phasor Type)

V	Positive sequence voltage (p.u.)
I	Reactive current (p.u./Pnom) ($I > 0$ indicates an inductive current)
Xs	Slope or droop reactance (p.u./Pnom)
Pnom	Three-phase nominal power of the converter specified in the block dialog box

When the wind turbine is operated in var regulation mode the reactive power at grid terminals is kept constant by a var regulator.

The output of the voltage regulator or the var regulator is the reference d-axis current I_{dr_ref} that must be injected in the rotor by converter C_{rotor} . The same current regulator as for the power control is used to regulate the actual I_{dr} component of positive-sequence current to its reference value. The output of this regulator is the d-axis voltage V_{dr} generated by C_{rotor} . The current regulator is assisted by feed forward terms which predict V_{dr} .

V_{dr} and V_{qr} are respectively the d-axis and q-axis of the voltage V_r .

Note:

- for C_{rotor} control system and measurements the d-axis of the d-q rotating reference frame is locked on the generator mutual flux by a PLL which is assumed to be ideal in this phasor model.
- the magnitude of the reference rotor current I_r_ref is equal to $\sqrt{I_{dr_ref}^2 + I_{qr_ref}^2}$. The maximum value of this current is limited to 1 p.u. When I_{dr_ref} and I_{qr_ref} are such that the magnitude is higher than 1 p.u. the I_{qr_ref} component is reduced in order to bring back the magnitude to 1 p.u.

C_grid Control System

The converter C_{grid} is used to regulate the voltage of the DC bus capacitor. In addition, this model allows using C_{grid} converter to generate or absorb reactive power.

The control system, illustrated in the figure called “Grid-Side Converter Control System” on page 7-721, consists of:

Wind Turbine Doubly-Fed Induction Generator (Phasor Type)

- Measurement systems measuring the d and q components of AC positive-sequence currents to be controlled as well as the DC voltage V_{dc} .
- An outer regulation loop consisting of a DC voltage regulator. The output of the DC voltage regulator is the reference current I_{dgc_ref} for the current regulator (I_{dgc} = current in phase with grid voltage which controls active power flow).
- An inner current regulation loop consisting of a current regulator. The current regulator controls the magnitude and phase of the voltage generated by converter C_{grid} (V_{gc}) from the I_{dgc_ref} produced by the DC voltage regulator and specified I_{q_ref} reference. The current regulator is assisted by feed forward terms which predict the C_{grid} output voltage.

The magnitude of the reference grid converter current I_{gc_ref} is equal to

$\sqrt{I_{dgc_ref}^2 + I_{q_ref}^2}$. The maximum value of this current is limited to a value defined by the converter maximum power at nominal voltage. When I_{dgc_ref} and I_{q_ref} are such that the magnitude is higher than this maximum value the I_{q_ref} component is reduced in order to bring back the magnitude to its maximum value.

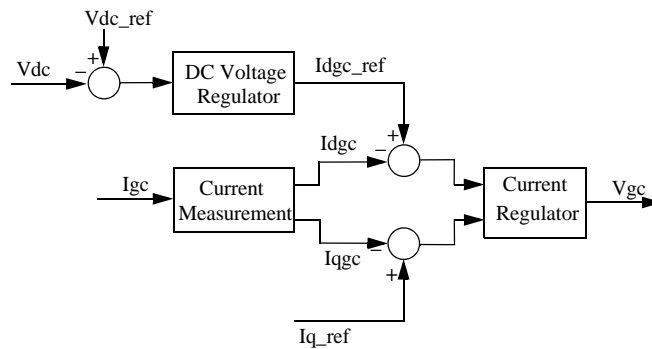

Grid-Side Converter Control System

Pitch Angle Control System

The pitch angle is kept constant at zero degree until the speed reaches point D speed of the tracking characteristic. Beyond point D the pitch angle is

Wind Turbine Doubly-Fed Induction Generator (Phasor Type)

proportional to the speed deviation from point D speed. The control system is illustrated in the following figure.

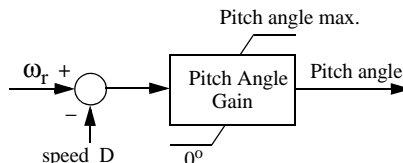

Pitch Control System

Turbine Model

The turbine model uses the Wind Turbine bloc of the Distributed Resources/Wind Generation library. See documentation of this model for more details.

Induction Generator

The doubly-fed induction generator phasor model is the same as the wound rotor asynchronous machine (see the Machines library) with the following two points of difference:

- 1 Only the positive-sequence is taken into account, the negative-sequence has been eliminated.
- 2 A trip input has been added. When this input is high the induction generator is disconnected from the grid and from C_{rotor} .

Dialog Box and Parameters

The WTDFIG parameters are grouped in four categories: Generator data, Converters data, Turbine data, and Control parameters. Use the Display listbox to select which group of parameters you want to visualize.

Wind Turbine Doubly-Fed Induction Generator (Phasor Type)

Generator Data Parameters

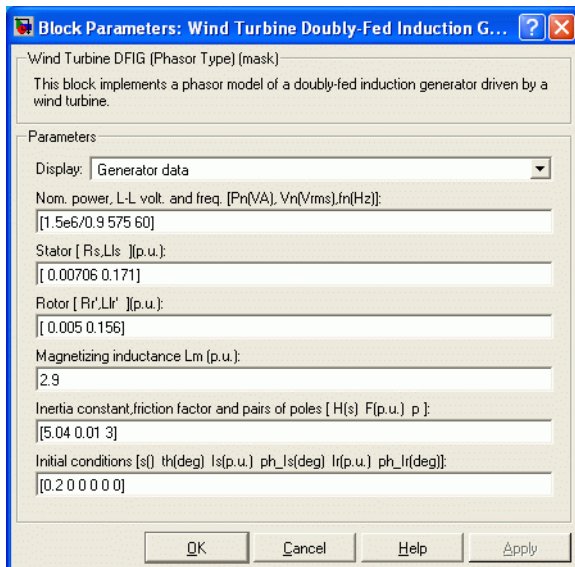

WTDFIG modeled using positive-sequence only

The WTDFIG is modeled by a three-wire system using two current sources. The WTDFIG does not generate any zero-sequence current, but it can generate negative-sequence currents during unbalanced system operation.

Nominal power, line-to-line voltage and frequency

The nominal power in VA, the nominal line-to-line voltage in Vrms and the nominal system frequency in hertz.

Stator [Rs, Lls]

The stator resistance Rs and leakage inductance Lls in p.u. based on the generator rating.

Rotor [Rr', Llr']

The rotor resistance Rr' and leakage inductance Llr', both referred to the stator, in p.u. based on the generator rating.

Magnetizing inductance Lm

The magnetizing inductance Lm in p.u. based on the generator rating.

Wind Turbine Doubly-Fed Induction Generator (Phasor Type)

Inertia constant, friction factor and pairs of poles

Combined generator and turbine inertia constant H in seconds, combined viscous friction factor F in p.u. based on the generator rating and number of pole pairs p .

You may need to use your own turbine model, in order for example, to implement different power characteristics or to implement the shaft stiffness. Your model must then output the mechanical torque applied to the generator shaft. If the inertia and the friction factor of the turbine are implemented inside the turbine model you specify only the generator inertia constant H and the generator friction factor F .

Initial conditions

The initial slip s , electrical angle θ in degrees, stator phasor current magnitude in p.u., stator phasor current phase angle in degrees, rotor phasor current magnitude in p.u. and rotor phasor current phase angle in degrees.

Converters Data Parameters

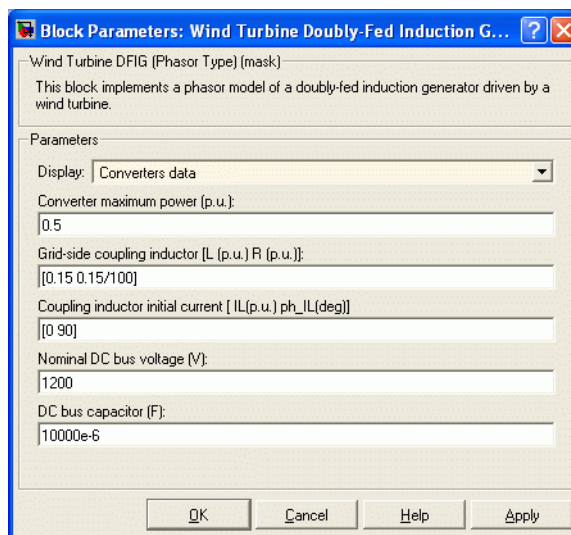

Wind Turbine Doubly-Fed Induction Generator (Phasor Type)

Converter maximum power

The maximum power of both C_{grid} and C_{rotor} in p.u. of the nominal power. This parameter is used to compute the maximum current at 1 p.u. of voltage for C_{grid} . The maximum current for C_{rotor} is 1 p.u.

Grid-side coupling inductor [L R]

The coupling inductance L and its resistance R in p.u. based on the generator rating.

Coupling inductor initial currents

The coupling inductor initial phasor current in positive-sequence. Enter magnitude IL in p.u. and phase ph_IL in degrees. If you know the initial value of the current corresponding to the WTDFIG operating point you may specify it in order to start simulation in steady state. If you don't know this value, you can leave [0 0]. The system will reach steady-state after a short transient.

Nominal DC bus voltage

The nominal DC bus voltage in volts.

DC bus capacitor

The total capacitance of the DC link in farads. This capacitance value is related to the WTDFIG rating and to the DC link nominal voltage. The energy stored in the capacitance (in joules) divided by the WTDFIG rating (in VA) is a time duration which is usually a fraction of a cycle at nominal frequency. For example, for the default parameters, ($C=10000 \mu\text{F}$, $V_{\text{dc}}=1200 \text{ V}$, $P_n=1.67 \text{ MVA}$) this ratio $(1/2 \times C \times V_{\text{dc}}^2)/(P_n)$ is 4.3 ms, which represents 0.26 cycle for a 60 Hz frequency. If you change the default values of the nominal power rating and DC voltage, you should change the capacitance value accordingly.

Wind Turbine Doubly-Fed Induction Generator (Phasor Type)

Turbine Data Parameters

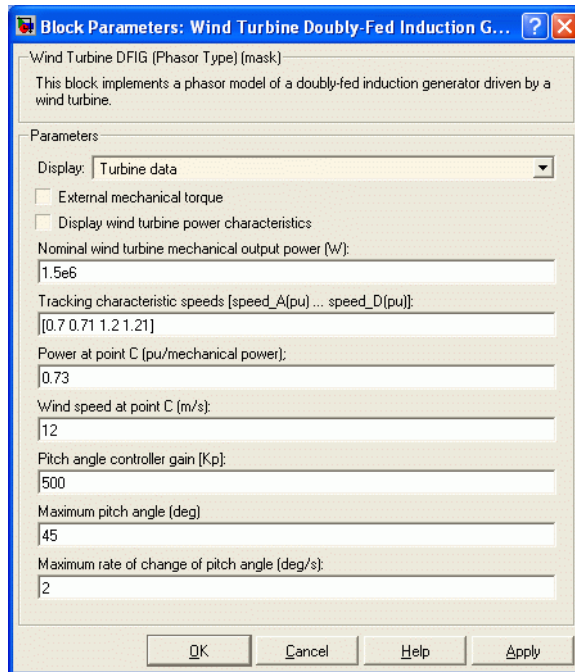

External mechanical torque

If this parameter is checked, a Simulink input named T_m appears on the block, allowing to use an external signal for the generator input mechanical torque. This external torque must be in p.u. based on the nominal electric power and synchronous speed. For example, the external torque may come from a user defined turbine model. Following the convention used in the induction machine, the torque must be negative for power generation.

Electric Power-Speed characteristic

This parameter is visible only when the **External mechanical torque** parameter is checked. It is used to specify a series of speed-power pairs for the tracking characteristic. The speed is in p.u. based on synchronous speed and the power is in p.u. based on nominal generator power.

Wind Turbine Doubly-Fed Induction Generator (Phasor Type)

Display wind turbine power characteristics

If this parameter is checked, the turbine power characteristics at zero degree of pitch angle are displayed for different wind speeds. The tracking characteristic is also displayed on the same figure.

This parameter is not visible when the **External mechanical torque** parameter is checked.

Nominal wind turbine mechanical output power

This parameter is not visible when the **External mechanical torque** parameter is checked.

The nominal turbine mechanical output power in watts.

Tracking characteristic speeds

This parameter is not visible when the **External mechanical torque** parameter is checked.

Specify the speeds of point A to point D of the tracking characteristic in p.u. of the synchronous speed. speed_B must be greater than speed_A and speed_D must be greater than speed_C.

Power at point C

This parameter is not visible when the **External mechanical torque** parameter is checked.

Specify the power of point C of the tracking characteristic in p.u. of the **Nominal wind turbine mechanical output power**.

Wind speed at point C

This parameter is not visible when the **External mechanical torque** parameter is checked.

Specify wind speed in m/s for point C. The power at point C is the maximum turbine output power for the specified wind speed.

Pitch angle controller gain [Kp]

This parameter is not visible when the **External mechanical torque** parameter is checked.

Wind Turbine Doubly-Fed Induction Generator (Phasor Type)

Proportional gain K_p of the pitch controller. Specify K_p in degrees/(speed deviation p.u.). The speed deviation is the difference between actual speed and speed of point D in p.u. of synchronous speed.

Maximum pitch angle

This parameter is not visible when the **External mechanical torque** parameter is checked.

The maximum pitch angle in degrees.

Maximum rate of change of pitch angle

This parameter is not visible when the **External mechanical torque** parameter is checked.

The maximum rate of change of the pitch angle in degrees/s.

Wind Turbine Doubly-Fed Induction Generator (Phasor Type)

Control Parameters

Block Parameters: Wind Turbine Doubly-Fed Induction G... [?] [X]

Wind Turbine DFIG (Phasor Type) (mask)
This block implements a phasor model of a doubly-fed induction generator driven by a wind turbine.

Parameters

Display: Control parameters

Mode of operation: Voltage regulation

External grid voltage reference

Reference grid voltage V_{ref} (pu):
1.0

External reactive current I_{q_ref} for grid-side converter

Grid-side converter generated reactive current reference (I_{q_ref}) (pu):
0

Grid voltage regulator gains [Kp Ki]:
[1.25 300]

Droop X_s (p.u.):
0.02

Power regulator gains [Kp Ki]:
[1 100]

DC bus voltage regulator gains [Kp Ki]:
[0.002 0.05]

Grid-side converter current regulator gains [Kp Ki]:
[1 100]

Rotor-side converter current regulator gains [Kp Ki]:
[0.3 8]

Maximum rate of change of reference grid voltage (p.u./s):
100

Maximum rate of change of reference power (p.u./s):
1

Maximum rate of change of converter reference currents (p.u./s):
200

OK Cancel Help Apply

Mode of operation

Specifies the **WTDFIG** mode of operation. Select either Voltage regulation or Var regulation.

External grid voltage reference

This parameter is not visible when the **Mode of operation** parameter is set to Var regulation.

Wind Turbine Doubly-Fed Induction Generator (Phasor Type)

If this parameter is checked, a Simulink input named V_{ref} appears on the block, allowing to control the reference voltage from an external signal in p.u. Otherwise a fixed reference voltage is used, as specified by the parameter below.

Reference grid voltage V_{ref}

This parameter is not visible when the **Mode of operation** parameter is set to **Var regulation** or when the **External grid voltage reference** parameter is checked.

Reference voltage, in p.u., used by the voltage regulator.

External generated reactive power reference

This parameter is not visible when the **Mode of operation** parameter is set to **Voltage regulation**.

If this parameter is checked, a Simulink input named Q_{ref} appears on the block, allowing to control the reference reactive power, at grid terminals, from an external signal in p.u. Otherwise a fixed reference reactive power is used, as specified by the parameter below.

Generated reactive power Q_{ref}

This parameter is not visible when the **Mode of operation** parameter is set to **Voltage regulation** or when the **External generated reactive power reference** parameter is checked.

Reference generated reactive power at grid terminals, in p.u., used by the var regulator.

External reactive current I_{q_ref} for grid-side converter reference

If this parameter is checked, a Simulink input named I_{q_ref} appears on the block, allowing to control the grid-side converter reactive current from an external signal in p.u. Specify a positive value for I_{q_ref} for generated reactive power. Otherwise a fixed reactive current is used, as specified by the parameter below.

Grid-side converter generated reactive current reference (I_{q_ref})

This parameter is not visible when the **External reactive current I_{q_ref} for grid-side converter reference** parameter is checked.

Reference grid-side converter reactive current, in p.u., used by the current regulator. Specify a positive value of I_{q_ref} for generated reactive power.

Wind Turbine Doubly-Fed Induction Generator (Phasor Type)

Grid voltage regulator gains [Kp Ki]

This parameter is not visible when the **Mode of operation** parameter is set to Var regulation.

Gains of the AC voltage regulator. Specify proportional gain K_p in (p.u. of I)/(p.u. of V), and integral gain K_i , in (p.u. of I)/(p.u. of V)/s, where V is the AC voltage error and I is the output of the voltage regulator.

Droop Xs

This parameter is not visible when the **Mode of operation** parameter is set to Var regulation.

Droop reactance, in p.u./nominal power, defining the slope of the V-I characteristic.

Reactive power regulator gains [Kp Ki]

This parameter is not visible when the **Mode of operation** parameter is set to Voltage regulation.

Gains of the var regulator. Specify proportional gain K_p in (p.u. of I)/(p.u. of Q), and integral gain K_i , in (p.u. of I)/(p.u. of Q)/s, where Q is the reactive power error and I is the output of the var regulator.

Power regulator gains [Kp Ki]

Gains of the power regulator. Specify proportional gain K_p in (p.u. of I)/(p.u. of P), and integral gain K_i , in (p.u. of I)/(p.u. of P)/s, where P is the power error and I is the output of the power regulator.

DC bus voltage regulator gains [Kp Ki]

Gains of the DC voltage regulator which controls the voltage across the DC bus capacitor. Specify proportional gain K_p in (p.u. of I)/(Vdc), and integral gain K_i , in (p.u. of I)/(Vdc)/s, where Vdc is the DC voltage error and I is the output of the voltage regulator.

Grid-side converter current regulator gains [Kp Ki]

Gains of the grid-side converter current regulator.

Specify proportional gain K_p in (p.u. of V)/(p.u. of I) and integral gain K_i , in (p.u. of V)/(p.u. of I)/s, where V is the output V_{gc} of the current regulator and I is the current error.

Wind Turbine Doubly-Fed Induction Generator (Phasor Type)

Rotor-side converter current regulator gains [Kp Ki]

Gains of the rotor-side converter current regulator.

Specify proportional gain K_p in (p.u. of V)/(p.u. of I) and integral gain K_i , in (p.u. of V)/(p.u. of I)/s, where V is the output V_r of the current regulator and I is the current error.

Maximum rate of change of reference grid voltage

This parameter is not visible when the **Mode of operation** parameter is set to Var regulation.

Maximum rate of change of the reference voltage, in p.u./s, when an external reference voltage is used.

Maximum rate of change of reference reactive power

This parameter is not visible when the **Mode of operation** parameter is set to Voltage regulation.

Maximum rate of change of the reference reactive power, in p.u./s, when an external reference reactive power is used.

Maximum rate of change of reference power

Maximum rate of change of the reference power in p.u./s.

Maximum rate of change of converters reference current

Maximum rate of change of the reference current in p.u./s for both the rotor-side and the grid-side converters.

Inputs and Outputs

A B C

The three terminals of the WTDFIG.

Trip

Apply a simulink logical signal (0 or 1) to this input. When this input is high the WTDFIG is disconnected and its control system is disabled. Use this input to implement a simplified version of the protection system.

Wind (m/s)

This input is not visible when the **External mechanical torque** parameter is checked.

Simulink input of the wind speed in m/s.

Wind Turbine Doubly-Fed Induction Generator (Phasor Type)

T_m

This input is visible only when the **External mechanical torque** parameter is checked.

Simulink input of the mechanical torque. T_m must be negative for power generation. Use this input when using an external turbine model.

V_{ref}

This input is visible only when the **Mode of operation** parameter is set to Voltage regulation and the **External grid voltage reference** parameter is checked.

Simulink input of the external reference voltage signal.

Q_{ref}

This input is visible only when the **Mode of operation** parameter is set to Var regulation and the **External generated reactive power reference** parameter is checked.

Simulink input of the external reference generated reactive power signal at grid terminals.

I_{q_ref}

This input is visible only when the **External reactive current I_{q_ref} for grid-side converter** parameter is checked.

Simulink input of the external reference grid-side converter reactive current signal.

Wind Turbine Doubly-Fed Induction Generator (Phasor Type)

m

Simulink output vector containing 29 WTDFIG internal signals. These signals can be individually accessed by using the Bus Selector block. They are, in order:

Signal	Signal Group	Signal Names	Definition
1-3	Iabc (cmplx) (pu)	Ia (pu) Ib (pu) Ic (pu)	Phasor currents Ia, Ib, Ic flowing into the WTDFIG terminals in p.u. based on the generator rating.
4-6	Vabc (cmplx) (pu)	Va (pu) Vb (pu) Vc (pu)	Phasor voltages (phase to ground) Va, Vb, Vc at the WTDFIG terminals in p.u. based on the generator rating.
7-8	Vdq_stator (pu)	Vd_stator (pu) Vq_stator (pu)	Direct-axis and quadrature-axis component of stator voltage in p.u. based on the generator rating. Vd_stator and Vq_stator are respectively the real and imaginary parts of the positive-sequence stator phasor voltage.
9-11	Iabc_stator (cmplx) (pu)	Ia_stator (pu) Ib_stator (pu) Ic_stator (pu)	Phasor currents Ia, Ib, Ic flowing into the stator in p.u. based on the generator rating.

Wind Turbine Doubly-Fed Induction Generator (Phasor Type)

Signal	Signal Group	Signal Names	Definition
12-13	Idq_stator (pu)	Id_stator (pu) Iq_stator (pu)	Direct-axis and quadrature-axis component of stator current in p.u. based on the generator rating. Id_stator and Iq_stator are respectively the real and imaginary parts of the positive-sequence stator phasor current.
14-15	Vdq_rotor (pu)	Vd_rotor (pu) Vq_rotor (pu)	Direct-axis and quadrature-axis component of rotor voltage in p.u. based on the generator rating. Vd_rotor and Vq_rotor are respectively the real and imaginary parts of the positive-sequence rotor phasor voltage.
16-17	Idq_rotor (pu)	Id_rotor (pu) Iq_rotor (pu)	Direct-axis and quadrature-axis component of currents flowing into the rotor in p.u. based on the generator rating. Id_rotor and Iq_rotor are respectively the real and imaginary parts of the positive-sequence rotor phasor current.
18		wr (pu)	Generator rotor speed (p.u.)
19		Tm (pu)	Mechanical torque applied to the generator (p.u.)

Wind Turbine Doubly-Fed Induction Generator (Phasor Type)

Signal	Signal Group	Signal Names	Definition
20		Te (pu)	Electromagnetic torque in p.u. based on the generator rating.
21-22	Vdq_grid_conv v (pu)	Vd_grid_conv (pu) Vq_grid_conv (pu)	Direct-axis and quadrature-axis component of grid-side converter voltage in p.u. based on the generator rating. Vd_grid_conv and Vq_grid_conv are respectively the real and imaginary parts of the grid-side converter phasor voltage.
23-25	Iabc_grid_conv v (cmplx) (pu)	Ia_grid_conv (pu) Ib_grid_conv (pu) Ic_grid_conv (pu)	Phasor currents Ia, Ib, Ic flowing into the grid-side converter in p.u. based on the generator rating.
26		P (pu)	WTDFIG output power. A positive value indicates power generation.
27		Q (pu)	WTDFIG output reactive power. A positive value indicates reactive power generation.
28		Vdc (V)	DC voltage (V).
29		Pitch_angle (deg)	Blade pitch angle in degrees.

Wind Turbine Doubly-Fed Induction Generator (Phasor Type)

Example

See the power_wind_dfig demo which illustrates the steady-state and dynamic performance of the WTDFIG in a 9 MW Wind Farm connected on a 25 kV, 60 Hz, system.

References

- [1] R. Pena, J.C. Clare, G.M. Asher, "Doubly fed induction generator using back-to-back PWM converters and its application to variable-speed wind-energy generation," IEE Proc.-Electr. Power Appl., Vol. 143, No. 3, May 1996
- [2] Vladislav Akhmatov, "Variable-Speed Wind Turbines with Doubly-Fed Induction Generators, Part I: Modelling in Dynamic Simulation Tools," Wind Engineering Volume 26, No. 2, 2002
- [3] Nicholas W. Miller, Juan J. Sanchez-Gasca, William W. Price, Robert W. Delmerico, "DYNAMIC MODELING OF GE 1.5 AND 3.6 MW WIND TURBINE-GENERATORS FOR STABILITY SIMULATIONS," GE Power Systems Energy Consulting, IEEE WTG Modeling Panel, Session July 2003

See Also

Wind Turbine, Wind Turbine Induction Generator (Phasor Type)

Wind Turbine Induction Generator (Phasor Type)

Purpose

Implement a phasor model of a squirrel-cage induction generator driven by a variable pitch wind turbine.

Library

Distributed Resources/Wind Generation

Description

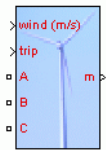

The wind turbine and the induction generator (WTIG) are shown below. The stator winding is connected directly to the grid and the rotor is driven by the wind turbine. The power captured by the wind turbine is converted into electrical power by the induction generator and is transmitted to the grid by the stator winding. The pitch angle is controlled in order to limit the generator output power to its nominal value for high wind speeds. In order to generate power the induction generator speed must be slightly above the synchronous speed. But the speed variation is typically so small that the WTIG is considered to be a fixed-speed wind generator. The reactive power absorbed by the induction generator is provided by the grid or by some devices like capacitor banks, SVC, STATCOM or synchronous condenser.

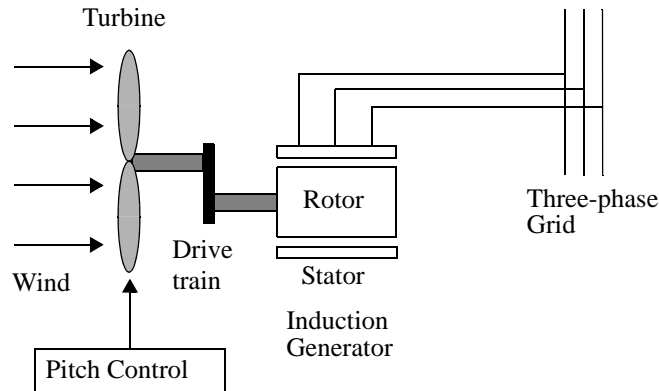

Pitch Angle Control System

The wind turbine model uses the Wind Turbine block of the Distributed Resources/Wind Generation library. See documentation of this block for details.

A Proportional-Integral (PI) controller is used to control the blade pitch angle in order to limit the electric output power to the nominal mechanical power.

Wind Turbine Induction Generator (Phasor Type)

The pitch angle is kept constant at zero degree when the measured electric output power is under its nominal value. When it increases above its nominal value the PI controller increases the pitch angle to bring back the measured power to its nominal value. The control system is illustrated in the figure below:

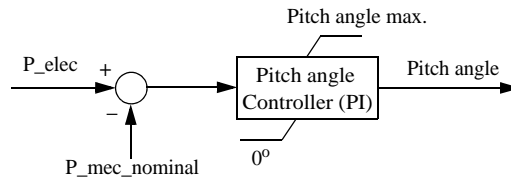

Dialog Box and Parameters

The WTIG parameters are grouped in two categories: Generator data and Turbine data». Use the Display listbox to select which group of parameters you want to visualize.

Generator Data Parameters

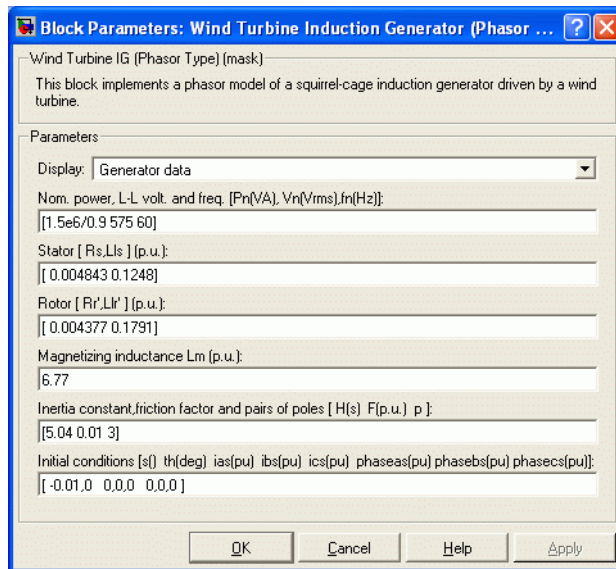

Wind Turbine Induction Generator (Phasor Type)

Nominal power, line-to-line voltage and frequency

The nominal power in VA, the nominal line-to-line voltage in V_{rms} and the nominal system frequency in hertz.

Stator [R_s , L_{ls}]

The stator resistance R_s and leakage inductance L_{ls} in p.u. based on the generator ratings.

Rotor [R_r' , L_{lr}']

The rotor resistance R_r' and leakage inductance L_{lr}' , both referred to the stator, in p.u. based on the generator ratings.

Magnetizing inductance L_m

The magnetizing inductance L_m in p.u. based on the generator ratings.

Inertia constant, friction factor and pairs of poles

Combined generator and turbine inertia constant H in seconds, combined viscous friction factor F in p.u. based on the generator ratings and number of pole pairs p .

You may need to use your own turbine model, in order for example, to implement different power characteristics or to implement the shaft stiffness. Your model must then output the mechanical torque applied to the generator shaft. If the inertia and the friction factor of the turbine are implemented inside the turbine model you specify only the generator inertia constant H and the generator friction factor F .

Initial conditions

The initial slip s , electrical angle θ in degrees, stator current magnitude in p.u. and phase angle in degrees.

Wind Turbine Induction Generator (Phasor Type)

Turbine Data Parameters

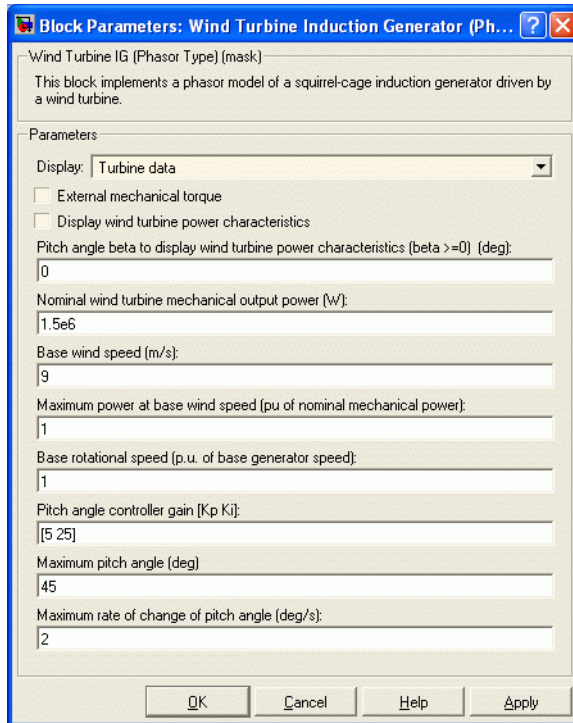

Refer to the Wind Turbine for a detailed documentation.

External mechanical torque

If this parameter is checked, a Simulink input named T_m appears on the block, allowing to use an external signal for the generator input mechanical torque. This external torque must be in p.u. based on the nominal electric power and synchronous speed of the generator. For example, the external torque may come from a user defined turbine model. By convention for the induction machine, the torque must be negative for power generation.

Display wind turbine power characteristics

If this parameter is checked, the turbine power characteristics at the specified pitch angle are displayed for different wind speeds.

Wind Turbine Induction Generator (Phasor Type)

This parameter is not visible when the **External mechanical torque** parameter is checked.

Nominal wind turbine mechanical output power

This parameter is not visible when the **External mechanical torque** parameter is checked.

The nominal turbine mechanical output power in watts.

Base wind speed

This parameter is not visible when the **External mechanical torque** parameter is checked.

The base value of the wind speed, in m/s, used in the per unit system. The base wind speed is the mean value of the expected wind speed. This base wind speed produces a mechanical power which is usually lower than the turbine nominal power.

Maximum power at base wind speed

This parameter is not visible when the **External mechanical torque** parameter is checked.

The maximum power at base wind speed in p.u. of the nominal mechanical power.

Base rotational speed

This parameter is not visible when the **External mechanical torque** parameter is checked.

The rotational speed at maximum power for the base wind speed. The base rotational speed is in p.u. of the base generator speed.

Pitch angle controller gain [Kp Ki]

This parameter is not visible when the **External mechanical torque** parameter is checked.

Proportional and Integral gains K_p and K_i of the pitch controller. Specify K_p in degrees/(power deviation p.u.) and K_i in degrees/(power deviation p.u.)/s. The power deviation is the difference between actual electrical output power and the nominal mechanical power in p.u. of the generator nominal power.

Wind Turbine Induction Generator (Phasor Type)

Maximum pitch angle (deg)

This parameter is not visible when the **External mechanical torque** parameter is checked.

The maximum pitch angle in degrees.

Maximum rate of change of pitch angle

This parameter is not visible when the **External mechanical torque** parameter is checked.

The maximum rate of change of the pitch angle in degrees/s.

Inputs and Outputs

A B C

The three terminals of the WTIG.

Trip

Apply a simulink logical signal (0 or 1) to this input. When this input is high the WTIG is disconnected. Use this input to implement a simplified version of the protection system.

Wind (m/s)

This input is not visible when the **External mechanical torque** parameter is checked.

Simulink input of the wind speed in m/s.

Tm

This input is visible only when the **External mechanical torque** parameter is checked.

Simulink input of the mechanical torque. Tm must be negative for power generation. Use this input when using an external turbine model.

Wind Turbine Induction Generator (Phasor Type)

m

Simulink output vector containing 8 WTIG internal signals. These signals can be individually accessed by using the Bus Selector block. They are, in order:

Signal	Signal Names	Definition
1	Vabc (cmplx) (pu)	Phasor voltages (phase to ground) Va, Vb, Vc at the WTIG terminals in p.u. based on the generator ratings.
2	Iabc (cmplx) (pu)	Phasor currents Ia, Ib, Ic flowing into the WTIG terminals in p.u. based on the generator ratings.
3	P (pu)	WTIG output power in p.u. based on the generator ratings. A positive value indicates power generation.
4	Q (pu)	WTIG output reactive power in p.u. based on the generator ratings. A positive value indicates reactive power generation.
5	wr (pu)	Generator rotor speed (p.u.)
6	Tm (pu)	Mechanical torque applied to the generator in p.u. based on the generator ratings.
7	Te (pu)	Electromagnetic torque in p.u. based on the generator ratings.
8	Pitch_angle (deg)	Blade pitch angle in degrees.

Example

See the power_wind_ig demo which illustrates the steady-state and dynamic performance of the WTIG. Three WTIG blocks are used to simulate a 9 MW wind farm connected in a 25 kV, 60 Hz, system. Voltage regulation is performing by a 3 Mvar STATCOM.

Wind Turbine Induction Generator (Phasor Type)

References

[1] Siegfried Heier, "Grid Integration of Wind Energy Conversion Systems," John Wiley & Sons Ltd, 1998, ISBN 0-471-97143-X

See Also

Wind Turbine, Wind Turbine Doubly-Fed Induction Generator (Phasor Type)

Zigzag Phase-Shifting Transformer

Purpose Implement a zigzag phase-shifting transformer with a configurable secondary winding connection

Library Elements

Description

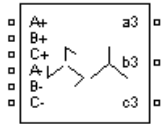

The Zigzag Phase-Shifting Transformer block implements a three-phase transformer with a primary winding connected in a zigzag configuration and a configurable secondary winding. The model uses three single-phase, three-winding transformers. The primary winding connects the windings 1 and 2 of the single-phase transformers in a zigzag configuration. The secondary winding uses the windings 3 of the single phase transformers, and they can be connected in one of the following ways:

- Y
- Y with accessible neutral
- Grounded Y
- Delta (D1), delta lagging Y by 30 degrees
- Delta (D11), delta leading Y by 30 degrees

Note The D1 and D11 notations refer to the following clock convention. It assumes that the reference Y voltage phasor is at noon (12) on a clock display. D1 and D11 refer respectively to 1 PM (lagging Y by -30 degrees) and 11 AM (leading Y by $+30$ degrees).

If the secondary winding is connected in Y, the secondary phase voltages are leading or lagging the primary voltages by the Φ phase angle specified in the parameters of the block. If the secondary winding is connected in delta (D11), an additional phase shift of $+30$ degrees is added to the phase angle. If the secondary winding is connected in delta (D1), a phase shift of -30 degrees is added to the phase angle.

The block takes into account the connection type you have selected and the icon of the block is automatically updated. An output port labeled N is added to the block if you select the Y connection with accessible neutral for the secondary winding.

Zigzag Phase-Shifting Transformer

The saturation characteristic, when activated, is the same as the one described for the Saturable Transformer block.

Dialog Box and Parameters

Block Parameters: Zigzag Phase-Shifting Transformer

Zigzag Phase-Shifting Transformer (mask) (link)

This block implements a three-phase phase-shifting transformer by using three single-phase three-winding transformers. Primary consists of windings 1 and 2 connected in zig-zag. All primary terminals are accessible. Secondary (winding 3) can be connected in wye or delta.

Click the Apply or the OK button after a change to the Units popup to confirm the conversion of parameters.

Parameters

Units: pu

Nominal power and frequency [Pn(VA) fn (Hz)]:
[100e6 60]

Primary (zig-zag) nominal voltage Vp (VrmsPh-Ph):
10e3

Secondary nom. voltage phase shift [V3(VrmsPh-Ph) Phi(Deg)]:
[30e3 +15]

Secondary winding (abc) connection: Y

Winding 1 (zig-zag): [R1(pu) L1(pu)]:
[0.002 0.08]

Winding 2 (zig-zag): [R2(pu) L2(pu)]:
[0.002 0.08]

Winding 3 (secondary): [R3(pu) L3(pu)]:
[0.002 0.08]

Saturable core

Magnetization resistance Rm (pu)
500

Saturation characteristic (pu) [i1 , phi1 ; i2 , phi2 ; ...]
[0,0 ; 0.0024,1.2 ; 1,0,1.52]

Measurements: None

..... Show additional parameters

Break Algebraic loop in discrete saturation model

OK Cancel Help Apply

Units

Specify the units used to enter the parameters of the Zigzag Phase-Shifting Transformer block. Select pu to use per unit. Select SI to use SI units. Changing the **Units** parameter from pu to SI, or from SI to pu, will automatically convert the parameters displayed in the mask of the block.

Zigzag Phase-Shifting Transformer

Nominal power and frequency

The nominal power rating, in volt-amperes (VA), and nominal frequency, in hertz (Hz), of the transformer.

Primary (zigzag) nominal voltage V_p

The phase-to-phase nominal voltage in volts RMS, for the primary winding of the transformer.

Secondary nominal voltage and phase shift

The phase-to-phase nominal voltage, in volts RMS, and the phase shift, in degrees, for the secondary winding of the transformer.

Secondary winding (abc) connection

The winding connection for the secondary winding.

Winding 1 (zigzag): [R1 L1]

The resistance and leakage inductance of the windings 1 of the single-phase transformers used to implement the primary winding of the Zigzag Phase-Shifting Transformer.

Winding 2 (zigzag): [R2 L2]

The resistance and leakage inductance of the windings 2 of the single-phase transformers used to implement the primary winding of the Zigzag Phase-Shifting Transformer.

Winding 3 (secondary): [R1 L1]

The resistance and leakage inductance of the windings 3 of the single-phase transformers used to implement the secondary winding of the Zigzag Phase-Shifting Transformer.

Saturable core

If selected, implements a saturable core.

Magnetization resistance R_m

This parameter is visible only if the **Saturable core** check box is selected.

The magnetization resistance R_m , in p.u, when the saturation is simulated.

Zigzag Phase-Shifting Transformer

Magnetizing branch: [Rm(p.u.) Lm(p.u.)]

The **Magnetizing branch** parameter is not visible in the dialog box if the **Saturable core** check box is selected.

The magnetization resistance R_m and inductance L_m , in p.u., when the saturation is not simulated.

Saturation characteristic

This parameter is visible only if the **Saturable core** check box is selected.

The saturation characteristic for the saturable core. Specify a series of current/ flux pairs (in p.u.) starting with the pair (0,0).

Measurements

Select **Winding voltages** to measure the voltage across the winding terminals of the Three-Phase Transformer block.

Select **Winding currents** to measure the current flowing through the windings of the Three-Phase Transformer block.

Select **Fluxes** and excitation currents ($I_m + I_{Rm}$) to measure the flux linkage, in volt-seconds (V.s), and the total excitation current including iron losses modeled by R_m (for saturable transformers only).

Select **Fluxes** and magnetization currents (I_m) to measure the flux linkage, in volt-seconds (V.s), and the magnetization current, in amperes (A), not including iron losses modeled by R_m (for saturable transformers only).

Select **All measurements** (V, I, Flux) to measure the winding voltages, currents, magnetization currents, and the flux linkages.

Place a **Multimeter** block in your model to display the selected measurements during the simulation. In the **Available Measurements** list box of the Multimeter block, the measurements are identified by a label followed by the block name.

Zigzag Phase-Shifting Transformer

The labels used in the Multimeter are as follows.

Measurement	Label
Winding voltages of primary (zigzag)	Uprim_A:, Uprim_B:, Uprim_C:
Winding currents of primary (zigzag)	Iprim_A:, Iprim_B:, Iprim_C:
Winding voltages of secondary (Y, Yn, or Yg)	Usec_A:, Usec_B:, Usec_C:
Winding voltages of secondary (delta)	Usec_AB:, Usec_BC:, Usec_CA:
Winding currents of secondary (Y, Yn, or Yg)	Isec_A:, Isec_B:, Isec_C:
Winding currents of secondary (delta)	Isec_AB:, Isec_BC:, Isec_CA:
Fluxes (windings 1 of zigzag)	Flux_A:, Flux_B:, Flux_C:
Excitation currents (windings 1 of zigzag)	Iexc_A:, Iexc_B:, Iexc_C:
Magnetization currents (windings 1 of zigzag)	Imag_A:, Imag_B:, Imag_C:

Example

See the help text of the power_48pulsegtoconverter demo.

In this model, a 48-pulse GTO converter is built with four Three-Level Bridge blocks and four Zigzag Phase-Shifting Transformer blocks. Harmonic neutralization is obtained by use of appropriate phase shifts introduced by the Zigzag connections (+7.5/-7.5 degrees) and of secondary winding connections (Y or Delta).

See Also

Multimeter, Three-Phase Transformer (Three Windings)

SimPowerSystems Command Reference

Commands – Alphabetical List

This table indicates the tasks performed by the commands described in this chapter.

Command	Purpose
<code>power_analyze</code>	Analyze an electric circuit built with SimPowerSystems
<code>power_init</code>	Set the initial states values of an electrical circuit
<code>power_lineparam</code>	Compute the RLC parameters of an overhead transmission line from its conductor characteristics and tower geometry
<code>power_statespace</code>	Compute the linear state-space model of an electrical circuit

Purpose	Analyze electric circuit built with SimPowerSystems
Syntax	<pre>sps = power_analyze('sys', 'structure') sps = power_analyze('sys', 'sort') sps = power_analyze('sys', 'ss') [A,B,C,D,x0,states,inputs,outputs,uss,xss,yss,freqyss,Hlin]= power_analyze('sys'); power_analyze('sys', 'net')</pre>
Description	<p>The <code>power_analyze</code> command computes the equivalent state-space model of the specified electrical model built with SimPowerSystems. It evaluates the A, B, C, D standard matrices of the state-space system described by the equations</p> $\dot{x} = Ax + Bu$ $y = Cx + Du$ <p>where the state variables contained in the x vector are the inductor currents and capacitor voltages. Nonlinear elements are simulated by current sources driven by the voltages across the nonlinear elements.</p> <p>The inputs of the system contained in the u vector are the voltage and current sources plus the current sources simulating the nonlinear elements. The outputs of the system contained in the y vector are the voltage and current measurements plus the voltages across the nonlinear elements.</p> <p>The following conventions are used for inputs:</p> <ul style="list-style-type: none"> • Source current flowing in the arrow direction is positive. • Positive source voltage is indicated by a + sign on the icon. <p>The sign conventions used for voltages and currents (state variables x and measurement outputs y) are explained below.</p> <p>Sign Conventions for Voltages and Currents</p> <p>When you measure a current using a Current Measurement block, the positive direction of current is indicated on the block icon (positive current flowing from + terminal to – terminal). Similarly, when you measure a voltage using a Voltage Measurement block, the measured voltage is the voltage of the + terminal with respect to the – terminal. However, when voltages and currents of blocks from the Elements library are measured using the Multimeter block,</p>

the voltage and current polarities are not so evident because blocks might have been rotated and there are no signs indicating polarities on the block icons.

Unlike the Simulink signal lines and input and output ports, the Physical Modeling connection lines and terminal ports of SimPowerSystems lack an intrinsic direction. The voltage and current polarities are determined instead by the block orientation. To find out the block orientation, first click the block to select it. Then enter the following command:

```
get_param(gcf, 'Orientation')
```

The following table gives the polarities of the currents and voltages measured with the Multimeter block for single-phase and three-phase RLC elements (branches or loads), surge arresters, and single-phase and three-phase breakers. The table also indicates the polarities of the corresponding state variables (inductor currents and capacitor voltages).

Block Orientation	Positive Current Direction	Measured Voltage
right	left → right	Vleft – Vright
left	right → left	Vright – Vleft
down	top → bottom	Vtop – Vbottom
up	bottom → top	Vbottom – Vtop

The natural orientation of the blocks (that is, their orientation in the Element library) is *right* for horizontal blocks and *down* for vertical blocks.

For single-phase transformers (linear or saturable), with the winding ports appearing on the left and right sides, the winding voltages are the voltages of the top terminal port with respect to the bottom terminal port, whatever the block orientation (*right* or *left*). The winding currents are the currents entering the top port.

For three-phase transformers, the voltage polarities and positive current directions are indicated by the signal labels used in the Multimeter block. For example, Uan_w2 = phase A-to-neutral voltage of the Y connected winding #2,

Iab_w1 = winding current flowing from A to B in the delta connected winding #1.

Output Arguments: Structure

sps = power_analyze('sys', 'structure') creates a structure array sps with fields and values describing the model sys.

The fields of the structure array are defined in the following order.

Field	Description
circuit	Name of the model
states	char array of state variable names
inputs	char array of system input names
outputs	char array of system output names
A	nstates-by-nstates state-space <i>A</i> matrix
B	nstates-by-ninput state-space <i>B</i> matrix
C	noutput-by-nstates state-space <i>C</i> matrix
D	noutput-by-ninput state-space <i>D</i> matrix
x0	nstates-by-1 vector of initial conditions
Aswitch	<i>A</i> matrix including closed switches
Bswitch	<i>B</i> matrix including closed switches
Cswitch	<i>C</i> matrix including closed switches
Dswitch	<i>D</i> matrix including closed switches
x0switch	Vector of initial values of switch currents
uss	ninput-by-nfreq steady-state values of inputs
xss	nstates-by-nfreq steady-state values of states
yss	noutput-by-nfreq steady-state values of outputs

Field (Continued)	Description (Continued)
Hlin	nfreq-by-noutput-by-ninput transfer function of impedances
frequencies	1-by-nfreq vector of input source frequencies
LoadFlow	Load flow information for circuits with machines
OscillatoryModes	Oscillatory modes of linear part of the system

The table uses the following conventions:

- `nstates` is the number of states.
- `ninput` is the number of inputs.
- `noutput` is the number of outputs.
- `nfreq` is the number of input source frequencies.

`states` is a string matrix containing names of the state variables. Each line of `states` begins with a prefix `Uc_` for capacitor voltages or `I1_` for inductor currents, followed by the name of the block in which the element (C or L) is found. See “Sign Conventions for Voltages and Currents” on page 8-43 for inductor current directions and capacitor voltage polarities. A string is added to this prefix for blocks containing more than two inductances or capacitors. For example, the Linear Transformer blocks produce four lines in the `states` matrix, one for each of the three leakage inductances, with prefixes `I1_winding_x:`, where `x` is the winding number of the transformer, and one line for the magnetization inductance with the prefix `I1_Lm:`.

`inputs` is a string matrix containing names of the inputs of the system. Each line of `inputs` begins with a prefix `U_` for voltage sources or `I_` for current sources, followed by the name of the source block. A string can be added to the prefix for blocks containing more than one source. For example, the Synchronous Machine block produces two current inputs with prefixes `I_A:` and `I_B:` (phase A and phase B machine currents).

`outputs` is a string matrix containing names of the outputs of the state-space system (vector `y`). Each line of `outputs` begins with a prefix `U_` for voltage outputs or `I_` for current outputs, followed by the name of the block that produces the output. A string can be added to the prefix for blocks containing

more than one source. For example, the Synchronous Machine block produces two voltage outputs with prefixes U_AB: and U_BC: (two machine phase-to-phase voltages). See “Sign Conventions for Voltages and Currents” on page 8-43 for current directions and voltage polarities.

A, B, C, D are the state-space matrices of the linear part of the model.

x0 is a vector containing the initial conditions of the state variables listed in the states variable.

uss, xss, and yss are complex matrices containing the steady-state values of inputs, states and outputs. If voltage and current sources all generate the same frequency, these are column vectors. If sources with different frequencies are used, each column of the matrices corresponds to a frequency contained in the frequencies vector.

frequencies is a row vector containing the input source frequencies ordered by increasing values.

Hlin is the complex transfer impedance three-dimensional array (nfreq-by-noutput-by-ninput) of the linear system corresponding to the frequencies contained in the frequencies vector. For a particular frequency, Hlin is defined by

$$yss(:, ifreq) = Hlin(ifreq, :, :) * uss(:, ifreq)$$

sps = power_analyze('sys', 'sort') returns a structure array sps with the following fields related to the interconnection of SimPowerSystems blocks in a model. The fields are defined in the following order.

Output Arguments:
Sort

Field	Description
circuit	Name of the model
SampleTime	Sample time for discrete systems
RlcBranch	r1c matrix in the power_statespace format
RlcBranchNames	List of blocks containing the state variable
SourceBranch	Source matrix in the power_statespace format
SourceBranchNames	Names of the blocks defined as sources

power_analyze

Field (Continued)	Description (Continued)
InputNames	Names of the inputs of the system
OutputNames	Names of the outputs of the system
OutputExpressions	Output expression in the power_statespace format
OutputMatrix	Output expression in matrix format (internal)
MeasurementBlocks	Names of the voltage and current measurement blocks

[A,B,C,D,x0,states,inputs,outputs,uss,xss,yss,frequencies,Hlin] = power_analyze('sys') returns the state-space calculations in separate variables.

sps = power_analyze('sys','ss') creates a continuous state-space model of the model sys with matrices *A*, *B*, *C*, *D*. You must have Control System Toolbox installed for this option. The output is a state-space object.

Output Arguments: Net

power_analyze('sys','net') generates a netlist stored in a file, sys.net. The file contains the node numbers automatically generated by power_analyze, as well as parameter values of all linear elements. See the formats described in the power_statespace reference page.

Example

Obtain the state-space matrices and steady-state voltages and currents for the power_netsim2 circuit.

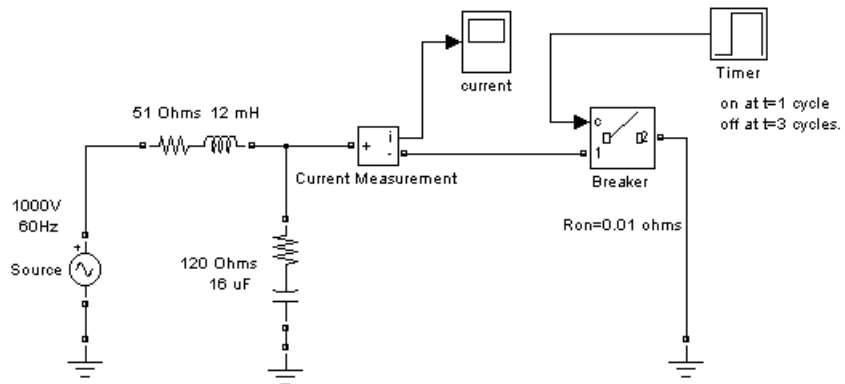

The command

```
sps = power_analyze('power_netsim2','structure')
```

returns the state-space model in the sps structure variable.

```
sps.A =
  1.0e+04 *
      0    6.2500
 -0.0083 -1.4250
```

```
sps.uss =
  0
 1000
```

```
sps.xss =
  1.0e+02 *
  4.8392 - 5.1314i
  0.0310 + 0.0292i
```

```
sps.yss =
  1.0e+02 *
  8.5535 - 1.6287i
  0
```

```
sps.inputs =
```

power_analyze

```
I_Breaker  
U_Source
```

```
sps.outputs =  
    U_Breaker  
    I_Current Measurement
```

The inductor current of the 51-ohm, 12-mH block and the capacitor voltage of the 120-ohm, 16- μ F block are the two state variables in this circuit. The Breaker block is a nonlinear element that is represented by a current source (the first input) driven by the voltage across its terminals (the first output).

See Also

power_statespace, power_init, Powergui

Purpose	Set initial state values of model built with Simulink and SimPowerSystems
Syntax	<pre>[x0,states] = power_init(sys) [x0,states] = power_init(sys,'look') power_init(sys,'states') power_init(sys,'ForceToZero') power_init(sys,'ResetToDefault') power_init(sys,'x0',x0) power_init(sys,'look') power_init(sys,'reset') power_init(sys,'steady')</pre>
Description	<p>Power_init deals with two types of state variables: the Simulink State variables and the Electrical State variables. The Simulink States consists of the entire set of state variables of a model (including the Electrical states) seen by Simulink. The Electrical States are the particular Simulink states that defines the capacitor initial voltages and inductor initial currents of the SimPowerSystems blocks of your model.</p> <p><code>[x0,states] = power_init(sys)</code> returns the initial states values and state names of your model.</p> <p><code>[x0,states] = power_init(sys,'look')</code> returns the electrical initial states values and state names of sys.</p> <p><code>power_init(sys,'states')</code> displays in a two-column format the initial state values and names of your model.</p> <p><code>power_init(sys,'ForceToZero')</code> sets to zero the initial states your model. It uses the Data import/export initial state option of the Simulink Configuration Parameters menu to specify the initial state values. Use the ResetToDefault option of <code>power_init</code> to reset the Simulink configuration parameters to its previous settings.</p> <p><code>power_init(sys,'ResetToDefault')</code> resets the initial state of Simulink Configuration parameters to the settings prior to the use of the ForceToZero option of <code>power_init</code>. This option has no effect on system if the ForceToZero option is not used before.</p> <p><code>power_init(sys,'x0',x0)</code> sets the initial state values equal to the vector specified by x0. The ordering of the states variables is given by the state option</p>

power_init

of `power_init`. This option uses the **Data import/export initial state** option of the Simulink **Configuration Parameters** menu to specify the initial state values.

`power_init(sys, 'look')` displays in a two-column format the electrical initial states names and values of your model.

`power_init(sys, 'reset')` resets the electrical initial states of `sys` to zero.

`power_init(sys, 'steady')` sets the electrical initial states of `sys` to simulate the electrical circuit in the steady state.

See Also

`power_analyze`, `Powergui`

Purpose Compute RLC parameters of overhead transmission line from its conductor characteristics and tower geometry

Synopsis The power_lineparam command opens a graphical user interface (GUI) that is used to enter the line parameters and return the electrical R, L, C line parameters. This GUI can also be activated from the Powergui block dialog box by selecting **Compute RLC Line Parameters**.

Description The power_lineparam function computes the resistance, inductance, and capacitance matrices of an arbitrary arrangement of conductors of an overhead transmission line. For a three-phase line, the symmetrical component RLC values are also computed.

The following figure shows a typical conductor arrangement for a three-phase double-circuit line. This line configuration is used as an example to illustrate the various line parameters to be entered in the GUI.

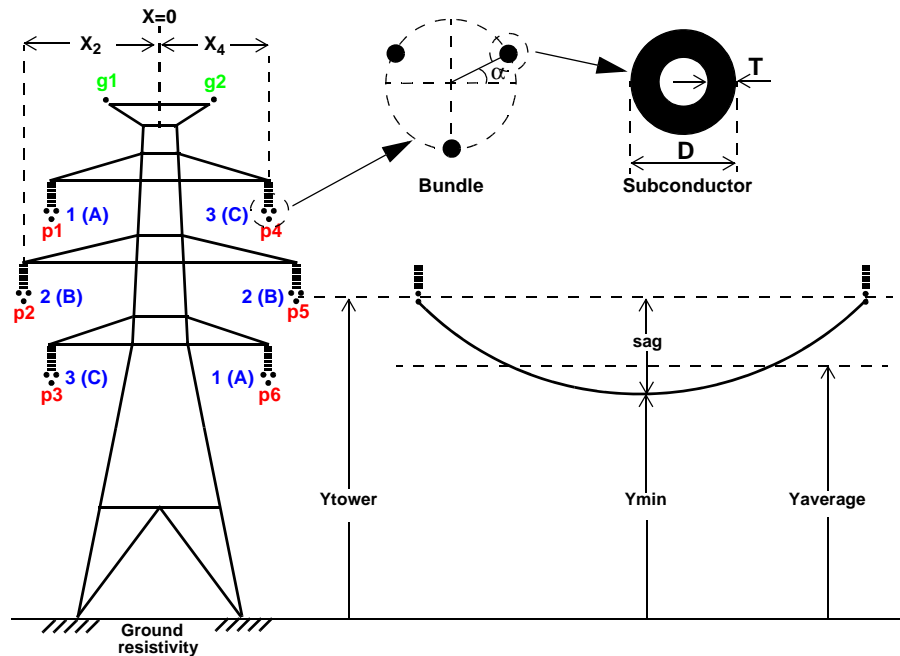

Configuration of a Three-Phase Double-Circuit Line

For a set of N conductors, `power_lineparam` computes three N -by- N matrices: the series resistance and inductance matrices $[R]$ and $[L]$ and the shunt capacitance matrix $[C]$. These matrices are required by the Distributed Parameter Line block for modeling N -phase asymmetrical lines and by the single-phase PI Section Line block. `power_lineparam` also computes the symmetrical component RLC parameters required by the Three-Phase PI Section Line block. For two coupled conductors i and k , the self and mutual terms of the R , L , and C matrices are computed using the concept of image conductors [1]

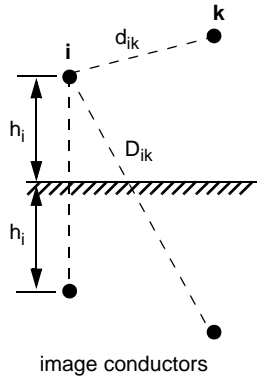

Self and mutual resistance terms:

$$R_{ii} = R_{int} + \Delta R_{ii} \quad \Omega/\text{km}$$

$$R_{ik} = \Delta R_{ik} \quad \Omega/\text{km}$$

Self and mutual inductance terms:

$$L_{ii} = L_{int} + \frac{\mu_0}{2\pi} \cdot \log \frac{2h_i}{r_i} + \Delta L_{ii} \quad \text{H}/\text{km}$$

$$L_{ik} = \frac{\mu_0}{2\pi} \cdot \log \frac{D_{ik}}{d_{ik}} + \Delta L_{ik} \quad \text{H}/\text{km}$$

Self and mutual potential coefficient terms:

$$P_{ii} = \frac{1}{2\pi\epsilon_0} \cdot \log \frac{2h_i}{r_i} \quad \text{km}/\text{F}$$

$$P_{ik} = \frac{1}{2\pi\epsilon_0} \cdot \log \frac{D_{ik}}{d_{ik}} \quad \text{km}/\text{F}$$

$$[C] = [P]^{-1} \quad \text{F}/\text{km}$$

where:

μ_0 : permeability of free space = $4\pi \cdot 10^{-4}$ H/km

ϵ_0 : permittivity of free space = $8.8542 \cdot 10^{-9}$ F/km

r_i : radius of conductor i in meters

d_{ik} : distance between conductors i and k in meters

D_{ik} : distance between conductor i and image of k in meters

h_i : average height of conductor i above ground, in meters

R_{int} , L_{int} : internal resistance and inductance of conductor

ΔR_{ij} , ΔR_{ik} : Carson R correction terms due to ground resistivity

ΔL_{ij} , ΔL_{ik} : Carson L correction terms due to ground resistivity

The conductor self inductance is computed from the magnetic flux circulating inside and outside the conductor, and produced by the current flowing in the conductor itself. The part of flux circulating inside the conducting material contributes to the so called internal inductance L_{int} , which is dependant on the conductor geometry. Assuming a hollow or solid conductor, the internal inductance is computed from the T/D ratio where D is the conductor diameter and T is the thickness of the conducting material (see the figure named “Configuration of a Three-Phase Double-Circuit Line” on page 8-13). The conductor self inductance is computed by means of modified Bessel functions from the conductor diameter, T/D ratio, resistivity, and relative permeability of conducting material and specified frequency [1].

The conductor self inductance can be also computed from parameters that are usually found in tables provided by conductor manufacturers: the Geometric Mean Radius (GMR) or the so called “Reactance at one-foot spacing.”

The GMR is the radius of the equivalent hollow conductor with zero thickness, thus producing no internal flux, giving the same self inductance. The conductor self inductance is then derived from the GMR using the following equation.

$$L_{ii} = \frac{\mu_0}{2\pi} \cdot \log \frac{2h_i}{GMR} + \Delta L_{ii} \quad H/km$$

For a solid conductor (T/D=0.5), the GMR is given by

$$GMR = r \cdot e^{-\mu_r/4}$$

where: r = radius of conductor

μ_r = relative permeability of conducting material

The GMR obtained from the above equation assumes a uniform current density in the conductor. This assumption is strictly valid in DC. In AC, the GMR is slightly higher. For example for a 3 cm diameter solid aluminum conductor ($R_{dc} = 0.040 \Omega/km$), the GMR increases from 1.1682 cm in DC to 1.1784 cm at 60 Hz. Manufacturers usually give the GMR at the system nominal frequency (50 Hz or 60 Hz).

The reactance X_a at 1-foot spacing (or 1-meter spacing if metric units are used) is the positive-sequence reactance of a three-phase line having one foot (or one meter) spacing between the three phases and infinite conductor heights. The

power_lineparam

reactance at one-foot spacing (or 1-meter spacing) at frequency f is related to the GMR by the following equation

$$X_a = \omega \cdot \frac{\mu_0}{2\pi} \cdot \log \frac{1}{GMR} \quad \Omega/\text{km}$$

where: GMR = Geometric Mean Radius in feet or meters

$\omega = 2\pi \cdot f$ in rad/s

f = frequency in hertz

The conductor resistance matrix at a particular frequency depends on the DC resistance of the conductor corrected for skin effect and ground resistivity. In fact, both the resistance matrix and the inductance matrix are dependent on the ground resistivity and frequency. Correction terms for the R and L terms as developed by J.R. Carson in 1926 [2] are implemented in power_lineparam.

When you type the power_lineparam command, the GUI is displayed as shown below.

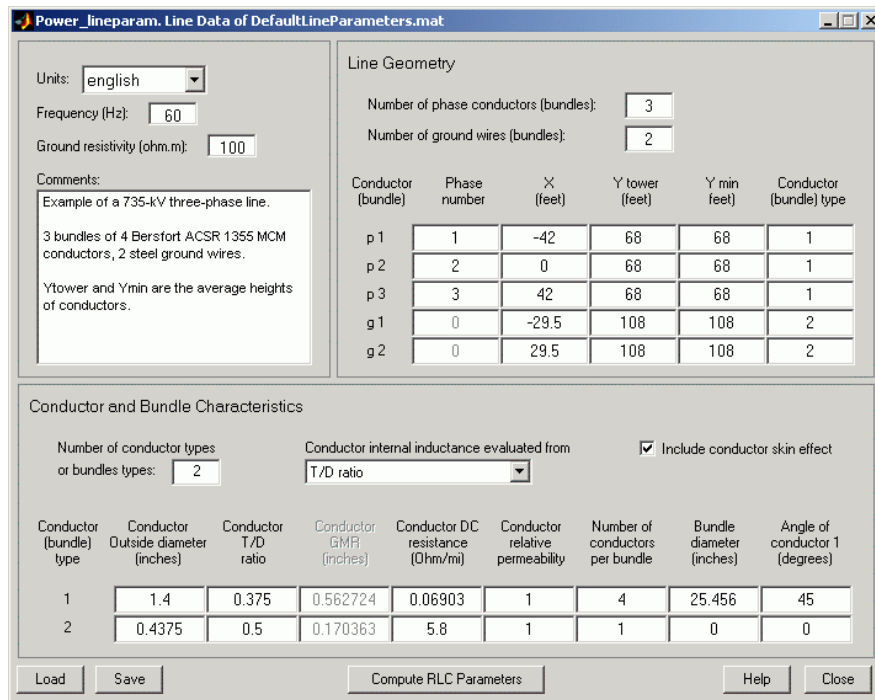

The default parameters are for a single-circuit three-phase line with two ground wires. You enter your own line parameters in three different sections:

- The upper-left section where you enter general parameters (units, frequency, ground resistivity, and comments)
- The table of conductor types defining the conductor characteristics for each type (bottom section)
- The table of conductors specifying the line geometry and the conductor types (upper-right section)

General Parameters

Units

In the pull-down menu, select `metric` if you want to specify conductor diameter, GMR and bundle diameter in centimeters and conductor positions in meters. Select `english` if you want to specify conductor diameter, GMR and bundle diameter in inches and conductor positions in feet.

Frequency

Specify the frequency in hertz to be used to evaluate RLC parameters.

Ground resistivity

Specify the ground resistivity in `ohm.meters`. A zero value (perfectly conducting ground) is allowed.

Comments

Use this window to type comments that you want to save with the line parameters, for example, voltage level, conductor types and characteristics, etc.

Conductor and Bundle Characteristics

Number of conductor types or bundle types

Specify the number of conductor types (single conductor or bundle of subconductors) to be used. This parameter determines the number of rows of the table of conductors types. The phase conductors and ground wires can be either single conductors or bundles of subconductors. For voltage levels of 230 kV and above, phase conductors are usually bundled to reduce losses and electromagnetic interferences due to corona effect. Ground wires are usually not bundled.

For a simple AC three-phase line, single- or double-circuit, there are usually two types of conductors: one type for the phase conductors and one type for the ground wires. More than two types will be necessary for several lines in the same corridor, DC bipolar lines or distribution feeders where neutral and sheaths of TV and telephone cables are represented.

In the table of conductor types, two rows are visible at a time. If more than two conductor types are specified, a scroll bar appears at the right side of the table to give you access to the different rows of the table.

Conductor internal inductance evaluated from

Select one of the following three parameters to specify how the conductor internal inductance is computed: T/D ratio, Geometric Mean Radius (GMR), or Reactance X_a at 1-foot spacing (or 1-meter spacing if the **Units** parameter is set to metric).

If you select T/D ratio, the internal inductance is computed from the T/D value specified in the table of conductors, assuming a hollow or solid conductor, where D is the conductor diameter and T is the thickness of the conducting material (see the figure named “Configuration of a Three-Phase Double-Circuit Line” on page 8-13). The conductor self inductance and resistance are computed from the conductor diameter, T/D ratio, DC resistance, and relative permeability of conducting material and specified frequency.

If you select Geometric Mean Radius (GMR), the conductor GMR is used to evaluate the internal inductance. When the conductor inductance is evaluated from the GMR, the specified frequency does not affect the conductor inductance. You have therefore to provide the manufacturer’s GMR for the desired frequency (usually 50 Hz or 60 Hz). When you are using the T/D ratio option, the corresponding conductor GMR at the specified frequency is displayed.

Selecting Reactance X_a at 1-foot spacing (or 1-meter spacing) uses the positive-sequence reactance at the specified frequency of a three-phase line having 1-foot (or 1-meter) spacing between the three phases to compute the conductor internal inductance.

Include conductor skin effect

Select this check box to include the impact of frequency on conductor AC resistance and inductance (skin effect). If this parameter is not checked,

the resistance is kept constant at the value specified by the **Conductor DC resistance** parameter and the inductance is kept constant at the value computed in DC, using the **Conductor outside diameter** and the **conductor T/D ratio**. When skin effect is included, the conductor AC resistance and inductance are evaluated considering a hollow conductor with T/D ratio (or solid conductor if $T/D = 0.5$). The T/D ratio is used to evaluate the AC resistance even if the conductor inductance is evaluated from the GMR or from the reactance at one-foot spacing or one-meter spacing. The ground skin effect is always considered and it depends on the ground resistivity.

Conductor (bundle) type

Lists the conductor or bundle types by increasing number, starting from 1 and ending at the value specified in the parameter **Number of conductor types or bundle types**. You cannot change this value.

Conductor outside diameter

Specify the conductor outside diameter in centimeters or inches.

Conductor T/D ratio

Specify the T/D ratio of the hollow conductor, where T is the thickness of conducting material and D is the outside diameter. This parameter can vary between 0 and 0.5. A T/D value of 0.5 indicates a solid conductor. For Aluminum Cable Steel Reinforced (ACSR) conductors, you can ignore the steel core and consider a hollow aluminum conductor (typical T/D ratios comprised between 0.3 and 0.4). The T/D ratio is used to compute the conductor AC resistance when the **Include conductor skin effect** parameter is checked. It is also used to compute the conductor self inductance when the parameter **Conductor internal inductance evaluated from** is set to T/D ratio.

Conductor GMR

This parameter is accessible only when the parameter **Conductor internal inductance evaluated from** is set to Geometric Mean Radius (GMR). Specify the GMR in centimeters or inches. The GMR at 60 Hz or 50 Hz is usually provided by conductor manufacturers. When the parameter **Conductor internal inductance evaluated from** is set to T/D ratio, the value of the corresponding GMR giving the same conductor inductance is displayed. When the parameter **Conductor internal inductance**

evaluated from is set to Reactance X_a at 1-foot spacing or (1-meter spacing), the title of the column changes to the parameter name explained below.

Reactance X_a at 1-meter spacing (1-foot spacing)

This parameter is accessible only when **Conductor internal inductance specified from** is set to Reactance X_a at 1-meter spacing or (1-foot spacing). Specify the X_a value in ohms/km or ohms/mile at the specified frequency. The X_a value at 60 Hz or 50 Hz is usually provided by conductor manufacturers.

Conductor DC resistance

Specify the DC resistance of conductor in ohms/km or ohms/mile.

Conductor relative permeability

Specify the relative permeability μ_r of the conducting material. $\mu_r = 1.0$ for nonmagnetic conductors (aluminum, copper). This parameter is not accessible when the **Include conductor skin effect** parameter is not checked.

Number of conductors per bundle

Specify the number of subconductors in the bundle or 1 for single conductors.

Bundle diameter

Specify the bundle diameter in centimeters or inches. This parameter is not accessible when the **Number of conductors per bundle** is set to 1. When you specify bundled conductors, the subconductors are assumed to be evenly spaced on a circle. If this is not the case, you must enter individual subconductor positions in the **Line Geometry** table and lump these subconductors together by giving them the same **Phase number** parameter.

Angle of conductor 1

Specify an angle in degrees that determines the position of the first conductor in the bundle with respect to a horizontal line parallel to ground. This angle determines the bundle orientation. This parameter is not accessible when the **Number of conductors per bundle** is set to 1.

Line Geometry **Number of phase conductors (bundles)**

Specify the number of phase conductors (single conductors or bundles of subconductors) to be used. This parameter, together with the **Number of ground wires (bundles)** parameter, determines the number of rows of the table of conductors.

Number of ground wires (bundles)

Specify the number of ground wires (single conductors or bundles of subconductors) to be used. Ground wires are usually not bundled. This parameter, together with the **Number of phase conductors (bundles)** parameter, determines the number of rows of the table of conductors.

In the table of conductors, five rows are visible at a time. If more than five conductors (phase conductors plus ground wires) are specified, a scroll bar appears at the right side of the table to give you access to the different rows of the table.

Conductor (bundle)

Lists the conductor or bundle identifiers. Phase conductors are identified p1, p2,..., pn. Ground wires are identified g1,g2,..., gn.

Phase number

Specify the phase number to which the conductor belongs. Several conductors may have the same phase number. All conductors having the same phase number are lumped together and will be considered as a single equivalent conductor in the R L C matrices. For example, if you want to compute the line parameters of a three-phase line equivalent to a double-circuit line such as the one represented in the figure named “Configuration of a Three-Phase Double-Circuit Line” on page 8-13, you specify phase numbers 1, 2, 3 for conductors p1, p2, p3 (circuit 1) and phase numbers 3, 2, 1 for conductors p4, p5, p6 (circuit 2), respectively. If you prefer to simulate this line as two individual circuits and have access to the six phase conductors, you would rather specify phase numbers 1, 2, 3, 6, 5, 4 respectively for conductors p1, p2, p3, p4, p5 and p6.

In three-phase systems, the three phases are usually labeled A, B, C. The correspondence with the phase number is

$$1, 2, 3, \quad 4, 5, 6, \quad 7, 8, 9, \dots = \quad A, B, C, \quad A, B, C \quad A, B, C, \dots$$

You can also use the phase number to lump conductors of an asymmetrical bundle.

For ground wires, the phase number is forced to zero. All ground wires are lumped with the ground and they do not contribute to the R L C matrix dimensions. If you need to access the ground wire connections in your model, you must specify these ground wires as normal phase conductors and connect them to the ground by yourself.

X

Specify the horizontal position of the conductor in meters or feet. The location of the zero reference position is arbitrary. For a symmetrical line you normally choose $X = 0$ at the center of the line.

Y tower

Specify the vertical position of the conductor (at the tower) with respect to ground, in meters or feet.

Y min

Specify the vertical position of the conductor with respect to ground at mid span, in meters or feet.

The average height of the conductor (see the figure named “Configuration of a Three-Phase Double-Circuit Line” on page 8-13) is given by

$$Y_{average} = Y_{min} + \frac{sag}{3} = \frac{2Y_{min} + Y_{tower}}{3}$$

where: Y_{tower} = height of conductor at tower
 Y_{min} = height of conductor at mid span
 $sag = Y_{tower} - Y_{min}$

Instead of specifying two different values for Y_{tower} and Y_{min} , you may specify the same $Y_{average}$ value.

Conductor (bundle) type

Specify one of the conductor or bundle type numbers listed in the first column of the table of conductor characteristics.

Compute RLC parameters

Computes the RLC parameters. After completion of the parameters computation, results are displayed in a new window entitled **Display RLC Values**.

Display RLC Values

The frequency and ground resistivity used for evaluation of the RLC matrices are first displayed. Then come the computed RLC parameters.

Note The R, L, C parameters are always displayed respectively in ohms/km, henries/km, and farads/km, even if the english units have been used to specify the input parameters.

If the number of phase conductors is 3 or 6, the symmetrical component parameters are also displayed:

- For a three-phase line (one circuit), R10, L10, and C10 vectors of two values are displayed for positive-sequence and zero-sequence RLC values.
- For a six-phase line (two coupled three-phase circuits), R10, L10 and C10 vectors of five values containing the following RLC sequence parameters: positive-sequence and zero-sequence of circuit 1, mutual zero-sequence between circuit 1 and circuit 2, positive-sequence and zero-sequence of circuit 2.

The **Display RLC Values** window also allows you to download parameters into your workspace and/or into your transmission line models.

Send RLC parameters to workspace

Sends the three RLC matrices as well as the symmetrical component parameters in the MATLAB workspace. The following variables are created in your workspace: R_matrix, L_matrix, C_matrix, and R10, L10, C10 for symmetrical components.

Send RLC parameters to block

Sends the RLC parameters into one of the following three blocks that you have previously selected in your model: the Distributed Parameter Line block (either matrices or sequence RLC parameters), the single-phase PI

power_lineparam

Section Line block (one dimension matrix required) or the Three-Phase PI Section Line block (sequence components only).

Selected block

Clicking this button confirms the block selection. The name of the selected block appears in the left window.

RLC matrices sequences

Downloads either RLC matrices or RLC sequence parameters into the selected block.

Create a report

Creates a file `XXX.rep` containing the line input parameters and the computed RLC parameters. The MATLAB editor opens to display the contents of the `XXX.rep` file.

Close

Closes the **Display RLC Values** window.

Save/Load

You can save and reload your line data. You can also load typical line data provided with SimPowerSystems.

Save

Saves your line data by generating a `.mat` file that contains the GUI information and the line data.

Load

Opens a window where you have to select either **Typical line data** (examples of line configurations provided with SimPowerSystems) or **User defined line data** (your own line data). A browser then opens for selecting the desired `.mat` file.

Typical Line Data

In the **Load** menu, selecting **Typical line data** allows you to load one of the following line configurations:

Line_25kV_4wires.mat	25-k V, three-phase distribution feeder with accessible neutral conductor.
Line_315kV_2circ.mat	315-k V, three-phase, double-circuit line using bundles of two conductors. Phase numbering is set

	to obtain the RLC parameters of the two individual circuits (six-phase line).
Line_450kV.mat	Bipolar +/-450-k V DC line using bundles of four conductors.
Line_500kV_2circ.mat	500-k V, three-phase, double-circuit line using bundles of three conductors. Phase numbering is set to obtain the RLC parameters of the three-phase line circuit equivalent to the two circuits connected in parallel.
Line_735kV.mat	735-k, V three-phase, line using bundles of four conductors.

Examples

The following two examples illustrate the inputs and outputs of the power_lineparam GUI.

Example 1

The first case is an academic example. It uses a simple line consisting of two conductors spaced by 1 meter at an average height of 8 meters above a perfect ground (ground resistivity $\rho_g = 0$). The two conductors are solid aluminum conductors (resistivity $\rho_c = 28.3 \cdot 10^{-9} \Omega \cdot \text{m}$ at 20°C) having a 15-mm diameter.

The DC resistance per km of each conductors is

$$r = \frac{\rho_c \cdot l}{A} = \frac{28.3 \times 10^{-9} \times 1000}{\pi \cdot \left(\frac{15 \times 10^{-3}}{2}\right)^2} = 0.1601 \Omega/\text{km}$$

As ground is supposed to be perfect, the off diagonal terms of the R matrix are zero and the diagonal terms represent the conductor resistances:

$$R = \begin{bmatrix} 0.1601 & 0 \\ 0 & 0.1601 \end{bmatrix} \Omega/\text{km}$$

For the solid conductors, the GMR is

$$GMR = r \cdot e^{-\mu_r/4} = \frac{1.5}{2} e^{-1/4} = 0.5841 \text{ cm}$$

The self and mutual inductances are computed as follows. The ΔL correction terms are ignored because ground resistivity is zero.

$$L_{11} = L_{22} = \frac{\mu_0}{2\pi} \cdot \log \frac{2h_i}{GMR} = 2 \times 10^{-4} \log \frac{2 \times 8}{0.5841 \times 10^{-2}} = 1.583 \times 10^{-3} \text{ H/km}$$

$$L_{12} = L_{21} = \frac{\mu_0}{2\pi} \cdot \log \frac{D_{12}}{d_{12}} = 2 \times 10^{-4} \log \frac{\sqrt{16^2 + 1}}{1} = 0.5549 \times 10^{-3} \text{ H/km}$$

$$L = \begin{bmatrix} L_{11} & L_{12} \\ L_{21} & L_{22} \end{bmatrix} = \begin{bmatrix} 1.583 \times 10^{-3} & 0.5549 \times 10^{-3} \\ 0.5549 \times 10^{-3} & 1.583 \times 10^{-3} \end{bmatrix} \text{ H/km}$$

The self and mutual capacitances are computed as follows:

$$P_{11} = P_{22} = \frac{1}{2\pi\epsilon_o} \log \frac{2h}{r_i} = 1.7975 \times 10^7 \log \frac{2 \times 8}{0.75 \times 10^{-2}} = 1.3779 \times 10^8 \text{ km/F}$$

$$P_{12} = P_{21} = \frac{1}{2\pi\epsilon_o} \log \frac{D_{12}}{d_{12}} = 1.7975 \times 10^7 \log \frac{\sqrt{16^2 + 1}}{1} = 4.9872 \times 10^7 \text{ km/F}$$

$$C = \begin{bmatrix} P_{11} & P_{12} \\ P_{21} & P_{22} \end{bmatrix}^{-1} = \begin{bmatrix} 8.352 \times 10^{-9} & -3.023 \times 10^{-9} \\ -3.023 \times 10^{-9} & 8.352 \times 10^{-9} \end{bmatrix} \text{ F/km}$$

Enter the line parameters in the power_lineparam GUI as shown below. Make sure that the specified frequency is 50 Hz and select T/D ratio for computing the line inductance. Do not check **Include conductor skin effect**.

Power_lineparam. Line Data of example1_doc.mat

Units:

Frequency (Hz):

Ground resistivity (ohm.m):

Comments:
Example 1
Two 15mm diameter, solid copper wires spaced by 1 meter, at 8 meters above a perfectly conducting ground.

Line Geometry

Number of phase conductors (bundles):

Number of ground wires (bundles):

Conductor (bundle)	Phase number	X (m)	Y tower (m)	Y min (m)	Conductor (bundle) type
p 1	1	0	8	8	1
p 2	2	1	8	8	1
-	-	-	-	-	-
-	-	-	-	-	-
-	-	-	-	-	-

Conductor and Bundle Characteristics

Number of conductor types or bundle types:

Conductor internal inductance evaluated from:

Include conductor skin effect

Conductor (bundle) type	Conductor outside diameter (cm)	Conductor T/D ratio	Conductor GMR (cm)	Conductor DC resistance (Ohm/km)	Conductor relative permeability	Number of conductors per bundle	Bundle diameter (cm)	Angle of conductor 1 (degrees)
1	1.5	0.5	0.584335	0.1601	1	1	0	0
-	-	-	-	-	-	-	-	-

Notice that the displayed GMR value (0.58433 cm) is the GMR value that should be used to include the change of conductor inductance due to frequency. This GMR value is slightly higher than the theoretical DC value (0.5841 cm). This 0.04% increase is due to skin effect at 50 Hz which produces a non uniform current distribution. In our case, the line parameters will be evaluated in DC because we are not including the skin effect.

power_lineparam

Click **Compute RLC Parameters**. A new window **Display RLC Values** opens. Compare the RLC matrices with their theoretical values.

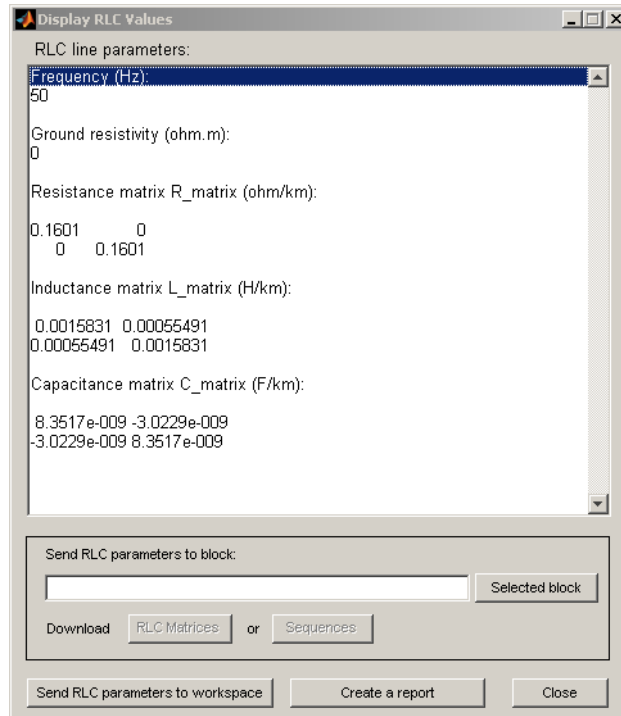

The PI model for a 1-km line is obtained from the RLC matrices. The PI RLC values are deduced from the self and mutual terms of the RLC matrices, as explained below. Subscript s and m designate the self and mutual terms in the RLC matrices.

$$R_{p1}=R_{p2} = R_s = 0.1601 \Omega/\text{km}; \quad L_{p1}=L_{p2} = L_s = 1.583 \text{ mH}/\text{km}$$

$$C_{p1}= C_{p2}= C_s + C_m= 8.352 - 3.023 = 5.329 \text{ nF}/\text{km}$$

(2.664 nF at each end of PI section)

$$C_{p1p2} = - C_m= 3.023 \text{ nF}/\text{km} \quad (1.511 \text{ nF at each end of PI section})$$

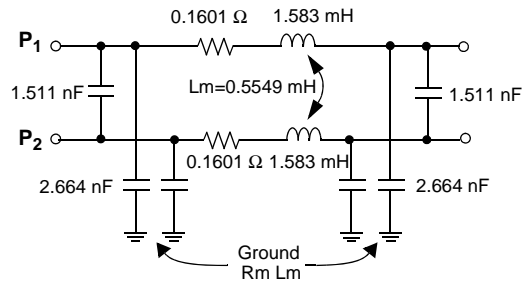
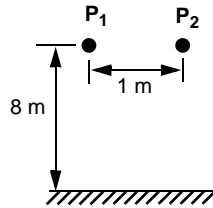

You can also vary the ground resistivity and the frequency and observe their impact on the resistance and inductance of the conductor and of the ground return.

Vary the ground resistivity from zero to 10000 $\Omega \cdot \text{m}$ while keeping the frequency constant at 50 Hz. You should get values listed in the table below. The expressions R_s - R_m and L_s - L_m represent respectively the resistance and the inductance of the conductor, whereas R_m and L_m are the resistance and the inductance of the ground return.

Impact of Ground Resistivity (Frequency = 50 Hz; Skin Effect Not Included)

Ground Resistivity (W.m)	Conductor R_s - R_m (W/km)	Ground R_m (W/km)	Conductor L_s - L_m (mH/km)	Ground L_m (mH/km)
0	0.1601	0	1.028	0.5549
10	0.1601	0.04666	1.029	1.147
100	0.1601	0.04845	1.029	1.370
10 000	0.1601	0.04925	1.029	1.828

When the ground resistivity varies in a normal range (between 10 $\Omega\cdot\text{m}$ for a humid soil and 10 000 $\Omega\cdot\text{m}$ for a dry rocky ground), the ground resistance remains almost constant at 0.05 Ω/km , whereas its inductance increases from 1.15 mH/km to 1.83 mH/km.

Now select **Include conductor skin effect** and repeat computation with different frequencies ranging from 0.05 Hz to 50 kHz, while keeping a ground resistivity of 100 $\Omega\cdot\text{m}$.

Impact of Frequency (Ground Resistivity = 100 $\Omega\cdot\text{m}$; with Conductor Skin Effect)

Frequency (Hz)	Conductor Rs-Rm (W/km)	Ground Rm (W/km)	ConductorLs -Lm (mH/km)	Ground Lm (mH/km)
0.05	0.1601	4.93e-5	1.029	2.058
50	0.1606	0.04844	1.029	1.370
500	0.2012	0.4666	1.022	1.147
5000	0.5442	4.198	0.9944	0.9351
50 000	1.641	32.14	0.9836	0.7559

This table shows that frequency has a very large impact on ground resistance and much lower influence on ground inductance. Because of skin effect in the ground, when frequency increases, the ground current flows closer to the surface, reducing the equivalent section of the ground conductor and thus increasing its resistance. As ground current travels at a lower depth at high frequencies, this also means that the loop inductance of conductor plus ground return (or self inductance L_s) decreases.

Because of conductor skin effect, frequency has a noticeable impact on conductor resistance from a few hundreds of hertz but a negligible impact on conductor inductance. At nominal system frequency (50 Hz or 60 Hz), the increase of conductor resistance with respect to DC resistance (0.1601 Ω/km) is only 0.3%.

Example 2

This example corresponds to a 500-kV, three-phase, double-circuit line. Using the **Load** button, load the `Line_500kV_2circ.mat` line configuration saved in the typical line data. The `power_lineparam` GUI is shown below:

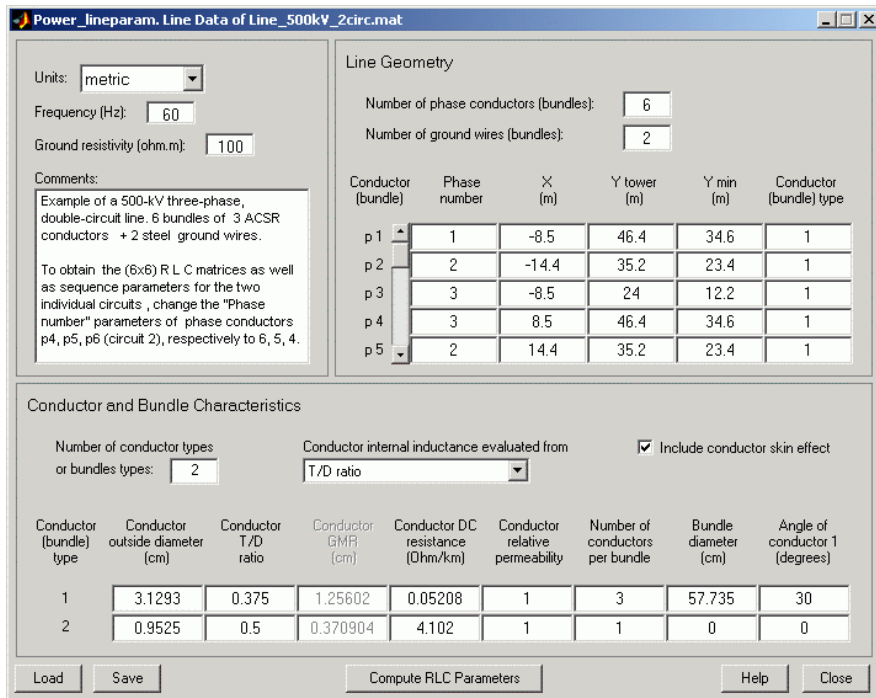

Power is transmitted over six phase conductors forming the two three-phase circuits. The line is protected against lightning by two ground wires. The phase conductors use bundles of three subconductors. Subconductors are located at the top of an equilateral triangle of 50 cm side, corresponding to a 57.735 cm bundle diameter. This line configuration corresponds to the one shown in the figure named “Configuration of a Three-Phase Double-Circuit Line” on page 8-13.

Phase numbering has been set to obtain the line parameters of the three-phase line equivalent to the two circuits connected in parallel. Click **Compute RLC Parameters** to display the RLC matrices and sequence parameters.

power_lineparam

The positive-sequence and zero-sequence parameters of the transposed line are displayed in the **Display Results** window in the R10 and L10 vectors:

$$R1 = 0.009009 \Omega/\text{km} \quad R0 = 0.2556 \Omega/\text{km}$$

$$L1 = 0.4408 \text{ mH}/\text{km} \quad L0 = 2.601 \text{ mH}/\text{km}$$

$$C1 = 25.87 \text{ nF}/\text{km} \quad C0 = 11.62 \text{ nF}/\text{km}$$

You can also get the parameters of the two individual circuits and have access to the six phase conductors. Change the phase numbers of conductors p4, p5, and p6 (circuit 2) to 6, 5, 4, respectively. The positive-sequence, zero-sequence and mutual zero-sequence parameters of the transposed line are listed below:

$$R1 = 0.01840 \Omega/\text{km} \quad R0 = 0.2649 \Omega/\text{km} \quad R0m = 0.2462 \Omega/\text{km}$$

$$L1 = 0.9296 \text{ mH}/\text{km} \quad L0 = 3.202 \text{ mH}/\text{km} \quad L0m = 2.0 \text{ mH}/\text{km}$$

$$C1 = 12.57 \text{ nF}/\text{km} \quad C0 = 7.856 \text{ nF}/\text{km} \quad C0m = -2.044 \text{ nF}/\text{km}$$

As the line is symmetrical, the positive- and zero-sequence parameters for circuit 2 are identical to the parameters of circuit 1.

References

[1] Dommel, H., et al., *Electromagnetic Transients Program Reference Manual* (EMTP Theory Book), 1986.

[2] Carson, J. R., "Wave Propagation in Overhead Wires with Ground Return," *Bell Systems Technical Journal*, Vol. 5, pp 539-554, 1926.

See Also

Powergui, Distributed Parameter Line, PI Section Line, Three-Phase PI Section Line

Purpose	Compute state-space model of linear electrical circuit
Synopsis	<p>You must call <code>power_statespace</code> with a minimum of seven input arguments.</p> <pre>[A,B,C,D,states,x0,x0sw,r1sw,u,x,y,freq,Asw,Bsw,Csw,Dsw,Hlin] = power_statespace(rlc,switches,source,line_dist,yout,y_type,unit)</pre> <p>You can also specify optional arguments. To use these optional arguments, the number of input arguments must be 12, 13, 14 or 16.</p> <pre>[A,B,C,D,states,x0,x0sw,r1sw,u,x,y,freq,Asw,Bsw,Csw,Dsw,Hlin] = power_statespace(rlc,switches,source,line_dist,yout,y_type,unit, net_arg1,net_arg2,net_arg3,...,netsim_flag,fid_outfile, freq_sys,ref_node,vary_name,vary_val)</pre>
Description	<p>The <code>power_statespace</code> command computes the state-space model of a linear electrical circuit expressed as</p> $\dot{x} = Ax + Bu$ $y = Cx + Du$ <p>where x is the vector of state-space variables (inductor currents and capacitor voltages), u is the vector of voltage and current inputs, and y is the vector of voltage and current outputs.</p> <p>When you build a circuit from SimPowerSystems blocks of the powerlib library, <code>power_statespace</code> is automatically called by the <code>power_analyze</code> command. <code>power_statespace</code> is also available as a stand-alone command for expert users. This allows you to generate state-space models without using the SimPowerSystems block modeling interface and to access options that are not available through powerlib. For example, using <code>power_statespace</code>, you can model transformers and mutual inductances with more than three windings.</p> <p>The linear circuit can contain any combination of voltage and current sources, RLC branches, multiwinding transformers, mutually coupled inductances, and switches. The state variables are inductor currents and capacitor voltages.</p> <p>The state-space representation (matrices A,B,C,D, and vector x0) computed by <code>power_statespace</code> can then be used in a Simulink system, via a State-Space block, to perform simulation of the electrical circuit (see “Example” on page 8-44). Nonlinear elements (mechanical or power electronic switches,</p>

transformer saturation, machines, distributed parameter lines, etc.) can be connected to the linear circuit.

These Simulink models are interfaced with the linear circuit through voltage outputs and current inputs of the state-space model. You can find the models of the nonlinear elements provided with SimPowerSystems in the **powerlib_models** library (see Chapter 3, “Improving Simulation Performance”).

Input Arguments

The number of input arguments must be 7, 12, 13, 14, or 16. Arguments 8 to 16 are optional. The first seven arguments that must be specified are

- **r1c**: Branch matrix specifying the network topology as well as the resistance R, inductance L, and capacitance C values. See format below.
- **switches**: Switch matrix. Specify an empty variable if no switches are used. See format below.
- **source**: Source matrix specifying the parameters of the electrical voltage and current sources. Specify an empty variable if no sources are used. See format below.
- **line_dist**: Distributed parameter line matrix. Specify an empty variable if no distributed lines are used. See format below.
- **yout**: String matrix of output expressions. See format below.
- **y_type**: Integer vector indicating output types (0 for voltage output, 1 for current output).
- **unit**: String specifying the units to be used for R, L, and C values in the **r1c** matrix. If **unit** = 'OHM', R L C values are specified in ohms Ω at the fundamental frequency specified by **freq_sys** (default value is 60 Hz). If **unit** = 'OMU', R L C values are specified in ohms (Ω), millihenries (mH), and microfarads (μF).

The last nine arguments are optional. The first three are used to pass arguments from the **power_analyze** command. Hereafter, only the arguments to be specified when **power_statespace** is used as a stand-alone command are described:

- **net_arg1**, **net_arg2**, **net_arg3**: Used to pass arguments from **power_analyze**. Specify an empty variable [] for each of these arguments.

- `netsim_flag`: Integer controlling the messages displayed during the execution of `power_statespace`. Default value is 0.
If `netsim_flag = 0`, the version number, number of states, inputs, outputs, and modes are displayed. Output values are displayed in polar form for each source frequency.
If `netsim_flag = 1`, only version number, number of states, inputs, and outputs are displayed.
If `netsim_flag = 2`, no message is displayed during execution.
- `fid_outfile`: File identifier of the `power_statespace` output file containing parameter values, node numbers, steady-state outputs, and special messages. Default value is 0.
- `freq_sys`: Fundamental frequency (Hz) considered for specification of X_L and X_C reactances if unit is set to 'OHM'. Default value is 60 Hz.
- `ref_node`: Reference node number used for ground of PI transmission lines. If -1 is specified, the user is prompted to specify a node number.
- `vary_name`: String matrix containing the symbolic variable names used in output expressions. These variables must be defined in your MATLAB workspace.
- `vary_val`: Vector containing the values of the variable names specified in `vary_name`.

Output Arguments

- `A, B, C, D`: state-space matrices of the linear circuit with all switches open.
`A(nstates, nstates)` , `B(nstates, ninput)` ,
`C(noutput, nstates)` , `D(noutput, ninput)` ,

where `nstates` is the number of state variables, `ninput` is the number of inputs, and `noutput` is the number of outputs.

- `states`: String matrix containing the names of the state variables. Each string has the following format:

Inductor currents: `I1_bxx_nzz1_zz2`

Capacitor voltages: `Uc_bxx_nzz1_zz2`

where

`xx` = branch number

`zz1` = first node number of the branch

`zz2` = second node number of the branch

The last lines of the states matrix, which are followed by an asterisk, indicate inductor currents and capacitor voltages that are not considered as state variables. This situation arises when inductor currents or capacitor voltages are not independent (inductors forming a cut set – for example, inductors connected in series – or capacitors forming a loop). The currents and voltages followed by asterisks can be expressed as a linear combination of the other state variables:

- x_0 : Column vector of initial values of state variables considering the open or closed status of switches.
- x_{0sw} : Vector of initial values of switch currents.
- r_{1sw} : Matrix ($n_{switch}, 2$) containing the R and L values of series switch impedances in ohms (Ω) and henries (H). n_{switch} is the number of switches in the circuit.
- u, x, y : Matrices $u(n_{input}, n_{freq})$, $x(n_{states}, n_{freq})$, and $y(n_{output}, n_{freq})$ containing the steady-state complex values of inputs, states, and outputs. n_{freq} is the length of the $freq$ vector. Each column corresponds to a different source frequency, as specified by the next argument, $freq$.
- $freq$: Column vector containing the source frequencies ordered by increasing frequency.
- $A_{sw}, B_{sw}, C_{sw}, D_{sw}$: State-space matrices of the circuit including the closed switches. Each closed switch with an internal inductance adds one extra state to the circuit.
- H_{lin} : Three-dimensional array ($n_{freq}, n_{output}, n_{input}$) of the n_{freq} complex transfer impedance matrices of the linear system corresponding to each frequency of the $freq$ vector.

Format of the RLC Input Matrix

Two formats are allowed:

- Six columns: Implicit branch numbering. Branch numbers correspond to the RLC line numbers.
- Seven columns: Explicit branch numbering. Branch number N_{obr} is assigned by the user.

Each line of the RLC matrix must be specified according to the following format.

[node1, node2, type, R, L, C, Nobr] for RLC branch or line branch

[node1, node2, type, R, L, C, Nobr] for transformer magnetizing branch

[node1, node2, type, R, L, U, Nobr] for transformer winding

[node1, node2, type, R, L, U, Nobr] for mutual inductances

- node1: First node number of the branch. The node number must be positive or zero. Decimal node numbers are allowed.
- node2: Second node number of the branch. The node number must be positive or zero. Decimal node numbers are allowed.
- type: Integer indicating the type of connection of RLC elements, or, if negative, the transmission line length:

type = 0: Series RLC element

type = 1: Parallel RLC element

type = 2: Transformer winding

type = 3: Coupled (mutual) winding

If type is negative, the transmission line is modeled by a PI section of length $|\text{type}|$. See details below.

For a mutual inductor or a transformer having N windings, $N+1$ consecutive lines must be specified in RLC matrix:

- 1 N lines with type = 2 or type = 3; (one line per winding). Each line specifies $R/L/U$ or $R/Xl/Xc$ where $[R/L, R/Xl =$ winding resistance and leakage reactance for a transformers or winding resistance and self reactance for mutually coupled windings. U is the nominal voltage of transformer winding (specify 0 if type = 3).
- 2 One extra line with type = 1 for the magnetizing branch of a transformer (parallel Rm/Lm or Rm/Xm) or one line with type = 0 for a mutual impedance (series Rm/Lm or Rm/Xm).

For a transformer magnetizing branch or a mutual impedance, the first node number is an internal node located behind the leakage reactance of the first winding. The second node number must be the same as the second node number of the first winding.

To model a saturable transformer, you must use a nonlinear inductance instead of the linear inductance simulating the reactive losses. Set the Lm/Xm value to 0 (no linear inductance) and use the Saturable Transformer block, set with proper flux-current characteristics.

This block can be found in the **powerlib_models/Continuous** library. It must be connected to the linear part of the system (State-Space block or S-function) between a voltage output (voltage across the magnetizing branch) and a current input (current source injected into the transformer internal node). See the “Example” on page 8-44.

If `type` is negative, its absolute value specifies the length (km) of a transmission line simulated by a PI section. For a transmission line, the R/L/C or R/Xl/Xc values must be specified in Ω/km , mH/km, and $\mu\text{F}/\text{km}$, or in Ω/km .

Parameter	Description
R	Branch resistance (Ω)
X1	Branch inductive reactance (Ω at <code>freq_sys</code>) or transformer winding leakage reactance (Ω at <code>freq_sys</code>)
L	Branch inductance (mH)
Xc	Branch capacitive reactance (Ω at <code>freq_sys</code>). The negative sign of Xc is optional.
C	Capacitance (μF)
U	Nominal voltage of transformer winding. The same units (volts or kV) must be used for each winding. For a mutual inductance (<code>type=3</code>), this value must be set to zero.

Zero value for R, L or X1, C or Xc in a series or parallel branch indicates that the corresponding element does not exist.

The following restrictions apply for transformer winding R-L values. Null values are not allowed for secondary impedances if some transformer secondaries form loops (as in a three-phase delta connection). Specify a very low value for R or L or both (e.g., $1e-6$ p.u. based on rated voltage and power) to simulate a quasi-ideal transformer. The resistive and inductive parts of the magnetizing branch can be set to infinite (no losses; specify $X_m = R_m = \text{inf}$).

Format of the Source Input Matrix

Three formats are allowed:

- Five columns: All sources are generating the same frequency specified by `freq_sys`.
- Six columns: The frequency of each source is specified in column 6.
- Seven columns: The seventh column is used to specify the type of nonlinear element modeled by the current source.

Each line of the source matrix must be specified according to the following format:

```
[ node1, node2, type, amp, phase, freq, model ]
```

- `node1, node2`: Node numbers corresponding to the source terminals. These are the polarity conventions:
 - Voltage source: `node1` is the positive terminal.
 - Current source: Positive current flowing from `node1` to `node2` inside the source.
- `type`: Integer indicating the type of source: 0 for voltage source, 1 for current source.
- `amp`: Amplitude of the AC or DC voltage or current (V or A).
- `phase`: Phase of the AC voltage or current (degree).
- `freq`: Frequency (Hz) of the generated voltage or current. Default value is 60 Hz. For a DC voltage or current source, specify `phase = 0` and `freq = 0`. `amp` can be set to a negative value. The generated signals are $\text{amp} * \sin(2\pi * \text{freq} * t + \text{phase})$ for AC, `amp` for DC.
- `model`: Integer specifying the type of nonlinear element modeled by the current source (saturable inductance, thyristor, switch,...). Used by `power_analyze` only.

Order in Which Sources Must Be Specified

The commands that compute the state-space representation of a system expect the sources in a certain order. You must respect this order in order to obtain correct results. You must be particularly careful if the system contains any switches. This is the proper ordering of sources:

- 1 The currents from all switches that have a null inductance (`Lon = 0`), if any.

- 2 The currents from all nonlinear models that have a finite inductance (switches with $L_{on} > 0$, the magnetizing inductance in saturable transformers, etc.), if any.
- 3 All other voltage and current sources in any order, if any.

Refer to the Example section below for an example illustrating proper ordering of sources for a system containing nonlinear elements.

Format of the Switches Input Matrix

Switches are nonlinear elements simulating mechanical or electronic devices such as circuit breakers, diodes, or thyristors. Like other nonlinear elements, they are simulated by current sources driven by the voltage appearing across their terminals. Therefore, they cannot have a null impedance. They are simulated as ideal switches in series with a series R-L circuit. Various models of switches (circuit breaker, ideal switch, and power electronic devices) are available in the **powerlib_models** library. They must be interconnected to the linear part of the system through appropriate voltage outputs and current inputs.

The switch parameters must be specified in a line of the switches matrix in seven different columns, according to the following format.

```
[ node1, node2, status, R, L/X1, no_I , no_U ]
```

Parameter	Description
node1, node2	Node numbers corresponding to the switch terminals
status	Code indicating the initial status of the switch at $t = 0$: 0 = open; 1 = closed
R	Resistance of the switch when closed (Ω)
L/X1	Inductance of the switch when closed (mH) or inductive reactance (Ω at freq_sys)

For these last two fields, you must use the same units as those specified for the RLC matrix. Either field can be set to 0, but not both.

The next two fields specify the current input number and the voltage output number to be used for interconnecting the switch model to the State-Space

block. The output number corresponding to the voltage across a particular switch must be the same as the input number corresponding to the current from the same switch (see Example section below):

- no_I: Current input number coming from the output of the switch model
- no_U: Voltage output number driving the input of the switch model

Format of the Line_Dist Matrix

The distributed parameter line model contains two parts:

- 1 A linear part containing current sources and resistances that are connected at the line sending and receiving buses together with the linear circuit.
- 2 A nonlinear part available in the Distributed Parameter Line block of the Elements library. This block performs the phase-to-mode transformations of voltage and currents and simulates the transmission delays for each mode. The distributed_param_line block must be connected to appropriate voltage outputs and current inputs of the linear part of the system. The line parameters have to be specified in the line_dist matrix and also in the Distributed Parameter Line block.

Each row of the line_dist matrix is used to specify a distributed parameter transmission line. The number of columns of line_dist depends on the number of phases of the transmission line.

For an nphase line, the first $(4 + 3 * nphase + nphase^2)$ columns are used. For example, for a three-phase line, 22 columns are used.

[nphase, no_I, no_U, length, L/Xl, Zc, Rm, speed, Ti]

Parameter	Description
nphase	Number of phases of the transmission line
no_I	Input number in the source matrix corresponding to the first current source Is_1 of the line model. Each line model uses 2*nphase current sources specified in the source matrix as follows: Is_1, Is_2, ..., Is_nphase for the sending end followed by Ir_1, Ir_2, ..., Ir_nphase for the receiving end.

power_statespace

Parameter	Description (Continued)
nu_U	Output number of the state-space corresponding to the first voltage output Vs_1 feeding the line model. Each line model uses 2*nphase voltage outputs in the source matrix as follows: Vs_1, Vs_2,..., Vs_nphase for the sending end followed by Vr_1, Vr_2,..., Vr_nphase for the receiving end.
length	Length of the line (km)
Zc	Vector of the nphase modal characteristic impedances (Ω)
Rm	Vector of the nphase modal series resistances (Ω/km)
speed	Vector of the nphase modal propagation speeds (km/s)
Ti	Transformation matrix from mode to phase currents such that $I_{\text{phase}} = T_i * I_{\text{mod}}$. The nphase * nphase matrix must be given in vector format, [col_1, col_2, ... col_nphase].

Format of the Yout Matrix

The desired outputs are specified by a string matrix yout. Each line of the yout matrix must be an algebraic expression containing a linear combination of states and state derivatives, specified according to the following format.

Parameter	Description
Uc_bn	Capacitor voltage of branch n
I1_bn	Inductor current of branch n
dUc_bn	Derivative of Uc_bn or I1_bn
Un, In	Source voltage or current specified by line n of the source matrix
U_nx1_x2	Voltage between nodes x1 and x2 = $U_{x1} - U_{x2}$

Parameter	Description (Continued)
I_bn	Current in branch n flowing from node1 to node2 (See format of RLC matrix). For a parallel RLC branch, I_bn corresponds to the total current IR + IL + IC.
I_bn_nx	Current flowing into node x of a PI transmission line specified by line n of the RLC matrix. This current includes the series inductive branch current and the capacitive shunt current.

Each output expression is built from voltage and current variable names defined above, their derivatives, constants, other variable names, parentheses and operators (+ - * / ^), in order to form a valid MATLAB expression. For example

```
yout =
char(['R1*I_b1+Uc_b3-L2*dI1_b2', 'U_n10_20', 'I2+3*I_b5']);
```

If variable names are used (R1 and L2 in the above example), their names and values must be specified by the two input arguments vary_name and vary_val.

Sign Conventions for Voltages and Currents

Parameter	Sign Convention
I_bn, I1_bn, In	Branch current, inductor current of branch n , or current of source # n is oriented from node1 to node2
I_bn_nx	Current at one end (node x) of a PI transmission line. If x = node1, the current is entering the line. If x = node2, the current is leaving the line.
Uc_bn, Un	Voltage across capacitor or source voltage (Unode1 - Unode2)
U_nx1_x2	Voltage between nodes x1 and x2 = Ux1 - Ux2. Voltage of node x1 with respect to node x2.

Order in Which Outputs Must Be Specified

The commands that compute the state-space representation of a system expect the outputs to be in a certain order. You must respect this order in order to obtain correct results. You must be particularly careful if the system contains any switches. The following list gives the proper ordering of outputs:

- 1** The voltages across all switches that have a null inductance ($L_{on} = 0$), if any
- 2** The currents of all switches that have a null inductance ($L_{on} = 0$), if any, in the same order as the voltages above
- 3** The voltages across all nonlinear models that have a finite inductance (switches with $L_{on} > 0$, the magnetizing inductance in saturable transformers, etc.)
- 4** All other voltage and current measurements that you request, in any order

Refer to the Example section below for an example illustrating proper ordering of outputs for a system containing nonlinear elements.

Example

The following circuit consists of two sources (one voltage source and one current source), two series RLC branches (R1 - L1 and C6), two parallel RLC branches (R5 - C5 and L7 - C7), one saturable transformer, and two switches (Sw1 and Sw2). Sw1 is initially closed whereas Sw2 is initially open. Three measurement outputs are specified (I1, V2, and V3). This circuit has seven nodes numbered 0, 1, 2, 2.1, 10, 11, and 12. Node 0 is used for the ground. Node 2.1 is the internal node of the transformer where the magnetization branch is connected.

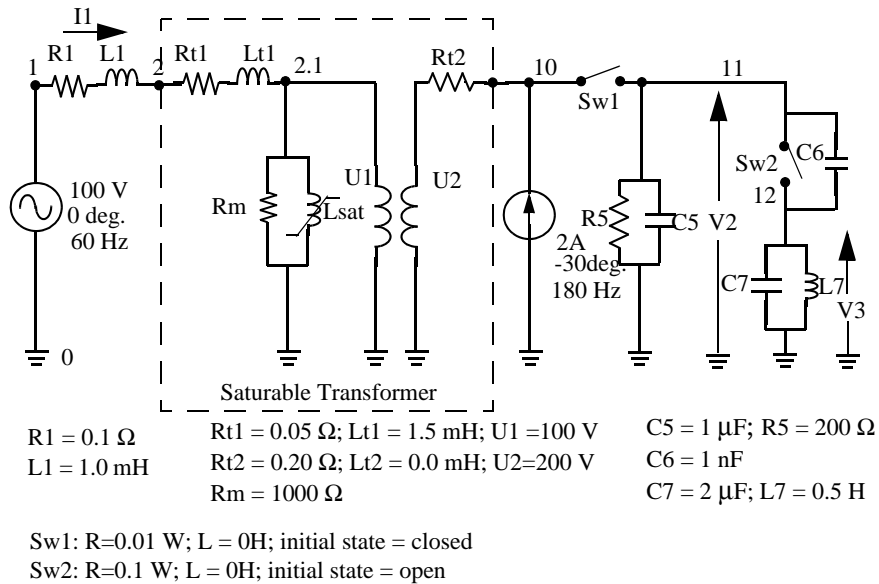

Linear state-space. You can use the `power_statespace` command to find the state-space model of the linear part of the circuit. The nonlinear elements Sw1, Sw2, and Lsat must be modeled separately by means of current sources driven by the voltages appearing across their terminals. Therefore you must provide three additional current sources and three additional voltage outputs for interfacing the nonlinear elements to the linear circuit.

You can find the state-space model of the circuit by entering the following commands in a MATLAB script file. The example is available in the `power_circ2ss.m` file. Notice that an output text file named `power_circ2ss.net` containing information on the system is requested in the call to `power_statespace`.

```

unit='OMU'; % Units = ohms, mH, and uF

rlc=[
%N1N2 typeR L C(uF)/U(V)
1 2 0 0.1 1 0 %R1 L1
2 0 2 0.051.5 100 %transfo Wind.#1
10 0 2 0.200 200 %transfo Wind.#2

```

power_statespace

```
2.10 1 10000 0 %transfo mag. branch
11 0 1 200 0 1 %R5 C5
11 12 0 0 0 1e-3%C6
12 0 1 0 500 2 %L7 C7
];

source=[
%N1N2 typeU/I phasefreq
10 11 1 0 0 0 %Sw1
11 12 1 0 0 0 %Sw2
2.10 1 0 0 0 %Saturation
1 0 0 100 0 60 %Voltage source
0 10 1 2 -30 180 %Current source
];

switches=[
%N1N2 statusR(ohm)L(mH)I#U# #
10 11 1 0.010 1 1 %Sw1
11 12 0 0.1 0 2 2 %Sw2
];

%outputs
%
% Both switches have Lon=0, so their voltages must be the first
outputs,
% immediately followed by their currents (in the same order as the
voltages).
% The voltage across all nonlinear models that don't have L=0
follow
% (in this case the saturable transformer's magnetizing inductor).
% The measurements that you request follow, in any order.
%
y_u1='U_n10_11';%U_Sw1= Voltage across Sw1
y_u2='U_n11_12';%U_Sw2= Voltage across Sw2
y_i3='I1'; %I1= Switch current Sw1
y_i4='I2'; %I2= Switch current Sw2
y_u5='U_n2.1_0';%U_sat= Voltage across saturable reactor
y_i6='I_b1';%I1 measurement
y_u7='U_n11_0';%V2 measurement
y_u8='U_n12_0';%V3 measurement
```



```
yout=char(y_u1,y_u2,y_i3,y_i4,y_u5,y_i6,y_u7,y_u8);% outputs
y_type=[0,0,1,1,0,1,0,0];%output types; 0=voltage 1=current

% Open file that contains power_statespace output information
fid=fopen('power_circ2ss.net','w');

[A,B,C,D,states,x0,x0sw,r1sw,u,x,y,freq,Asw,Bsw,Csw,Dsw,Hlin]=
power_statespace(rlc,switches,source,[],yout,y_type,unit,[],[],
[],0,fid);
```

Command line messages. While `power_statespace` is executing, the following messages are displayed.

```
Computing state space representation of linear electrical circuit
(V2.0)...
(4 states ; 5 inputs ; 7 outputs)
```

```
Oscillatory modes and damping factors:
F=159.115Hz zeta=4.80381e-08
```

```
Steady state outputs @ F=0 Hz :
y_u1= 0Volts
y_u2= 0Volts
y_i3= 0Amperes
y_i4= 0Amperes
y_u5= 0Volts
y_i6= 0Amperes
y_u7= 0Volts
y_u8= 0Volts
Steady state outputs @ F=60 Hz :
y_u1 = 0.009999 Volts < 3.168 deg.
y_u2 = 199.4 Volts < -1.148 deg.
y_i3 = 0.9999 Amperes < 3.168 deg.
y_i4 = 0 Amperes < 0 deg.
y_u5 = 99.81 Volts < -1.144 deg.
y_i6 = 2.099 Amperes < 2.963 deg.
y_u7 = 199.4 Volts < -1.148 deg.
y_u8 = 0.01652 Volts < 178.9 deg.
```

power_statespace

```
Steady state outputs @ F=180 Hz :
y_u1 = 0.00117 Volts < 65.23 deg.
y_u2 = 22.78 Volts < 52.47 deg.
y_i3 = 0.117 Amperes < 65.23 deg.
y_i4 = 0 Amperes < 0 deg.
y_u5 = 11.4 Volts < 53.48 deg.
y_i6 = 4.027 Amperes < 146.5 deg.
y_u7 = 22.83 Volts < 52.47 deg.
y_u8 = 0.0522 Volts < 52.47 deg.
```

State-space output. The names of the state variables are returned in the states string matrix.

```
states
states =
I1_b2_n2_2.1
Uc_b5_n11_0
Uc_b6_n11_12
I1_b7_n12_0
I1_b1_n1_2*
Uc_b7_n12_0*
```

Although this circuit contains a total of six inductors and capacitors, there are only four state variables. The names of the state variables are given by the first four lines of the states matrix. The last two lines are followed by an asterisk indicating that these two variables are a linear combination of the state variables. The dependencies can be viewed in the output file `power_circ2ss.net`.

```
The following capacitor voltages are dependent:
Uc_b7_n12_0 = + Uc_b5_n11_0 - Uc_b6_n11_12
The following inductor currents are dependent:
I1_b1_n1_2 = + I1_b2_n2_0
```

The A,B,C,D matrices contain the state-space model of the circuit without nonlinear elements (all switches open). The `x0` vector contains the initial state values considering the switch `Sw1` closed. The `Asw`, `Bsw`, `Csw`, and `Dsw` matrices contain the state-space model of the circuit considering the closed switch `Sw1`. The `x0sw` vector contains the initial current in the closed switch.

```
A
A =
-4.0006e+05    0    0    0
           0 -4995    0 -499.25
           0 -4992.5  04.9925e+05
           0     2    -2     0
```

```
Asw
Asw =
-80.999 -199.99    0    0
4.9947e+05 -5244.7    0 -499.25
4.9922e+05 -5242.1  04.9925e+05
           0     2    -2     0
```

The system source frequencies are returned in the freq vector.

```
freq
freq =
    0    60   180
```

The corresponding steady-state complex outputs are returned in the (6-by-3) y matrix where each column corresponds to a different source frequency.

For example, you can obtain the magnitude of the six voltage and current outputs at 60 Hz as follows.

```
abs(y(:,2))
ans =
    0.0099987
    199.42
    0.99987
    0
    99.808
    2.0993
    199.41
    0.016519
```

The initial values of the four state variables are returned in the x0 vector. You must use this vector in the State-Space block to start the simulation in steady state.

```
x0
x0 =
    2.3302
    14.111
    14.07
    3.1391e-05
```

The initial values of switch currents are returned in `x0sw`. To start the simulation in steady state, you must use these values as initial currents for the nonlinear model simulating the switches.

```
x0sw
x0sw =
    0.16155
    0
```

The Simulink diagram of the circuit shown in the following figure is available in the `power_circ2ss_slk` model. If no resistive switches had been used, the linear part of the circuit could have been simulated with the State-Space block of the Simulink/Continuous library. However, as resistive switches are used, the `sfun_psbcontc` S-function is used instead of the State-Space block. This S-function reevaluates the state-space matrices during simulation when the circuit topology is changing (after a switch is opened or closed). Appropriate inputs and outputs are used to connect the switch and saturable reactance models to the linear system. Notice that the status of each switch is fed back from the breaker to the S-function, after the inputs mentioned earlier. You can find the Breaker and Saturable Transformer blocks in the **powerlib_models/Continuous** library containing all the nonlinear continuous models used by SimPowerSystems. As the breaker model is vectorized, a single block is used to simulate the two switches Sw1 and Sw2.

If you use the **powerlib** library to build your circuit, the same Simulink system is generated automatically by the `power_analyze` command. The **powerlib** version of this system is also available in the `power_circ2ss_sps` model and is shown below.

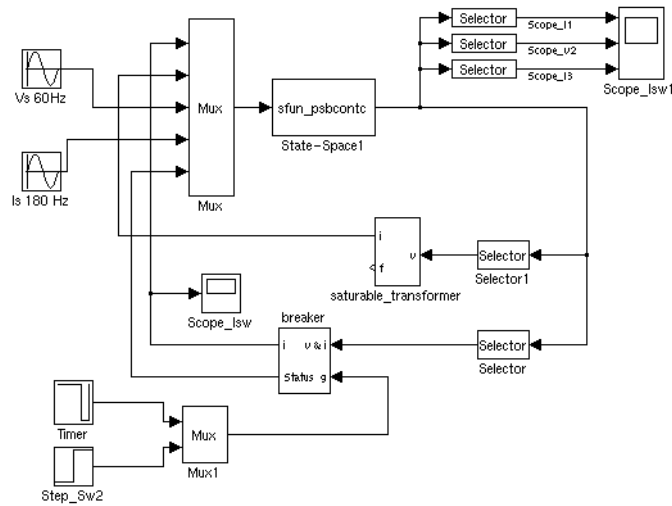

power_circ2ss_slk.mdl Example Diagram

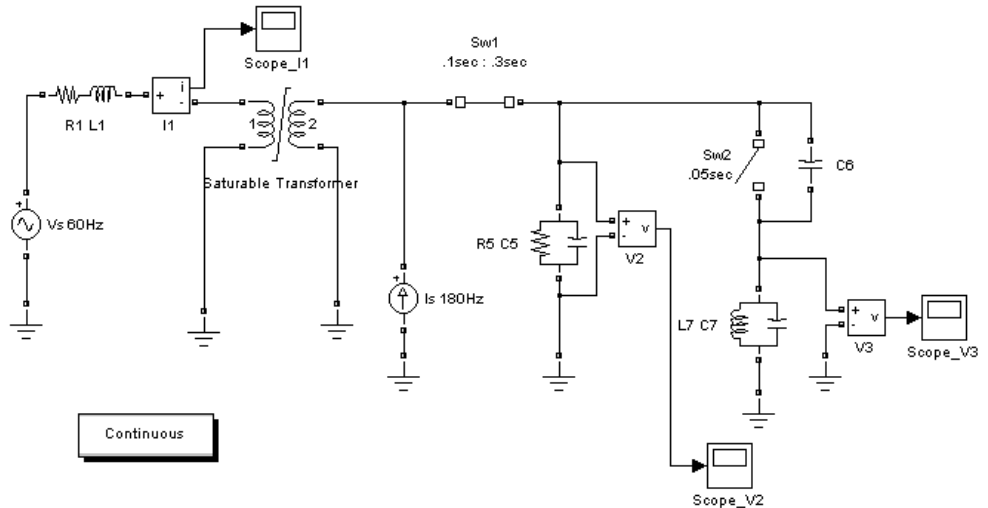

power_circ2ss_sps.mdl Example Diagram

See Also

power_analyze

power_statespace

Technical Conventions

This appendix describes the two units of measurement used in this manual.

- | | |
|--|--|
| International System of Units (p. A-2) | Explains the meter-kilogram-second (MKS) metric unit system (SI) |
| Per Unit (p. A-3) | Explains the per unit (p.u.) system, used occasionally to define power system model parameters |

International System of Units

This guide uses the International System of Units (SI), as described in the following table.

Quantity	Unit	Symbol
Time	second	s
Length	meter	m
Mass	kilogram	kg
Energy	joule	J
Current	ampere	A
Voltage	volt	V
Active power	watt	W
Apparent power	volt-ampere	VA
Reactive power	var	var
Impedance	ohm	Ω
Resistance	ohm	Ω
Inductance	henry	H
Capacitance	farad	F
Flux linkage	volt-second	V. s
Rotation speed	radians per second revolutions per minute	rad/s rpm
Torque	newton-meter	N.m
Inertia	kilogram-meter ²	kg.m ²
Friction factor	newton-meter-second	N.m.s

Per Unit

This guide also uses the per unit (p.u.) system to define the model parameters.

What Is the Per Unit System?

The per unit system is widely used in the power system industry to express values of voltages, currents, powers, and impedances of various power equipment. It is mainly used for transformers and AC machines.

For a given quantity (voltage, current, power, impedance, torque, etc.) the per unit value is the value related to a base quantity.

$$\text{base value in p.u.} = \frac{\text{quantity expressed in SI units}}{\text{base value}}$$

Generally the following two base values are chosen:

- The base power = nominal power of the equipment
- The base voltage = nominal voltage of the equipment

All other base quantities are derived from these two base quantities. Once the base power and the base voltage are chosen, the base current and the base impedance are determined by the natural laws of electrical circuits.

$$\text{base current} = \frac{\text{base power}}{\text{base voltage}}$$

$$\text{base impedance} = \frac{\text{base voltage}}{\text{base current}} = \frac{(\text{base voltage})^2}{\text{base power}}$$

For a transformer with multiple windings, each having a different nominal voltage, the same base power is used for all windings (nominal power of the transformer). However, according to the above definitions, there are as many base values as windings for voltages, currents, and impedances.

The saturation characteristic of saturable transformer is given in the form of an instantaneous current versus instantaneous flux-linkage curve: [i1 phi1; i2 phi2; ... , inphin].

When the Per Unit system is used to specify the transformer R L parameters, the flux linkage and current in the saturation characteristic must be also specified in p.u. The corresponding base values are

$$\text{base instantaneous current} = (\text{base rms current}) \times \sqrt{2}$$

$$\text{base flux linkage} = \frac{(\text{base rms voltage}) \times \sqrt{2}}{2\pi \times (\text{base frequency})}$$

where current, voltage, and flux linkage are expressed respectively in volts, amperes, and volt-seconds.

For AC machines, the torque and speed can be also expressed in p.u. The following base quantities are chosen:

- The base speed = synchronous speed
- The base torque = torque corresponding at base power and synchronous speed

$$\text{base torque} = \frac{\text{base power (3 phases) in VA}}{\text{base speed in radians/second}}$$

Instead of specifying the rotor inertia in $\text{kg}\cdot\text{m}^2$, you would generally give the inertia constant H defined as

$$H = \frac{\text{kinetic energy stored in the rotor at synchronous speed in joules}}{\text{machine nominal power in VA}}$$

$$H = \frac{\frac{1}{2} \times J \cdot \omega^2}{P_{nom}}$$

The inertia constant is expressed in seconds. For large machines, this constant is around 3 to 5 seconds. An inertia constant of 3 seconds means that the energy

stored in the rotating part could supply the nominal load during 3 seconds. For small machines, H is lower. For example, for a 3 HP motor, it can be between 0.5 and 0.7 second.

Example 1: Three-Phase Transformer

Consider, for example, a three-phase two-winding transformer. The following typical parameters could be provided by the manufacturer:

- Nominal power = 300 kVA total for three phases
- Nominal frequency = 60 Hz
- Winding 1: connected in wye, nominal voltage = 25 kV RMS line-to-line resistance 0.01 p.u., leakage reactance = 0.02 p.u.
- Winding 2: connected in delta, nominal voltage = 600 V RMS line-to-line resistance 0.01 p.u., leakage reactance = 0.02 p.u.
- Magnetizing losses at nominal voltage in % of nominal current:
Resistive 1%, Inductive 1%

The base values for each single-phase transformer are first calculated:

- For winding 1:

Base power	$300 \text{ kVA}/3 = 100\text{e}3 \text{ VA/phase}$
Base voltage	$25 \text{ kV}/\sqrt{3} = 14434 \text{ V RMS}$
Base current	$100\text{e}3/14434 = 6.928 \text{ A RMS}$
Base impedance	$14434/6.928 = 2083 \Omega$
Base resistance	$14434/6.928 = 2083 \Omega$
Base inductance	$2083/(2\pi*60) = 5.525 \text{ H}$

- For winding 2:

Base power	$300 \text{ kVA}/3 = 100\text{e}3 \text{ VA}$
Base voltage	600 V RMS
Base current	$100\text{e}3/600 = 166.7 \text{ A RMS}$
Base impedance	$600/166.7 = 3.60 \Omega$

Base resistance $600/166.7 = 3.60 \Omega$

Base inductance $3.60/(2\pi*60) = 0.009549 \text{ H}$

The values of the winding resistances and leakage inductances expressed in SI units are therefore

- For winding 1: $R_1 = 0.01 * 2083 = 20.83 \Omega$; $L_1 = 0.02*5.525 = 0.1105 \text{ H}$
- For winding 2: $R_2 = 0.01 * 3.60 = 0.0360 \Omega$; $L_2 = 0.02*0.009549 = 0.191 \text{ mH}$

For the magnetizing branch, magnetizing losses of 1% resistive and 1% inductive mean a magnetizing resistance R_m of 100 p.u. and a magnetizing inductance L_m of 100 p.u. Therefore, the values expressed in SI units referred to winding 1 are

- $R_m = 100*2083 = 208.3 \text{ k}\Omega$
- $L_m = 100*5.525 = 552.5 \text{ H}$

Example 2: Asynchronous Machine

Now consider the three-phase four-pole Asynchronous Machine block in SI units provided in the Machines library of **powerlib**. It is rated 3 HP, 220 V RMS line-to-line, 60 Hz.

The stator and rotor resistance and inductance referred to stator are

- $R_s = 0.435 \Omega$; $L_s = 2 \text{ mH}$
- $R_r = 0.816 \Omega$; $L_r = 2 \text{ mH}$

The mutual inductance is $L_m = 69.31 \text{ mH}$. The rotor inertia is $J = 0.089 \text{ kg}\cdot\text{m}^2$.

The base quantities for one phase are calculated as follows:

Base power $3 \text{ HP}*746\text{VA}/3 = 746 \text{ VA/phase}$

Base voltage $220 \text{ V}/\sqrt{3} = 127.0 \text{ V RMS}$

Base current $746/127.0 = 5.874 \text{ A RMS}$

Base impedance $127.0/5.874 = 21.62 \Omega$

Base resistance $127.0/5.874 = 21.62 \Omega$

Base inductance $21.62/(2\pi*60) = 0.05735 \text{ H} = 57.35 \text{ mH}$

Base speed 1800 rpm = $1800 \cdot (2\pi) / 60 = 188.5$ radians/second

Base torque (3-phase) $746 \cdot 3 / 188.5 = 11.87$ newton-meters

Using the above base values, you can compute the values in per units.

$R_s = 0.435 / 21.62 = 0.0201$ p.u. $L_s = 2 / 57.35 = 0.0349$ p.u.

$R_r = 0.816 / 21.62 = 0.0377$ p.u. $L_r = 2 / 57.35 = 0.0349$ p.u.

$L_m = 69.31 / 57.35 = 1.208$ p.u.

The inertia is calculated from inertia J , synchronous speed, and nominal power.

$$H = \frac{\frac{1}{2} \times J \cdot \omega^2}{P_{nom}} = \frac{\frac{1}{2} \times 0.089 \times (188.5)^2}{3 \times 746} = 0.7065 \text{ seconds}$$

If you open the dialog box of the Asynchronous Machine block in p.u. units provided in the Machines library of **powerlib**, you find that the parameters in p.u. are the ones calculated above.

Base Values for Instantaneous Voltage and Current Waveforms

When displaying instantaneous voltage and current waveforms on graphs or oscilloscopes, you normally consider the peak value of the nominal sinusoidal voltage as 1 p.u. In other words, the base values used for voltage and currents are the RMS values given above multiplied by $\sqrt{2}$.

Why Use the Per Unit System Instead of the Standard SI Units?

Here are the main reasons for using the per unit system:

- When values are expressed in p.u., the comparison of electrical quantities with their “normal” values is straightforward.

For example, a transient voltage reaching a maximum of 1.42 p.u. indicates immediately that this voltage exceeds the nominal value by 42%.

- The values of impedances expressed in p.u. stay fairly constant whatever the power and voltage ratings.

For example, for all transformers in the 3 kVA to 300 kVA power range, the leakage reactance varies approximately between 0.01 p.u. and 0.03 p.u., whereas the winding resistances vary between 0.01 p.u. and 0.005 p.u., whatever the nominal voltage. For transformers in the 300 kVA to 300 MVA range, the leakage reactance varies approximately between 0.03 p.u. and 0.12 p.u., whereas the winding resistances vary between 0.005 p.u. and 0.002 p.u.

Similarly, for salient pole synchronous machines, the synchronous reactance X_d is generally between 0.60 and 1.50 p.u., whereas the subtransient reactance X'_d is generally between 0.20 and 0.50 p.u.

It means that if you do not know the parameters for a 10 kVA transformer, you are not making a major error by assuming an average value of 0.02 p.u. for leakage reactances and 0.0075 p.u. for winding resistances.

The calculations using the per unit system are simplified. When all impedances in a multivoltage power system are expressed on a common power base and on the nominal voltages of the different subnetworks, the total impedance in p.u. seen at one bus is obtained by simply adding all impedances in p.u., without taking into consideration the transformer ratios.

A

- abc_to_dq0 Transformation block 7-12
- AC Current Source block 7-18
- AC motor drives 4-38
 - See also electric drive
- AC transmission network 6-2
- AC Voltage Source block 7-24
- AC1
 - block description 7-397
 - example 7-408
 - model specification 7-408
- AC1 parameters
 - asynchronous machine 7-401
 - converters and DC bus 7-402
- AC2
 - block description 7-410
 - block inputs and outputs 7-420
 - example 7-421
 - model specifications 7-421
- AC2 parameters
 - asynchronous machine 7-415
 - converters and DC bus 7-416
- AC3
 - block inputs and outputs 7-113
 - example 7-114
 - model specifications 7-114
- AC3 parameters
 - asynchronous machine 7-107
 - controller 7-111
 - converters and DC bus 7-108
- AC4
 - block description 7-85
 - example 7-96
 - models specifications 7-96
- AC4 parameters
 - asynchronous machine 7-89
 - controller 7-92

- converters and DC bus 7-90
- AC5
 - block description 7-347
 - block inputs and outputs 7-362
 - example 7-363
 - model specifications 7-363
- AC5 parameters
 - controller 7-357
 - converters and DC bus 7-354
 - synchronous machine 7-353
- AC6
 - block description 7-290
 - example 7-301
 - model specifications 7-301
- AC6 parameters
 - controller 7-299
 - converters and DC bus 7-296
 - PM synchronous machine 7-295
- Active & Reactive Power block 7-20
- adjustable speed drive (ASD) 4-4
- analysis
 - power_analyze command 8-3
- Asynchronous Machine
 - per unit system 7-29
- Asynchronous Machine block 7-26

B

- bidirectional power flow capability 4-38
- block diagrams
 - creating 1-5
- blocks
 - nonlinear 3-16
 - powerlib block library 1-6
- blocks in drivelib

- AC1. six-step inverter fed Induction Motor.
7-397
 - AC2. space vector PWM VSI 7-410
 - AC3. field oriented control induction motor
7-101
 - AC4. direct torque and flux control induction
motor 7-85
 - AC5. Self-Controlled Synchronous Motor
7-347
 - AC6. Permanent Magnet Synchronous Motor
7-290
 - DC1. two-quadrant single-phase rectifier
7-645
 - DC2. four quadrant single-phase rectifier
7-136
 - DC3. two-quadrant three-phase rectifier
7-661
 - DC4. four quadrant three-phase rectifier
7-153
 - DC5. one-quadrant chopper 7-252
 - DC6. two-quadrant chopper 7-629
 - DC7. four-quadrant chopper 7-120
 - mecanical shaft 7-213
 - mecanical speed reducer 7-424
 - Breaker block 7-44
 - build and simulate a system with
 - AC motor drive 4-48
 - DC motor drive 4-14
 - mechanical shaft block 4-68
 - speed reducer block 4-69
- C**
- case studies
 - mechanical Coupling of Two Motor Drives
4-71
 - robot manipulator 4-84
- winding machine 4-77
 - chopper-fed DC drive
 - four-quadrant. See DC7 7-120
 - one-quadrant. See DC5 7-252
 - two-quadrant. See DC6 7-629
 - circuit
 - building a simple 1-5
 - circuit breaker 7-44
 - commands
 - power_analyze 8-3
 - power_init 8-11
 - power_statespace 8-33
 - connecting blocks 1-10
 - Connection Port block 7-49
 - control
 - close loop with slip speed compensation 4-44
 - direct torque (DTC) 4-46
 - flux oriented 4-44
 - hysteresis modulation 4-38
 - open loop Volts/Hertz 4-43
 - pulse width modulation (PWM) 4-38
 - schematic in user interface 4-28
 - set point 4-22
 - slip compensation 4-44
 - space vector modulation technique 4-40
 - Control System Toolbox 1-21
 - control systems
 - analyzing with the Control System Toolbox
1-21
 - speed control system 7-36
 - Controlled Current Source block 7-50
 - Controlled Voltage Source block 7-53
 - Current Measurement block 7-57
- D**
- DC Machine block 7-59

- DC Voltage Source block 7-67
- DC1
 - block description 7-645
 - block inputs and outputs 7-131, 7-149, 7-166, 7-263, 7-640, 7-657, 7-673
 - example 7-658
 - model specifications 7-658
- DC1 parameters
 - bridge firing unit 7-656
 - converter 7-652
 - current controller 7-655
 - DC bus and excitation circuit 7-652
 - DC machine 7-651
 - speed controller 7-654
- DC2
 - block description 7-136
 - block inputs and outputs 7-149
 - example 7-150
 - model specifications 7-150
- DC2 parameters
 - bridge firing unit 7-148
 - converter 7-143
 - current controller 7-147
 - DC bus and excitation circuit 7-143
 - DC machine 7-142
 - speed controller 7-146
- DC3
 - block description 7-661
 - example 7-674
 - model specifications 7-674
- DC3 parameters
 - bridge firing unit 7-672
 - converter 7-668
 - current controller 7-671
 - DC bus and excitation circuit 7-668
 - DC machine 7-667
 - speed controller 7-670
- DC4
 - block description 7-153
 - example 7-167
 - model specifications 7-167
- DC4 parameters
 - bridge firing unit 7-165
 - converter 7-160
 - current controller 7-164
 - DC bus and excitation circuit 7-160
 - DC machine 7-159
 - speed controller 7-163
- DC5
 - block description 7-252
 - block inputs and outputs 7-263
 - example 7-264
 - model specifications 7-264
- DC5 parameters
 - converter 7-259
 - current controller 7-262
 - DC machine 7-258
 - smoothing inductance and excitation circuit 7-259
 - speed controller 7-260
- DC6
 - block description 7-629
 - example 7-641
 - model specifications 7-641
- DC6 parameters
 - converter 7-636
 - current controller 7-639
 - DC machine 7-635
 - smoothing inductance and excitation circuit 7-636
 - speed controller 7-637
- DC7
 - block description 7-120
 - block inputs and outputs 7-131

- example 7-132
- model specifications 7-132
- DC7 parameters
 - converter 7-127
 - current controller 7-130
 - DC machine 7-126
 - smoothing inductance and excitation circuit 7-127
 - speed controller 7-128
- Demos model library 7-3
- Diode block 7-69
- direct torque control (DTC) 4-46
- Discrete System block 7-74
- display signals 1-9
- distributed parameter line
 - propagation speed 1-22
- Distributed Parameter Line block 7-75
- Distributed Resources (DR) block library 7-3
- dq0_to_abc Transformation block 7-83
- dynamic braking 4-38

E

- electric drive
 - applications 4-4
 - components 4-5
 - controller 4-6
 - converter 4-6
 - definition 4-4
 - motor 4-5
 - topology 4-5
- Electric Drives block library 7-2
- electrical circuits 1-1
- Electrical Sources block library 7-2
- Elements block library 7-2
- examples
 - buck converter 7-180

- distributed parameter line 7-79
- modulated current source 7-51
- permanent magnet synchronous machine 7-282
- PWM inverter 7-36
- surge arresters in series-compensated network 7-476
- synchronous machine in motoring mode 7-515
- zero-current-quasi-resonant switch converter 7-222
- Excitation System block 7-98
- Extras block library 7-3

F

- FACTS (flexible AC transmission systems) 5-1
- fixed-step simulation environment 4-57
- Flexible AC Transmission Systems (FACTS) block library 7-2
- Fourier block 7-116
- frequency analysis 7-270

G

- Generic Power System Stabilizer block 7-171
- Ground block 7-175
- GTO block 7-176

H

- HTG (hydraulic turbine and governor) 6-3
- HVDC (high voltage direct current) 5-39
- Hydraulic Turbine and Governor block 7-183
- hysteresis modulation 4-38

I

- Ideal Switch block 7-189

IGBT block 7-194
Impedance Measurement block 7-205
induction motor drive
 DTC control. See AC4 7-85
 field oriented control. See AC3 7-101
 six-step VSI. See AC1 7-397
 space vector PWM. See AC2 7-410
interconnections
 between electric and Simulink blocks 1-5
interface
 between Simulink and SimPowerSystems
 1-10

L

library
 opening 4-16
linear and nonlinear elements 1-5
Linear Transformer block 7-207
lines
 connection lines 1-12
 signal lines 1-12
load
 bidirectional load at the motor shaft 4-71

M

Machine Measurement Demux block 7-212
Machines block library 7-2
measurements
 current 7-57
 voltage 7-702
Measurements block library 7-2
mechanical coupling blocks
 driving shaft. See shaft 7-213
 speed reducer. See speed reducer 7-424
mechanical Coupling of Two Motor Drives

 speed regulated motor 4-73
 system description 4-71
 torque regulated motor 4-74
mechanical load
 connecting to a DC model 4-19
 connecting to an AC model 4-51
models
 limitations with nonlinear 3-16
 nonlinear model library 3-16
MOSFET block 7-219
Multiband Power System Stabilizer block 7-224
Multimeter block 7-231
multi-quadrant operation 4-7
Multi-Winding Transformer block 7-237
Mutual Inductance block 7-245

N

Neutral block 7-250

P

Parallel RLC Branch block 7-267
Parallel RLC Load block 7-272
parameters
 default regulation 4-29
 how to change a value 4-31
 initially loaded 4-26
 load procedure 4-26
 low and high power sets 4-26
PCC (point of common coupling) 5-61
per unit system 1-9
Permanent Magnet Synchronous Machine block
 7-275
PI section line
 frequency response 1-22
PI Section Line block 7-286

PLL (phase locked loop) 5-67

ports

 Simulink ports 1-12

 terminal ports 1-12

Power Electronics block library 7-2

power system 1-5

power_analyze command 8-3

power_init command 8-11

power_statespace command 8-33

Powergui block 7-304

powerlib library 1-6

PSS (power system stabilizer) 6-2

PST (phase shifting transformer) 6-13

pulse width modulation (PWM) technique 4-38

PWM Generator block 7-325

PWM inverter 7-36

Q

quadrants

 operating region 4-7

 representation 4-7

R

rectifier DC drive

 four-quadrant single phase. See DC2 7-136

 four-quadrant three-phase. See DC4 7-153

 two-quadrant single phase. See DC1 7-645

 two-quadrant three-phase. See DC3 7-661

regenerative braking 4-14

RMS block 7-332

robot

 case study 4-84

 position control systems 4-85

 tracking Performance of drive 4-90

S

Saturable Transformer block 7-335

saturable transformer model 5-6

Series RLC Branch block 7-365

Series RLC Load block 7-370

series-compensated transmission network 5-2

set point input to a drive 4-53

Shaft

 block description 7-213

 block inputs and outputs 7-216

 example 7-216

 model specifications 7-216

 parameters 7-215

Simplified Synchronous Machine block 7-374

simulation

 speed 3-19

sinusoidal source 1-7

snubber circuits

 in Diode block 7-69

 in GTO block 7-176

Speed Reducer

 block description 7-424

 block inputs and outputs 7-428

 example 7-429

 model specifications 7-428

STATCOM (static synchronous compensator) 5-29

state variable

 names 1-27

state-space model

 obtaining state-space matrices 8-8

Static Var Compensator block 7-452

Steam Turbine and Governor block 7-463

Surge Arrester block 7-473

SVC (static var compensator) 5-20

Synchronized 12-Pulse Generator block 7-494

Synchronized 6-Pulse Generator block 7-486

synchronous machine

- with regulators 4-95
- Synchronous Machine block 7-501
- Synchronous Motor Drive
 - permanent magnet. See AC6 7-290
 - self-controlled. See AC5 7-347
- systems
 - six-degrees-of-freedom robot manipulator
 - 4-84
 - two motor drives mechanically coupled together
 - 4-71
 - winding machine 4-77

T

- TCR (thyristor-controlled reactor) 5-20
- TCS (thyristor-switched capacitor) 5-20
- Three-Level Bridge block 7-517
- Three-Phase Dynamic Load block 7-531
- Three-Phase Fault block 7-536
- Three-Phase Harmonic Filter block 7-541
- Three-Phase Mutual Inductance Z1-Z0 block
 - 7-554
- Three-Phase Parallel RLC Branch block 7-574
- Three-Phase Parallel RLC Load block 7-576
- Three-Phase PI Section Line block 7-579
- Three-Phase Programmable Voltage Source block
 - 7-582
- Three-Phase Sequence Analyzer block 7-586
- Three-Phase Series RLC Branch block 7-590
- Three-Phase Series RLC Load block 7-592
- Three-Phase Source block 7-595
- Three-Phase Transformer (Three Windings) block
 - 7-607
- Three-Phase Transformer (Two Windings) block
 - 7-600
- Three-Phase Transformer 12 Terminals block
 - 7-598

- Three-Phase V-I Measurement block 7-613
- Thyristor block 7-617
- Timer block 7-625
- Total Harmonic Distortion block 7-627
- transformers
 - linear 7-207
 - three-phase 5-6
- transmission lines
 - propagation time 1-22

U

- Universal Bridge block 7-677
- UPFC (unified power flow controller) 6-8
- user interface
 - display of parameters 4-26
 - drive library 4-26
 - load button 4-27
 - schematic button 4-28
 - tabs 4-26

V

- VDCOL (voltage dependent current order limiter)
 - 5-46
- visualizing internal signals of
 - AC drive block 4-54
 - DC drive block 4-22
- void marker 7-410
- Voltage Measurement block 7-702
- voltage source
 - connection to a DC drive block 4-16
 - connection to an AC drive block 4-50
- VSC (voltage sourced converter) 5-61
- VSI inverters in drive 4-38

W

winders

control 4-80

description 4-77

simulation results 4-81

Z

Zigzag Phase-Shifting Transformer block 7-744